

TAPER DETAIL FOR PROPOSED BITUMINOUS SHOULDERS

(TRANSITION WIDTH FOR PROPOSED BITUMINOUS SHOULDERS FROM 1'-0" TO 3'-0" WITHIN 10'-0")

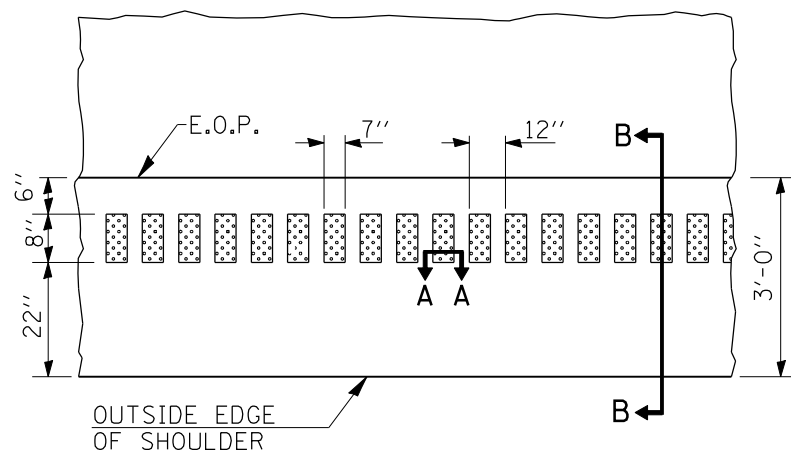

PLAN VIEW

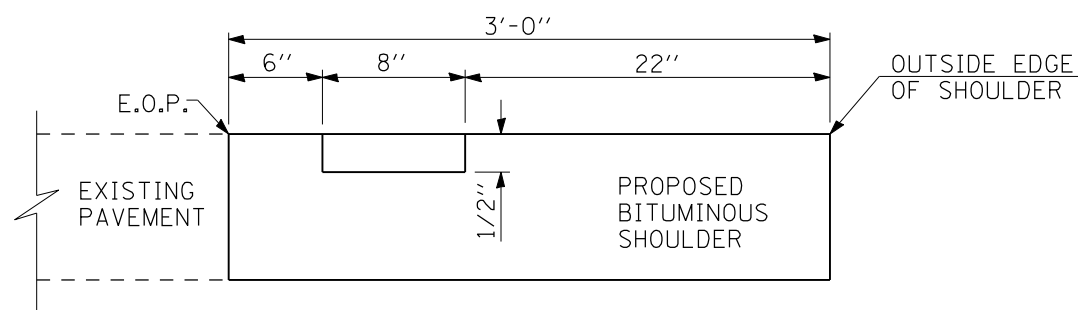

SECTION B-B

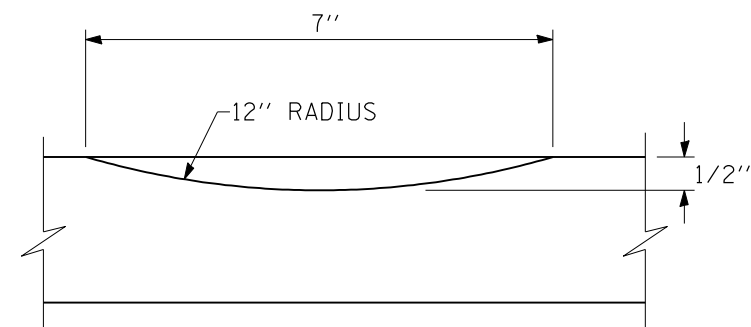

SECTION A-A

*-D-6 RUMBLE STRIPS 2008-01

FILE NAME = c:\projects\d610607\shpdf.dgn	USER NAME = laughtin1	DESIGNED - RTS	REVISED - DEC. 27, 2007
		DRAWN - RTS	REVISED -
		CHECKED - MEB	REVISED -
		DATE - DEC. 27, 2007	REVISED -

**STATE OF ILLINOIS
DEPARTMENT OF TRANSPORTATION**

BITUMINOUS SHOULDER /RUMBLE STRIP DETAILS

SCALE: NO SCALE SHEET NO. 1 OF 1 SHEETS STA. TO STA.

FAP RTE.	SECTION	COUNTY	TOTAL SHEETS	SHEET NO.
1613	*	SANGAMON	20	15
CONTRACT NO. 72B29				
FED. ROAD DIST. NO. ILLINOIS FED. AID PROJECT				