

- NOTES:
- ALL STEEL ANGLES AND PLATES TO BE GALVANIZED AFTER FABRICATION.
 - ALL RESTRICTOR PLATES, ANGLES AND HARDWARE TO BE INCLUDED IN THE COST OF THE MANHOLE.
 - BASIS OF PAYMENT: "MANHOLES, TYPE A, 6 FT. (1.8 m)-DIAMETER, TYPE 1 FRAME, CLOSED LID, RESTRICTOR PLATE" EACH

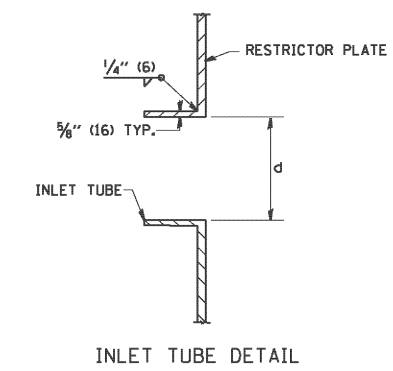

STATION	MANHOLE DIAMETER	FRAME AND GRATE	RESTRICTOR TYPE	INSIDE RESTRICTOR TYPE DIAMETER in. (mm) (d)	INVERT OF RESTRICTOR TYPE	ELEVATION OF TOP OF PLATE OVERFLOW
406+38.82 LT	6'	2-T-1-OL	SHARP EDGED	8	626.69	632.40
288+04.34 LT	6'	2-T-1-OL	SHARP EDGED	12.6	627.31	631.58
278+73.45 LT	6'	2-T-1-OL	SHARP EDGED	7.3	625.71	628.80
264+90.66 LT	8'	2-T-1-OL	SHARP EDGED	45.5	621.22	624.80

△ = STRUCTURE ID

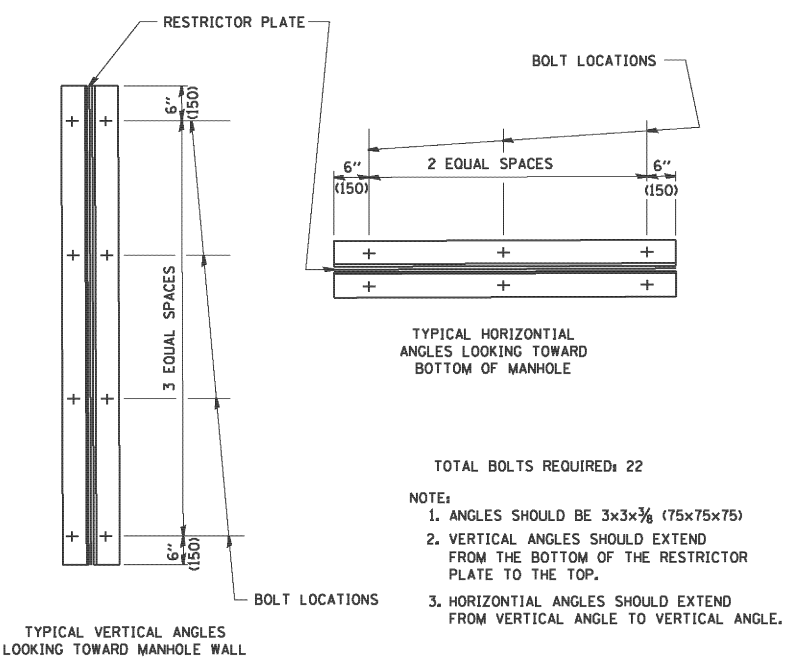

RESTRICTOR TYPE					
1	2	3	4	5	6
RE-ENTRANT TUBE	SHARP EDGED	SQUARE EDGED	RE-ENTRANT TUBE	SQUARE EDGED	ROUNDED
LENGTH: 1/2 TO 1 DIA.		STREAM CLEARS SIDES	LENGTH: 2-1/2 DIA.	LENGTH: 2-1/2 DIA.	
C=.52	C=.61	C=.61	C=.73	C=.82	C=.98

VALUES OF "C" FOR CIRCULAR AND SQUARE ORIFICES

ALL DIMENSIONS ARE IN INCHES (MILLIMETERS) UNLESS OTHERWISE SHOWN.

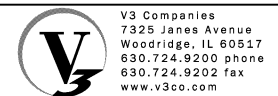

USER NAME = hshh	DESIGNED - DSS	REVISED -
PLOT SCALE = 1:8000' / 1"	DRAWN - DRP	REVISED -
PLOT DATE = 8/21/2013	CHECKED - VJD	REVISED -
	DATE - 08/14/2013	REVISED -

STATE OF ILLINOIS
DEPARTMENT OF TRANSPORTATION

MANHOLE WITH
RESTRICTOR PLATE

SCALE: N/A SHEET NO. 1 OF 1 SHEETS

F.A.P. RTE.	SECTION	COUNTY	TOTAL SHEETS	SHEET NO.
353	11-Y-A	COOK	354	290
CONTRACT NO. 60R19				
ILLINOIS FED. AID PROJECT				