

**SECURITY GATE/FENCING PLAN DETAIL AT EAST GATE  
WEST SECURITY GATE/FENCING OPPOSITE HAND SIMILAR**

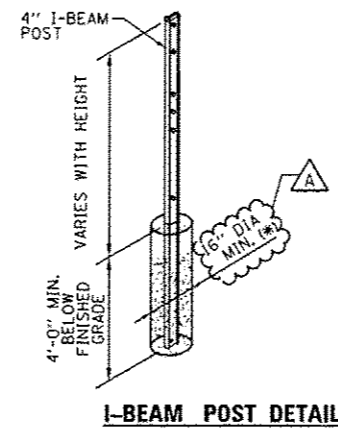

**I-BEAM POST DETAIL**

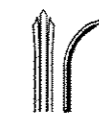

**PALE DETAIL**

- NOTES:**
1. THE ASTERISK (\*) INDICATES DIMENSIONS TO BE DETERMINED BY GATE MANUFACTURER AND CONTRACTOR'S ILLINOIS LICENSED STRUCTURAL ENGINEER.
  2. REINFORCE GATE FOUNDATION FOOTINGS WITH MINIMUM #5 @ 12 EACH WAY, TOP, BOTTOM AND SIDES. ALL REINFORCING BARS SHALL BE EPOXY COATED.
  3. EXISTING WATER MAIN TO REMAIN. VERIFY LOCATION IN FIELD TO ALLOW FOR MINIMUM 12" OF SOIL BETWEEN PIPE AND GATE OR FENCE FOUNDATIONS.
  4. COORDINATE POST AND FOUNDATION LOCATIONS WITH EXISTING AND PROPOSED UTILITIES. LAYOUT SHALL BE ADJUSTED AS NECESSARY TO AVOID IMPACTS.

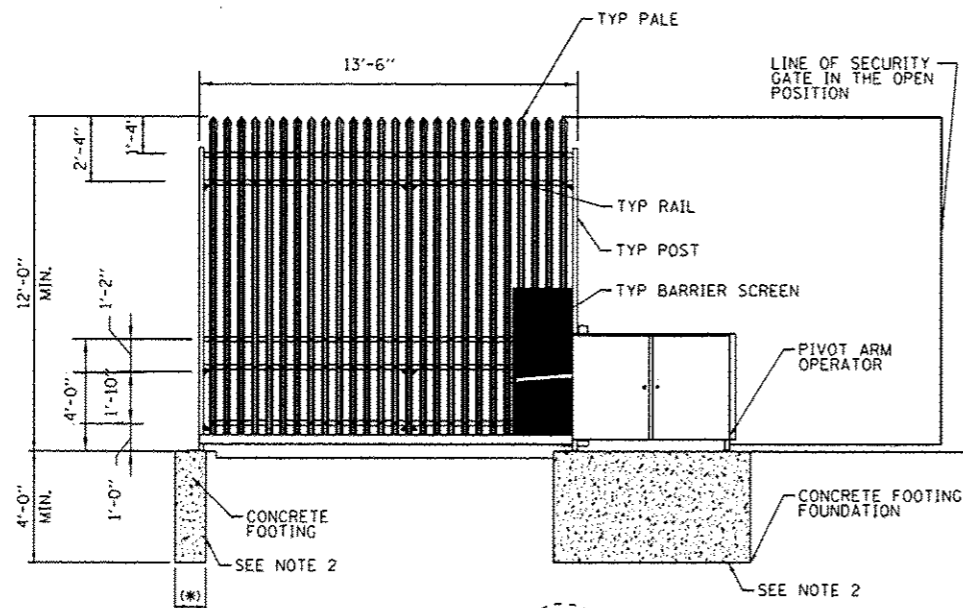

**SECURITY GATE ELEVATION  
NOTE: ADJACENT FENCING  
NOT SHOWN FOR CLARITY**

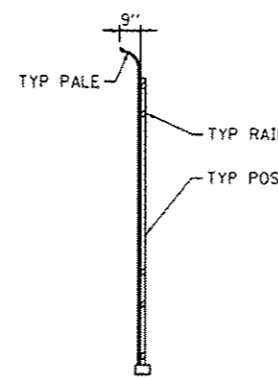

**SECURITY GATE SECTION**

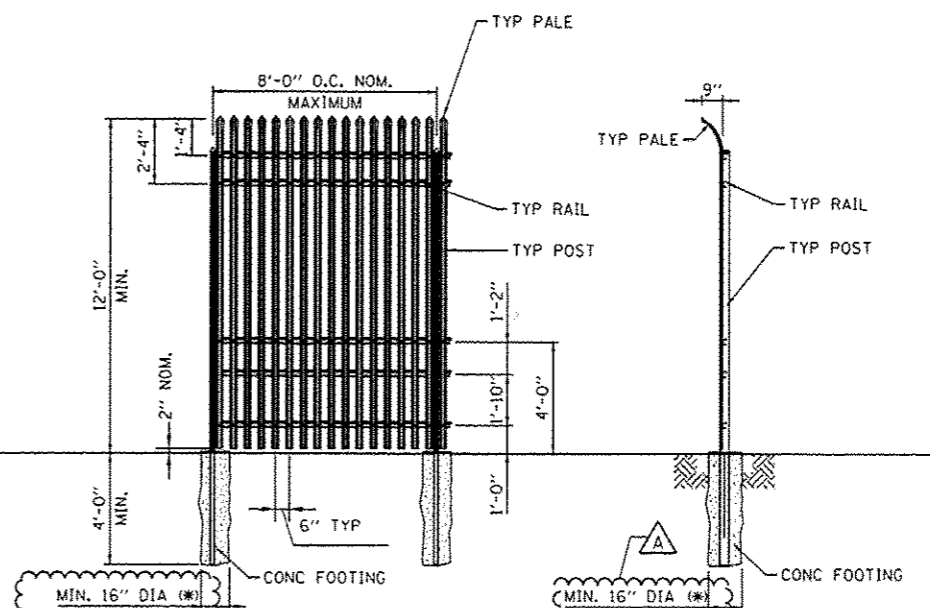

**SECURITY FENCE ELEVATION  
TYPICAL 8'-0" PANEL**

**TYPICAL SECURITY FENCE SECTION**

FILE PATH: \\p01\388803\p01\meson\line\local\p01\AECOM\001\Documents\01\60W71-Fence\01\60W71-Fence.dwg



60W71-Fence-02  
USER NAME: Chiu  
PLOT SCALE: 20.0000' / 1" =  
PLOT DATE: 4/4/2014

DESIGNED - JP  
DRAWN - MSC  
CHECKED - DBM  
DATE - 02/19/14

REVISED - A 04/03/2014  
REVISED -  
REVISED -  
REVISED -

**STATE OF ILLINOIS  
DEPARTMENT OF TRANSPORTATION**

**FENCE AND GATE DETAILS**

SCALE: NONE SHEET 1 OF 1 SHEETS STA. TO STA.

F.A.T. RTE.	SECTION	COUNTY	TOTAL SHEETS	SHEET NO.
90/94/290	2013-036R	COOK	256	236
CONTRACT NO. 60W71			ILLINOIS FED. AID PROJECT	