

SIGN TABLE

SIGN	DIMENSIONS
R10-3b	9" (228mm) X 12" (305mm)
R10-3d	9" (228mm) X 12" (305mm)
R10-3e	9" (228mm) X 15" (381mm)

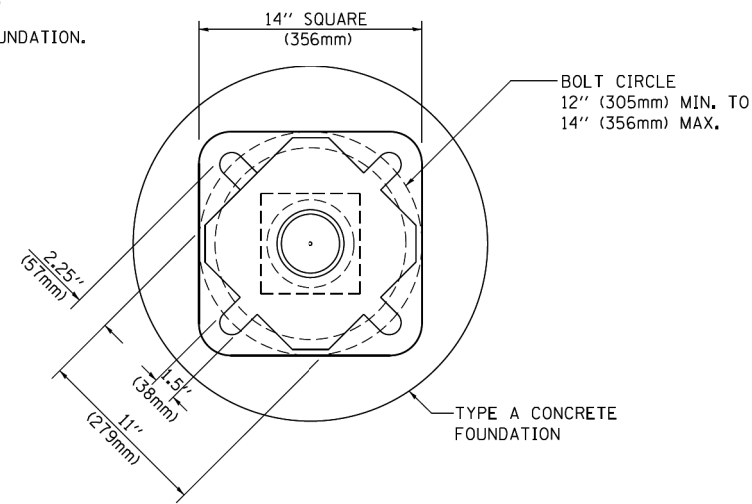

BOLT PATTERN

PEDESTRIAN PUSH BUTTON POST, TYPE A

FILE NAME =	USER NAME = footemj	DESIGNED - DAG	REVISED - DAG 1-1-14
ca:\pwork\pwork\footemj\00108315\ts05.dgn		DRAWN - GND	REVISED -
PLOT SCALE = 50.0000 / 1"		CHECKED - DAD	REVISED -
PLOT DATE = 1/13/2014		DATE - 10/1/2012	REVISED -

**STATE OF ILLINOIS
DEPARTMENT OF TRANSPORTATION**

DISTRICT ONE STANDARD TRAFFIC SIGNAL DESIGN DETAILS			
SCALE: NONE	SHEET NO. 7 OF 7 SHEETS	STA.	TO STA.

F.A.P. RTE.	SECTION	COUNTY	TOTAL SHEETS	SHEET NO.
344	2013-063TS	DUPAGE	68	19
TS-05			CONTRACT NO. 60X35	
FED. ROAD DIST. NO. 1 ILLINOIS FED. AID PROJECT				