

THE TRAFFIC SIGNAL CONTROL EQUIPMENT FOR THIS PROJECT SHALL BE "EAGLE" TO MATCH THE EXISTING ADJACENT SYSTEM.

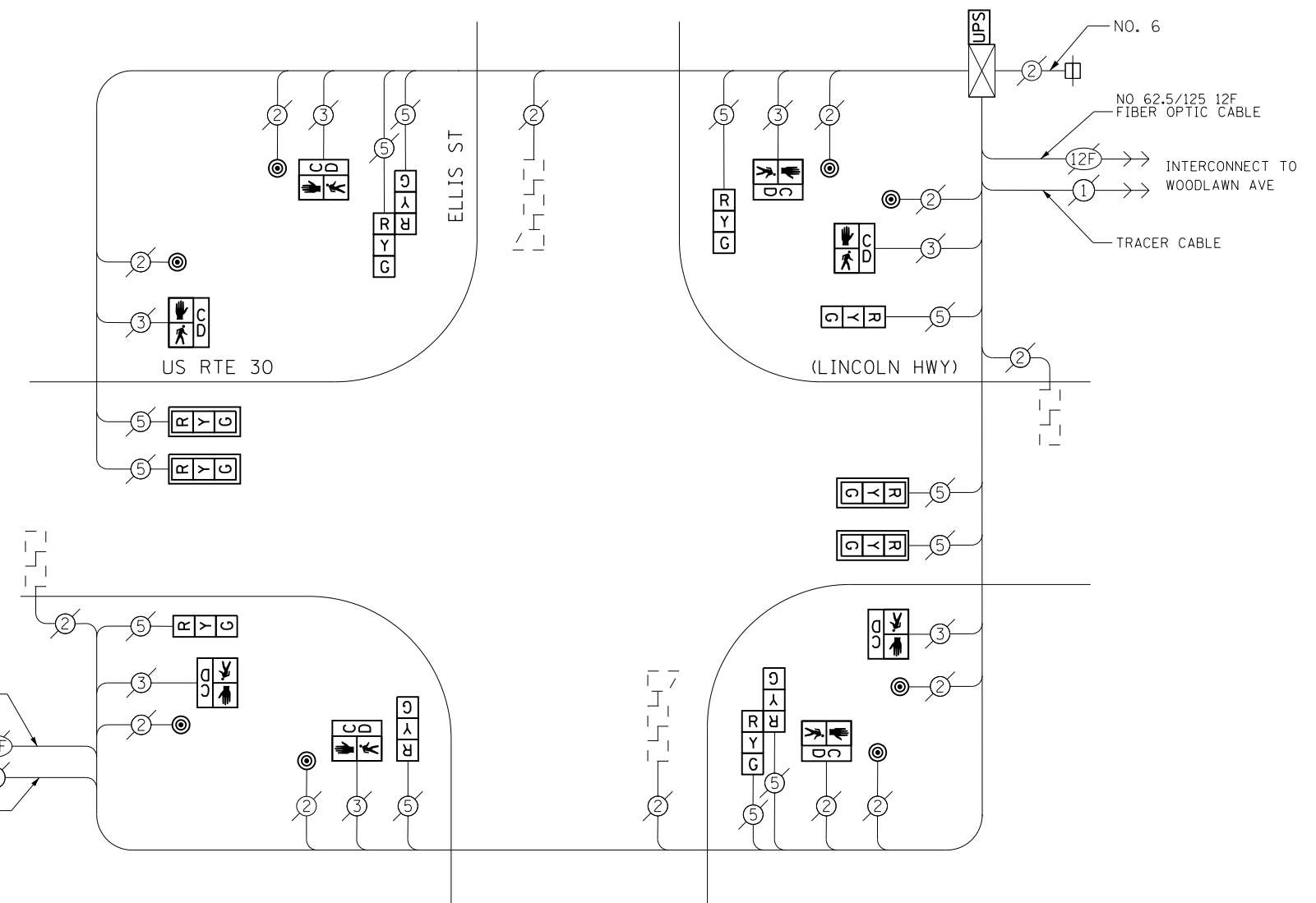

RETROFIT ALL EXISTING SIGNAL HEADS TO L.E.D.

CONTRACTOR SHALL REPLACE BROKEN MOUNTING BRACKETS AT ALL RETROFIT SIGNAL HEADS OR AS DIRECTED BY THE ENGINEER. THE COST OF THIS WORK SHALL BE INCLUDED IN THE CORRESPONDING SIGNAL HEAD, LED, RETROFIT PAY ITEM OF THE TYPE AND NUMBER OF SIGNAL HEADS, FACES, AND SECTIONS AS SPECIFIED IN THE PLANS.

SCHEDULE OF QUANTITIES

| Items | Unit | Quantity |
|---|------|----------|
| MAINTENANCE OF EXISTING TRAFFIC SIGNAL INSTALLATION | EACH | 1 |
| PEDESTRIAN SIGNAL HEAD, LED, 1-FACE, BRACKET MOUNTED WITH COUNTDOWN TIMER | EACH | 8 |
| PEDESTRIAN PUSH-BUTTON | EACH | 8 |
| MODIFY EXISTING CONTROLLER CABINET | EACH | 1 |
| REMOVE EXISTING TRAFFIC SIGNAL EQUIPMENT | EACH | 1 |
| UNINTERRUPTABLE POWER SUPPLY, SPECIAL | EACH | 1 |
| SIGNAL HEAD, LED, 1-FACE, 3-SECTION, BRACKET MOUNTED, RETROFIT | EACH | 4 |
| SIGNAL HEAD, LED, 1-FACE, 3-SECTION, MAST ARM MOUNTED, RETROFIT | EACH | 4 |
| SIGNAL HEAD, LED, 2-FACE, 3-SECTION, BRACKET MOUNTED, RETROFIT | EACH | 2 |

REMOVAL OF EXISTING TRAFFIC SIGNAL EQUIPMENT

THE FOLLOWING ITEMS SHALL BE REMOVED BY THE CONTRACTOR AND SHALL BE DISPOSED OF BY THEM OUTSIDE THE RIGHT-OF-WAY AT THEIR EXPENSE. THE SALVAGE VALUE OF THE REMOVED EQUIPMENT SHALL BE REFLECTED IN THE CONTRACT BID PRICE.

- 8 EACH PEDESTRIAN SIGNAL HEAD, 1-FACE
- 8 EACH PEDESTRIAN PUSH-BUTTON

| I. D. O. T. TRAFFIC SIGNAL INSTALLATION ELECTRICAL SERVICE REQUIREMENTS | | | | | |
|---|-----------|-----------------|-------------|------------|---------------|
| TYPE | NO. LAMPS | WATTAGE INCAND. | WATTAGE LED | %OPERATION | TOTAL WATTAGE |
| SIGNAL (RED) | 12 | - | 17 | 0.50 | 102.0 |
| (YELLOW) | 12 | - | 25 | 0.25 | 75.0 |
| (GREEN) | 12 | - | 15 | 0.25 | 45.0 |
| ARROW | - | - | 12 | 0.10 | - |
| PED. SIGNAL | 8 | - | 25 | 1.00 | 200.0 |
| CONTROLLER | 1 | 100 | - | 1.00 | 100.0 |
| ILLUM. SIGN | - | - | 25 | 0.50 | - |
| VIDEO SYSTEM | - | 150 | - | 1.00 | - |
| BATTERY BACKUP | 1 | 25 | - | 1.00 | 25.0 |
| LUMINAIRE | - | 250 | - | 0.50 | - |
| FLASHER | - | - | 25 | 0.50 | - |
| TOTAL = | | | | | 547.0 |

ENERGY COSTS- **BILLED TO: IDOT DISTRICT 1**
201 WEST CENTER COURT
SCHAUMBURG, IL 60196-1096

ENERGY SUPPLY- **CONTACT BRAD SHINABARGAR**
PHONE 708-325-2692
COMMONWEALTH EDISON