

LEGEND
 ○ → DUAL ENTRY PHASE
 ◇ OL OVERLAP
 ○ → PEDESTRIAN PHASE
 * NUMBER REFERS TO ASSOCIATED PHASE

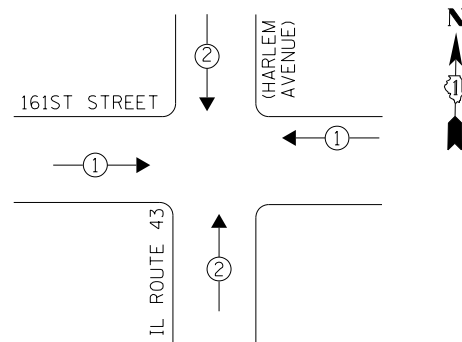

EXISTING EMERGENCY VEHICLE PREEMPTION SEQUENCE

EMERGENCY VEHICLE PREEMPTORS		
EMERGENCY VEHICLE PREEMPTOR	1	2
MOVEMENT	← →	↓ ↑

**I. D. O. T.
TRAFFIC SIGNAL INSTALLATION
ELECTRICAL SERVICE REQUIREMENTS**

TYPE	NO. LAMPS	WATTAGE INCAND.	WATTAGE LED	%OPERATION	TOTAL WATTAGE
SIGNAL (RED)	14	-	17	0.50	119.0
(YELLOW)	14	-	25	0.25	87.5
(GREEN)	14	-	15	0.25	52.5
ARROW	16	-	12	0.10	19.2
PED. SIGNAL	4	-	25	1.00	100.0
CONTROLLER	1	100	-	1.00	100.0
ILLUM. SIGN	-	-	84	0.05	-
VIDEO SYSTEM	-	150	-	1.00	-
BATTERY BACKUP	1	25	-	1.00	25.0
LUMINAIRE	-	-	-	-	-
FLASHER	-	-	25	0.50	-
TOTAL =					503.2

ENERGY COSTS- **BILLED TO: IDOT DISTRICT 1**
 201 WEST CENTER COURT
 SCHAUMBURG, IL 60196-1096

ENERGY SUPPLY- **CONTACT BRAD SHINABARGAR**
 PHONE 708-325-2692
 COMMONWEALTH EDISON

THE TRAFFIC SIGNAL CONTROL EQUIPMENT FOR THIS PROJECT SHALL BE "EAGLE" TO MATCH THE EXISTING ADJACENT SYSTEM.

SCHEDULE OF QUANTITIES

Items	Unit	Quantity
MAINTENANCE OF EXISTING TRAFFIC SIGNAL INSTALLATION	EACH	1
PEDESTRIAN SIGNAL HEAD, LED, 1-FACE, BRACKET MOUNTED WITH COUNTDOWN TIMER	EACH	2
PEDESTRIAN SIGNAL HEAD, LED, 2-FACE, BRACKET MOUNTED WITH COUNTDOWN TIMER	EACH	1
MODIFY EXISTING CONTROLLER CABINET	EACH	1
REMOVE EXISTING TRAFFIC SIGNAL EQUIPMENT	EACH	1
UNINTERRUPTABLE POWER SUPPLY, SPECIAL	EACH	1
SIGNAL HEAD, LED, 1-FACE, 3-SECTION, MAST ARM MOUNTED, RETROFIT	EACH	6
SIGNAL HEAD, LED, 1-FACE, 5-SECTION, MAST ARM MOUNTED, RETROFIT	EACH	4
SIGNAL HEAD, LED, 1-FACE, 5-SECTION, BRACKET MOUNTED, RETROFIT	EACH	4
PEDESTRIAN PUSH-BUTTON, NON-LATCHING	EACH	3

RETROFIT ALL EXISTING SIGNAL HEADS TO L.E.D.

CONTRACTOR SHALL REPLACE BROKEN MOUNTING BRACKETS AT ALL RETROFIT SIGNAL HEADS OR AS DIRECTED BY THE ENGINEER. THE COST OF THIS WORK SHALL BE INCLUDED IN THE CORRESPONDING SIGNAL HEAD, LED, RETROFIT PAY ITEM OF THE TYPE AND NUMBER OF SIGNAL HEADS, FACES, AND SECTIONS AS SPECIFIED IN THE PLANS.

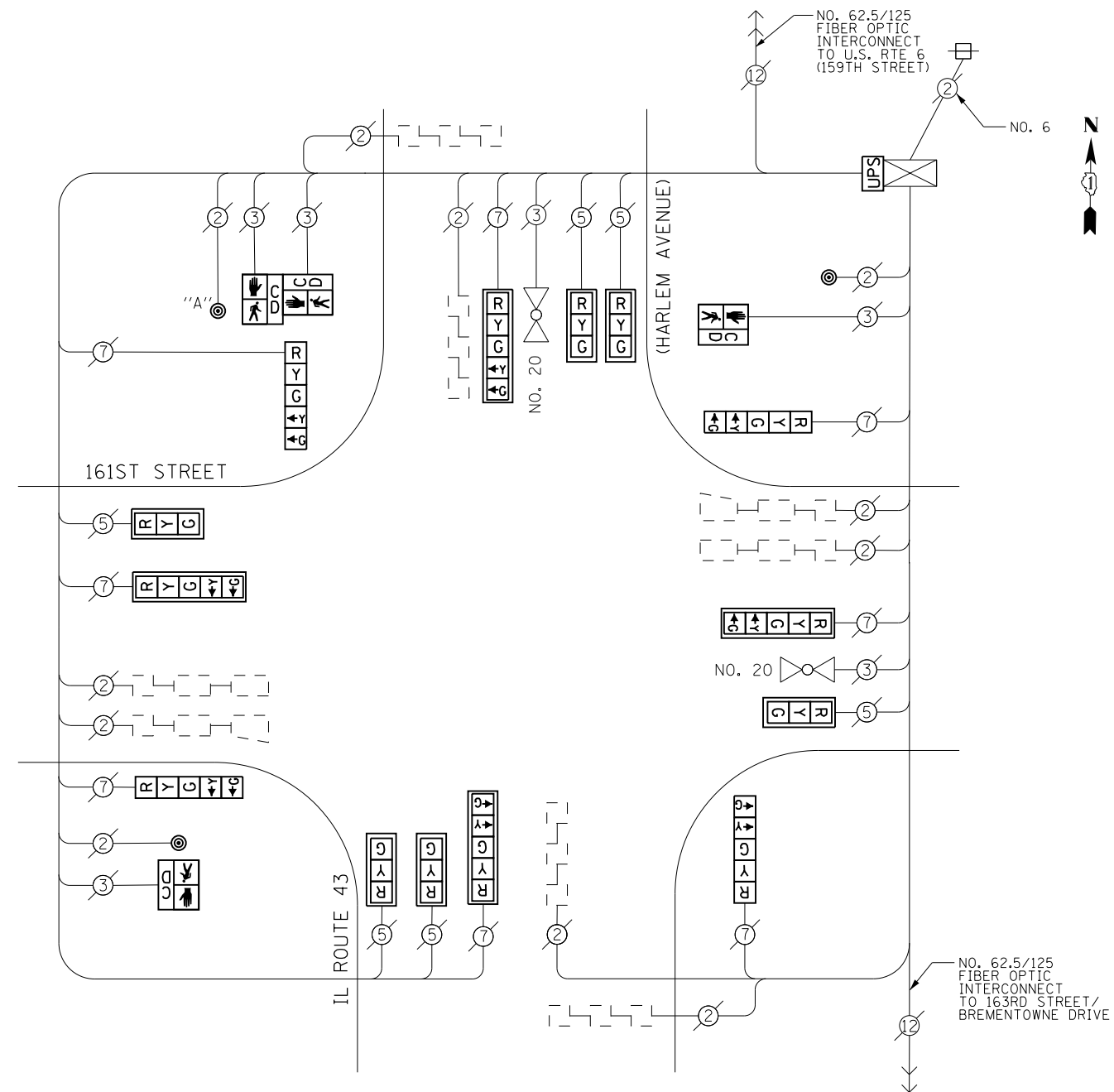

CABLE PLAN

PUSHBUTTON NOTES:

PUSHBUTTON "A" SHALL PLACE A CALL IN PHASES 6 AND 8

REMOVAL OF EXISTING TRAFFIC SIGNAL EQUIPMENT

THE FOLLOWING ITEMS SHALL BE REMOVED BY THE CONTRACTOR AND SHALL BE DISPOSED OF BY THEM OUTSIDE THE RIGHT-OF-WAY AT THEIR EXPENSE. THE SALVAGE VALUE OF THE REMOVED EQUIPMENT SHALL BE REFLECTED IN THE CONTRACT BID PRICE.

- 2 EACH PEDESTRIAN SIGNAL HEAD, 1-FACE
- 1 EACH PEDESTRIAN SIGNAL HEAD, 2-FACE
- 3 EACH PEDESTRIAN PUSH-BUTTON

TS 11325
TINLEY PARK

FILE NAME = D:\60X65-shr-TS11325.dgn	USER NAME = SE3	DESIGNED - PHL	REVISED -
Default	PLOT SCALE = 48.0000' / in.	DRAWN - PHL	REVISED -
	PLOT DATE = 2/4/2014	CHECKED - BKS	REVISED -
		DATE - \$SUBDATE	REVISED -

**STATE OF ILLINOIS
DEPARTMENT OF TRANSPORTATION**

**IL ROUTE 43 (HARLEM AVENUE) AT 161ST STREET - CABLE PLAN
SCHEDULE OF QUANTITIES, PHASE DESIG. DIAGRAM & EVP SEQUENCE**

SCALE: SHEET OF SHEETS STA. TO STA.

F.A. RTE.	SECTION	COUNTY	TOTAL SHEETS	SHEET NO.
	2013-076TS	COOK	65	60
CONTRACT NO. 60X65				
ILLINOIS FED. AID PROJECT				