

PLAN

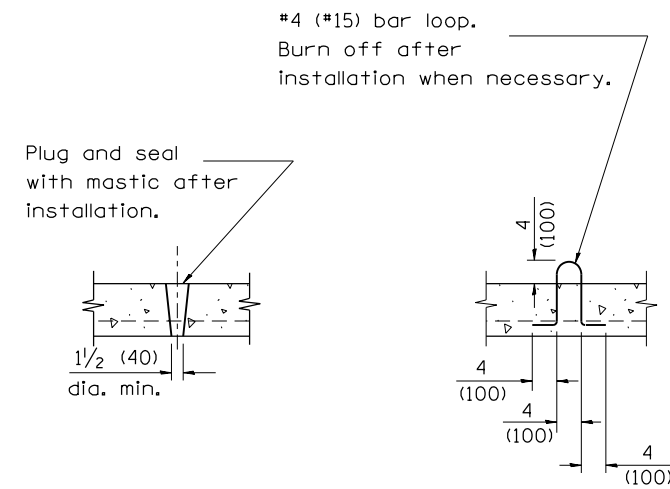

LIFTING HOLE OR LIFTING LOOP
TYPICAL

(3 required per slab)

TABLE

D	T	D _o (min.)	t	Reinforcement "As" W.W.F. each direction	Bar size	No. 15 (No. 4) Bar C	
						Length	Radius
4' (1.2m)	5 (125)	4'-10" (1.5m)	6 (150)	0.70 sq. inch/lin. ft. (1480mm ² /m)	No. 15 (No. 5)	1.35m (4'-6")	660 (26)
5' (1.5m)	6 (150)	6'-0" (1.8m)	8 (200)	0.70 sq. inch/lin. ft. (1480mm ² /m)	No. 15 (No. 5)	1.5m (5'-0")	810 (32)
6' (1.8m)	7 3/4 (195)	7'-3 1/2" (2.2m)	8 (200)	0.88 sq. inch/lin. ft. (1860mm ² /m)	No. 20 (No. 6)	1.8m (6'-0")	965 (38)
8' (2.4m)	9 (225)	9'-6" (2.9m)	10 (250)	0.88 sq. inch/lin. ft. (1860mm ² /m)	No. 20 (No. 6)	2.3m (7'-6")	1.27m (4'-2")

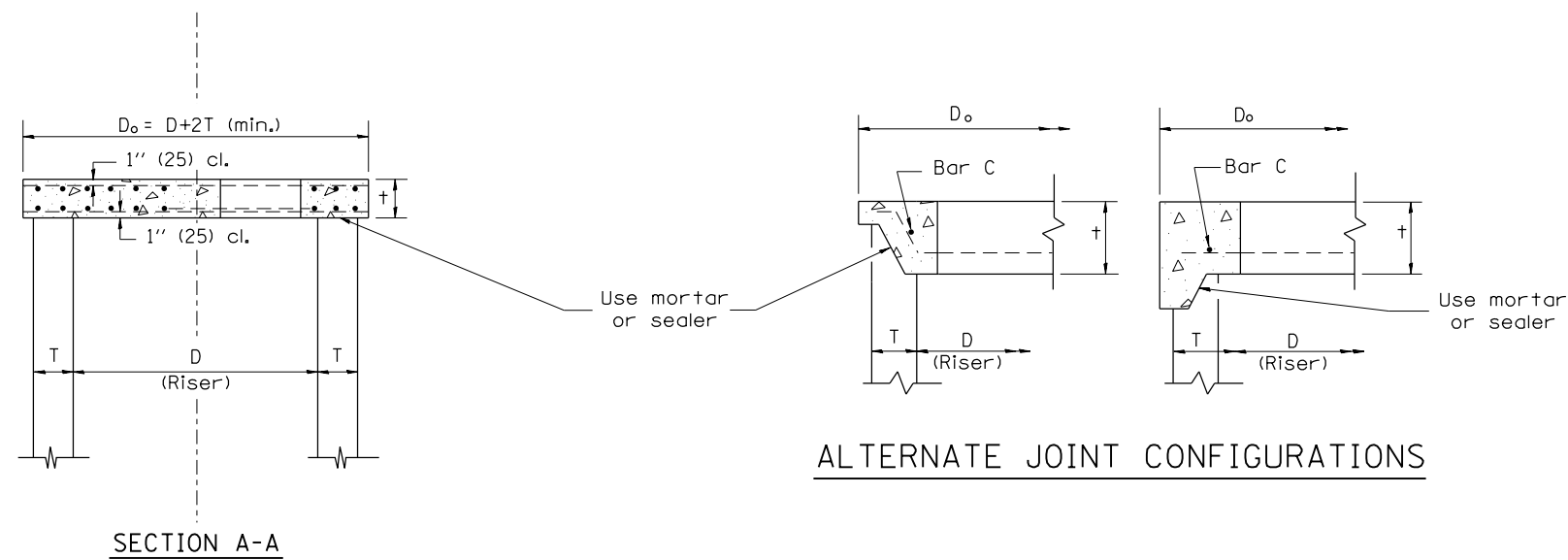
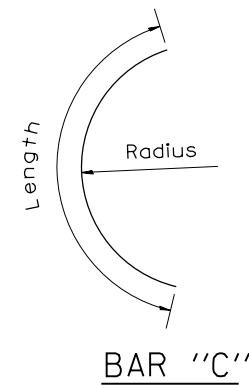

GENERAL NOTES

- The precast reinforced concrete flat slab top shall be used with INLET-MANHOLE, TYPE G-1 and INLET-MANHOLE, TYPE G-1, SPECIAL.
- Joint configuration and dimensions of flat slab top shall match and fit the riser joint detail.
- Lifting devices shall be approved by the Engineer.

All dimensions are in inches (millimeters) unless otherwise noted.