

PROPOSED TYPICAL SECTION
STATION 531+79.12 TO STATION 535+13.94
 (ALL SLOPES AND DIMENSIONS AT RIGHT ANGLES TO BASELINE)

PAVED SHOULDER REMOVAL

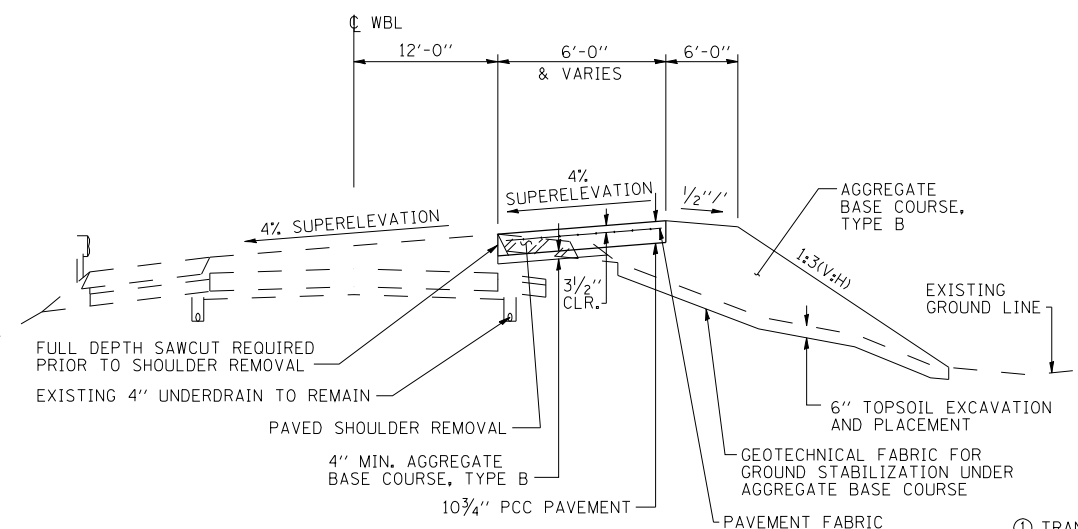

PROPOSED TYPICAL SECTION
STATION 529+05.11 TO STATION 531+79.12

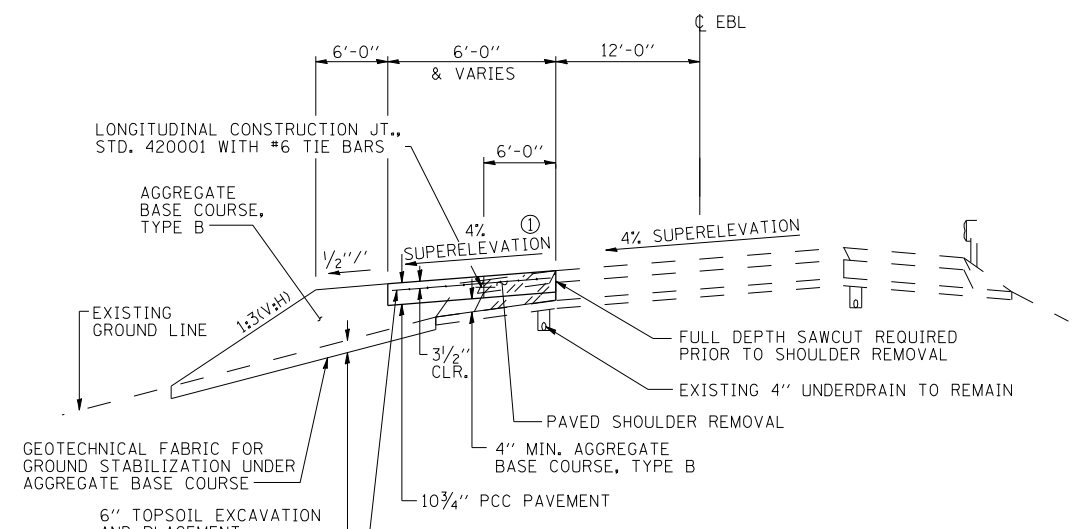

PROPOSED TYPICAL SECTION
STATION 535+13.94 TO STATION 537+79.78

① TRANSITION TO EXISTING SHOULDER SLOPE IN 10 FEET

PRINT DRIVER = L:\05-EB\0411...
 SCALE: NONE
 FILE NAME = D:\2014\140804.dwg



USER NAME = has	DESIGNED - ELH	REVISED -
ESCA PROJECT NO. 1000.05	DRAWN - HAS	REVISED -
PLOT SCALE = 0:2' = 1" / IN.	CHECKED - RDP	REVISED -
PLOT DATE = 1/29/2014 1:35:38 PM	DATE - 04/13	REVISED -

STATE OF ILLINOIS
DEPARTMENT OF TRANSPORTATION

WEST MEDIAN CROSSOVER - WB
PROPOSED TYPICAL SECTIONS

SCALE: NONE SHEET NO. 1 OF 1 SHEETS STA. TO STA.

F.A.I. RTE.	SECTION	COUNTY	TOTAL SHEETS	SHEET NO.
70	(26-3B-1, 3B-1(3))BR	FAYETTE	277	19
CONTRACT NO. 74175				
FED. ROAD DIST. NO. ILLINOIS FED. AID PROJECT				