

TYPICAL SECTION
 STA. 148+38 TO STA. 287+93
 STA. 289+73 TO STA. 438+00
 STA. 445+20 TO STA. 574+59

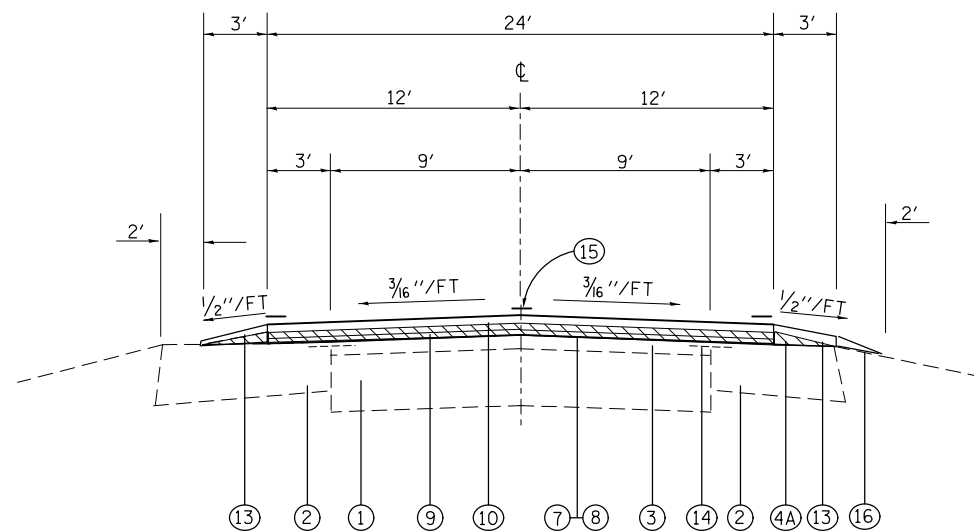

TYPICAL SECTION
 STA. 287+93 TO STA. 288+43
 STA. 289+23 TO STA. 289+73

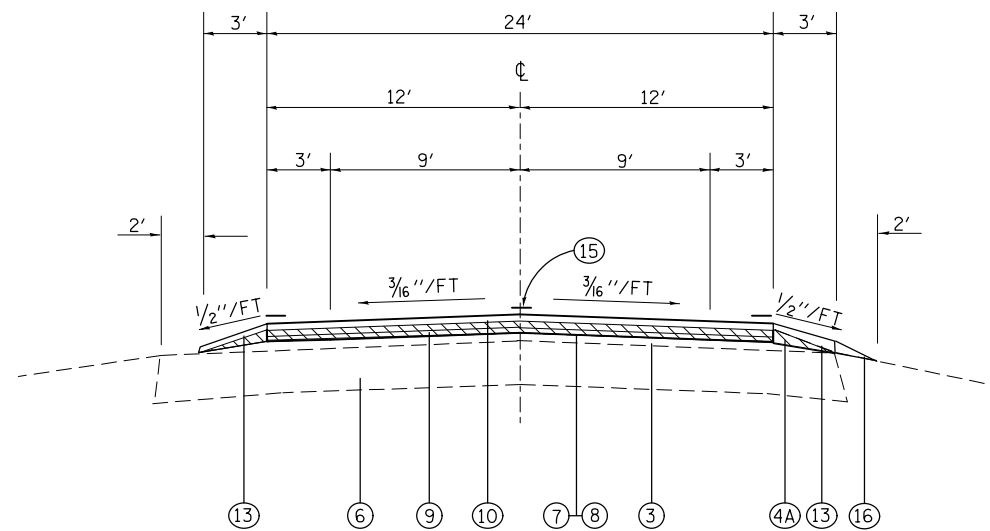

TYPICAL SECTION
 STA. 288+43 TO STA. 289+23

EARTH FILL, IF NEEDED, SHALL BE INCLUDED IN THE COST OF THE OTHER CONTRACT PAY ITEMS.

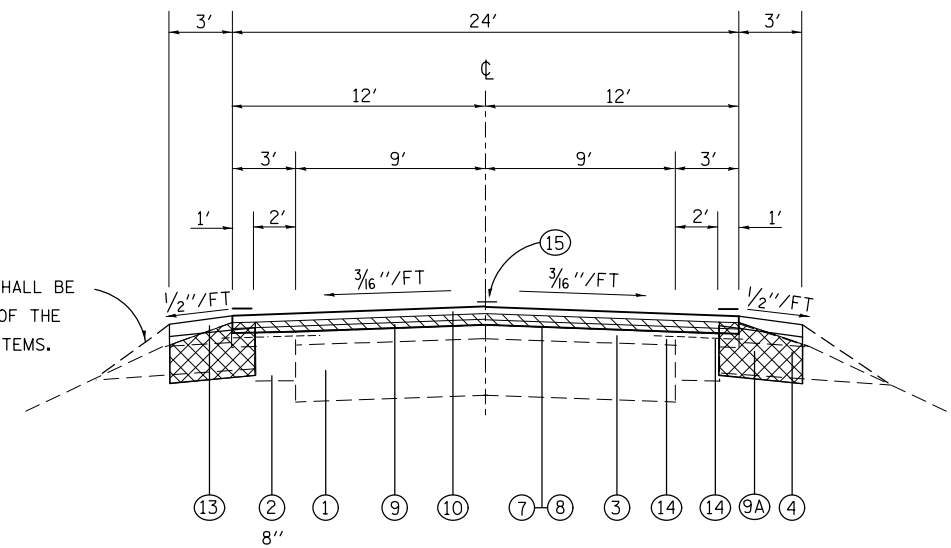

TYPICAL SECTION
ADJACENT TO SN 095-0066
 STA. 438+00 TO STA. 440+87.4
 STA. 443+52 TO STA. 445+20

NOTES: STRUCTURE AND APPROACH PAVEMENTS ARE OMITTED FROM RESURFACING; HOWEVER, THE PROPOSED HMA SHOULDERS 8" SHALL CONTINUE TO WHERE THE PCC BRIDGE APPROACH SHOULDER BEGINS. CARE SHALL BE TAKEN NOT TO DAMAGE THE EXISTING GUARDRAIL.

THE INNER ONE FOOT OF WIDENING ADJACENT TO THE PAVEMENT SHALL BE RESURFACED WITH THE PAVEMENT. THE OUTER THREE FEET SHALL BE SURFACED AS HMA SHOULDERS.

LEGEND

- ① EXISTING 9"-6"-9" PCC PAVEMENT
- ② EXISTING HMA BASE COURSE WIDENING, 9"
- ③ EXISTING HMA RESURFACING
- ④ EXISTING AGGREGATE SHOULDERS, TYPE B
- ④A EXISTING HMA SHOULDER
- ⑤ EXISTING CURB & GUTTER
- ⑥ EXISTING PCC BASE COURSE 9"
- ⑦ PROPOSED BITUMINOUS MATERIALS (PRIME COAT)
- ⑧ PROPOSED AGGREGATE (PRIME COAT)
- ⑨ PROPOSED LEVELING BINDER (MACHINE METHOD), IL-9.5FG, N70 - 3/4"
- ⑨A PROPOSED HMA BASE COURSE WIDENING, 8"
- ⑩ PROPOSED HMA SURFACE COURSE, MIX "C", N70 - 1 1/2"
- ⑫ PROPOSED HMA SHOULDERS, 8"
- ⑬ PROPOSED HMA SHOULDERS, VARIES 2 1/4" AT EOP TO 1" AT OUTER EDGE
- ⑭ PROPOSED STRIP REFLECTIVE CRACK CONTROL TREATMENT
- ⑮ PROPOSED PAVEMENT MARKING
- ⑯ PROPOSED AGGREGATE WEDGE SHOULDER, TYPE B



HMA SURFACE REMOVAL, 1/2"



EARTH EXCAVATION: THIS PAY ITEM SHALL INCLUDE THE REMOVAL OF EXISTING HMA, PCC, AND AGGREGATE FROM PRIOR RESURFACING PROJECTS.

FILE NAME =	USER NAME = mlcsmr	DESIGNED -	REVISED -
et:\pw\work\p\dot\mlcsmr\d0345201\d876961-sht-pln.dgn		DRAWN -	REVISED -
	PLOT SCALE = 100.0000' / 1"	CHECKED -	REVISED -
	PLOT DATE = 2/6/2014	DATE -	REVISED -

STATE OF ILLINOIS
DEPARTMENT OF TRANSPORTATION

TYPICAL SECTIONS
LOCATION NO. 1 - 0.61 MI. EAST OF I-64 TO IL 127

SCALE: SHEET NO. OF SHEETS STA. TO STA.

F.A. RTE.	SECTION	COUNTY	TOTAL SHEETS	SHEET NO.
•	(109,110)RS-1, 31-2RS	WASHINGTON	40	15
•	FAP 690/FAS 819/FAP 322	CONTRACT NO. 76G61		
FED. ROAD DIST. NO. ILLINOIS FED. AID PROJECT				