

LED SIGN WIRING DETAIL

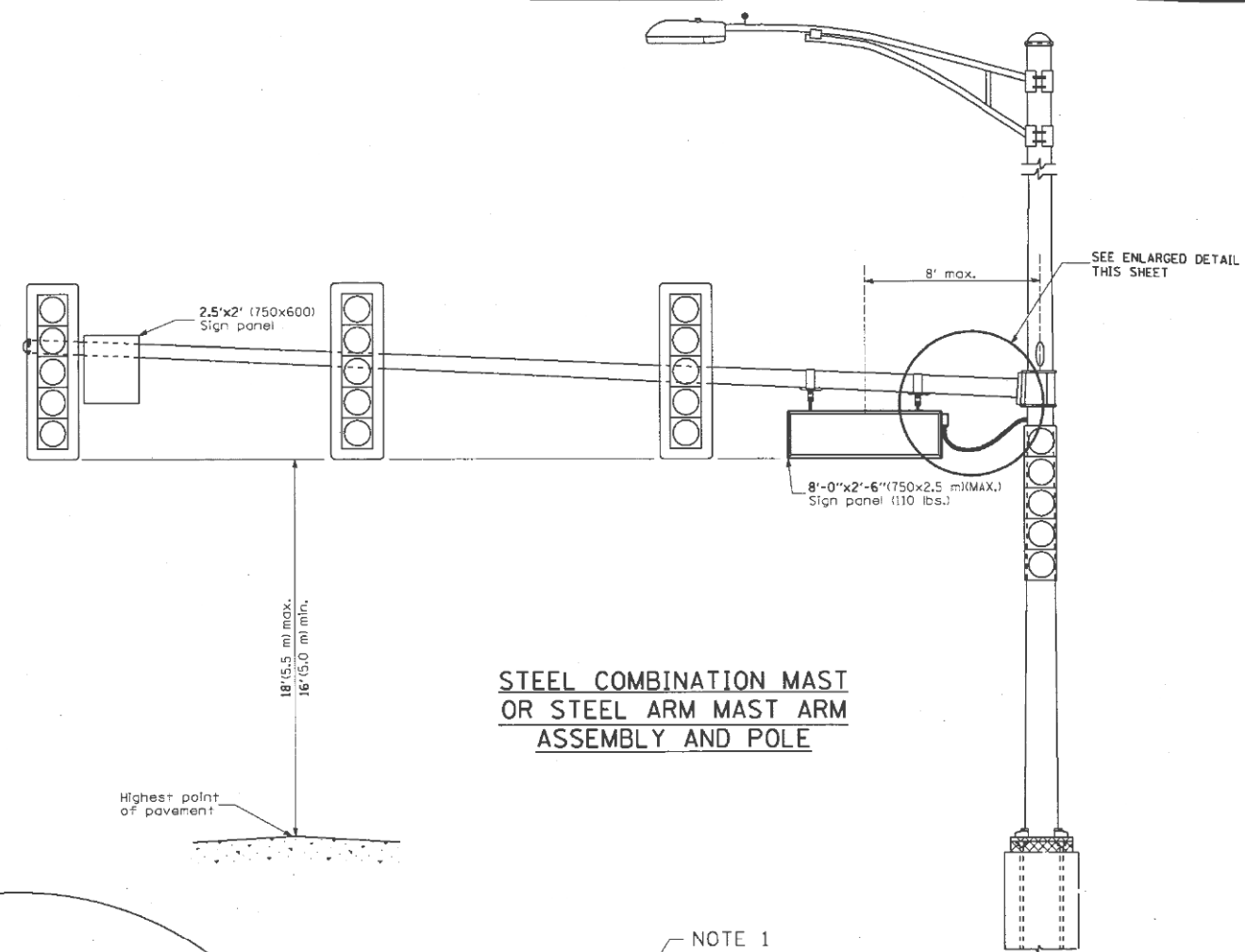

STEEL COMBINATION MAST OR STEEL ARM MAST ARM ASSEMBLY AND POLE

DESCRIPTION	MANUFACTURER	MODEL	NOTES
① CIRCUIT BREAKER		15 AMPERE	Molded case, Thermal Mag. min. R.I. of 14K R.M.S. symmetrical ampere at 277V.
② TERMINAL BLOCK	MARATHON	1502 DJSV	
③ PHOTO ELECTRIC CONTROL	FISHER PIERCE	B124-1.5-07762	
④ CONTROL RELAY	SQUARE D	8501X020V02	BOLT ON W/SCREW TERMINAL
⑤ INLINE FUSE HOLDER WITH 5 AMP FUSE	BUSSMAN	S-8000 BK/S-8-3-4-R	
⑥ ELECTRIC CABLE, NO. 14, 3/C (BLACK, WHITE, GREEN)	CAROLPRENE/SOOW	02762	
⑦ SIGN MOUNTING HARDWARE	PELCO	SE-5015	S.S. HARDWARE

BILL OF MATERIALS

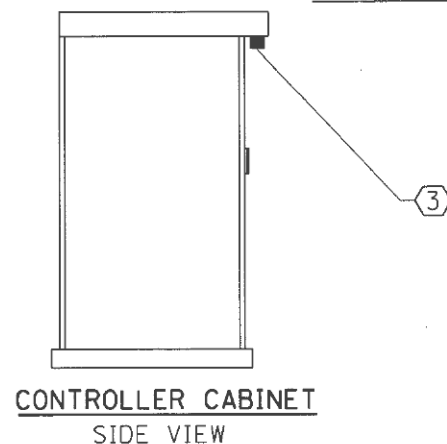

CONTROLLER CABINET SIDE VIEW

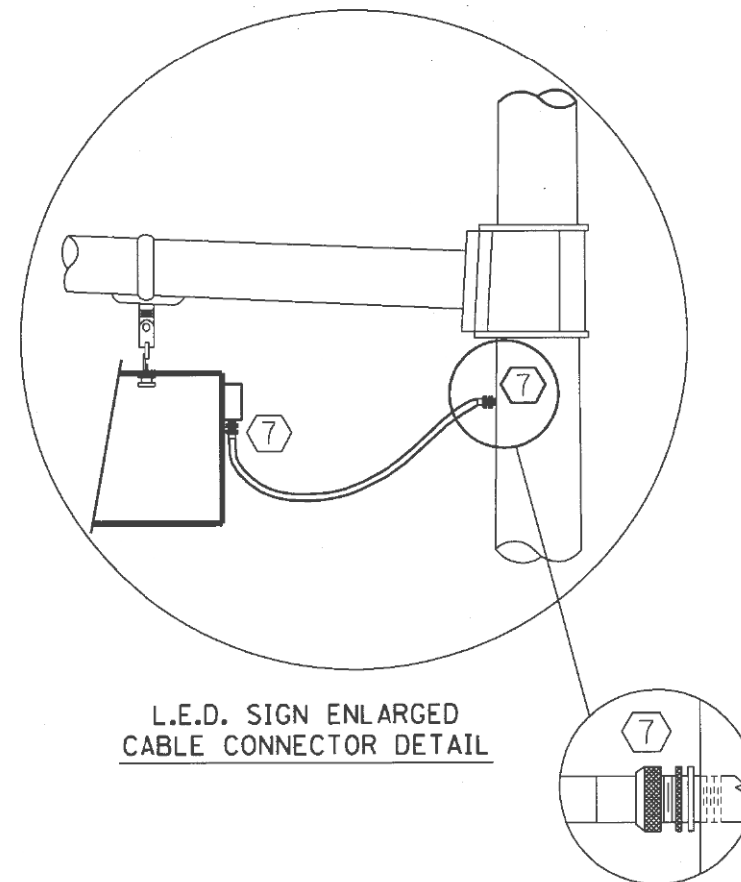

L.E.D. SIGN ENLARGED CABLE CONNECTOR DETAIL

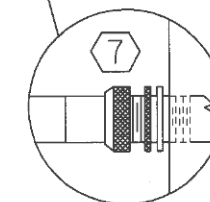

L.E.D. SIGN ENLARGED CABLE CONNECTOR DETAIL

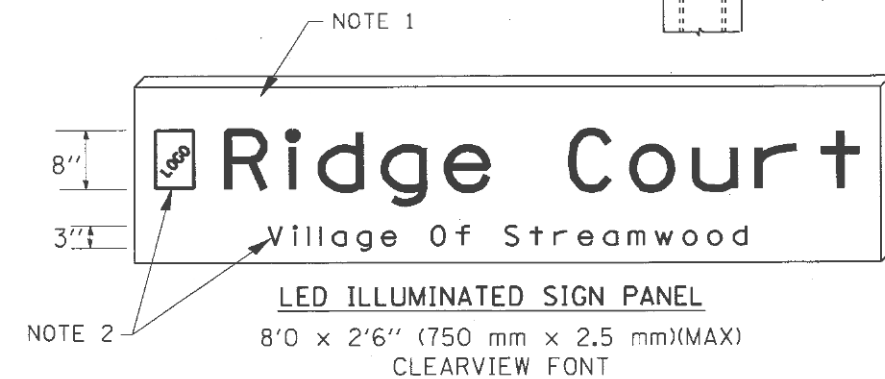

LED ILLUMINATED SIGN PANEL
8'0" x 2'6" (750 mm x 2.5 mm)(MAX)
CLEARVIEW FONT

NOTES:

- SIGNS SHALL BE DUAL SIDED. FRONT AND BACK OF SIGN WILL BE THE SAME.
- CERTAIN ADDITIONAL INFORMATION MAY BE ALLOWED ON THE SIGN. VERIFY WITH ENGINEER.
- SIGNS SHALL NOT BE ENERGIZED WHEN TRAFFIC SIGNALS ARE POWERED BY THE UPS. THE SIGNS SHALL BE CONNECTED TO THE UPS BYPASS CIRCUITRY.
- ALL WIRING WITHIN THE CABINET SHALL BE COLOR CODED AS INDICATED:
R = RED BL = BLUE W = WHITE
B = BLACK Y = YELLOW G = GREEN
- ALL 120 VOLT SYSTEM AND ALL CONTROL WIRING SHALL BE #12AWG STRANDED UNLESS OTHERWISE INDICATED.
- ALL WIRING SHALL BE NEATLY DRESSED AND SUPPORTED.