

EXISTING TYPICAL SECTION
WOLF ROAD
STA. 28+94 TO STA. 30+60

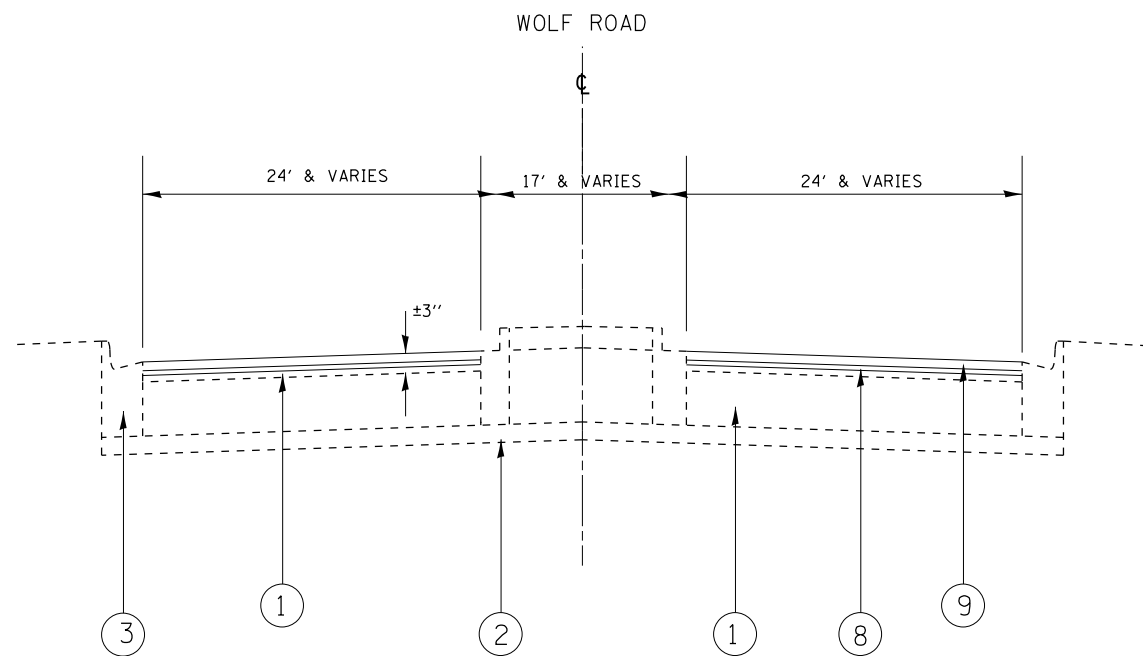

PROPOSED TYPICAL SECTION
WOLF ROAD
STA. 28+94 TO STA. 30+60

LEGEND:

- ① EXISTING P.C.C. PAVEMENT, 10"
- ② EXISTING STABILIZED SUB-BASE
- ③ EXISTING COMBINATION CONCRETE CURB AND GUTTER, TYPE B-6.12
- ④ EXISTING LANDSCAPE MEDIAN
- ⑤ EXISTING HOT-MIX ASPHALT SURFACE, ±3"
- ⑥ PROPOSED HOT-MIX ASPHALT SURFACE REMOVAL, 2 1/4"
- ⑦ PROPOSED POLYMERIZED LEVELING BINDER (MACHINE METHOD), IL-4.75, N50, 1"
- ⑧ PROPOSED POLYMERIZED LEVELING BINDER (MACHINE METHOD), IL-4.75, N50, 3/4"
- ⑨ PROPOSED HOT-MIX ASPHALT SURFACE COURSE, MIX "D", N70, 1 1/2"
- ⑩ PROPOSED P.C.C. SURFACE REMOVAL (VARIABLE DEPTH)
(SEE 'HMA TAPER AT EDGE OF P.C.C. PAVEMENT' DETAIL)
- ⑪ PROPOSED MEDIAN REMOVAL, PARTIAL DEPTH

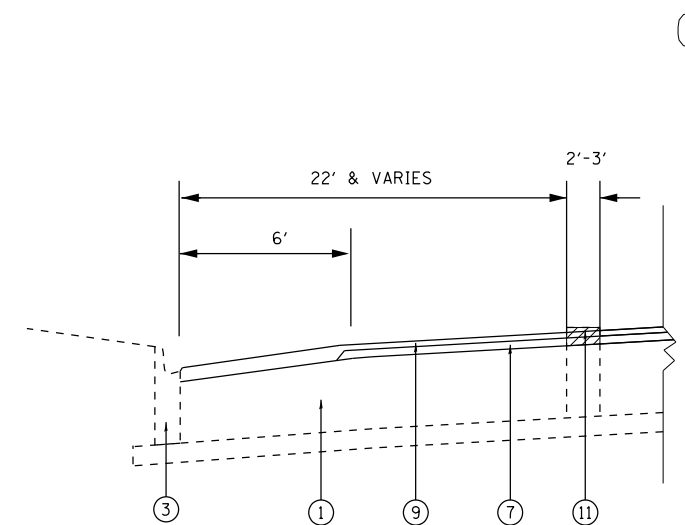

PROPOSED MEDIAN REMOVAL, PARTIAL DEPTH
(TO BE OVERLAID AND REPLACED WITH THERMOPLASTIC PAVEMENT MARKING - LINE 6" (TYP))

NOTE:
CONTRACTOR SHALL PATCH BEFORE MILLING.

FILE NAME =	USER NAME = rodriguezma	DESIGNED -	REVISED -	STATE OF ILLINOIS DEPARTMENT OF TRANSPORTATION	WOLF ROAD - HARRISON STREET TO IL. RTE 38 (ROOSEVELT ROAD) TYPICAL SECTIONS	F.A.U. RTE.	SECTION	COUNTY	TOTAL SHEETS	SHEET NO.
et:\pw\work\p\dot\rodriguezma\d0246730\109711-sht-plan.dgn		DRAWN -	REVISED -			2689	(3185 & 3186) RS-3	COOK	20	6
PLOT SCALE = 100.0000' / in.		CHECKED -	REVISED -			CONTRACT NO. 60M30				
PLOT DATE = 12/28/2012		DATE -	REVISED -			ILLINOIS FED. AID PROJECT				