



**LEGEND:**

- PROPOSED LIGHTING UNIT: 400W, 240V PHASE TO NEUTRAL, HPS LUMINAIRE WITH TYPE III DISTRIBUTION, 45'-2" ALUMINUM POLE SHAFT ON 24" DIAMETER CONCRETE FOUNDATION, 47'-6" MOUNTING HEIGHT, 12'-0" MAST ARM, WITH 5A FUSES AND T-BASE (RED PHASE-OPEN SYMBOL, BLACK PHASE-SHADED SYMBOL)
- PROPOSED 120V, 20A, GFCI RECEPTACLE ON PROPOSED LIGHTING UNIT (ORANGE PHASE-OPEN SYMBOL, BROWN PHASE-SHADED SYMBOL)
- PROPOSED ROADWAY LIGHTING UNIT INSTALLED IN EARLIER CONSTRUCTION STAGE
- PROPOSED ROADWAY LIGHTING CONTROLLER INSTALLED IN EARLIER CONSTRUCTION STAGE
- PROPOSED COMED PAD-MOUNTED TRANSFORMER FOR UTILITY SERVICE CONNECTION INSTALLED IN EARLIER CONSTRUCTION STAGE
- PROPOSED CONDUIT AND CABLE TO SECONDARY SIDE OF UTILITY SERVICE CONNECTION INSTALLED IN EARLIER CONSTRUCTION STAGE
- PROPOSED UNIT DUCT: SIZE AND QUANTITY OF CONDUCTORS AS INDICATED
- PROPOSED UNIT DUCT INSTALLED IN EARLIER CONSTRUCTION STAGE

**NOTES:**

1. SEE DRAWING E-1 FOR ELECTRICAL ABBREVIATIONS, SEE DRAWING E-2 FOR ELECTRICAL GENERAL NOTES.
2. COLOR CODING OF CONDUCTORS FOR 240/480V, 1Ø, 3W LIGHTING SYSTEM IS AS FOLLOWS:  
 "A" PHASE - RED  
 "B" PHASE - BLACK  
 NEUTRAL - WHITE  
 GROUND - GREEN
3. COLOR CODING OF CONDUCTORS FOR 120/240V, 1Ø, 3W RECEPTACLE SYSTEM IS AS FOLLOWS:  
 "A" PHASE - ORANGE  
 "B" PHASE - BROWN  
 NEUTRAL - GRAY  
 GROUND - GREEN

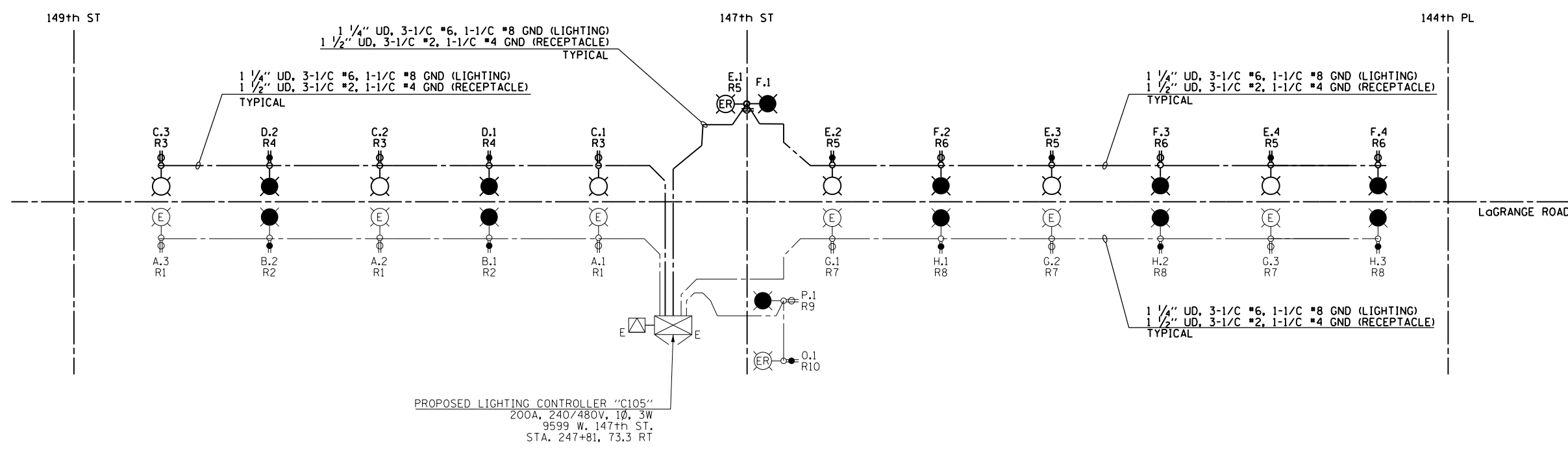

PROPOSED LIGHTING CONTROLLER "C105"  
 200A, 240/480V, 1Ø, 3W  
 9599 W. 147th ST.  
 STA. 247+81, 73.3 RT

**LIGHTING CONTROLLER "C105" STAGE 3 WIRING DIAGRAM**  
 N.T.S.

CIRCUIT	RED PHASE		CIRCUIT	BLACK PHASE	
	AMPS	WATTS		AMPS	WATTS
A	6	1440	B	4	960
C	6	1440	D	4	960
E	8.2	1968	F	8.2	1968
G	6	1440	H	6	1440
I	--	--	J	--	--
K	--	--	L	--	--
M	--	--	N	--	--
O	1.1	250	P	1.1	250
Q	--	--	R	--	--
S	--	--	T	--	--
U	--	--	V	--	--
W	10.5	2520	X	9	2160
<b>TOTAL</b>	<b>37.8</b>	<b>9072</b>	<b>TOTAL</b>	<b>32.3</b>	<b>7752</b>

LOAD TABULATION IS BASED ON THE FOLLOWING:  
 400W HPS LUMINAIRE: 2.0A AT 240V  
 250W HPS LUMINAIRE: 1.1A AT 240V

CIRCUIT	ORANGE PHASE		CIRCUIT	BROWN PHASE	
	AMPS	WATTS		AMPS	WATTS
R1	4.5	540	R2	3	360
R3	4.5	540	R4	3	360
R5	7.5	900	R6	7.5	900
R7	3	360	R8	3	360
R9	1.5	180	R10	1.5	180
R11	--	--	R12	--	--
R13	--	--	R14	--	--
R15	--	--	R16	--	--
R17	--	--	R18	--	--
<b>TOTAL</b>	<b>21</b>	<b>2520</b>	<b>TOTAL</b>	<b>18</b>	<b>2160</b>

LOAD TABULATION IS BASED ON THE FOLLOWING:  
 180W RECEPTACLE: 1.5A AT 120V  
 • FOR FUTURE MEDIAN RECEPTACLE LOADS

100 S. WACKER DR.  
 SUITE 500  
 CHICAGO, IL 60606  
 TEL (312) 939-1000  
 FAX (312) 939-4998  
**URS**