

PARAPET RAILING
ELEVATION
(Inside Face of Rail)

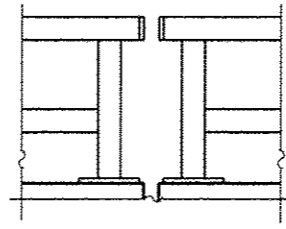

PARAPET RAILING
ELEVATION AT EXPANSION JOINT

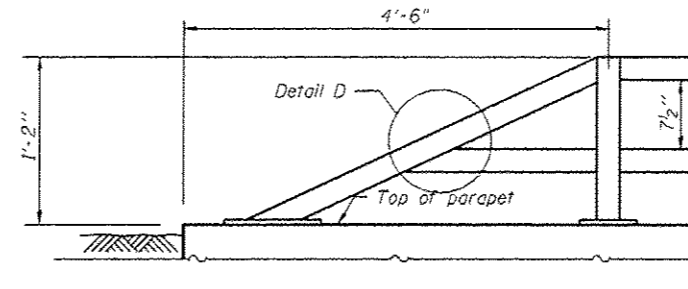

PARAPET RAILING
AT END SECTION

Note:
All post, railing, splices, anchor devices, and bent plates shall be painted using the inorganic zinc-rich/waterborne acrylic paint system as described in the special provision "Cleaning and Painting New Metal Structures." Color of painted railing to be black.

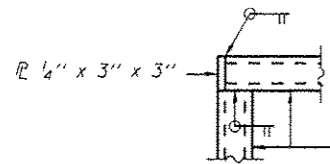

DETAIL A

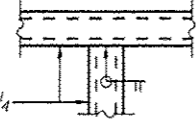

DETAIL B

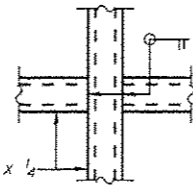

DETAIL C

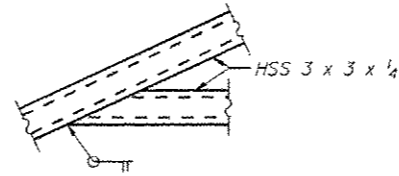

DETAIL D

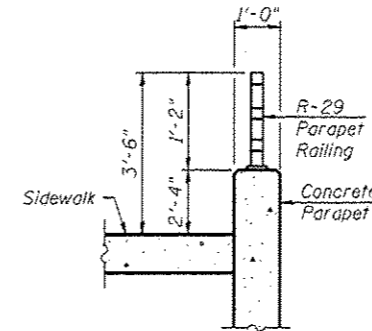

SECTION THRU RAILING

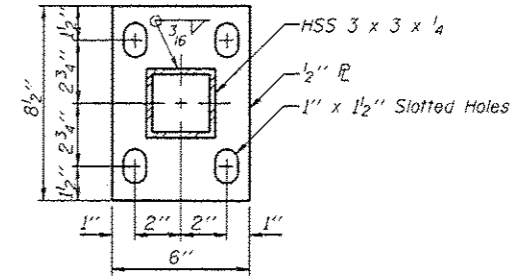

BASE P

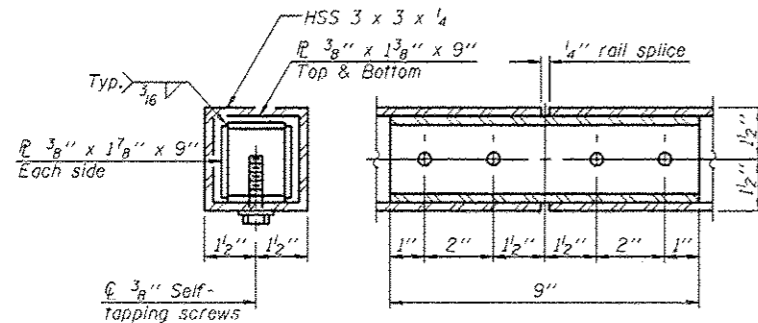

RAIL SPLICE

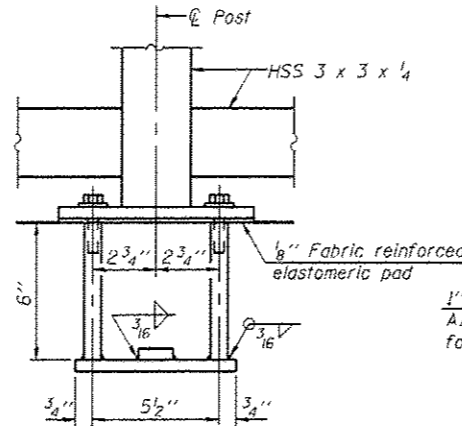

ANCHOR BOLT DETAILS

In lieu of the cast-in-place anchor device shown, the Contractor has the option of drilling and setting 5/8" ϕ anchor rods according to Article 509.06 of the Standard Specifications. Embedment shall be according to the manufacturer's specifications.

