

METAL SHELL PILE TABLE

Designation and outside diameter	Wall thickness t	Weight per foot (Lbs./ft.)	Inside volume (yd. ³ /ft.)
PP12	0.179"	22.60	0.0274
PP12	0.250"	31.37	0.0267
PP14	0.250"	36.71	0.0368
PP14	0.312"	45.61	0.0361

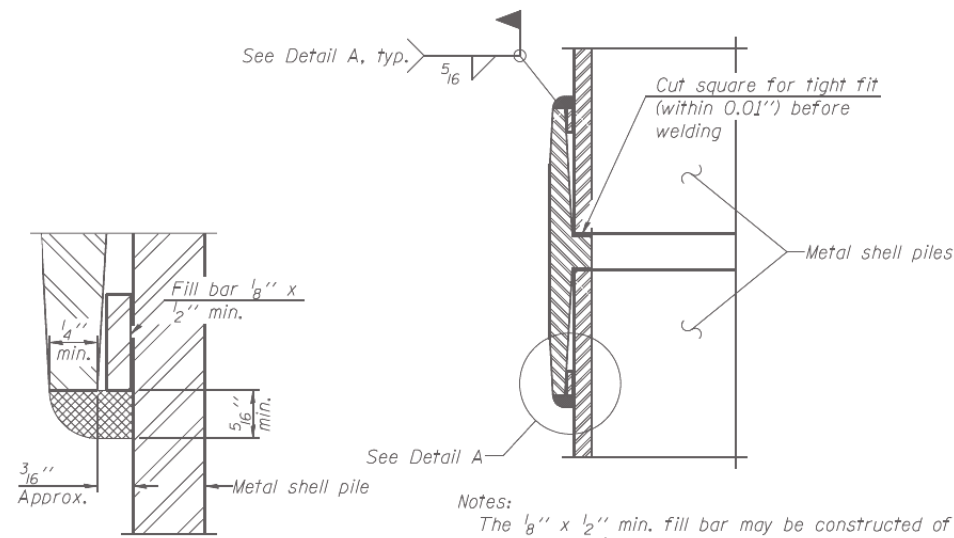

Notes:
 The $\frac{1}{8}$ " x $\frac{1}{2}$ " min. fill bar may be constructed of 2 bars with a $\frac{1}{8}$ " max. gap between them.
 Pile segments shall be driven to solid contact with splicer before welding.

DETAIL A

WELDED COMMERCIAL SPLICE

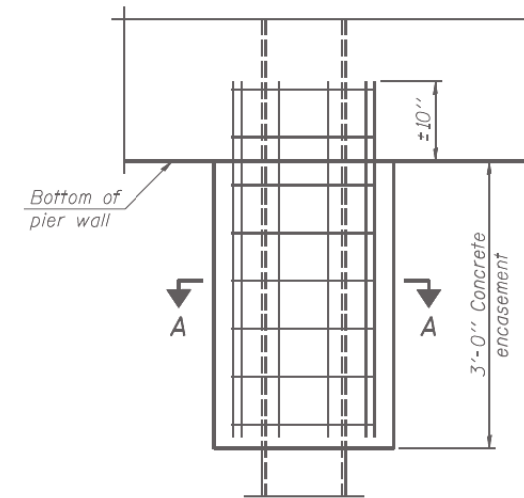

ELEVATION

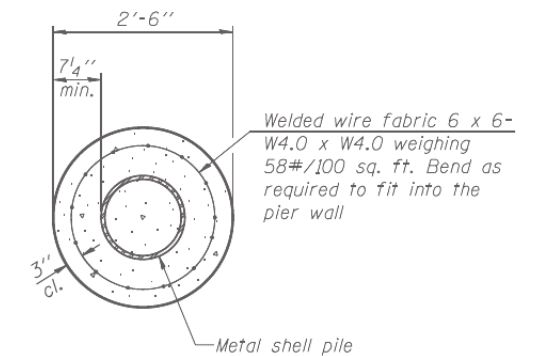

SECTION A-A

Note:
 Forms for encasement may be omitted when soil conditions permit.

CONCRETE ENCASEMENT AT PIERS

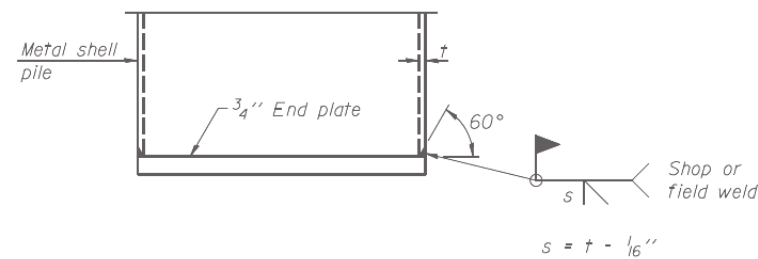

END PLATE ATTACHMENT

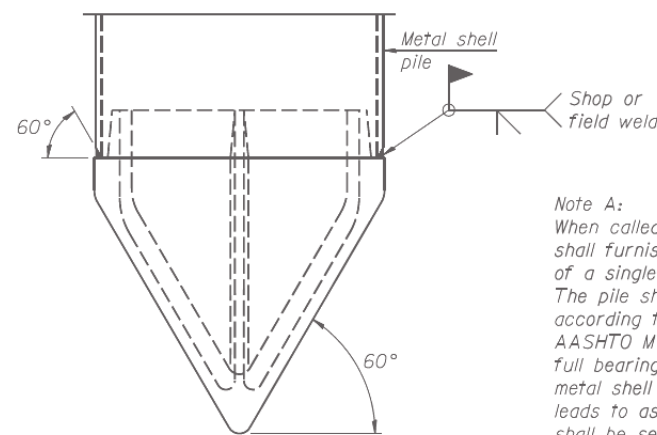

Note A:
 When called for on the plans, the Contractor shall furnish metal shell pile shoes consisting of a single piece conical pile point as shown. The pile shoes shall be cast in one piece steel according to either ASTM A 148 Grade 90-60 or AASHTO M 103 Grade 65-35 and shall provide full bearing over the full circumference of the metal shell pile. The pile shoe shall have tapered leads to assure proper alignment and fitting and shall be secured to the pile with a circumferential weld.

METAL SHELL PILE SHOE ATTACHMENT

(See Note A)

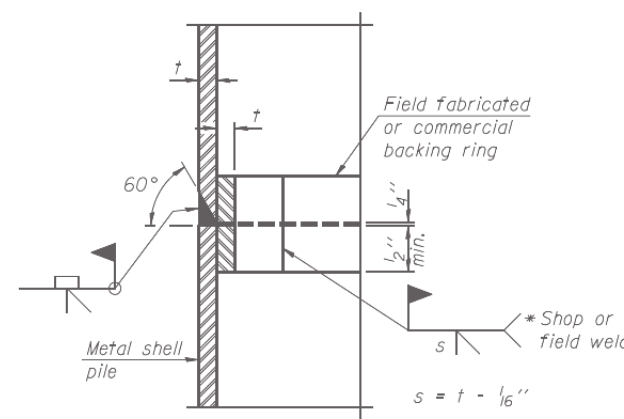

COMPLETE PENETRATION WELD SPLICE

* Field fabricated backing ring may be made from pile shell by removing segment to allow reducing circumference and vertically rejoin with partial joint penetration weld.

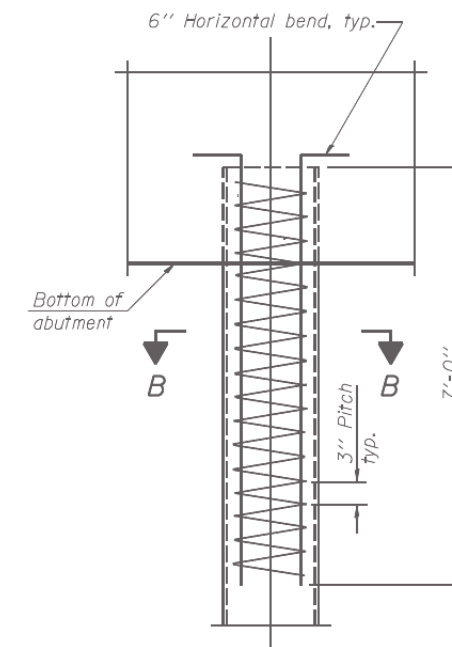

ELEVATION

METAL SHELL REINFORCEMENT AT ABUTMENTS

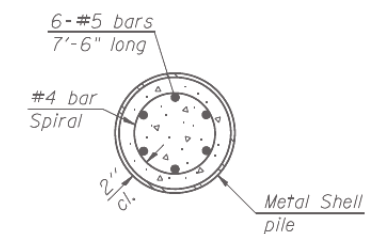

SECTION B-B

Note:
 The metal shell piles shall be according to ASTM A 252 Grade 3.

F-MS 7-1-10



USER NAME =	DESIGNED - LRT/AG	REVISED -
PLOT SCALE =	CHECKED - OAC	REVISED -
PLOT DATE =	DRAWN - TCS/AG	REVISED -
	CHECKED - LRT	REVISED -

STATE OF ILLINOIS
 DEPARTMENT OF TRANSPORTATION

METAL SHELL PILE DETAILS

SHEET NO. 5 OF 6 SHEETS

F.A.P. RTE.	SECTION	COUNTY	TOTAL SHEETS	SHEET NO.
330	103R-4	COOK	877	540
CONTRACT NO. 60M61				

ILLINOIS FED. AID PROJECT