

**SOLDIER PILE SCHEDULE**

Soldier Pile Data						Concrete Encasement Data		
Pile No.	Pile Size	Top of Pile Elevation	Pile Tip Elevation	Pile Length (Ft.)	No. of Studs	Diameter (In.)	Top of Encasement Elevation	Encasement Length
P1	W18x46	682.84	667.07	15.77	2	24	682.82	15.75
P2	W18x46	683.64	666.71	16.93	4	24	682.46	15.75
P3	W18x46	683.82	666.35	17.47	4	24	682.10	15.75
P4	W18x46	684.01	666.02	17.99	6	24	681.77	15.75
P5	W18x46	684.22	665.73	18.49	6	24	681.48	15.75
P6	W18x46	684.42	665.44	18.98	8	24	681.19	15.75
P7	W18x76	684.66	663.47	21.19	8	30	680.97	17.50
P8	W18x76	684.93	663.33	21.60	10	30	680.83	17.50
P9	W18x76	685.20	663.19	22.01	10	30	680.69	17.50
P10	W21x93	685.43	661.55	23.88	10	30	680.55	19.00
P11	W21x93	685.63	661.43	24.21	12	30	680.43	19.00
P12	W21x93	685.84	661.30	24.53	12	30	680.30	19.00
P13	W21x93	686.00	661.20	24.80	12	30	680.20	19.00
P14	W21x93	686.12	661.11	25.01	14	30	680.11	19.00
P15	W21x93	686.24	661.02	25.22	14	30	680.02	19.00
P16	W21x93	686.37	660.94	25.43	14	30	679.94	19.00
P17	W24x104	686.56	659.60	26.96	14	36	679.85	20.25
P18	W24x104	686.84	659.52	27.32	16	36	679.77	20.25
P19	W24x104	687.11	659.44	27.67	16	36	679.69	20.25
P20	W24x104	687.38	659.35	28.03	16	36	679.60	20.25
P21	W24x131	687.66	657.52	30.14	18	36	679.52	22.00
P22	W24x131	687.94	657.44	30.50	18	36	679.44	22.00
P23	W24x131	688.22	657.36	30.87	18	36	679.36	22.00
P24	W24x131	688.50	657.27	31.23	20	36	679.27	22.00
P25	W27x146	688.76	656.95	31.81	20	36	679.20	22.25
P26	W27x146	689.09	656.86	32.23	20	36	679.11	22.25
P27	W27x146	689.38	656.78	32.61	22	36	679.03	22.25
P28	W27x146	689.68	656.69	32.99	22	36	678.94	22.25
P29	W27x146	689.96	654.86	35.09	24	36	678.86	24.00
P30	W27x146	690.21	654.78	35.43	24	36	678.78	24.00
P31	W27x146	690.47	654.70	35.77	24	36	678.70	24.00
P32	W27x146	690.72	654.62	36.10	26	36	678.62	24.00
P33	W30x173	690.96	652.78	38.18	26	42	678.53	25.75
P34	W30x173	691.19	652.70	38.49	26	42	678.45	25.75
P35	W30x173	691.42	652.62	38.79	28	42	678.37	25.75
P36	W30x173	691.65	652.54	39.10	28	42	678.29	25.75
P37	W33x201	691.88	649.72	42.16	28	42	678.22	28.50
P38	W33x201	692.12	649.64	42.48	28	42	678.14	28.50
P39	W33x201	692.36	649.57	42.79	30	42	678.07	28.50
P40	W33x201	692.60	649.50	43.10	30	42	678.00	28.50
P41	W36x262	692.84	647.10	45.74	30	48	677.93	30.83
P42	W36x262	693.08	647.03	46.05	32	48	677.86	30.83
P43	W36x262	693.33	646.96	46.37	32	48	677.79	30.83
P44	W36x262	693.57	646.89	46.68	32	48	677.72	30.83
P45	W36x262	694.87	643.83	51.05	36	48	677.66	33.83
P46	W36x262	695.64	643.77	51.86	38	48	677.60	33.83
P47	W36x262	696.40	643.72	52.68	38	48	677.55	33.83

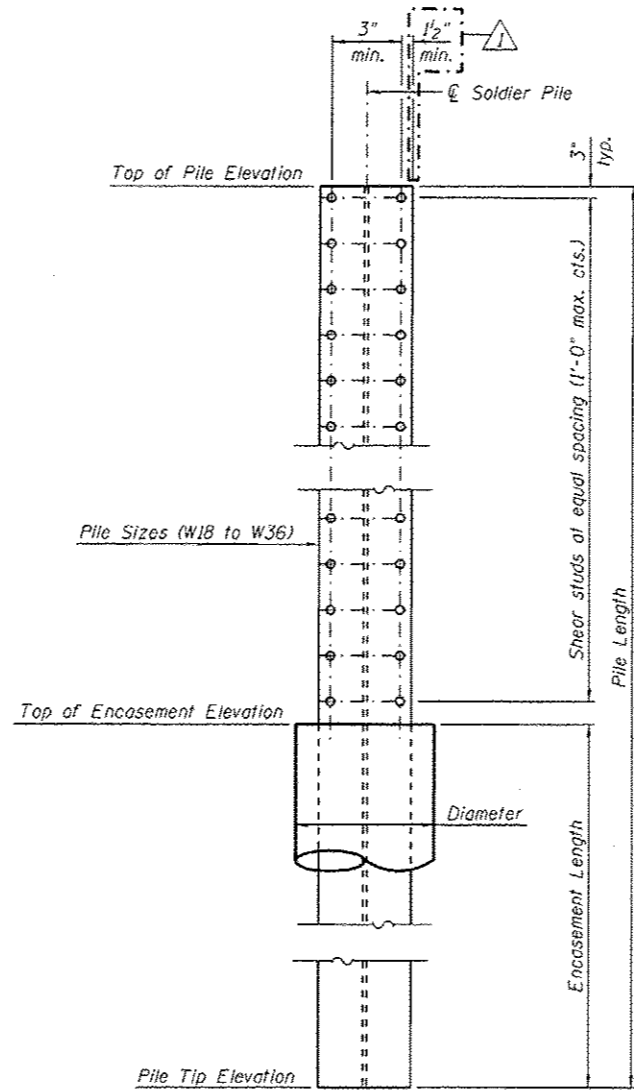

**SOLDIER PILE ELEVATION AND SHEAR STUD CONNECTION DETAILS**

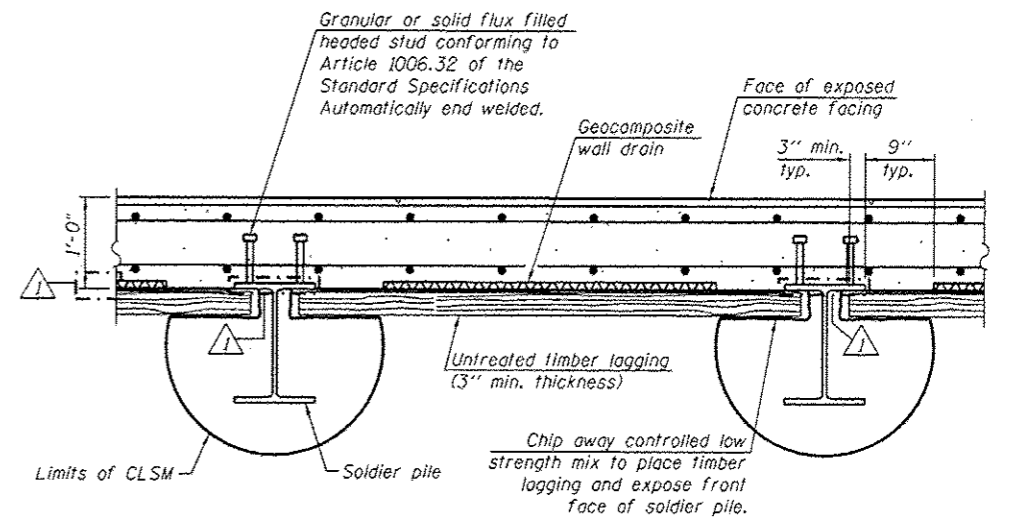

**DETAIL PLAN**

URS  
100 S. WACKER DR.  
SUITE 500  
CHICAGO, IL 60606  
TEL (312) 999-0000  
FAX (312) 999-4088

FILE NAME : 016Z002-00MG2-005-del.dgn	USER NAME : orsalan.khan	DESIGNED - KJH	REVISED - / 04/12/2013 P.M.H.
		CHECKED - PMH	REVISED -
		DRAWN - RJ	REVISED -
		CHECKED - MJL	REVISED -

STATE OF ILLINOIS  
DEPARTMENT OF TRANSPORTATION

PILE SCHEDULE & DETAILS  
STRUCTURE NO. 016-Z002

SHEET NO. 5 OF 9 SHEETS

F.A.P. RTE. 330	SECTION 103R-5	COUNTY COOK	TOTAL SHEETS 778	SHEET NO. 398
				CONTRACT NO. 60M62
ILLINOIS FED. AID PROJECT				