

WINGWALL ELEVATION
(Front Face shown)

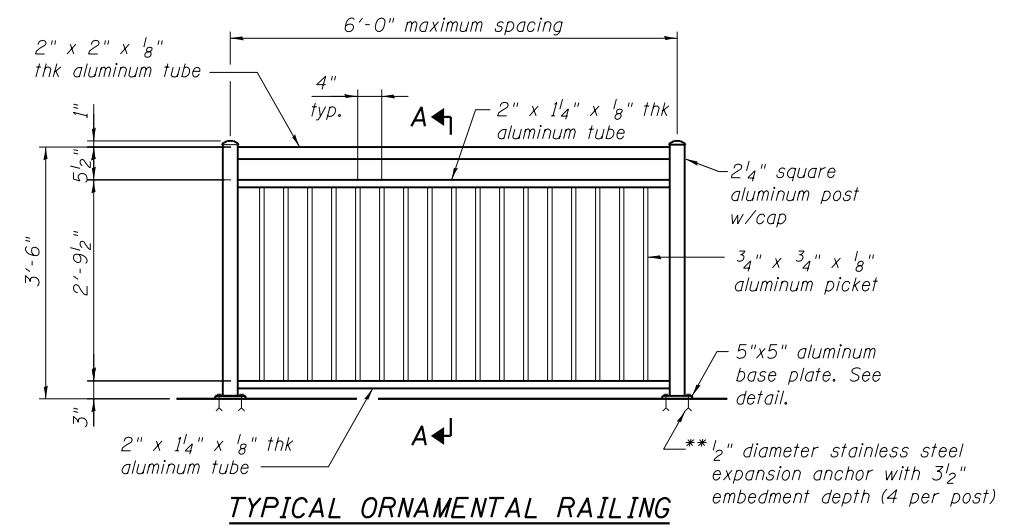
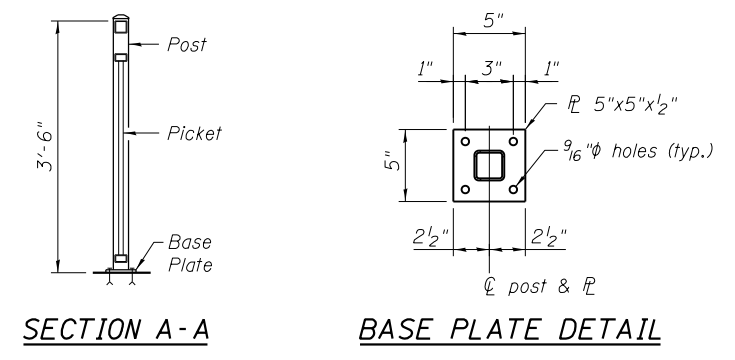

** At existing wall, Contractor shall drill and set 1/2" ϕ anchor rods according to Article 509.06 of the Standard Specifications. Embedment shall be according to the manufacturer's specifications.

URS
 100 S. WACKER DR.
 SUITE 600
 CHICAGO, IL 60606
 TEL (312) 935-1000
 FAX (312) 935-4198

FILE NAME =	USER NAME = Anthony.Plutz	DESIGNED - PMH	REVISED -
0162003-60M62-006-Rail.dgn		CHECKED - NRP	REVISED -
	PLOT SCALE = 12,500' / 1" =	DRAWN - PMH	REVISED -
	PLOT DATE = 3/13/2013	CHECKED - NRP	REVISED -

**STATE OF ILLINOIS
DEPARTMENT OF TRANSPORTATION**

**RAILING DETAILS
STRUCTURE NO. 016-2003**

SHEET NO. 6 OF 7 SHEETS

F.A.P. RTE.	SECTION	COUNTY	TOTAL SHEETS	SHEET NO.
330	103R-5	COOK	778	408
CONTRACT NO. 60M62				
ILLINOIS FED. AID PROJECT				