

**WINGWALL ELEVATION**  
(Front Face shown)

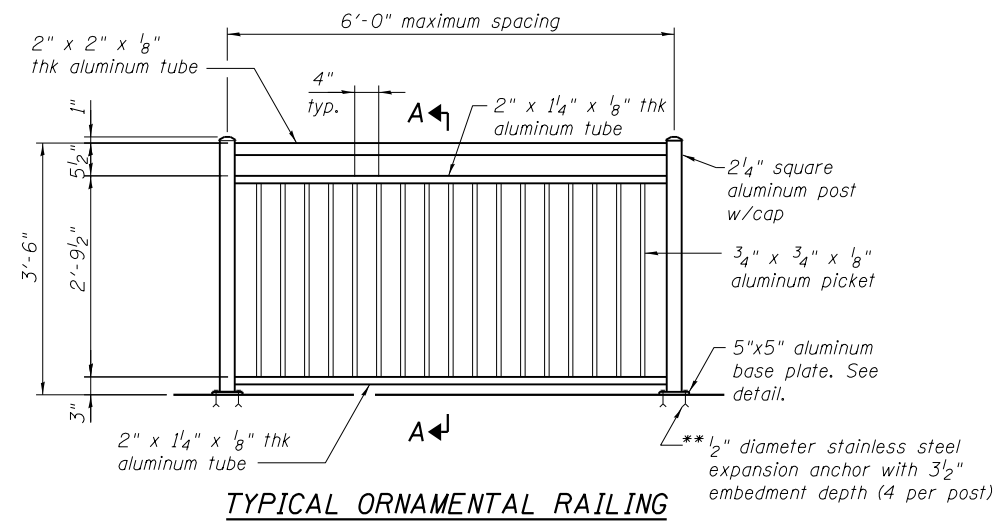
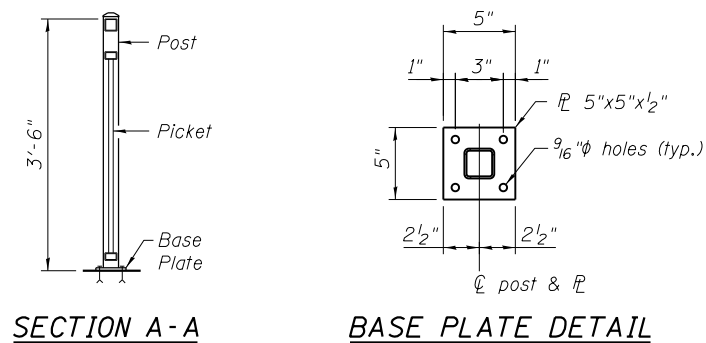

\*\* At existing wall, Contractor shall drill and set 1/2"  $\phi$  anchor rods according to Article 509.06 of the Standard Specifications. Embedment shall be according to the manufacturer's specifications.

FILE NAME =	USER NAME = Anthony.Plutz	DESIGNED - PMH	REVISED -
0162004-60M62-007-rail.dgn		CHECKED - NPP	REVISED -
	PLOT SCALE = 12,500' / in.	DRAWN - PMH	REVISED -
	PLOT DATE = 3/13/2013	CHECKED - NPP	REVISED -

F.A.P. RTE.	SECTION	COUNTY	TOTAL SHEETS	SHEET NO.
330	103R-5	COOK	778	416
CONTRACT NO. 60M62			ILLINOIS FED. AID PROJECT	