

EXISTING TYPICAL SECTION
STA. 452+26.87 TO STA. 452+89.22

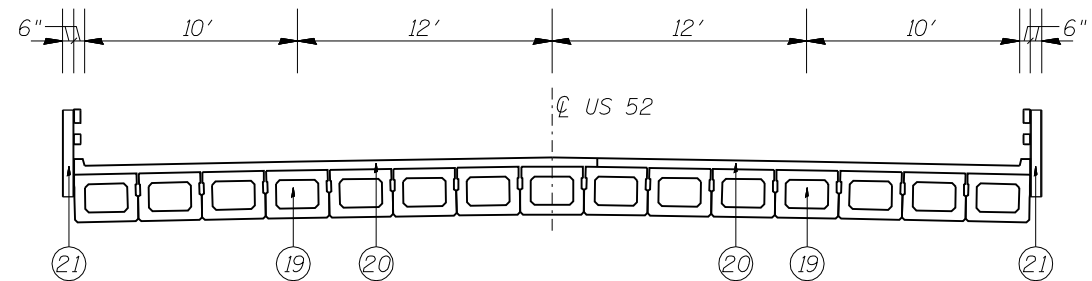

PROPOSED TYPICAL SECTION
STA. 452+26.87 TO STA. 452+89.22

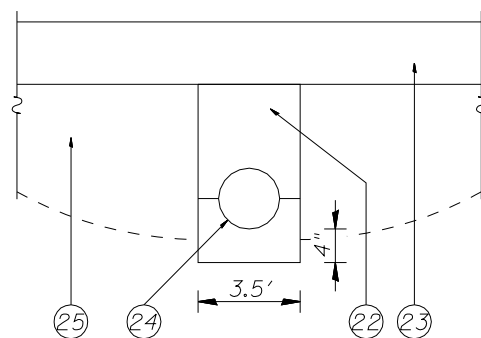

PROPOSED DRIVEWAY SECTION
STA. 448+82 TO STA. 449+18

LEGEND

- ⑦ EXISTING PPC DECK BEAMS
- ⑧ EXISTING HMA WEARING SURFACE, 2"
- ⑨ EXISTING STEEL RAILING TO BE REMOVED
- ⑱ PROPOSED PPC DECK BEAMS (27" DEPTH)
- ⑳ PROPOSED CONCRETE WEARING SURFACE (5") WITH CONCRETE CURB
- ㉑ PROPOSED STEEL RAILING
- ㉒ PROPOSED TRENCH BACKFILL
- ㉓ PROPOSED AGGREGATE FOR DRIVEWAY MAINTENANCE, 10" MINIMUM
- ㉔ PROPOSED PIPE DRAINS, CORRUGATED STEEL, 24"
- ㉕ FURNISHED EXCAVATION

ROADWAY SUPERELEVATION TABLE

STATION	LEFT SHOULDER ELEVATION	LEFT EOP ELEVATION	CENTERLINE ELEVATION	RIGHT EOP ELEVATION	RIGHT SHOULDER ELEVATION
453+44.12	679.52	679.84	680.02	679.83	679.51
453+60	679.32	679.64	680.01	680.09	679.77
453+80	679.24	679.56	680.00	680.22	679.90
454+00	679.16	679.48	680.00	680.35	680.03
454+20	679.13	679.45	680.04	680.48	680.16
454+40	679.10	679.42	680.09	680.62	680.30
454+60	679.09	679.41	680.15	680.77	680.45
454+80	679.12	679.44	680.23	680.91	680.59
455+00	679.16	679.48	680.32	681.07	680.75
455+10	679.18	679.50	680.37	681.15	680.83

EARTHWORK						
STAGE	LOCATION	EARTH EXCAVATION (CUT) CU YD	ADJ. EXCAVATION 15% CU YD	REMOVAL AND DISPOSAL OF UNSUITABLE MATERIAL (CUT) CU YD	EMBANKMENT (FILL) CU YD	FURNISHED EXCAVATION CU YD
1 & 2	STA. 449+00 to 455+74	347	295	347	600	600