

**LOCATION SKETCH**

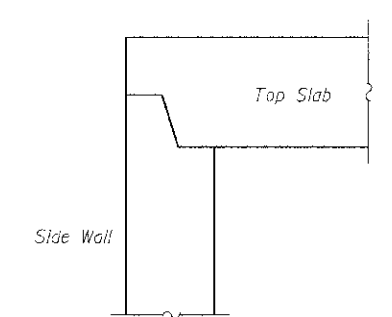

**DETAIL A**

**GENERAL NOTES**

Minimum top slab, side wall and bottom slab thicknesses given, may be increased as needed by precast manufacturer. Pavement and Invert elevations shall not be altered without Engineer's approval.

Top Slabs shall be precast as a separate unit, then place after pipe connection.

All installation methods, including backfilling requirements, shall be according to the precast manufacturer's recommendations.

Excavation, backfilling, frames, lids, and any all other work necessary to complete the work as shown will not be measured for payment, but shall be considered included with the cost of Drainage Structures, No. 2.

Adjusting rings, frames, lids and grates shall be installed in accordance with the applicable portions of Section 602 and 604 of the Standard Specifications.

Maximum applied service bearing pressure,  $Q_{max} = 2,500$  PSF

See Special Provisions for design and detailing requirements.

**DESIGN SPECIFICATIONS**  
 2010 AASHTO LRFD Bridge Design Specifications with 2011 and 2012 Interims

**CONSTRUCTION SPECIFICATIONS**  
 IDOT: "Standard Specifications for Road and Bridge Construction", Adopted January 1, 2012 and Supplemental Specifications and Recurring Special Provisions", Adopted January 1, 2012 by the Illinois Department of Transportation.

**SEISMIC DATA**  
 Seismic Performance Zone (SPZ) = 1  
 Design Spectral Acceleration at 1.0 sec. ( $S_{D1}$ ) = 0.083g  
 Design Spectral Acceleration at 0.2 sec. ( $S_{D5}$ ) = 0.145g  
 Soil Site Class = D

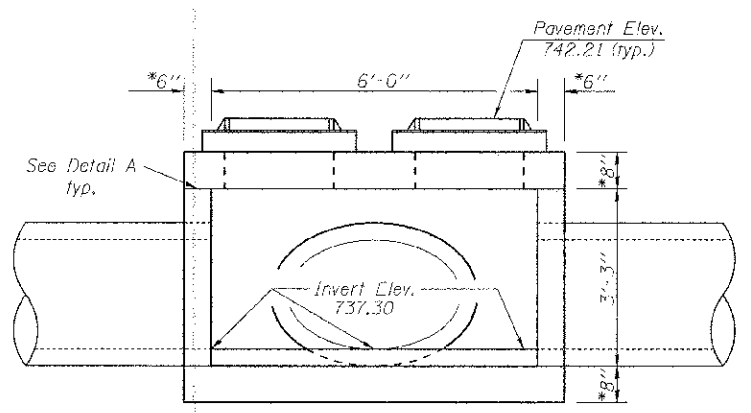

**SECTION B-B**

**LOADING HL-93**  
 Allow 50#/sq. ft. for future wearing surface.

**MATERIALS**

Precast Concrete Drainage Structure shall be Designed, Constructed, and Installed in Accordance with Manufacturer Specifications. The Structure shown on the Drawings is for general arrangement purposes only. (See Special Provisions)

**BILL OF MATERIAL**

Item	Unit	Quantity
Drainage Structures, No. 2	Each	1

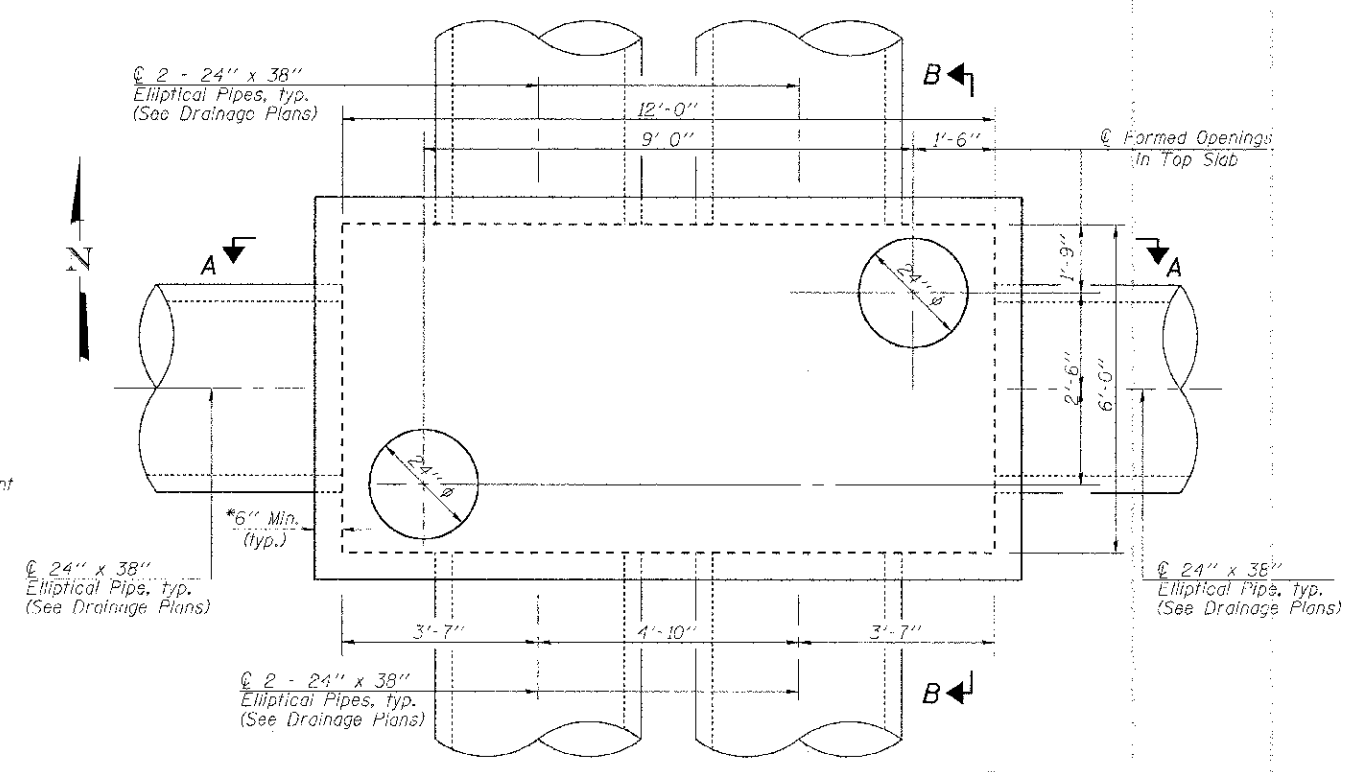

**PLAN**

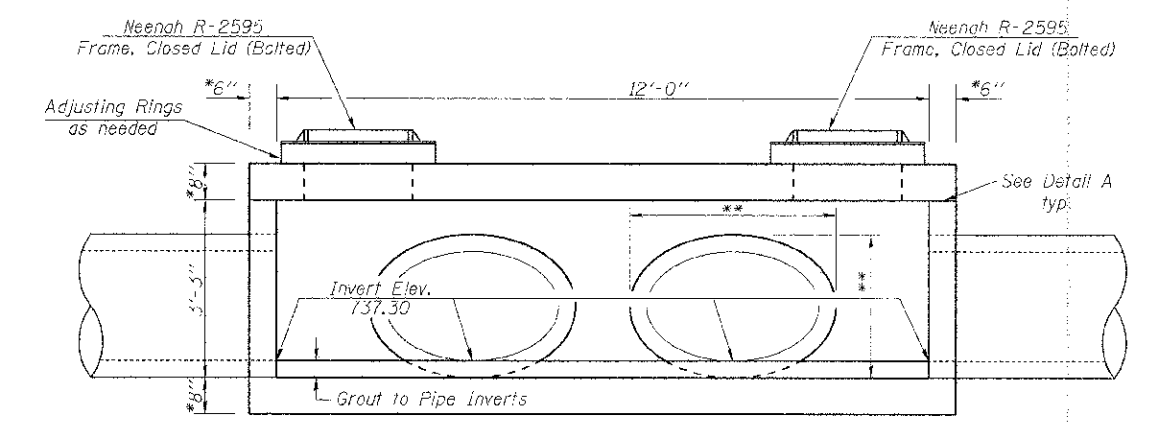

**SECTION A-A**

\* May be increased according to Precast Manufacturer's requirements

\*\* Coordinate size of formed openings with out-to-out dimensions specified by Pipe Manufacturer.

FILE NAME	USER NAME	DESIGNED -	REVISED -	<b>STATE OF ILLINOIS DEPARTMENT OF TRANSPORTATION</b>	<b>PRECAST CONCRETE DRAINAGE STRUCTURES BOX "B"</b>	F.A.I. REC.	SECTION	COUNTY	TOTAL SHEET NO.	
		CHECKED -	REVISED -			4006	95-00049-00-PV	KANE	138	98
PLT. DATE		DRAWN -	REVISED -			CONTRACT NO. 63745				
		CHECKED -	REVISED -			SHEET NO. 1 OF 1 SHEETS				