

NOTE:  
THE TOP 2 INCHES OF MIX SHALL BE HOT-MIX ASPHALT SURFACE COURSE WHEN THE STREET BEING REPAIRED WILL NOT BE RESURFACED UNDER THIS CONTRACT.

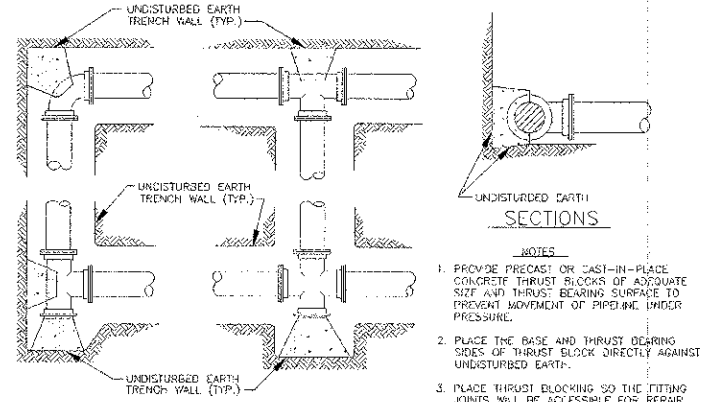
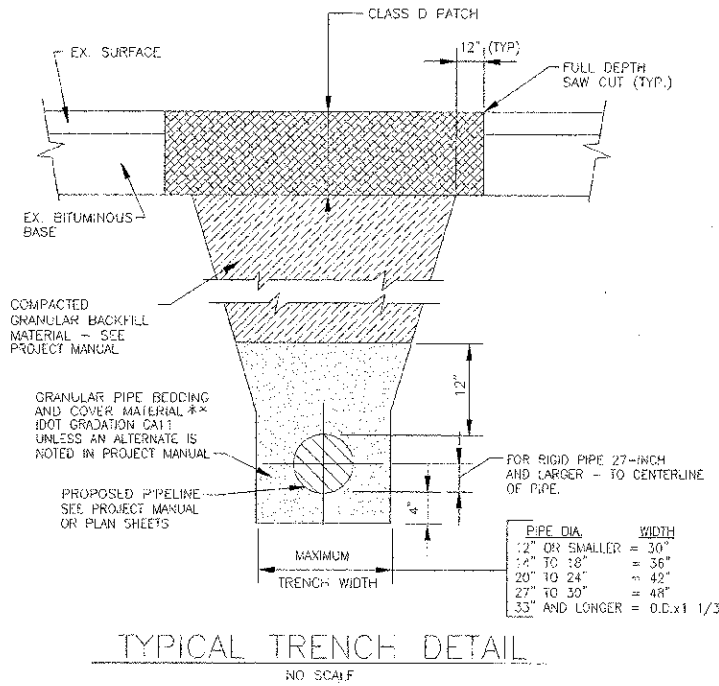
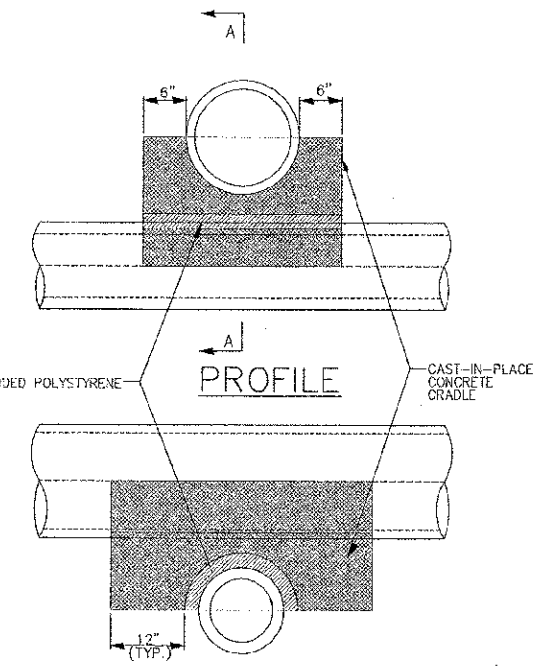
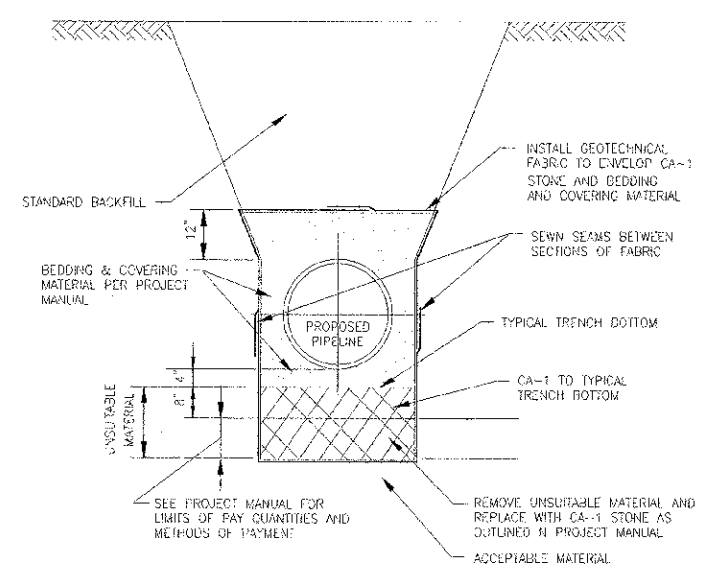

\* TO BE USED WHEN CLEARANCE BETWEEN PIPES IS 6" OR LESS

\*\* FOR FLEXIBLE THERMOPLASTIC PIPE COMPLY WITH ASTM D2321, CLASS 1A, 1B, OR II, (DOT GRADATION CA15)

FOR RIGID PIPE COMPLY WITH ASTM C12, BEDDING CLASS B.

I:\CRYSTAL LANE\BENNVILLE\120058-00\WORK W\GREEN\CADD\DRAWINGS\DWG\CURRENT\120058-00\DETAILS\DWG\DTFS-01  
 Plotfile: 12/17/2012 11:56 AM By: 0728MSB  
 Copyright © 2012, By: Baxter & Woodman, Inc.  
 State of Illinois - Professional Design Firm  
 License No. - 194, 00, 121 - Expires 4-30-11

	DESIGNED - ALP	REVISED - IDOT REVIEW 12-12-12
	DRAWN - UKB	REVISED -
	CHECKED - LDH	REVISED -
	DATE - 08-09-12	REVISED -

<b>STATE OF ILLINOIS</b> <b>DEPARTMENT OF TRANSPORTATION</b>
---

<b>DETAILS</b>					
<b>FOR WATER MAIN REPLACEMENT</b>					
SCALE:	PROJECT NO: 126058 STA.	TO STA.	F.A.U. FILE:	SECTION:	COUNTY:
			35.33	10-00087-00-RS	DUPAGE
					TOTAL SHEETS: 37
					SHEET NO: 25
					CONTRACT NO. 63759
					FED. ROAD DIST. NO. 1 ILLINOIS FED. AID PROJECT