

CONTRACT BY: BAYNE & WOODMAN, INC.  
 1100 N. LAKE ST., SUITE 1000, CHICAGO, IL 60610  
 TEL: (312) 467-1000 FAX: (312) 467-1001  
 WWW: WWW.BAYNEANDWOODMAN.COM  
 12/17/2011

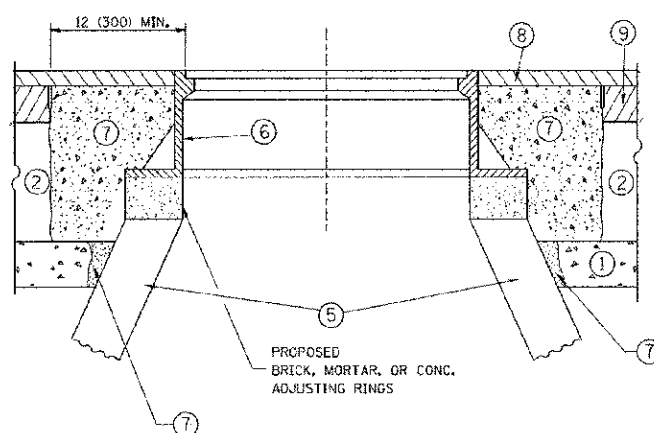
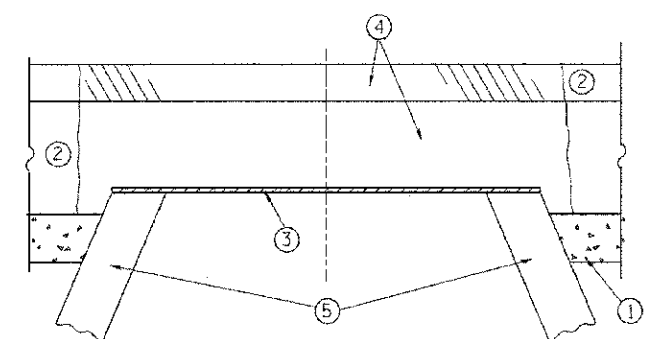

**CONSTRUCTION PROCEDURES**

- STAGE 1 (BEFORE PAVEMENT MILLING)**
- A) REMOVE A MINIMUM OF 12 (300) OF THE PAVEMENT FROM AROUND THE STRUCTURE.
  - B) REMOVE THE EXISTING FRAME AND LID FROM THE STRUCTURE.
  - C) COVER THE STRUCTURE OPENING WITH A 36 (900) DIAMETER METAL PLATE.
  - D) BACKFILL WITH CRUSHED STONE AND A MINIMUM 1 1/2 (40) THICK HMA SURFACE MIX APPROVED BY THE ENGINEER.

- STAGE 2 (AFTER PAVEMENT MILLING)**
- A) REMOVE THE HMA SURFACE MIX AND CRUSHED STONE.
  - B) INSTALL THE FRAME AND LID; ADJUST THE FRAME TO ITS FINAL SURFACE ELEVATION.
  - C) THE SURROUNDING SPACE SHALL BE FILLED WITH CLASS PP-1\* CONCRETE TO THE ELEVATION OF THE SURFACE OF THE EXISTING BASE COURSE OR THE BINDER COURSE.
- \* UNLESS OTHERWISE SPECIFIED IN THE PLANS.

THE PROCEDURE EXPLAINED ABOVE SHALL CONFORM TO THE APPLICABLE PORTIONS OF SECTIONS 353, 406, 602, AND 603 OF THE STANDARD SPECIFICATIONS EXCEPT THAT "THE CONTRACTOR SHALL ADJUST THE STRUCTURES TO THE FINISHED PAVEMENT ELEVATION NO MORE THAN 5 CALENDAR DAYS PRIOR TO PLACEMENT OF THE FINAL LIFT OF SURFACE UNLESS APPROVED BY THE ENGINEER."

**LEGEND**

- ① SUB-BASE GRANULAR MATERIAL
- ⑥ FRAME AND LID (SEE NOTES)
- ② EXISTING PAVEMENT
- ⑦ CLASS PP-1\* CONCRETE
- ③ 36 (900) DIAMETER METAL PLATE
- ⑧ PROPOSED HMA SURFACE COURSE
- ④ PROPOSED CRUSHED STONE AND HMA SURFACE MIX
- ⑨ PROPOSED HMA BINDER COURSE
- ⑤ EXISTING STRUCTURE

**LOCATION OF STRUCTURES:**

THE CONTRACTOR WILL BE REQUIRED TO KEEP A RECORD OF THE LOCATIONS OF THE BURIED STRUCTURES ACCORDING TO THE STATION AND DISTANCE LEFT OR RIGHT OF THE CENTERLINE OF PAVEMENT. UPON COMPLETION OF THE WORK, THE CONTRACTOR WILL DELIVER THE RECORD TO THE ENGINEER.

**BASIS OF PAYMENT:**

REMOVING FRAMES AND LIDS ON DRAINAGE AND UTILITY STRUCTURES IN THE PAVEMENT PRIOR TO MILLING, AND ADJUSTING TO FINAL GRADE PRIOR TO PLACING THE SURFACE COURSE, WILL BE PAID FOR AT THE CONTRACT UNIT PRICE EACH FOR "FRAMES AND LIDS TO BE ADJUSTED (SPECIAL)."

THIS WORK WILL NOT BE PAID FOR WHEN DRAINAGE AND UTILITY STRUCTURES ARE SPECIFIED FOR PAYMENT AS STRUCTURE RECONSTRUCTION.

NEW FRAMES AND LIDS, WHEN SPECIFIED, WILL BE PAID FOR SEPARATELY.

**NOTES:**

EXISTING BROKEN FRAMES AND LIDS SHALL BE REMOVED AND DISPOSED OF BY THE CONTRACTOR AND SHALL BE REPLACED AS DIRECTED BY THE ENGINEER. REPLACEMENT FRAMES AND LIDS WILL BE PAID FOR IN ACCORDANCE WITH ARTICLE 109.04 OF THE STANDARD SPECIFICATIONS UNLESS A SEPARATE PAY ITEM HAS BEEN PROVIDED.

IF THE EXISTING LIDS ARE OPEN, THE FRAME WILL BE ADJUSTED TO THE ELEVATION OF THE MILLED PAVEMENT SURFACE PRIOR TO THE MILLING OPERATION. THE FRAME WILL NOT BE REMOVED AND COVERED BY THE METAL PLATE.

CITY OF CHICAGO CASTINGS ARE THE PROPERTY OF THE CITY AND THE CONTRACTOR SHALL NOTIFY THE CITY FOR REMOVAL AND DISPOSITION OF THE CASTINGS.

THE METAL PLATE USED TO COVER THE STRUCTURE SHALL REMAIN THE PROPERTY OF THE CONTRACTOR.

WHEN STRUCTURES ARE TO BE ADJUSTED OR RECONSTRUCTED, THE LOWERING AND RAISING OF THE FRAMES AND LIDS WILL NOT BE PAID FOR SEPARATELY BUT WILL BE INCLUDED IN THE COST OF THE CORRESPONDING PAY ITEM.

**DETAILS FOR FRAMES AND LIDS ADJUSTMENT WITH MILLING**

ALL DIMENSIONS ARE IN INCHES (MILLIMETERS) UNLESS OTHERWISE SHOWN

FILE NAME = c:\p\work\p2020at\beurd\146189315\bd06.dgn	USER NAME = beurd	DESIGNED - R. SHAH DRAWN - CHECKED - DATE - 10-25-94	REVISED - R. WIEDEMAN 05-14-04 REVISED - R. BORO 01-01-07 REVISED - R. BORO 03-09-11 REVISED - R. BORO 12-06-11	<b>STATE OF ILLINOIS DEPARTMENT OF TRANSPORTATION</b>	<b>DETAILS FOR FRAMES AND LIDS ADJUSTMENT WITH MILLING</b>	F.A.U. RT#: 3533	SECTION: 10-00087-00-RS	COUNTY: DUPAGE	TOTAL SHEETS: 37	SHEET NO.: 27
SCALE: NONE   SHEET NO. 1 OF 1 SHEETS   STA. TO STA.						<b>BD600-03 (RD-8)</b>   CONTRACT NO. 63759   FED. ROAD DIST. NO. 1   ILLINOIS   FED. AID PROJECT				