

EXISTING TYPICAL SECTION
STA. 12+00.00 TO STA. 14+19.70
(LOOKING EAST)

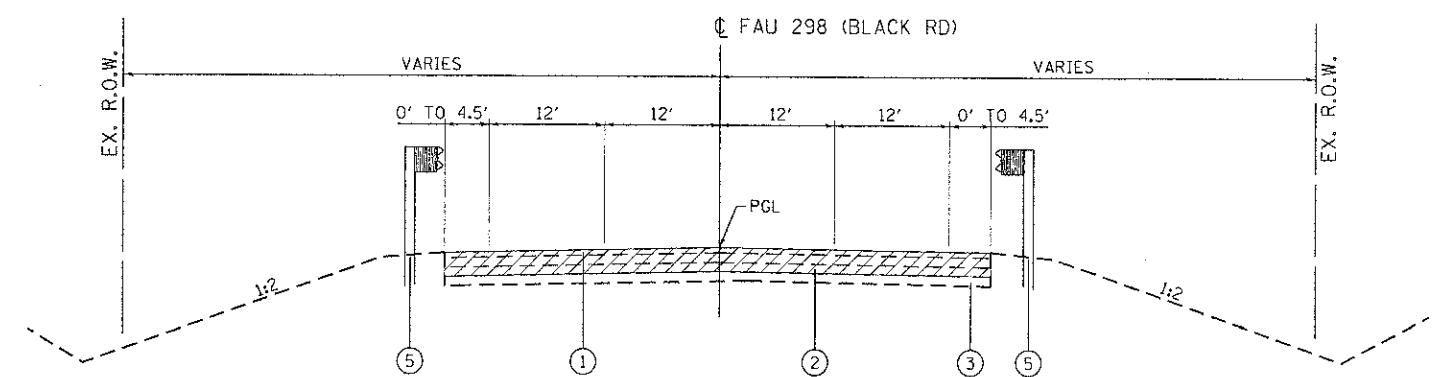

EXISTING TYPICAL SECTION
STA. 17+21.62 TO STA. 18+72.09
(LOOKING EAST)

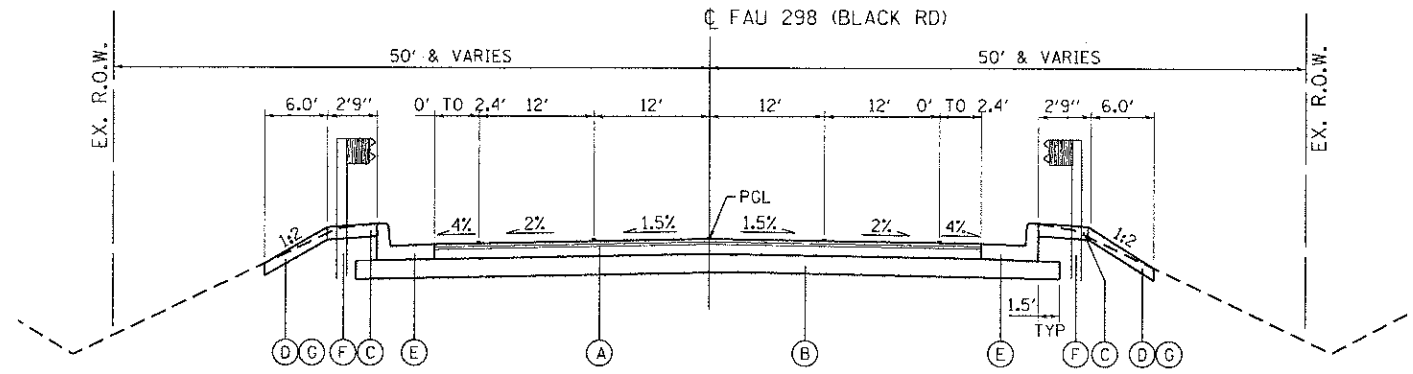

PROPOSED TYPICAL SECTION
STA. 12+00.00 TO STA. 14+05.08
(LOOKING EAST)

• BRIDGE APPROACH PAVEMENT CONNECTOR (FLEXIBLE) STA. 14+05.08 TO STA. 14+11.08 (SEE IDOT STANDARD DETAIL 420401-09)

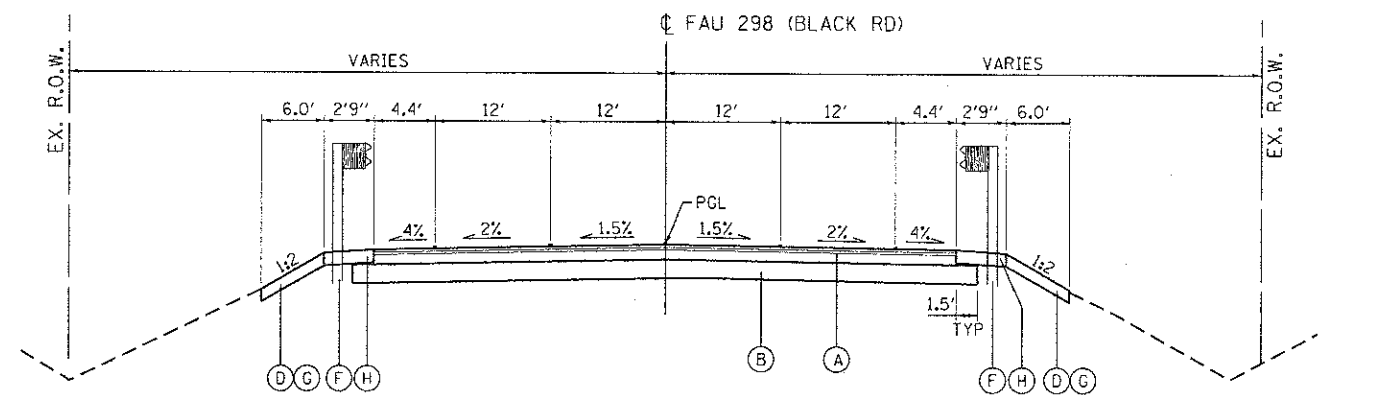

PROPOSED TYPICAL SECTION
STA. 17+37.41 TO STA. 18+72.09
(LOOKING EAST)

• BRIDGE APPROACH PAVEMENT CONNECTOR (FLEXIBLE) STA. 17+31.41 TO STA. 17+37.41 (SEE IDOT STANDARD DETAIL 420401-09)

EXISTING CONDITIONS

- ① HOT-MIX ASPHALT SURFACE COURSE 1 1/2" •
HOT-MIX ASPHALT BINDER COURSE 1 1/2" •
- ② HOT-MIX ASPHALT BASE COURSE 8" •
- ③ AGGREGATE SUB-BASE 4" ••
- ④ COMBINATION CONCRETE CURB AND GUTTER
- ⑤ GUARDRAIL

- REMOVAL PAID AS PAVEMENT REMOVAL
- REMOVAL PAID AS EARTH EXCAVATION

- PAVEMENT REMOVAL
- COMBINATION CURB AND GUTTER REMOVAL

PROPOSED IMPROVEMENTS

- Ⓐ HOT-MIX ASPHALT PAVEMENT, (FULL-DEPTH), 13 3/4" (2" SURFACE, 2 1/4" BINDER, 9 1/2" BASE)
- Ⓑ AGGREGATE SUBGRADE IMPROVEMENT, 12"
- Ⓒ HOT-MIX ASPHALT SHOULDERS, 6"
- Ⓓ TOPSOIL, FURNISH AND PLACE 4" AND SEEDING PER LANDSCAPING PLAN
- Ⓔ COMBINATION CONCRETE CURB AND GUTTER TYPE B-6.24
- Ⓕ STEEL PLATE BEAM GUARD RAIL, TYPE A, 9 FOOT POSTS
- Ⓖ EARTH EXCAVATION
- Ⓗ AGGREGATE SHOULDERS, TYPE B 6"

HOT-MIX ASPHALT MIXTURE REQUIREMENTS

OPERATION	MIXTURE TYPE	AIR VOIDS @ Ndes
ROADWAY RECONSTRUCTION	HOT-MIX ASPHALT PAVEMENT, (FULL DEPTH), 13 3/4"	4% @ 70 Gyr. 4% @ 70 Gyr. 4% @ 70 Gyr.
	HOT-MIX ASPHALT SURFACE COURSE, MIX "D", N70 (IL-9.5mm), 2"	
	HOT-MIX ASPHALT BINDER COURSE, IL-19.0, N70, 2 1/4"	
BRIDGE APPROACH PAVEMENT CONNECTOR (FLEXIBLE)	HOT-MIX ASPHALT SURFACE COURSE, MIX "D", N70 (IL-9.5mm), 2"	4% @ 70 Gyr. 4% @ 70 Gyr. 4% @ 70 Gyr.
	HOT-MIX ASPHALT BINDER COURSE, IL-19.0, N70, 2 1/4"	
	HOT-MIX ASPHALT BASE COURSE, (HMA BINDER IL-19MM) 9 1/2" TO 10 3/4" (3 LIFTS)	
SHOULDER STABILIZATION	HOT-MIX ASPHALT SHOULDERS, 6" HOT-MIX ASPHALT SHOULDER, (HMA BINDER IL-19MM), 6" (2 LIFT)	4% @ 50 Gyr.

NOTE:

THE UNIT WEIGHT USED TO CALCULATE ALL HOT-MIX ASPHALT SURFACE MIXTURE IS 112 LBS/SQYD/IN. THE "AC TYPE" FOR POLYMERIZED HMA MIXES SHALL BE "SBS/SBR PG 76-22" AND FOR NON-POLYMERIZED HMA THE "AC TYPE" SHALL BE "PG 64-22" UNLESS MODIFIED BY DISTRICT ONE SPECIAL PROVISIONS. FOR USE OF RECYCLED MATERIALS SEE SPECIAL PROVISIONS.

FILE NAME: N:\P\A\0023\005\020\Geog\T\p\sect\Spec\ions\031830_00-Typical\01.dwg