

WITNESS MARKER FOR PERMANENT SURVEY MARKERS, TYPE II

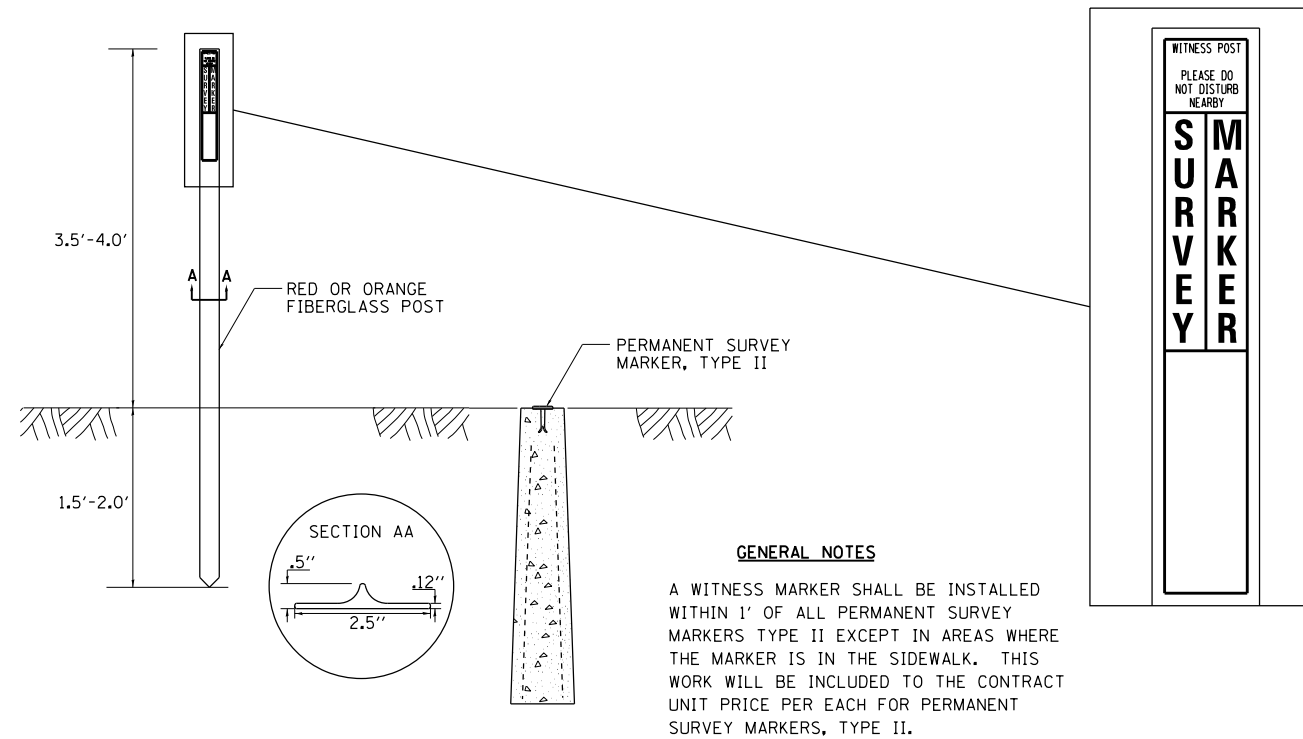

PERMANENT SURVEY MARKERS, TYPE II

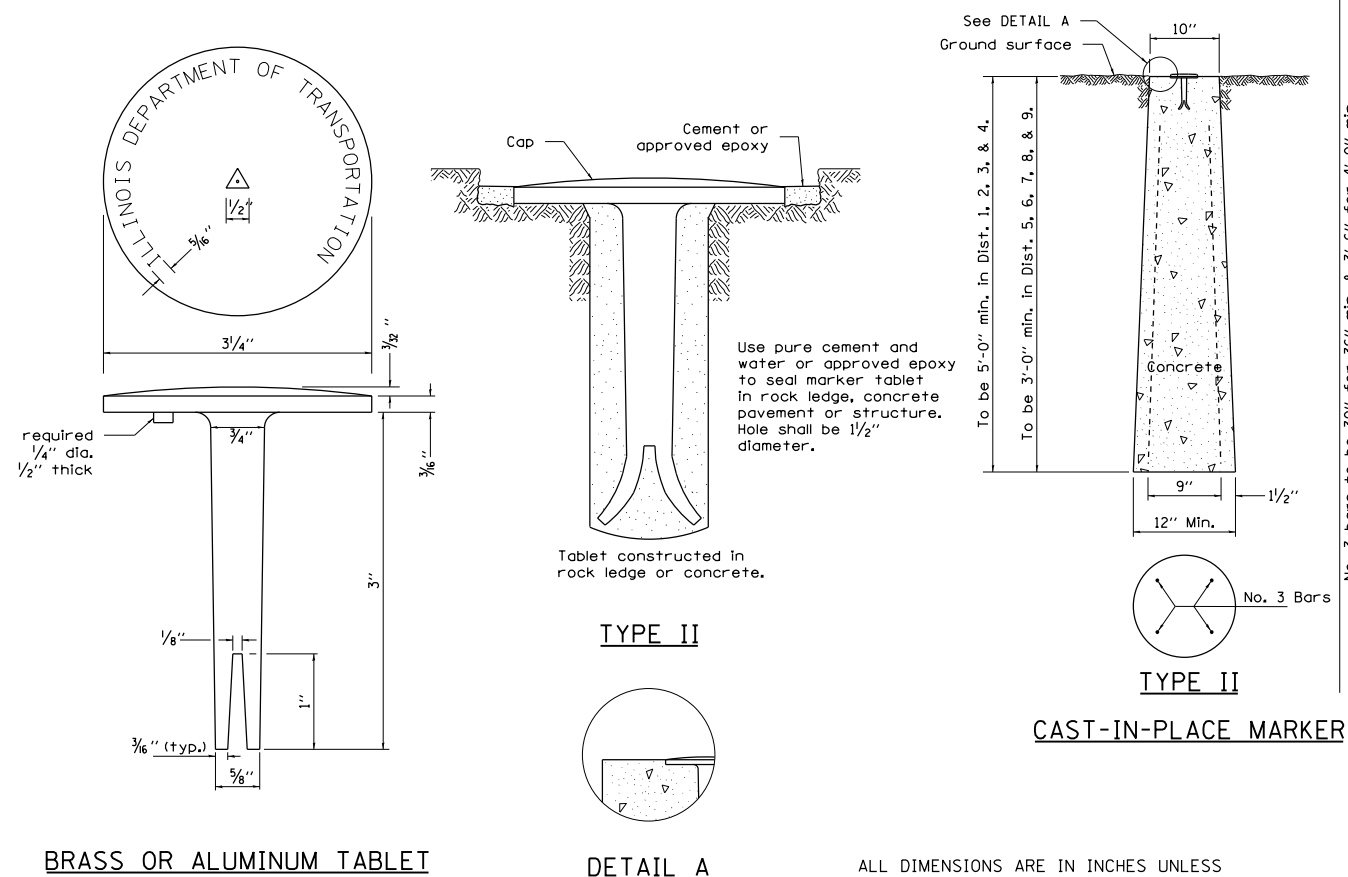

AUTOMATIC FLAP GATE

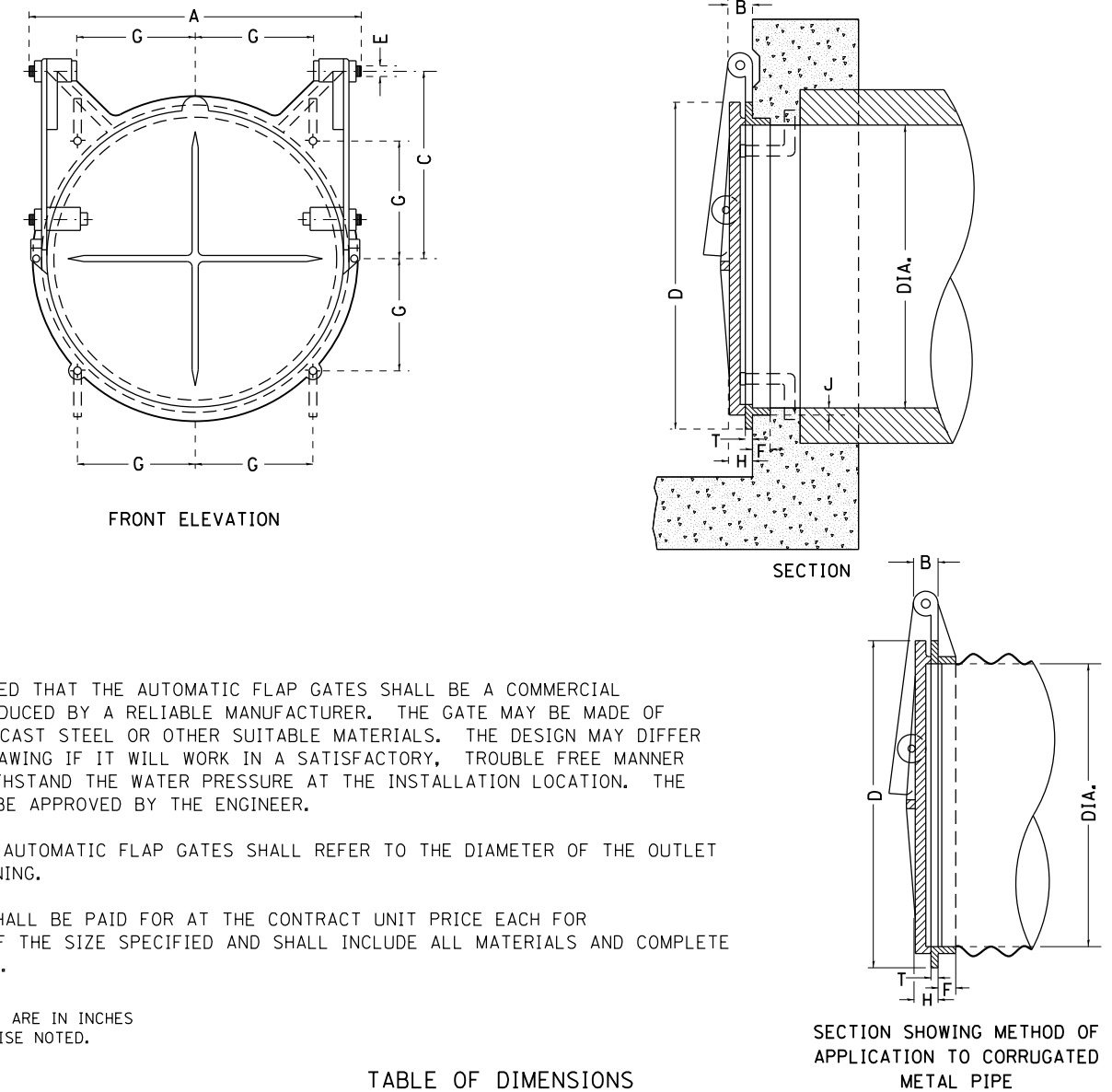

IT IS INTENDED THAT THE AUTOMATIC FLAP GATES SHALL BE A COMMERCIAL PRODUCT PRODUCED BY A RELIABLE MANUFACTURER. THE GATE MAY BE MADE OF CAST IRON, CAST STEEL OR OTHER SUITABLE MATERIALS. THE DESIGN MAY DIFFER FROM THE DRAWING IF IT WILL WORK IN A SATISFACTORY, TROUBLE FREE MANNER AND WILL WITHSTAND THE WATER PRESSURE AT THE INSTALLATION LOCATION. THE GATE SHALL BE APPROVED BY THE ENGINEER.

THE SIZE OF AUTOMATIC FLAP GATES SHALL REFER TO THE DIAMETER OF THE OUTLET PIPE OR OPENING.

THIS WORK SHALL BE PAID FOR AT THE CONTRACT UNIT PRICE EACH FOR FLAP GATE OF THE SIZE SPECIFIED AND SHALL INCLUDE ALL MATERIALS AND COMPLETE INSTALLATION.

ALL DIMENSIONS ARE IN INCHES UNLESS OTHERWISE NOTED.

TABLE OF DIMENSIONS

DIAM	A	B	C	D	E	F	G	H	J	T
8	10 3/4	1 3/8	5 11/16	10	1/2	1 1/8	3 9/16	1 1/4	3/8	3/8
10	12 3/4	1 3/8	7 1/8	12 1/4	1/2	1 1/8	4 3/8	1 1/2	1/2	7/16
12	14 3/4	1 3/8	8 1/2	14 1/2	1/2	1 1/8	5 1/8	1 1/2	1/2	1/2
14	17 1/4	1 3/8	9 5/8	16 3/4	1/2	1 1/4	5 15/16	1 1/2	1/2	9/16
15	17 3/4	1 3/8	10 5/8	17 3/4	1/2	1 1/4	6 1/4	1 1/2	1/2	9/16
16	19 1/4	1 3/8	11 1/4	18 3/4	1/2	1 1/4	6 5/8	1 1/2	1/2	9/16
18	22 1/4	2	12 5/8	21	3/4	1 9/16	7 7/16	1 3/4	9/16	9/16
20	24 3/4	2	14 1/8	23 3/4	3/4	1 3/8	8 1/4	1 3/4	5/8	5/8
21	25 1/4	2	14 7/8	24 1/4	3/4	1 3/8	8 9/16	1 3/4	5/8	5/8
24	28 1/4	2	17	27 1/2	3/4	1 1/2	9 3/4	1 3/4	5/8	5/8
30	35 1/4	2 1/2	20 1/2	34	1	1 9/16	12	2	1 1/16	5/8
36	41 1/2	2 1/2	25	40 7/8	1	2 1/16	14 1/16	2 1/4	1 1/8	11/16
42	47 1/2	2 1/2	29 3/4	47	1	2 5/16	16 5/8	2 1/4	1 1/8	3/4
48	53 1/2	2 1/2	34	54	1	2 3/4	19 1/16	2 1/4	1 3/8	3/4
54	60 3/4	2 1/2	38	62 1/4	1 1/4	2 3/4	22	3	1 1/2	7/8
60	67	2 1/2	42	68 1/2	1 1/4	2 3/4	24 1/4	3	1 1/2	15/16
66	73 3/8	2 1/2	47	75	1 1/4	2 7/8	26 1/2	3	1 1/2	1
72	79	2 1/2	51	82	1 1/4	3	29	3	1 1/2	1
78	86	2 1/2	55 1/4	88 3/4	1 1/4	3 1/2	31 3/8	3	1 5/8	1 1/8
84	92 1/2	3 1/2	59 1/2	95 1/2	1 1/2	3 1/2	33 3/4	3	1 3/4	1 1/4

REVISED - 10-14-11

REVISED - 10-14-11

REGION 2 / DISTRICT 2 STANDARD

F.A.U. R.T.E.	SECTION	COUNTY	TOTAL SHEETS	SHEET NO.
5789	40BR	ROCK ISLAND	225	155
CONTRACT NO.			64341	

SCALE: 40,0000' / 1" SHEET NO. OF SHEETS STA. TO STA.

FED. ROAD DIST. NO. ILLINOIS FED. AID PROJECT