

TYPICAL EXPRESSWAY SECTION (FAP 302)

STA. 1048+00.00 TO STA. 1262+75.00

EXISTING LEGEND

- ① EXISTING LIME MODIFIED SOIL, 11 3/4"
- ② EXISTING BITUMINOUS CONCRETE PAVEMENT (FULL-DEPTH), 13 1/4"
- ③ EXISTING PIPE UNDERDRAINS, 4"
- ④ EXISTING SUB-BASE GRANULAR MATERIAL TYPE C, 5 1/2"
- ⑤ EXISTING BITUMINOUS SHOULDERS, 7 3/4", WITH RUMBLE STRIPS
- ⑥ EXISTING AGGREGATE SHOULDERS, TYPE B
- ⑦ EXISTING EARTH SHOULDERS
- ⑧ EXISTING BITUMINOUS CONCRETE PAVEMENT (FULL-DEPTH), 11 3/4"

PROPOSED LEGEND

- ⑬ PROPOSED PAVED SHOULDER REMOVAL
- ⑭ PROPOSED SUBBASE GRANULAR MATERIAL, TYPE A, 8"
- ⑮ PROPOSED HOT-MIX ASPHALT SURFACE REMOVAL, 1 1/2"
- ⑯ PROPOSED HOT-MIX ASPHALT BASE COURSE, 11 3/4"
- ⑰ PROPOSED HOT-MIX ASPHALT SURFACE COURSE, MIX "C", N50, 1 1/2"
- ⑱ PROPOSED AGGREGATE SHOULDERS, TYPE B
- ⑲ PROPOSED EARTH SHOULDERS

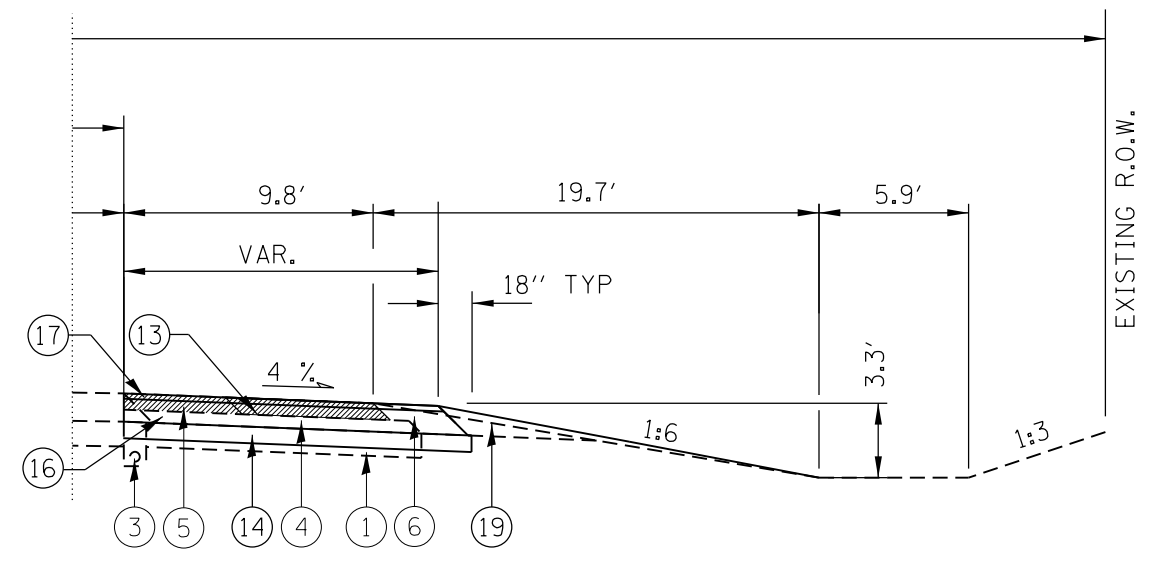

DETAIL A

STA. 1048+00.00 TO STA. 1262+75.00

FILE NAME = c:\pwwork\pwwork\sparks\10325326\0672\FB7-sh-typical.dgn	USER NAME = sparks	DESIGNED -	REVISED -	STATE OF ILLINOIS DEPARTMENT OF TRANSPORTATION	TYPICAL SECTIONS			F.A.P. RTE. = 302	SECTION = (34-1,34-2) N	COUNTY = HANCOCK	TOTAL SHEETS = 22	SHEET NO. = 8
	PLOT SCALE = 40.0000' / in.	CHECKED -	REVISED -					CONTRACT NO. 72F87				
Default	PLOT DATE = Feb-13-2013 08:46:28AM	DATE -	REVISED -	SCALE: SHEET OF SHEETS STA. TO STA.			ILLINOIS FED. AID PROJECT					