

TOP AND BOTTOM FLANGE SPLICE

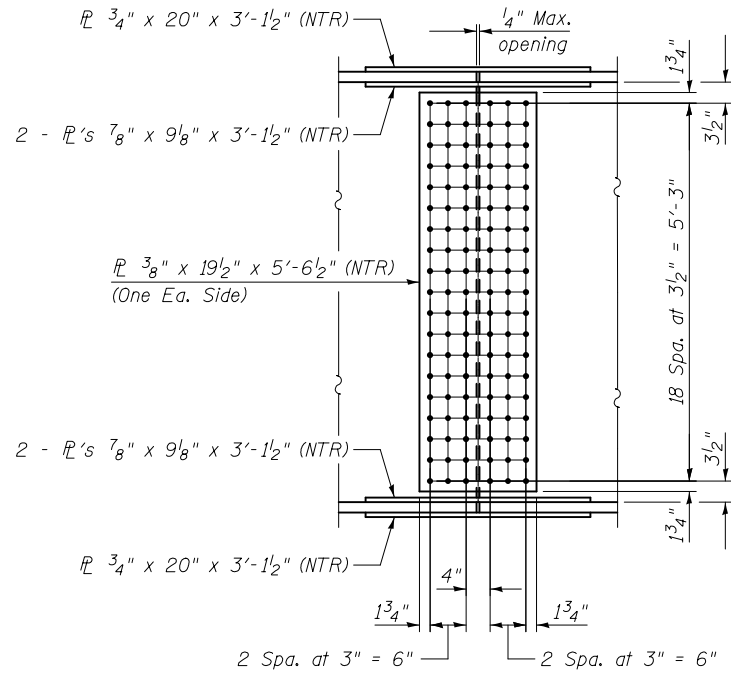

WEB SPLICE

FIELD SPLICE DETAIL - UNIT 1
(Field Splice 1, 2, 3, 4, 5 and 6)

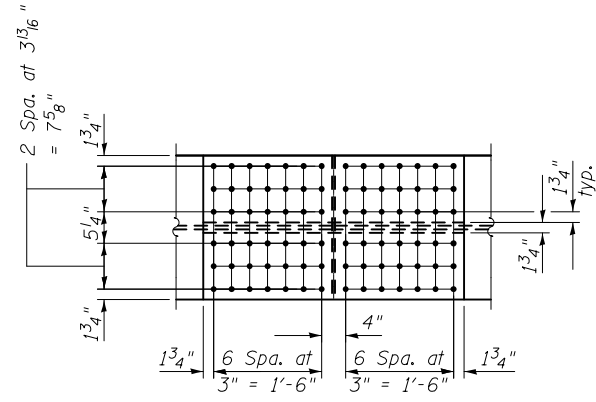

TOP AND BOTTOM FLANGE SPLICE

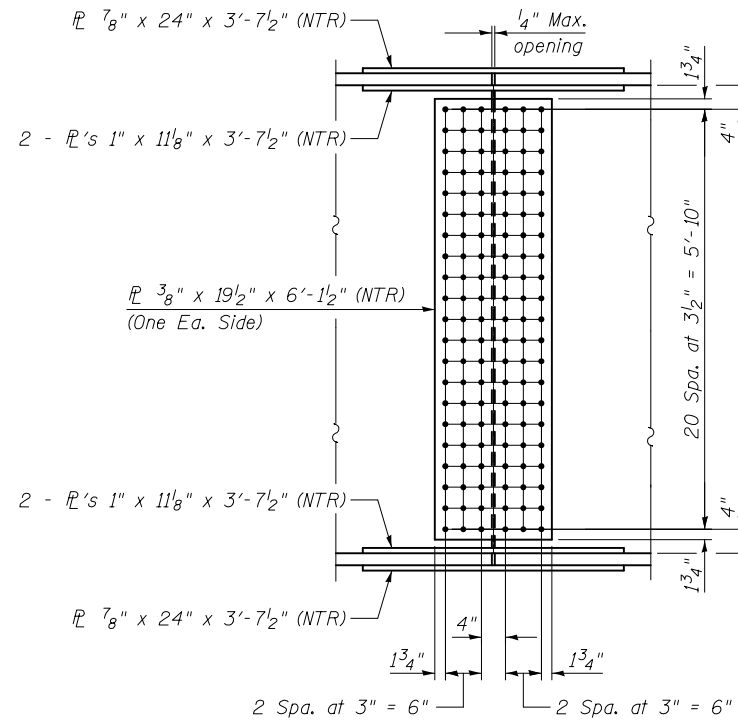

WEB SPLICE

FIELD SPLICE DETAIL - UNIT 2
(Field Splice 7 and 8)

***TOP OF WEB ELEVATIONS**

Girder No.	Unit 1										Unit 2					
	Q. Brg. N. Abut.	Q. Field Splice 1	Q. Brg. Pier 1	Q. Field Splice 2	Q. Field Splice 3	Q. Brg. Pier 2	Q. Field Splice 4	Q. Field Splice 5	Q. Brg. Pier 3	Q. Field Splice 6	Q. N. Brg. Pier 4	Q. S. Brg. Pier 4	Q. Field Splice 7	Q. Brg. Pier 5	Q. Field Splice 8	Q. Brg. S. Abut.
1	434.08	435.01	435.30	435.59	436.38	436.69	436.99	437.71	437.77	437.83	437.18	437.14	436.59	436.15	435.95	435.15
2	434.20	435.13	435.42	435.71	436.50	436.81	437.12	437.83	437.89	437.95	437.30	437.27	436.72	436.27	436.07	435.27
3	434.30	435.23	435.52	435.82	436.60	436.91	437.22	437.93	437.99	438.05	437.40	437.37	436.82	436.37	436.18	435.37
4	434.30	435.23	435.52	435.82	436.60	436.91	437.22	437.93	437.99	438.05	437.40	437.37	436.82	436.37	436.18	435.37
5	434.20	435.13	435.42	435.71	436.50	436.81	437.12	437.83	437.89	437.95	437.30	437.27	436.72	436.27	436.07	435.27
6	434.08	435.01	435.30	435.59	436.38	436.69	436.99	437.71	437.77	437.83	437.18	437.14	436.59	436.15	435.95	435.15

* For fabrication only.

Notes:
Load carrying components designated "NTR" shall conform to the Impact Testing Requirement, Zone 2.
All splice plates shall be AASHTO M270 Grade 50 steel.



USER NAME =	DESIGNED - RLM	REVISED
	CHECKED - JTH	REVISED
PLOT SCALE =	DRAWN - PRC	REVISED
PLOT DATE = 2/1/2013	CHECKED - RLM	REVISED

STATE OF ILLINOIS
DEPARTMENT OF TRANSPORTATION

MISCELLANEOUS STEEL DETAILS
STRUCTURE NO. 014-0033

SHEET NO. 32 OF 61 SHEETS

F.A.P. RTE.	SECTION	COUNTY	TOTAL SHEETS	SHEET NO.
42	1-1BR-2	CLINTON	159	101
CONTRACT NO. 76479				
ILLINOIS FED. AID PROJECT				