

GENERAL NOTES

All structural steel shall conform to AASHTO Classification M-270 Gr. 50, unless otherwise noted.
 Reinforcement bars designated (E) shall be epoxy coated.
 Plan dimensions and details relative to existing plans are subject to nominal construction variations. The Contractor shall field verify existing dimensions and details affecting new construction and make necessary approved adjustments prior to construction or ordering of materials. Such variations shall not be cause for additional compensation for a change in scope of the work, however, the Contractor will be paid for the quantity actually furnished at the unit price bid for the work.
 Modular Expansion Joints shall be assembled in their final relative position with the ends in place for shop inspection and acceptance.
 Existing structural steel that will be in contact with new structural steel shall be cleaned and painted prior to erection as required by the Special Provision "Cleaning and Painting Contact Surface Areas of Existing Steel Structures".
 Joint openings shall be adjusted according to Article 520.04 of the Standard Specifications when the deck is poured at an ambient temperature other than 50° F.
 Cost of removal and re-installation of all members necessary to complete the work as detailed on the plans and as specified in the Special Provisions shall be included with Furnishing and Erecting Structural Steel.
 The Inorganic Zinc Rich Primer / Acrylic / Acrylic Paint System shall be used for shop and field painting of new structural steel except where otherwise noted. The color of the final finish coat shall be Gray, Munsell No. 5B 7/1.
 The existing structural steel coating contains lead. The Contractor shall take appropriate precautions to deal with the presence of lead on this project.
 The deck surface shall have its final finish tined according to Article 420.09(e)(1) of the Standard Specifications. Cost included with Concrete Superstructure.
 Prior to pouring the new concrete deck, all heavy or loose rust, loose mill scale, and other loose or potentially detrimental foreign material shall be removed from the surfaces in contact with concrete. Tightly adhered paint may remain unless otherwise noted. Removal shall be accomplished by methods that will not damage the steel and the cost will be included in the pay item covering removal of the existing concrete.

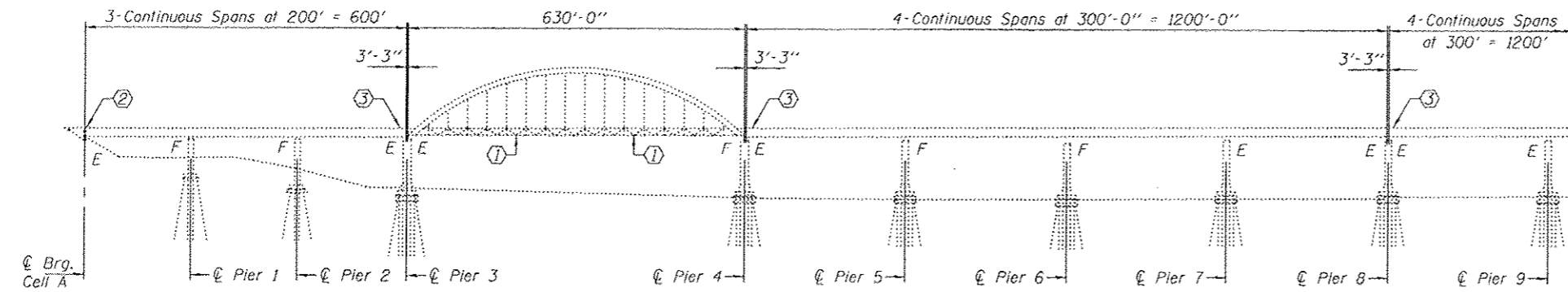

PARTIAL ELEVATION - 1

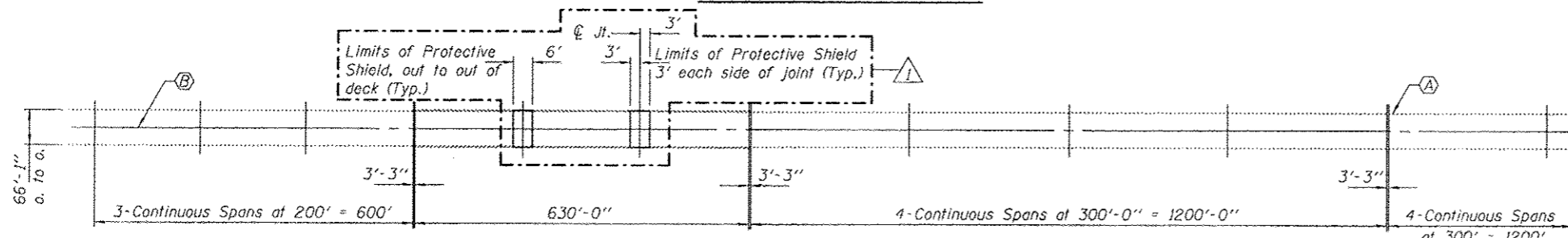

PARTIAL PLAN - 1

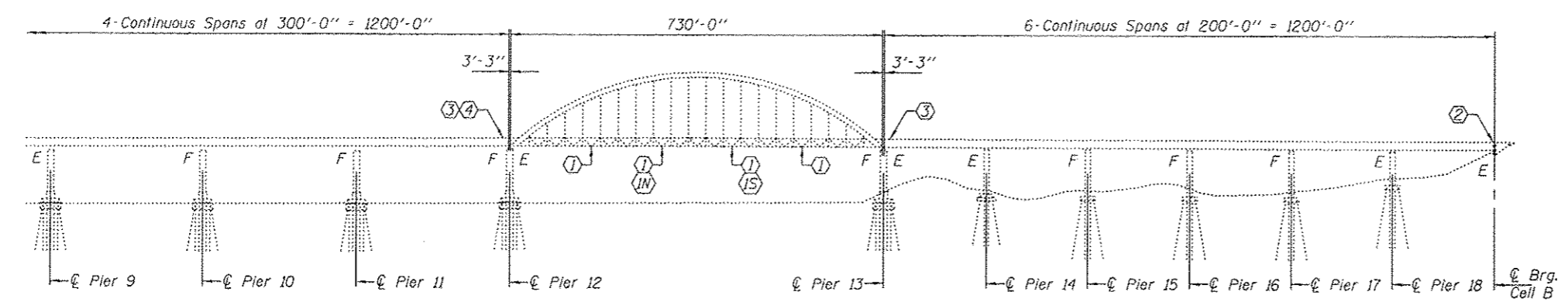

PARTIAL ELEVATION - 2

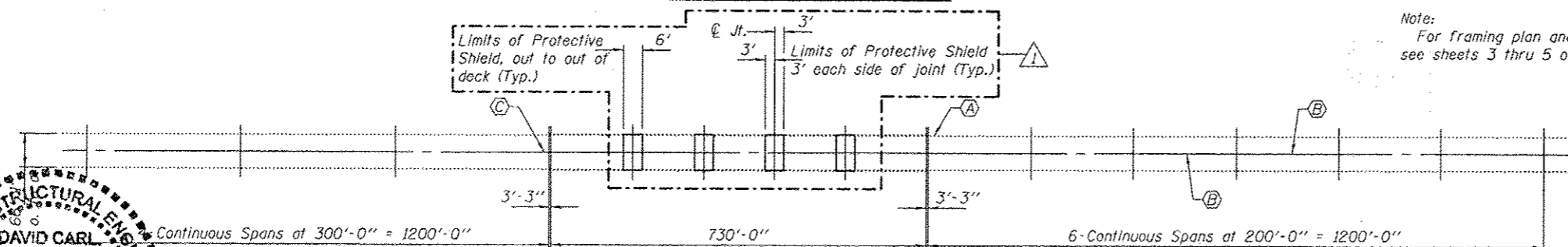

PARTIAL PLAN - 2

SCOPE OF WORK

- ① - Remove & Replace existing 2 1/2" PJS Relief Joints with Preformed Joint Strip Seal.
- ② - Remove & Replace additional 1'-0" of top section of each parapet wall at North end of Joint.
- ③ - Remove & Replace additional 1'-0" of top section of each parapet wall at South end of Joint.
- ④ - Remove & Replace existing Finger Plate Joints with Modular Expansion Joints.
- ⑤ - Remove & Replace existing Elastomeric Trough.
- ⑥ - Grind flush high side of existing fingers at Finger Plate Joint, Eastbound / Southbound Lanes.
- ⑦ - Structural Repair of Concrete Depth ≤ 5 inches. See Sheet 13 of 15 for details.

Note:
For framing plan and repair locations see sheets 3 thru 5 of 15.

TOTAL BILL OF MATERIAL

Item	Unit	Total
Structural Steel Removal	Pound	23,410
Furnishing & Erecting Structural Steel	Pound	14,670
Concrete Removal	Cu. Yd.	143.0
Concrete Superstructure	Cu. Yd.	148.3
Structural Repair of Concrete Depth ≤ 5 inches	Sq. Ft.	135
Bar Splicers	Each	288
Reinforcement Bars, Epoxy Coated	Pound	19,340
Preformed Joint Strip Seal	Foot	378
Fabric Reinforced Elastomeric Trough	Foot	330
Replace Handrail Support	Each	33
Modular Expansion Joint, 6"	Foot	66
Modular Expansion Joint, 9"	Foot	66
HMA Surface Removal, 1 1/2"	Sq. Yd.	36,600
Polymerized HMA Surface Course, Mix "E", N90	Ton	3074
Stiffener Intersection Modification	Each	2
Mechanical Splicers	Each	288
Protective Shield	Sq. Yd.	264

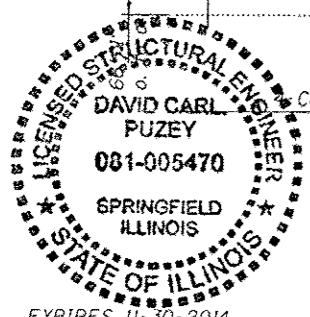

DESIGNED: *Timothy A. Armbrrecht*
 CHECKED: *Stephen M. Ryan*
 DRAWN: Kyle M. Steffen
 EXAMINED: *Timothy A. Armbrrecht*
 PASSED: *David Carl Puzey*
 DATE: MARCH 14, 2013
 REVISED: 04/15/2013 ATH

STATE OF ILLINOIS
 DEPARTMENT OF TRANSPORTATION

GENERAL PLAN & ELEVATION
 F.A.I. 24 OVER THE OHIO RIVER
 SN 064-0035
 SHEET NO. 1 OF 15 SHEETS

F.A.I. RTE.	SECTION	COUNTY	TOTAL SHEETS	SHEET NO.
24	BSMART 2013-1	MASSAC	23	9
CONTRACT NO. 78293			ILLINOIS FED. AID PROJECT	