

05A

Letting April 26, 2019

Notice to Bidders, Specifications and Proposal



**Illinois Department
of Transportation**

Springfield, Illinois 62764

**Contract No. RA017
Rantoul National Aviation Center
Rantoul, Illinois
Champaign County
Illinois Project No. TIP-4687
SBG Project No. 3-17-SBGP-139/144**



1. **TIME AND PLACE OF OPENING BIDS.** Electronic bids are to be submitted to the electronic bidding system (iCX-Integrated Contractors Exchange). All bids must be submitted to the iCX system prior to 10:00 a.m. on April 26, 2019, at which time the bids will be publicly opened from the iCX SecureVault.
2. **DESCRIPTION OF WORK.** The proposed improvement is identified and advertised for bids in the Invitation for Bids as:

**Contract No. RA017
Rantoul National Aviation Center
Rantoul, Illinois
Champaign County
Illinois Project No. TIP-4687
SBG Project No. 3-17-SBGP-139/144**

Phase 3: Construct Wildlife Deterrent Fence

For engineering information, please contact Stephen J. McLaughlin, P.E. of Burns & McDonnell Engineering Co. at 312.465.7715.

3. INSTRUCTIONS TO BIDDERS.

- (a) This Notice, the invitation for bids, proposal and letter of award shall, together with all other documents in accordance with Article 10-18 of the Illinois Standard Specifications for Construction of Airports, become part of the contract. Bidders are cautioned to read and examine carefully all documents, to make all required inspections, and to inquire or seek explanation of the same prior to submission of a bid.
- (b) State law, and, if the work is to be paid wholly or in part with Federal-aid funds, Federal law requires the bidder to make various certifications as a part of the proposal and contract. By execution and submission of the proposal, the bidder makes the certification contained therein. A false or fraudulent certification shall, in addition to all other remedies provided by law, be a breach of contract and may result in termination of the contract.

4. **AWARD CRITERIA AND REJECTION OF BIDS.** This contract will be awarded within 60 calendar days to the lowest responsive and responsible bidder considering conformity with the terms and conditions established by the Department in the rules, Invitation for Bids and contract documents. The issuance of plans and proposal forms for bidding based upon a prequalification rating shall not be the sole determinant of responsibility. The Department reserves the right to determine responsibility at the time of award, to reject any or all proposals, to readvertise the proposed improvement, and to waive technicalities.

5. **PRE-BID CONFERENCE.** N/A

6. **DISADVANTAGED BUSINESS POLICY.** The DBE goal for this contract is 8.0%.

7. **SPECIFICATIONS AND DRAWINGS.** The work shall be done in accordance with the Illinois Standard Specifications for Construction of Airports, the Special Provisions dated March 1, 2019, and the Construction Plans dated March 1, 2019 as approved by the Illinois Department of Transportation, Division of Aeronautics.

- 8. BIDDING REQUIREMENTS AND BASIS OF AWARD.** When alternates are included in the proposal, the following shall apply:
- a. Additive Alternates
 - (1) Bidders must submit a bid for the Base Bid and for all Additive Alternates.
 - (2) Award of this contract will be made to the lowest responsible qualified bidder computed as follows:

The lowest aggregate amount of (i) the Base Bid plus (ii) any Additive Alternate(s) which the Department elects to award.

The Department may elect not to award any Additive Alternates. In that case, award will be to the lowest responsible qualified bidder of the Base Bid.
 - b. Optional Alternates
 - (1) Bidders must submit a bid for the Base Bid and for either Alternate A or Alternate B or for both Alternate A and Alternate B.
 - (2) Award of this contract will be made to the lowest responsible qualified bidder computed as follows:

The lower of the aggregate of either (i) the Base Bid plus Alternate A or (ii) the Base Bid plus Alternate B.
- 9. CONTRACT TIME.** The Contractor shall complete all work within the specified contract time. Any calendar day extension beyond the specified contract time must be fully justified, requested by the Contractor in writing, and approved by the Engineer, or be subject to liquidated damages.
- The contract time for this contract is 40 calendar days.
- 10. INDEPENDENT WEIGHT CHECKS.** The Department reserves the right to conduct random unannounced independent weight checks on any delivery for bituminous, aggregate or other pay item for which the method of measurement for payment is based on weight. The weight checks will be accomplished by selecting, at random, a loaded truck and obtaining a loaded and empty weight on an independent scale. In addition, the department may perform random weight checks by obtaining loaded and empty truck weights on portable scales operated by department personnel.
- 11. MATERIAL COST ADJUSTMENTS.** Federal Aviation Administration rules prohibit the use of escalation clauses for materials. Therefore, the Illinois Department of Transportation, Division of Aeronautics cannot offer any material cost adjustment provisions for projects that utilize Federal Funds.
- 12. GOOD FAITH COMPLIANCE.** The Illinois Department of Transportation has made a good faith effort to include all statements, requirements, and other language required by federal and state law and by various offices within federal and state governments whether that language is required by law or not. If anything of this nature has been left out or if additional language etc. is later required, the bidder/contractor shall cooperate fully with the Department to modify the contract or bid documents to correct the deficiency. If the change results in increased operational costs, the Department shall reimburse the contractor for such costs as it may find to be reasonable.

By Order of the
Illinois Department of Transportation

Omer Osman,
Secretary



Sponsor _____ Item No. _____

IL Proj. No. _____ SBG Pr. No. _____ Letting Date _____

KNOW ALL MEN BY THESE PRESENTS, That We _____

as PRINCIPAL, and _____

_____ as SURETY, are held jointly, severally and firmly bound unto the SPONSOR identified above, in the penal sum of 5 percent of the total bid price, or for the amount specified in Section 6, Proposal Guaranty of the Proposal Document, whichever is the lesser sum, well and truly to be paid unto said SPONSOR, for the payment of which we bind ourselves, our heirs, executors, administrators, successors and assigns.

THE CONDITION OF THE FOREGOING OBLIGATION IS SUCH, that whereas, the PRINCIPAL has submitted a bid proposal to the SPONSOR through its AGENT, the State of Illinois, Department of Transportation, Division of Aeronautics, for the improvement designated by the Transportation Bulletin Item Number and Letting Date indicated above.

NOW, THEREFORE, if the SPONSOR through its AGENT shall accept the bid proposal of the PRINCIPAL; and if the PRINCIPAL shall, and as specified in the bidding and contract documents, submit a DBE Utilization Plan that is accepted and approved by the AGENT; and if, after the award by AGENT on behalf of SPONSOR, the PRINCIPAL shall enter into a contract in accordance with the terms of the bidding and contract documents, including evidence of the required insurance coverages and providing such bond as specified with good and sufficient surety for the faithful performance of such contract and for the prompt payment of labor and material furnished in the prosecution thereof; or if, in the event of the failure of the PRINCIPAL to make the required DBE submission or to enter into such contract and to give the specified bond, the PRINCIPAL pays to the SPONSOR the difference not to exceed the penalty hereof between the amount specified in the bid proposal and such larger amount for which the SPONSOR may contract with another party to perform the work covered by said bid proposal, then this obligation shall be null and void. otherwise, it shall remain in full force and effect.

IN THE EVENT the SPONSOR acting through its AGENT determines the PRINCIPAL has failed to comply with any requirement as set forth in the preceding paragraph, then SURETY shall pay the penal sum to the SPONSOR within fifteen (15) days of written demand therefor. If SURETY does not make full payment within such period of time, the AGENT may bring an action to collect the amount owed. SURETY is liable to the SPONSOR and to the AGENT for all its expenses, including attorney's fees, incurred in any litigation in which SPONSOR or AGENT prevail either in whole or in part.

In TESTIMONY WHEREOF, the said PRINCIPAL and the said SURETY have caused this instrument to be signed by their respective officers _____ day of _____ A.D., _____ .

PRINCIPAL

(Company Name)

SURETY

(Company Name)

By _____
(Signature & Title)

By: _____
(Signature of Attorney-in-Fact)

Notary Certification for Principal and Surety

STATE OF ILLINOIS,
County of _____

I, _____, a Notary Public in and for said County, do hereby certify that _____ and _____
(Insert names of individuals signing on behalf of PRINCIPAL & SURETY)

who are each personally known to me to be the same persons whose names are subscribed to the foregoing instrument on behalf of PRINCIPAL and SURETY, appeared before me this day in person and acknowledged respectively, that they signed and delivered said instrument as their free and voluntary act for the uses and purposes therein set forth.

Given under my hand and notarial seal this _____ day of _____ A.D. _____

My commission expires _____

Notary Public

In lieu of completing the above section of the Proposal Bid Form, the Principal may file an Electronic Bid Bond. By signing the proposal and marking the check box next to the Signature and Title line below, the Principal is ensuring the identified electronic bid bond has been executed and the Principal and Surety are firmly bound unto the SPONSOR through its AGENT under the conditions of the bid bond as shown above.

Electronic Bid Bond ID# _____ Company / Bidder Name _____ Signature and Title _____

ILLINOIS DEPARTMENT OF TRANSPORTATION
DIVISION OF AERONAUTICS

REQUIRED CONTRACT PROVISIONS FOR STATE FUNDED AIRPORT CONSTRUCTION PROJECTS

The following provisions are State of Illinois requirements and are in addition to the REQUIRED CONTRACT PROVISIONS FOR AIRPORT IMPROVEMENT PROGRAM AND FOR OBLIGATED SPONSORS

DISADVANTAGED BUSINESS POLICY

NOTICE: This proposal contains the special provision entitled "Disadvantaged Business Participation." Inclusion of this Special Provision in this contract satisfies the obligations of the Department of Transportation under federal law as implemented by 49 CFR 23 and under the Illinois "Minority and Female Business Enterprise Act."

POLICY: It is public policy that the businesses defined in 49 CFR Part 23 shall have the maximum opportunity to participate in the performance of contracts financed in whole or in part with State or Federal funds. Consequently, the requirements of 49 CFR Part 23 apply to this contract.

OBLIGATION: The Contractor agrees to ensure that the businesses defined in 49 CFR Part 23 have the maximum opportunity to participate in the performance of this contract. In this regard, the Contractor shall take all necessary and reasonable steps, in accordance with 49 CFR Part 23, to ensure that the said businesses have the maximum opportunity to compete for and perform portions of this contract. The Contractor shall not discriminate on the basis of race, color, national origin, or sex in the selection and retention of subcontractors, including procurement of materials and leases of equipment.

The Contractor shall include the above Policy and Obligation statements of this Special Provision in every subcontract, including procurement of materials and leases of equipment.

DBE/WBE CONTRACTOR FINANCE PROGRAM: On contracts where a loan has been obtained through the DBE/WBE Contractor Finance Program, the Contractor shall cooperate with the Department by making all payments due to the DBE/WBE Contractor by means of a two-payee check payable to the Lender (Bank) and the Borrower (DBE/WBE Contractor).

BREACH OF CONTRACT: Failure to carry out the requirements set forth above and in the Special Provision shall constitute a breach of contract and may result in termination of the contract or liquidated damages as provided in the special provision.

SPECIAL PROVISION FOR DISADVANTAGED BUSINESS ENTERPRISE PARTICIPATION (BDE)

Effective: September 1, 2000

Revised: March 2, 2019

FEDERAL OBLIGATION. The Department of Transportation, as a recipient of federal financial assistance, is required to take all necessary and reasonable steps to ensure nondiscrimination in the award and administration of contracts. Consequently, the federal regulatory provisions of 49 CFR Part 26 apply to this contract concerning the utilization of disadvantaged business enterprises. For the purposes of this Special Provision, a disadvantaged business enterprise (DBE) means a business certified by the Department in accordance with the requirements of 49 CFR Part 26 and listed in the Illinois Unified Certification Program (IL UCP) DBE Directory.

STATE OBLIGATION. This Special Provision will also be used by the Department to satisfy the requirements of the Business Enterprise for Minorities, Females, and Persons with Disabilities Act, 30 ILCS 575. When this Special Provision is used to satisfy state law requirements on 100 percent state-funded contracts, the federal government has no involvement in such contracts (not a federal-aid contract) and no responsibility to oversee the implementation of this Special Provision by the Department on those contracts. DBE participation on 100 percent state-funded contracts will not be credited toward fulfilling the Department's annual overall DBE goal required by the US Department of Transportation to comply with the federal DBE program requirements.

CONTRACTOR ASSURANCE. The Contractor makes the following assurance and agrees to include the assurance in each subcontract the Contractor signs with a subcontractor.

The Contractor, subrecipient, or subcontractor shall not discriminate on the basis of race, color, national origin, or sex in the performance of this contract. The Contractor shall carry out applicable requirements of 49 CFR Part 26 in the award and administration of contracts funded in whole or in part with federal or state funds. Failure by the Contractor to carry out these requirements is a material breach of this contract, which may result in the termination of this contract or such other remedy as the recipient deems appropriate, which may include, but is not limited to:

- (a) Withholding progress payments;
- (b) Assessing sanctions;
- (c) Liquidated damages; and/or
- (d) Disqualifying the Contractor from future bidding as non-responsible.

OVERALL GOAL SET FOR THE DEPARTMENT. As a requirement of compliance with 49 CFR Part 26, the Department has set an overall goal for DBE participation in its federally assisted contracts. That goal applies to all federal-aid funds the Department will expend in its federally assisted contracts for the subject reporting fiscal year. The Department is required to make a good faith effort to achieve the overall goal. The dollar amount paid to all approved DBE companies performing work called for in this contract is eligible to be credited toward fulfillment of the Department's overall goal.

CONTRACT GOAL TO BE ACHIEVED BY THE CONTRACTOR. This contract includes a specific DBE utilization goal established by the Department. The goal has been included because the Department has determined the work of this contract has subcontracting opportunities that may be suitable for performance by DBE companies. The determination is based on an assessment of the type of work, the location of the work, and the availability of DBE companies to do a part of the work. The assessment indicates, in the absence of unlawful discrimination and in an arena of fair and open competition, DBE companies can be expected to perform 8.0% of the work. This percentage is set as the DBE participation goal for this contract. Consequently, in addition to the other award criteria established for this contract, the Department will only award this contract to a bidder who makes a good faith effort to meet this goal of DBE participation in the performance of the work. A bidder makes a good faith effort for award consideration if either of the following is done in accordance with the procedures set for in this Special Provision:

- (a) The bidder documents enough DBE participation has been obtained to meet the goal or,
- (b) The bidder documents a good faith effort has been made to meet the goal, even though the effort did not succeed in obtaining enough DBE participation to meet the goal.

DBE LOCATOR REFERENCES. Bidders shall consult the IL UCP DBE Directory as a reference source for DBE-certified companies. In addition, the Department maintains a letting and item specific DBE locator information system whereby DBE companies can register their interest in providing quotes on particular bid items advertised for letting. Information concerning DBE companies willing to quote work for particular contracts may be obtained by contacting the Department's Bureau of Small Business Enterprises at telephone number (217) 785-4611, or by visiting the Department's website at:
<http://www.idot.illinois.gov/doing-business/certifications/disadvantaged-business-enterprise-certification/il-ucp-directory/index>.

BIDDING PROCEDURES. Compliance with this Special Provision is a material bidding requirement and failure of the bidder to comply will render the bid not responsive.

The bidder shall submit a DBE Utilization Plan (form SBE 2026), and a DBE Participation Statement (form SBE 2025) for each DBE company proposed for the performance of work to achieve the contract goal, with the bid. If the Utilization Plan indicates the contract goal will not be met, documentation of good faith efforts shall also be submitted. The documentation of good faith efforts must include copies of each DBE and non-DBE subcontractor quote submitted to the bidder when a non-DBE subcontractor is selected over a DBE for work on the contract. The required forms and documentation must be submitted as a single .pdf file using the "Integrated Contractor Exchange (iCX)" application within the Department's "EBids System".

The Department will not accept a Utilization Plan if it does not meet the bidding procedures set forth herein and the bid will be declared not responsive. In the event the bid is declared not responsive, the Department may elect to cause the forfeiture of the penal sum of the bidder's proposal guaranty and may deny authorization to bid the project if re-advertised for bids.

GOOD FAITH EFFORT PROCEDURES. The contract will not be awarded until the Utilization Plan is approved. All information submitted by the bidder must be complete, accurate and adequately document enough DBE participation has been obtained or document the good faith efforts of the bidder, in the event enough DBE participation has not been obtained, before the Department will commit to the performance of the contract by the bidder. The Utilization Plan will be approved by the Department if the Utilization Plan documents sufficient commercially useful DBE work to meet the contract goal or the bidder submits sufficient documentation of a good faith effort to meet the contract goal pursuant to 49 CFR Part 26, Appendix A. This means the bidder must show that all necessary and reasonable steps were taken to achieve the contract goal. Necessary and reasonable steps are those which, by their scope, intensity and appropriateness to the objective, could reasonably be expected to obtain sufficient DBE participation, even if they were not successful. The Department will consider the quality, quantity, and intensity of the kinds of efforts the bidder has made. Mere *pro forma* efforts, in other words efforts done as a matter of form, are not good faith efforts; rather, the bidder is expected to have taken genuine efforts that would be reasonably expected of a bidder actively and aggressively trying to obtain DBE participation sufficient to meet the contract goal.

- (a) The following is a list of types of action that the Department will consider as part of the evaluation of the bidder's good faith efforts to obtain participation. These listed factors are not intended to be a mandatory checklist and are not intended to be exhaustive. Other factors or efforts brought to the attention of the Department may be relevant in appropriate cases and will be considered by the Department.

- (1) Soliciting through all reasonable and available means (e.g. attendance at pre-bid meetings, advertising and/or written notices) the interest of all certified DBE companies that have the capability to perform the work of the contract. The bidder must solicit this interest within sufficient time to allow the DBE companies to respond to the solicitation. The bidder must determine with certainty if the DBE companies are interested by taking appropriate steps to follow up initial solicitations.

(2) Selecting portions of the work to be performed by DBE companies in order to increase the likelihood that the DBE goals will be achieved. This includes, where appropriate, breaking out contract work items into economically feasible units to facilitate DBE participation, even when the Contractor might otherwise prefer to perform these work items with its own forces.

(3) Providing interested DBE companies with adequate information about the plans, specifications, and requirements of the contract in a timely manner to assist them in responding to a solicitation.

(4) a. Negotiating in good faith with interested DBE companies. It is the bidder's responsibility to make a portion of the work available to DBE subcontractors and suppliers and to select those portions of the work or material needs consistent with the available DBE subcontractors and suppliers, so as to facilitate DBE participation. Evidence of such negotiation includes the names, addresses, and telephone numbers of DBE companies that were considered; a description of the information provided regarding the plans and specifications for the work selected for subcontracting; and evidence as to why additional agreements could not be reached for DBE companies to perform the work.

b. A bidder using good business judgment would consider a number of factors in negotiating with subcontractors, including DBE subcontractors, and would take a firm's price and capabilities as well as contract goals into consideration. However, the fact that there may be some additional costs involved in finding and using DBE companies is not in itself sufficient reason for a bidder's failure to meet the contract DBE goal, as long as such costs are reasonable. Also the ability or desire of a bidder to perform the work of a contract with its own organization does not relieve the bidder of the responsibility to make good faith efforts. Bidders are not, however, required to accept higher quotes from DBE companies if the price difference is excessive or unreasonable. In accordance with the above Bidding Procedures, the documentation of good faith efforts must include copies of each DBE and non-DBE subcontractor quote submitted to the bidder when a non-DBE subcontractor was selected over a DBE for work on the contract.

(5) Not rejecting DBE companies as being unqualified without sound reasons based on a thorough investigation of their capabilities. The bidder's standing within its industry, membership in specific groups, organizations, or associations and political or social affiliations (for example union vs. non-union employee status) are not legitimate causes for the rejection or non-solicitation of bids in the bidder's efforts to meet the project goal.

(6) Making efforts to assist interested DBE companies in obtaining bonding, lines of credit, or insurance as required by the recipient or Contractor.

(7) Making efforts to assist interested DBE companies in obtaining necessary equipment, supplies, materials, or related assistance or services.

(8) Effectively using the services of available minority/women community organizations; minority/women contractors' groups; local, state, and federal minority/women business assistance offices; and other organizations as allowed on a case-by-case basis to provide assistance in the recruitment and placement of DBE companies.

(b) If the Department determines the bidder has made a good faith effort to secure the work commitment of DBE companies to meet the contract goal, the Department will award the contract provided it is otherwise eligible for award. If the Department determines the bidder has failed to meet the requirements of this Special Provision or that a good faith effort has not been made, the Department will notify the responsible company official designated in the Utilization Plan that the bid is not responsive. The notification will also include a statement of reasons for the adverse determination. If the Utilization Plan is not approved because it is deficient as a technical matter, unless waived by the Department, the bidder will be notified and will be allowed no more than a five calendar day period to cure the deficiency.

(c) The bidder may request administrative reconsideration of an adverse determination by emailing the Department at "DOT.DBE.UP@illinois.gov" within the five calendar days after the receipt of the notification of the determination. The determination shall become final if a request is not made on or before the fifth calendar day. A request may provide additional written documentation or argument concerning the issues raised in the determination statement of reasons, provided the documentation and arguments address efforts made prior to submitting the bid. The request will be reviewed by the Department's Reconsideration Officer. The Reconsideration Officer will extend an opportunity to the bidder to meet in person to consider all issues of documentation and whether the bidder made a good faith effort to meet the goal. After the review by the Reconsideration Officer, the bidder will be sent a written decision within ten working days after receipt of the request for reconsideration, explaining the basis for finding that the bidder did or did not meet the goal or make adequate good faith efforts to do so. A final decision by the Reconsideration Officer that a good faith effort was made shall approve the Utilization Plan submitted by the bidder and shall clear the contract for award. A final decision that a good faith effort was not made shall render the bid not responsive.

CALCULATING DBE PARTICIPATION. The Utilization Plan values represent work anticipated to be performed and paid for upon satisfactory completion. The Department is only able to count toward the achievement of the overall goal and the contract goal the value of payments made for the work actually performed by DBE companies. In addition, a DBE must perform a commercially useful function on the contract to be counted. A commercially useful function is generally performed when the DBE is responsible for the work and is carrying out its responsibilities by actually performing, managing, and supervising the work involved. The Department and Contractor are governed by the provisions of 49 CFR Part 26.55(c) on questions of commercially useful functions as it affects the work. Specific counting guidelines are provided in 49 CFR Part 26.55, the provisions of which govern over the summary contained herein.

(a) DBE as the Contractor: 100 percent goal credit for that portion of the work performed by the DBE's own forces, including the cost of materials and supplies. Work that a DBE subcontracts to a non-DBE does not count toward the DBE goals.

(b) DBE as a joint venture Contractor: 100 percent goal credit for that portion of the total dollar value of the contract equal to the distinct, clearly defined portion of the work performed by the DBE's own forces.

(c) DBE as a subcontractor: 100 percent goal credit for the work of the subcontract performed by the DBE's own forces, including the cost of materials and supplies, excluding the purchase of materials and supplies or the lease of equipment by the DBE subcontractor from the Contractor or its affiliates. Work that a DBE subcontractor in turn subcontracts to a non-DBE does not count toward the DBE goal.

(d) DBE as a trucker: 100 percent goal credit for trucking participation provided the DBE is responsible for the management and supervision of the entire trucking operation for which it is responsible. At least one truck owned, operated, licensed, and insured by the DBE must be used on the contract. Credit will be given for the following:

(1) The DBE may lease trucks from another DBE firm, including an owner-operator who is certified as a DBE. The DBE who leases trucks from another DBE receives credit for the total value of the transportation services the lessee DBE provides on the contract.

(2) The DBE may also lease trucks from a non-DBE firm, including from an owner-operator. The DBE who leases trucks from a non-DBE is entitled to credit only for the fee or commission it receives as a result of the lease arrangement.

(e) DBE as a material supplier:

(1) 60 percent goal credit for the cost of the materials or supplies purchased from a DBE regular dealer.

(2) 100 percent goal credit for the cost of materials or supplies obtained from a DBE manufacturer.

(3) 100 percent credit for the value of reasonable fees and commissions for the procurement of materials and supplies if not a DBE regular dealer or DBE manufacturer.

CONTRACT COMPLIANCE. Compliance with this Special Provision is an essential part of the contract. The Department is prohibited by federal regulations from crediting the participation of a DBE included in the Utilization Plan toward either the contract goal or the Department's overall goal until the amount to be applied toward the goals has been paid to the DBE. The following administrative procedures and remedies govern the compliance by the Contractor with the contractual obligations established by the Utilization Plan. After approval of the Utilization Plan and award of the contract, the Utilization Plan and individual DBE Participation Statements become part of the contract. If the Contractor did not succeed in obtaining enough DBE participation to achieve the advertised contract goal, and the Utilization Plan was approved and contract awarded based upon a determination of good faith, the total dollar value of DBE work calculated in the approved Utilization Plan as a percentage of the awarded contract value shall become the amended contract goal. All work indicated for performance by an approved DBE shall be performed, managed, and supervised by the DBE executing the DBE Participation Commitment Statement.

(a) NO AMENDMENT. No amendment to the Utilization Plan may be made without prior written approval from the Department's Bureau of Small Business Enterprises. All requests for amendment to the Utilization Plan shall be emailed to the Department at DOT.DB.E.UP@illinois.gov.

(b) CHANGES TO WORK. Any deviation from the DBE condition-of-award or contract plans, specifications, or special provisions must be approved, in writing, by the Department as provided elsewhere in the Contract. The Contractor shall notify affected DBEs in writing of any changes in the scope of work which result in a reduction in the dollar amount condition-of-award to the contract. Where the revision includes work committed to a new DBE subcontractor, not previously involved in the project, then a Request for Approval of Subcontractor, Department form BC 260A or AER 260A, must be signed and submitted. If the commitment of work is in the form of additional tasks assigned to an existing subcontract, a new Request for Approval of Subcontractor will not be required. However, the Contractor must document efforts to assure the existing DBE subcontractor is capable of performing the additional work and has agreed in writing to the change.

(c) SUBCONTRACT. The Contractor must provide copies of DBE subcontracts to the Department upon request. Subcontractors shall ensure that all lower tier subcontracts or agreements with DBEs to supply labor or materials be performed in accordance with this Special Provision.

(d) ALTERNATIVE WORK METHODS. In addition to the above requirements for reductions in the condition of award, additional requirements apply to the two cases of Contractor-initiated work substitution proposals. Where the contract allows alternate work methods which serve to delete or create underruns in condition of award DBE work, and the Contractor selects that alternate method or, where the Contractor proposes a substitute work method or material that serves to diminish or delete work committed to a DBE and replace it with other work, then the Contractor must demonstrate one of the following:

(1) The replacement work will be performed by the same DBE (as long as the DBE is certified in the respective item of work) in a modification of the condition of award; or

(2) The DBE is aware its work will be deleted or will experience underruns and has agreed in writing to the change. If this occurs, the Contractor shall substitute other work of equivalent value to a certified DBE or provide documentation of good faith efforts to do so; or

(3) The DBE is not capable of performing the replacement work or has declined to perform the work at a reasonable competitive price. If this occurs, the Contractor shall substitute other work of equivalent value to a certified DBE or provide documentation of good faith efforts to do so.

(e) TERMINATION AND REPLACEMENT PROCEDURES. The Contractor shall not terminate or replace a DBE listed on the approved Utilization Plan, or perform with other forces work designated for a listed DBE except as provided in this Special Provision. The Contractor shall utilize the specific DBEs listed to perform the work and supply the materials for which each is listed unless the Contractor obtains the Department's written consent as provided in subsection (a) of this part. Unless Department consent is provided for termination of a DBE subcontractor, the Contractor shall not be entitled to any payment for work or material unless it is performed or supplied by the DBE in the Utilization Plan.

As stated above, the Contractor shall not terminate or replace a DBE subcontractor listed in the approved Utilization Plan without prior written consent. This includes, but is not limited to, instances in which the Contractor seeks to perform work originally designated for a DBE subcontractor with its own forces or those of an affiliate, a non-DBE firm, or with another DBE firm. Written consent will be granted only if the Bureau of Small Business Enterprises agrees, for reasons stated in its concurrence document, that the Contractor has good cause to terminate or replace the DBE firm. Before transmitting to the Bureau of Small Business Enterprises any request to terminate and/or substitute a DBE subcontractor, the Contractor shall give notice in writing to the DBE subcontractor, with a copy to the Bureau, of its intent to request to terminate and/or substitute, and the reason for the request. The Contractor shall give the DBE five days to respond to the Contractor's notice. The DBE so notified shall advise the Bureau and the Contractor of the reasons, if any, why it objects to the proposed termination of its subcontract and why the Bureau should not approve the Contractor's action. If required in a particular case as a matter of public necessity, the Bureau may provide a response period shorter than five days.

For purposes of this paragraph, good cause includes the following circumstances:

- (1) The listed DBE subcontractor fails or refuses to execute a written contract;
- (2) The listed DBE subcontractor fails or refuses to perform the work of its subcontract in a way consistent with normal industry standards. Provided, however, that good cause does not exist if the failure or refusal of the DBE subcontractor to perform its work on the subcontract results from the bad faith or discriminatory action of the Contractor;
- (3) The listed DBE subcontractor fails or refuses to meet the Contractor's reasonable, nondiscriminatory bond requirements;
- (4) The listed DBE subcontractor becomes bankrupt, insolvent, or exhibits credit unworthiness;
- (5) The listed DBE subcontractor is ineligible to work on public works projects because of suspension and debarment proceedings pursuant 2 CFR Parts 180, 215 and 1200 or applicable state law.
- (6) The Contractor has determined the listed DBE subcontractor is not a responsible contractor;
- (7) The listed DBE subcontractor voluntarily withdraws from the projects and provides written notice to the Contractor of its withdrawal;
- (8) The listed DBE is ineligible to receive DBE credit for the type of work required;
- (9) A DBE owner dies or becomes disabled with the result that the listed DBE subcontractor is unable to complete its work on the contract;
- (10) Other documented good cause that compels the termination of the DBE subcontractor. Provided, that good cause does not exist if the Contractor seeks to terminate a DBE it relied upon to obtain the contract so that the Contractor can self-perform the work for which the DBE contractor was engaged or so that the Contractor can substitute another DBE or non-DBE contractor after contract award.

When a DBE is terminated or fails to complete its work on the Contract for any reason, the Contractor shall make a good faith effort to find another DBE to substitute for the original DBE to perform at least the same amount of work under the contract as the terminated DBE to the extent needed to meet the established Contract goal. The good faith efforts shall be documented by the Contractor. If the Department requests documentation under this provision, the Contractor shall submit the documentation within seven days, which may be extended for an additional seven days if necessary at the request of the Contractor. The Department will provide a written determination to the Contractor stating whether or not good faith efforts have been demonstrated.

(f) FINAL PAYMENT. After the performance of the final item of work or delivery of material by a DBE and final payment therefore to the DBE by the Contractor, but not later than 30 calendar days after payment has been made by the Department to the Contractor for such work or material, the Contractor shall submit a DBE Payment Agreement on Department form SBE 2115 to the Resident Engineer. If full and final payment has not been made to the DBE, the DBE Payment Agreement shall indicate whether a disagreement as to the payment required exists between the Contractor and the DBE or if the Contractor believes the work has not been satisfactorily

completed. If the Contractor does not have the full amount of work indicated in the Utilization Plan performed by the DBE companies indicated in the Utilization Plan and after good faith efforts are reviewed, the Department may deduct from contract payments to the Contractor the amount of the goal not achieved as liquidated and ascertained damages. The Contractor may request an administrative reconsideration of any amount deducted as damages pursuant to subsection (h) of this part.

(g) **ENFORCEMENT.** The Department reserves the right to withhold payment to the Contractor to enforce the provisions of this Special Provision. Final payment shall not be made on the contract until such time as the Contractor submits sufficient documentation demonstrating achievement of the goal in accordance with this Special Provision or after liquidated damages have been determined and collected.

(h) **RECONSIDERATION.** Notwithstanding any other provision of the contract, including but not limited to Article 109.09 of the Standard Specifications, the Contractor may request administrative reconsideration of a decision to deduct the amount of the goal not achieved as liquidated damages. A request to reconsider shall be delivered to the Contract Compliance Section and shall be handled and considered in the same manner as set forth in paragraph (c) of "Good Faith Effort Procedures" of this Special Provision, except a final decision that a good faith effort was not made during contract performance to achieve the goal agreed to in the Utilization Plan shall be the final administrative decision of the Department. The result of the reconsideration process is not administratively appealable to the U.S. Department of Transportation.

SPECIAL PROVISION FOR WEEKLY DBE TRUCKING REPORTS (BDE)

Effective: June 2, 2012

Revised: April 2, 2015

The Contractor shall submit a weekly report of Disadvantaged Business Enterprise (DBE) trucks hired by the Contractor or subcontractors (i.e. not owned by the Contractor or subcontractors) that are used for DBE goal credit.

The report shall be submitted to the Resident Engineer on Division of Aeronautics Form "AER 723" within ten business days following the reporting period. The reporting period shall be Monday through Sunday for each week reportable trucking activities occur.

Any costs associated with providing weekly DBE trucking reports shall be considered as included in the contract unit prices bid for the various items of work involved and no additional compensation will be allowed.

SPECIAL PROVISION FOR SUBCONTRACTOR MOBILIZATION PAYMENTS

Effective: November 2, 2017

Revised: April 1, 2019

To account for the preparatory work and the operations necessary for the movement of subcontractor personnel, equipment, supplies, and incidentals to the project site and for all other work or operations that must be performed or costs incurred when beginning work approved for subcontracting according to Section 80-01 of the Standard Specifications, the Contractor shall make a mobilization payment to each subcontractor.

This mobilization payment shall be made at least seven days prior to the subcontractor starting work. The amount paid shall be at the following percentage of the amount of the subcontract reported on form AER 260A submitted for the approval of the subcontractor's work.

Value of Subcontract Reported on Form AER 260A	Mobilization Percentage
Less than \$10,000	25%
\$10,000 to less than \$20,000	20%
\$20,000 to less than \$40,000	18%
\$40,000 to less than \$60,000	16%
\$60,000 to less than \$80,000	14%
\$80,000 to less than \$100,000	12%
\$100,000 to less than \$250,000	10%
\$250,000 to less than \$500,000	9%
\$500,000 to \$750,000	8%
Over \$750,000	7%

The mobilization payment to the subcontractor is an advance payment of the reported amount of the subcontract and is not a payment in addition to the amount of the subcontract; therefore, the amount of the advance payment will be deducted from future progress payments.

This provision shall be incorporated directly or by reference into each subcontract approved by the Department.

SPECIAL PROVISION FOR PAYMENTS TO SUBCONTRACTORS

Effective: November 2, 2017

Federal regulations found at 49 CFR §26.29 mandate the Department to establish a contract clause to require Contractors to pay subcontractors for satisfactory performance of their subcontracts and to set the time for such payments.

State law also addresses the timing of payments to be made to subcontractors and material suppliers. Section 7 of the Prompt Payment Act, 30 ILCS 540/7, requires that when a Contractor receives any payment from the Department, the Contractor shall make corresponding, proportional payments to each subcontractor and material supplier performing work or supplying material within 15 calendar days after receipt of the Department payment. Section 7 of the Act further provides that interest in the amount of two percent per month, in addition to the payment due, shall be paid to any subcontractor or material supplier by the Contractor if the payment required by the Act is withheld or delayed without reasonable cause. The Act also provides that the time for payment required and the calculation of any interest due applies to transactions between subcontractors and lower-tier subcontractors and material suppliers throughout the contracting chain.

This Special Provision establishes the required federal contract clause, and adopts the 15 calendar day requirement of the State Prompt Payment Act for purposes of compliance with the federal regulation regarding payments to subcontractors. This contract is subject to the following payment obligations.

When progress payments are made to the Contractor according to Article 90-07 of the Standard Specifications, the Contractor shall make a corresponding payment to each subcontractor and material supplier in proportion to the work satisfactorily completed by each subcontractor and for the material supplied to perform any work of the contract. The proportionate amount of partial payment due to each subcontractor and material supplier throughout the contracting chain shall be determined by the quantities measured or otherwise determined as eligible for payment by the Department and included in the progress payment to the Contractor. Subcontractors and material suppliers shall be paid by the Contractor within 15 calendar days after the receipt of payment from the Department. The Contractor shall not hold retainage from the subcontractors. These obligations shall also apply to any payments made by subcontractors and material suppliers to their subcontractors and material suppliers; and to all payments made to lower tier subcontractors and material suppliers throughout the contracting chain. Any payment or portion of a payment subject to this provision may only be withheld from the subcontractor or material supplier to whom it is due for reasonable cause. If reasonable cause is asserted, written notice shall be provided to the applicable subcontractor and/or material supplier and the Engineer within five days of the Contractor receiving payment. The written notice shall identify the contract number, the subcontract or material purchase agreement, a detailed reason for refusal, the value of payment being withheld, and the specific remedial actions required of the subcontractor and/or material supplier so that payment can be made.

This Special Provision does not create any rights in favor of any subcontractor or material supplier against the State or authorize any cause of action against the State on account of any payment, nonpayment, delayed payment, or interest claimed by application of the State Prompt Payment Act. The Department will not approve any delay or postponement of the 15 day requirement except for reasonable cause shown after notice and hearing pursuant to Section 7(b) of the State Prompt Payment Act. State law creates other and additional remedies available to any subcontractor or material supplier, regardless of tier, who has not been paid for work properly performed or material furnished. These remedies are a lien against public funds set forth in Section 23(c) of the Mechanics Lien Act, 770 ILCS 60/23(c), and a recovery on the Contractor's payment bond according to the Public Construction Bond Act, 30 ILCS 550.

SPECIAL PROVISION FOR SUBCONTRACTOR AND DBE PAYMENT REPORTING (BDE)

Effective: April 2, 2018

Subcontractor and Disadvantaged Business Enterprise Payment Reporting

The Contractor shall report all payments made to the following parties:

- (a) first tier subcontractors;
- (b) lower tier subcontractors affecting disadvantaged business enterprise (DBE) goal credit;
- (c) material suppliers or trucking firms that are part of the Contractor's submitted DBE utilization plan.

The report shall be made through the Department's on-line subcontractor payment reporting system within 21 days of making the payment.

SPECIAL PROVISION FOR ADDITIONAL STATE REQUIREMENTS FOR FEDERAL-AID CONSTRUCTION CONTRACTS

Effective: February 1, 1969

Revised: January 1, 2017

EQUAL EMPLOYMENT OPPORTUNITY

In the event of the Contractor's noncompliance with the provisions of this Equal Employment Opportunity Clause, the Illinois Human Rights Act, or the Illinois Department of Human Rights Rules and Regulations, the Contractor may be declared ineligible for future contracts or subcontracts with the State of Illinois or any of its political sub-divisions or municipal corporations, and the contract may be cancelled or voided in whole or in part, and such other sanctions or penalties may be imposed or remedies invoked as provided by statute or regulation.

During the performance of this Contract, the Contractor agrees as follows:

- (1) That it will not discriminate against any employee or applicant for employment because of race, color, religion, sex, sexual orientation, marital status, order of protection status, national origin or ancestry, citizenship status, age, physical or mental disability

unrelated to ability, military status, or an unfavorable discharge from military service; and further that it will examine all job classifications to determine if minority persons or women are underutilized and will take appropriate affirmative action to rectify any such underutilization.

(2) That, if it hires additional employees in order to perform this contract or any portion hereof, it will determine the availability (in accordance with the Illinois Department of Human Rights Rules and Regulations) of minorities and women in the area(s) from which it may reasonably recruit and it will hire for each job classification for which employees are hired in such a way that minorities and women are not underutilized.

(3) That, in all solicitations or advertisements for employees placed by it or on its behalf, it will state that all applicants will be afforded equal opportunity without discrimination because of race, color, religion, sex, sexual orientation, marital status, order of protection status, national origin or ancestry, citizenship status, age, physical or mental disability unrelated to ability, military status, or an unfavorable discharge from military service.

(4) That it will send to each labor organization or representative of workers with which it has or is bound by a collective bargaining or other agreement or understanding, a notice advising such labor organization or representative of the Contractor's obligations under the Illinois Human Rights Act and the Illinois Department of Human Rights Rules and Regulations. If any labor organization or representative fails or refuses to cooperate with the Contractor in its efforts to comply with such Act and Rules and Regulations, the Contractor will promptly so notify the Illinois Department of Human Rights and IDOT and will recruit employees from other sources when necessary to fulfill its obligations thereunder.

(5) That it will submit reports as required by the Illinois Department of Human Rights Rules and Regulations, furnish all relevant information as may from time to time be requested by the Illinois Department of Human Rights or IDOT, and in all respects comply with the Illinois Human Rights Act and the Illinois Department of Human Rights Rules and Regulations.

(6) That it will permit access to all relevant books, records, accounts, and work sites by personnel of IDOT and the Illinois Department of Human Rights for purposes of investigation to ascertain compliance with the Illinois Human Rights Act and the Illinois Department of Human Rights Rules and Regulations.

(7) That it will include verbatim or by reference the provisions of this clause in every subcontract it awards under which any portion of the contract obligations are undertaken or assumed, so that the provisions will be binding upon the subcontractor. In the same manner as with other provisions of this contract, the Contractor will be liable for compliance with applicable provisions of this clause by subcontractors; and further it will promptly notify IDOT and the Illinois Department of Human Rights in the event any subcontractor fails or refuses to comply with these provisions. In addition, the Contractor will not utilize any subcontractor declared by the Illinois Human Rights Commission to be ineligible for contracts or subcontracts with the State of Illinois or any of its political subdivisions or municipal corporations.

SPECIAL PROVISION FOR NPDES CERTIFICATION

In accordance with the provisions of the Illinois Environmental Protection Act, the Illinois Pollution Control Board Rules and Regulations (35 Ill. Adm. Code, Subtitle C, Chapter I), and the Clean Water Act, and the regulations thereunder, this certification is required for all construction contracts that will result in the disturbance of one or more acres total land area.

The bidder certifies under penalty of law that he/she understands the terms and conditions of the general National Pollutant Discharge Elimination System (NPDES) permit (ILR100000) that authorizes the storm water discharges associated with industrial activity from the construction site identified as part of this certification.

The Airport Owner or its Agent will:

- 1) prepare, sign and submit the Notice of Intent (NOI)
- 2) conduct site inspections and complete and file the inspection reports
- 3) submit Incidence of Non-Compliance (ION) forms
- 4) submit Notice of Termination (NOT) form

Prior to the issuance of the Notice-to-Proceed, for each erosion control measure identified in the Storm Water Pollution Prevention Plan, the contractor or subcontractor responsible for the control measure(s) must sign the above certification (forms to be provided by the Department).

SPECIAL PROVISION FOR COMPLETION TIME VIA CALENDAR DAYS

It being understood and agreed that the completion within the time limit is an essential part of the contract, the bidder agrees to complete the work within 40 calendar days, unless additional time is granted by the Engineer in accordance with the provisions of the specifications. In case of failure to complete the work on or before the time named herein, or within such extra time as may have been

allowed by extensions, the bidder agrees that the Department of Transportation shall withhold from such sum as may be due him/her under the terms of this contract, the costs, as set forth in Section 80-09 Failure to Complete on Time of the Standard Specifications, which costs shall be considered and treated not as a penalty but as damages due to the State from the bidder by reason of the failure of the bidder to complete the work within the time specified in the contract.

State of Illinois
Department of Transportation

SPECIAL PROVISION
FOR
SECTION 80 PROSECUTION AND PROGRESS

This Special Provision amends the provisions of the Standard Specifications for Construction of Airports, adopted April 1, 2012 and shall be construed to be a part thereof, superseding any conflicting provisions thereof applicable to the work under the contract.

80-09 FAILURE TO COMPLETE ON TIME.

DELETE: "See contract documents for current schedule of deductions."

ADD:

Schedule of Deductions for Each Day of Overrun in Contract Time			
Original Contract Amount		Daily Charges	
From More Than	To and Including	Calendar Day	Work Day
\$ 0	\$ 100,000	\$ 475	\$ 675
100,000	500,000	750	1,050
500,000	1,000,000	1,025	1,425
1,000,000	3,000,000	1,275	1,725
3,000,000	6,000,000	1,425	2,000
6,000,000	12,000,000	2,300	3,450
12,000,000	And over	6,775	9,525

State of Illinois
Department of Transportation

SPECIAL PROVISION
FOR
SECTION 90 MEASUREMENT AND PAYMENT

This Special Provision amends the provisions of the Standard Specifications for Construction of Airports, adopted April 1, 2012 and shall be construed to be a part thereof, superseding any conflicting provisions thereof applicable to the work under the contract.

90-07 PARTIAL PAYMENTS.

DELETE: The entire section.

ADD: Partial payments will be made to the Contractor at least once each month as the work progresses. The payments will be based upon estimates, prepared by the Resident Engineer, of the value of the work performed and materials complete and in place in accordance with the contract, plans, and specifications. Such partial payments may also include the delivered actual cost of those materials stockpiled and stored in accordance with the Section 90-08 PAYMENT FOR MATERIALS ON HAND. From the amount of partial payment so determined on Federal-Aid projects, there shall be deducted an amount up to ten percent of the cost of the completed work which shall be retained until all conditions necessary for financial closeout of the project are satisfied. The amount of the estimate approved as due for payment will be vouchered by the Department and presented to the State Comptroller for payment. No amount less than \$1,000.00 will be approved for payment other than the final payment. A final voucher for under \$5.00 shall not be paid except through electronic funds transfer. (15 ILCS 405/9(b-1))

It is understood and agreed that the Contractor shall not be entitled to demand or receive partial payment based on quantities of work in excess of those provided in the proposal or covered by approved change orders, except when such excess quantities have been determined by the Engineer to be a part of the final quantity for the item of work in question.

No partial payment shall bind the Department to the acceptance of any materials or work in place as to quality or quantity. All partial payments are subject to correction at the time of final payment as provided in Section 90-09 ACCEPTANCE AND FINAL PAYMENT.

Progress payments may be reduced by liens filed pursuant to Section 23(c) of the Mechanics Lien Act, 770 ILCS 60/23(c).

If a Contractor or subcontractor has defaulted on a loan issued under the Department's Disadvantaged Business Revolving Loan Program (20 ILCS 2705/2705-610) progress payments may be reduced pursuant to the terms of that loan agreement. In such cases, the amount of the estimate related to the work performed by the Contractor or subcontractor, in default of the loan agreement, will be offset, in whole or in part, and vouchered by the Department to the Working Capital Revolving Fund or designated escrow account. Payment for the work shall be considered as issued and received by the Contractor or subcontractor on the date of the offset voucher. Further, the amount of the offset voucher shall be a credit against the Department's obligation to pay the Contractor, the Contractor's obligation to pay the subcontractor, and the Contractor's or subcontractor's total loan indebtedness to the Department. The offset shall continue until such time as the entire loan indebtedness is satisfied. The Department will notify the Contractor and Fund Control Agent in a timely manner of such offset. The Contractor or subcontractor shall not be entitled to additional payment in consideration of the offset.

In accordance with 49 USC § 47111, the Department will not make payments totaling more than 90 percent of the contract until all conditions necessary for financial closeout of the project are satisfied.

The failure to perform any requirement, obligation, or term of the contract by the Contractor shall be reason for withholding any progress payments until the Department determines that compliance has been achieved.

90-10 TRUST AGREEMENT OPTION.

DELETE: The entire section.

APPENDIX A – FEDERAL AVIATION ADMINISTRATION (FAA) REQUIRED CONTRACT PROVISIONS

A1 ACCESS TO RECORDS AND REPORTS

A1.1 CONTRACT CLAUSE

ACCESS TO RECORDS AND REPORTS

The Contractor must maintain an acceptable cost accounting system. The Contractor agrees to provide the sponsor, the Federal Aviation Administration, and the Comptroller General of the United States or any of their duly authorized representatives, access to any books, documents, papers, and records of the contractor which are directly pertinent to the specific contract for the purpose of making audit, examination, excerpts and transcriptions. The Contractor agrees to maintain all books, records and reports required under this contract for a period of not less than three years after final payment is made and all pending matters are closed.

A2 AFFIRMATIVE ACTION REQUIREMENTS

A2.1 SOLICITATION CLAUSE

NOTICE OF REQUIREMENT FOR AFFIRMATIVE ACTION TO ENSURE EQUAL EMPLOYMENT OPPORTUNITY

1. The Offeror's or Bidder's attention is called to the "Equal Opportunity Clause" and the "Standard Federal Equal Employment Opportunity Construction Contract Specifications" set forth herein.
2. The goals and timetables for minority and female participation, expressed in percentage terms for the contractor's aggregate workforce in each trade on all construction work in the covered area, are as follows:

The following goal for female utilization in each construction craft and trade shall apply to all Contractors holding Federal and federally-assisted construction contracts and subcontracts in excess of \$10,000. The goal is applicable to the Contractor's total on-site construction workforce, regardless of whether or not part of that workforce is performing work on a Federal, federally assisted or nonfederally related construction contract or subcontract.

AREA COVERED (STATEWIDE)

Goals for Women apply nationwide.

GOAL

Goal (percent)

Female Utilization..... 6.9

Until further notice, the following goals for minority utilization in each construction craft and trade shall apply to all Contractors holding Federal and federally-assisted construction contracts and subcontracts in excess of \$10,000 to be performed in the respective geographical areas. The goals are applicable to the Contractor's total on-site construction workforce, regardless of whether or not part of that workforce is performing work on a Federal, federally-assisted or nonfederally related construction contract or subcontract.

<u>Economic Area (percent)</u>	Goal
056 Paducah, KY: Non-SMSA Counties - IL - Hardin, Massac, Pope KY - Ballard, Caldwell, Calloway, Carlisle, Crittenden, Fulton, Graves, Hickman, Livingston, Lyon, McCracken, Marshall	5.2
080 Evansville, IN: Non-SMSA Counties - IL - Edwards, Gallatin, Hamilton, Lawrence, Saline, Wabash, White IN - Dubois, Knox, Perry, Pike, Spencer KY - Hancock, Hopkins, McLean, Mublenberg, Ohio, Union, Webster	3.5
081 Terre Haute, IN: Non-SMSA Counties - IL - Clark, Crawford IN - Parke	2.5
083 Chicago, IL: SMSA Counties: 1600 Chicago, IL - IL - Cook, DuPage, Kane, Lake, McHenry, Will	19.6

3740 Kankakee, IL - IL - Kankakee	9.1
Non-SMSA Counties IL - Bureau, DeKalb, Grundy, Iroquois, Kendall, LaSalle, Livingston, Putnam IN - Jasper, Laporte, Newton, Pulaski, Starke	18.4
084 Champaign - Urbana, IL: SMSA Counties: 1400 Champaign - Urbana - Rantoul, IL - IL - Champaign	7.8
Non-SMSA Counties - IL - Coles, Cumberland, Douglas, Edgar, Ford, Piatt, Vermilion	4.8
085 Springfield - Decatur, IL: SMSA Counties: 2040 Decatur, IL - IL - Macon	7.6
7880 Springfield, IL - IL - Menard, Sangamon	4.5
Non-SMSA Counties IL - Cass, Christian, Dewitt, Logan, Morgan, Moultrie, Scott, Shelby	4.0
086 Quincy, IL: Non-SMSA Counties	3.1
IL - Adams, Brown, Pike MO - Lewis, Marion, Pike, Ralls	
087 Peoria, IL: SMSA Counties: 1040 Bloomington - Normal, IL - IL - McLean	2.5
6120 Peoria, IL - IL - Peoria, Tazewell, Woodford	4.4
Non-SMSA Counties - IL - Fulton, Knox, McDonough, Marshall, Mason, Schuyler, Stark, Warren	3.3
088 Rockford, IL: SMSA Counties: 6880 Rockford, IL - IL - Boone, Winnebago	6.3
Non-SMSA Counties - IL - Lee, Ogle, Stephenson	4.6
098 Dubuque, IA: Non-SMSA Counties - IL - JoDaviess IA - Atlamakee, Clayton, Delaware, Jackson, Winnesheik WI - Crawford, Grant, Lafayette	0.5
099 Davenport, Rock Island, Moline, IA - IL: SMSA Counties: 1960 Davenport, Rock Island, Moline, IA - IL - IL - Henry, Rock Island IA - Scott	4.6
Non-SMSA Counties - IL - Carroll, Hancock, Henderson, Mercer, Whiteside IA - Clinton, DesMoines, Henry, Lee, Louisa, Muscatine MO - Clark	3.4
107 St. Louis, MO: SMSA Counties: 7040 St. Louis, MO - IL - IL - Clinton, Madison, Monroe, St. Clair MO - Franklin, Jefferson, St. Charles, St. Louis, St. Louis City	14.7
Non-SMSA Counties - IL - Alexander, Bond, Calhoun, Clay, Effingham, Fayette, Franklin, Greene,	11.4

Jackson, Jasper, Jefferson, Jersey, Johnson, Macoupin, Marion,
Montgomery, Perry, Pulaski, Randolph, Richland, Union, Washington,
Wayne, Williamson
MO - Bollinger, Butler, Cape Girardeau, Carter, Crawford, Dent, Gasconade,
Iron, Lincoln, Madison, Maries, Mississippi, Montgomery, Perry, Phelps,
Reynolds, Ripley, St. Francois, St. Genevieve, Scott, Stoddard, Warren,
Washington, Wayne

These goals are applicable to all of the contractor's construction work (whether or not it is Federal or federally-assisted) performed in the covered area. If the contractor performs construction work in a geographical area located outside of the covered area, it shall apply the goals established for such geographical area where the work is actually performed. With regard to this second area, the contractor also is subject to the goals for both its federally involved and non-federally involved construction.

The Contractor's compliance with the Executive Order and the regulations in 41 CFR Part 60-4 shall be based on its implementation of the Equal Opportunity Clause, specific affirmative action obligations required by the specifications set forth in 41 CFR 60-4.3(a), and its efforts to meet the goals. The hours of minority and female employment and training must be substantially uniform throughout the length of the contract, and in each trade, and the contractor shall make a good faith effort to employ minorities and women evenly on each of its projects. The transfer of minority or female employees or trainees from Contractor to Contractor or from project to project for the sole purpose of meeting the Contractor's goals shall be a violation of the contract, the Executive Order and the regulations in 41 CFR Part 60-4. Compliance with the goals will be measured against the total work hours performed.

3. The Contractor shall provide written notification to the Director of the Office of Federal Contract Compliance Programs (OFCCP) within 10 working days of award of any construction subcontract in excess of \$10,000 at any tier for construction work under the contract resulting from this solicitation. The notification shall list the name, address, and telephone number of the subcontractor; employer identification number of the subcontractor; estimated dollar amount of the subcontract; estimated starting and completion dates of the subcontract; and the geographical area in which the subcontract is to be performed.

4. As used in this notice and in the contract resulting from this solicitation, the "covered area" is Rantoul, Illinois; Champaign County.

A3 BREACH OF CONTRACT TERMS

A3.1 CONTRACT CLAUSE

This provision is required for all contracts that exceed the simplified acquisition threshold as stated in 2 CFR Part 200, Appendix II (A). This threshold is occasionally adjusted for inflation and is now equal to \$150,000.

BREACH OF CONTRACT TERMS

Any violation or breach of terms of this contract on the part of the contractor or its subcontractors may result in the suspension or termination of this contract or such other action that may be necessary to enforce the rights of the parties of this agreement.

Owner will provide the Contractor written notice that describes the nature of the breach and corrective actions the Contractor must undertake in order to avoid termination of the contract. Owner reserves the right to withhold payments to Contractor until such time the Contractor corrects the breach or the Owner elects to terminate the contract. The Owner's notice will identify a specific date by which the Contractor must correct the breach. Owner may proceed with termination of the contract if the Contractor fails to correct the breach by deadline indicated in the Owner's notice.

The duties and obligations imposed by the Contract Documents and the rights and remedies available thereunder are in addition to, and not a limitation of, any duties, obligations, rights and remedies otherwise imposed or available by law.

A4 BUY AMERICAN PREFERENCE

A4.1 CONTRACT CLAUSE

- (a) The Aviation Safety and Capacity Expansion Act of 1990 provides that preference be given to steel and manufactured products produced in the United States when funds are expended pursuant to a grant issued under the Airport Improvement Program (AIP).
- (b) Any and all steel products used in the performance of this contract by the Contractor, subcontractors, producers, and suppliers are required to adhere to the Illinois Steel Products Procurement Act, which requires that all steel items be of 100 percent domestic origin and manufacture. Any products listed under the Federal Aviation Administration's (FAA) nationwide approved list of "Equipment Meeting Buy American Requirements" shall be deemed as meeting the requirements of the Illinois Steel Products Procurement Act.
- (c) The successful bidder will be required to assure that only domestic steel and domestically manufactured products will be used by the Contractor, subcontractors, producers, and suppliers in the performance of this contract. The North American Free Trade Agreement (NAFTA) specifically excluded federal grant programs such as the AIP. Therefore, NAFTA does not change the requirement to comply with the Buy American requirement in the Act. Exceptions to this are for products, other than steel, that:
 - (1) the FAA has determined, under the Aviation Safety and Capacity Expansion Act of 1990, are not produced in the United States in sufficient and reasonably available quantities or of a satisfactory quality;
 - (2) the FAA has determined, under the Aviation Safety and Capacity Expansion Act of 1990, that domestic preference would be inconsistent with the public interest;

- (3) the FAA has determined that inclusion of domestic material will increase the cost of the overall project contract by more than 25 percent; or
- (4) the FAA has determined, under the Aviation Safety and Capacity Expansion Act of 1990,
 - (i) the cost of components and subcomponents produced in the United States is more than 60 percent of the cost of all components of the facility or equipment, and
 - (ii) final assembly of the facility or equipment has occurred in the United States.

The FAA must grant waivers for any items that are included in these above exceptions. Bidders can review items already approved under the FAA nationwide approved list of "Equipment Meeting Buy American Requirements" on the FAA website, which do not require a specific FAA waiver.

All waivers are the responsibility of the Contractor, must be obtained prior to the Notice to Proceed, and must be submitted to the Illinois Division of Aeronautics for review and approval before being forwarded to the FAA. Any products used on the project that cannot meet the domestic requirement, and for which a waiver prior to the Notice to Proceed was not obtained, will be rejected for use and subject to removal and replacement with no additional compensation, and the contractor deemed non-responsive.

A5 CIVIL RIGHTS - GENERAL

A5.1 CONTRACT CLAUSE

GENERAL CIVIL RIGHTS PROVISIONS

The contractor agrees to comply with pertinent statutes, Executive Orders and such rules as are promulgated to ensure that no person shall, on the grounds of race, creed, color, national origin, sex, age, or disability be excluded from participating in any activity conducted with or benefiting from Federal assistance.

This provision binds the contractor and subtier contractors from the bid solicitation period through the completion of the contract. This provision is in addition to that required of Title VI of the Civil Rights Act of 1964.

A6 CIVIL RIGHTS – TITLE VI ASSURANCE

A6.1 CONTRACT CLAUSE

A6.1.1 Title VI Solicitation Notice

Title VI Solicitation Notice:

The Village of Rantoul, in accordance with the provisions of Title VI of the Civil Rights Act of 1964 (78 Stat. 252, 42 U.S.C. §§ 2000d to 2000d-4) and the Regulations, hereby notifies all bidders that it will affirmatively ensure that any contract entered into pursuant to this advertisement, disadvantaged business enterprises will be afforded full and fair opportunity to submit bids in response to this invitation and will not be discriminated against on the grounds of race, color, or national origin in consideration for an award.

A6.1.2 Title VI Clauses for Compliance with Nondiscrimination Requirements

Compliance with Nondiscrimination Requirements

During the performance of this contract, the contractor, for itself, its assignees, and successors in interest (hereinafter referred to as the "contractor") agrees as follows:

Compliance with Regulations: The contractor (hereinafter includes consultants) will comply with the Title VI List of Pertinent Nondiscrimination Acts And Authorities, as they may be amended from time to time, which are herein incorporated by reference and made a part of this contract.

Non-discrimination: The contractor, with regard to the work performed by it during the contract, will not discriminate on the grounds of race, color, or national origin in the selection and retention of subcontractors, including procurements of materials and leases of equipment. The contractor will not participate directly or indirectly in the discrimination prohibited by the Nondiscrimination Acts and Authorities, including employment practices when the contract covers any activity, project, or program set forth in Appendix B of 49 CFR part 21.

Solicitations for Subcontracts, Including Procurements of Materials and Equipment: In all solicitations, either by competitive bidding, or negotiation made by the contractor for work to be performed under a subcontract, including procurements of materials, or leases of equipment, each potential subcontractor or supplier will be notified by the contractor of the contractor's obligations under this contract and the Nondiscrimination Acts And Authorities on the grounds of race, color, or national origin.

Information and Reports: The contractor will provide all information and reports required by the Acts, the Regulations, and directives issued pursuant thereto and will permit access to its books, records, accounts, other sources of information, and its facilities as may be determined by the sponsor or the Federal Aviation Administration to be pertinent to ascertain compliance with such Nondiscrimination Acts And Authorities and instructions. Where any information required of a contractor is in the exclusive possession of another who fails or refuses to furnish the information, the contractor will so certify to the sponsor or the Federal Aviation Administration, as appropriate, and will set forth what efforts it has made to obtain the information.

Sanctions for Noncompliance: In the event of a contractor's noncompliance with the Non-discrimination provisions of this contract, the sponsor will impose such contract sanctions as it or the Federal Aviation Administration may determine to be appropriate, including, but not limited to:

- a. Withholding payments to the contractor under the contract until the contractor complies; and/or
- b. Cancelling, terminating, or suspending a contract, in whole or in part.

Incorporation of Provisions: The contractor will include the provisions of paragraphs one through six in every subcontract, including procurements of materials and leases of equipment, unless exempt by the Acts, the Regulations and directives issued pursuant thereto. The contractor will take action with respect to any subcontract or procurement as the sponsor or the Federal Aviation Administration may direct as a means of enforcing such provisions including sanctions for noncompliance. Provided, that if the contractor becomes involved in, or is threatened with litigation by a subcontractor, or supplier because of such direction, the contractor may request the sponsor to enter into any litigation to protect the interests of the sponsor. In addition, the contractor may request the United States to enter into the litigation to protect the interests of the United States.

A6.1.3 Title VI List of Pertinent Nondiscrimination Acts and Authorities

Title VI List of Pertinent Nondiscrimination Acts and Authorities

During the performance of this contract, the contractor, for itself, its assignees, and successors in interest (hereinafter referred to as the "contractor") agrees to comply with the following non-discrimination statutes and authorities; including but not limited to:

- Title VI of the Civil Rights Act of 1964 (42 U.S.C. § 2000d *et seq.*, 78 stat. 252), (prohibits discrimination on the basis of race, color, national origin); 49 CFR part 21 (Non-discrimination In Federally-Assisted Programs of The Department of Transportation—Effectuation of Title VI of The Civil Rights Act of 1964);
- The Uniform Relocation Assistance and Real Property Acquisition Policies Act of 1970, (42 U.S.C. § 4601), (prohibits unfair treatment of persons displaced or whose property has been acquired because of Federal or Federal-aid programs and projects);
- Section 504 of the Rehabilitation Act of 1973, (29 U.S.C. § 794 *et seq.*), as amended, (prohibits discrimination on the basis of disability); and 49 CFR part 27;
- The Age Discrimination Act of 1975, as amended, (42 U.S.C. § 6101 *et seq.*), (prohibits discrimination on the basis of age);
- Airport and Airway Improvement Act of 1982, (49 USC § 471, Section 47123), as amended, (prohibits discrimination based on race, creed, color, national origin, or sex);
- The Civil Rights Restoration Act of 1987, (PL 100-209), (Broadened the scope, coverage and applicability of Title VI of the Civil Rights Act of 1964, The Age Discrimination Act of 1975 and Section 504 of the Rehabilitation Act of 1973, by expanding the definition of the terms "programs or activities" to include all of the programs or activities of the Federal-aid recipients, sub-recipients and contractors, whether such programs or activities are Federally funded or not);
- Titles II and III of the Americans with Disabilities Act of 1990, which prohibit discrimination on the basis of disability in the operation of public entities, public and private transportation systems, places of public accommodation, and certain testing entities (42 U.S.C. §§ 12131 – 12189) as implemented by Department of Transportation regulations at 49 CFR parts 37 and 38;
- The Federal Aviation Administration's Non-discrimination statute (49 U.S.C. § 47123) (prohibits discrimination on the basis of race, color, national origin, and sex);
- Executive Order 12898, Federal Actions to Address Environmental Justice in Minority Populations and Low-Income Populations, which ensures non-discrimination against minority populations by discouraging programs, policies, and activities with disproportionately high and adverse human health or environmental effects on minority and low-income populations;
- Executive Order 13166, Improving Access to Services for Persons with Limited English Proficiency, and resulting agency guidance, national origin discrimination includes discrimination because of limited English proficiency (LEP). To ensure compliance with Title VI, you must take reasonable steps to ensure that LEP persons have meaningful access to your programs (70 Fed. Reg. at 74087 to 74100);
- Title IX of the Education Amendments of 1972, as amended, which prohibits you from discriminating because of sex in education programs or activities (20 U.S.C. 1681 *et seq.*).

A7 CLEAN AIR AND WATER POLLUTION CONTROL

A7.1 CONTRACT CLAUSE

This provision is required for all contracts and lower tier contracts that exceed \$150,000.

CLEAN AIR AND WATER POLLUTION CONTROL

Contractor agrees to comply with all applicable standards, orders, and regulations issued pursuant to the Clean Air Act (42 U.S.C. § 740-7671q) and the Federal Water Pollution Control Act as amended (33 U.S.C. § 1251-1387). The Contractor agrees to report any violation to the Owner immediately upon discovery. The Owner assumes responsibility for notifying the Environmental Protection Agency (EPA) and the Federal Aviation Administration.

Contractor must include this requirement in all subcontracts that exceeds \$150,000.

A8 CONTRACT WORKHOURS AND SAFETY STANDARDS ACT REQUIREMENTS

A8.1 CONTRACT CLAUSE

This provision applies to all contracts and lower tier contracts that exceed \$100,000, and employ laborers, mechanics, watchmen, and guards.

CONTRACT WORKHOURS AND SAFETY STANDARDS ACT REQUIREMENTS

1. Overtime Requirements.

No contractor or subcontractor contracting for any part of the contract work which may require or involve the employment of laborers or mechanics shall require or permit any such laborer or mechanic, including watchmen and guards, in any workweek in which he or she is employed on such work to work in excess of forty hours in such workweek unless such laborer or mechanic receives compensation at a rate not less than one and one-half times the basic rate of pay for all hours worked in excess of forty hours in such workweek.

2. Violation; Liability for Unpaid Wages; Liquidated Damages.

In the event of any violation of the clause set forth in paragraph (1) of this clause, the contractor and any subcontractor responsible therefor shall be liable for the unpaid wages. In addition, such contractor and subcontractor shall be liable to the United States (in the case of work done under contract for the District of Columbia or a territory, to such District or to such territory), for liquidated damages. Such liquidated damages shall be computed with respect to each individual laborer or mechanic, including watchmen and guards, employed in violation of the clause set forth in paragraph (1) of this clause, in the sum of \$10 for each calendar day on which such individual was required or permitted to work in excess of the standard workweek of forty hours without payment of the overtime wages required by the clause set forth in paragraph (1) of this clause.

3. Withholding for Unpaid Wages and Liquidated Damages.

The Federal Aviation Administration (FAA) or the Owner shall upon its own action or upon written request of an authorized representative of the Department of Labor withhold or cause to be withheld, from any moneys payable on account of work performed by the contractor or subcontractor under any such contract or any other Federal contract with the same prime contractor, or any other Federally-assisted contract subject to the Contract Work Hours and Safety Standards Act, which is held by the same prime contractor, such sums as may be determined to be necessary to satisfy any liabilities of such contractor or subcontractor for unpaid wages and liquidated damages as provided in the clause set forth in paragraph 2 of this clause.

4. Subcontractors.

The contractor or subcontractor shall insert in any subcontracts the clauses set forth in paragraphs (1) through (4) and also a clause requiring the subcontractor to include these clauses in any lower tier subcontracts. The prime contractor shall be responsible for compliance by any subcontractor or lower tier subcontractor with the clauses set forth in paragraphs (1) through (4) of this clause.

A9 COPELAND "ANTI-KICKBACK" ACT

A9.1 CONTRACT CLAUSE

COPELAND "ANTI-KICKBACK" ACT

Contractor must comply with the requirements of the Copeland "Anti-Kickback" Act (18 U.S.C. 874 and 40 U.S.C. 3145), as supplemented by Department of Labor regulation 29 CFR part 3. Contractor and subcontractors are prohibited from inducing, by any means, any person employed on the project to give up any part of the compensation to which the employee is entitled. The Contractor and each Subcontractor must submit to the Owner, a weekly statement on the wages paid to each employee performing on covered work during the prior week. Owner must report any violations of the Act to the Federal Aviation Administration.

A10 DAVIS-BACON REQUIREMENTS

A10.1 CONTRACT CLAUSE

DAVIS-BACON REQUIREMENTS

1. Minimum Wages

(i) All laborers and mechanics employed or working upon the site of the work will be paid unconditionally and not less often than once a week, and without subsequent deduction or rebate on any account (except such payroll deductions as are permitted by the Secretary of Labor under the Copeland Act (29 CFR Part 3)), the full amount of wages and bona fide fringe benefits (or cash equivalent thereof) due at time of payment computed at rates not less than those contained in the wage determination of the Secretary of Labor which is attached hereto and made a part hereof, regardless of any contractual relationship which may be alleged to exist between the contractor and such laborers and mechanics.

Contributions made or costs reasonably anticipated for bona fide fringe benefits under section 1(b)(2) of the Davis-Bacon Act on behalf of laborers or mechanics are considered wages paid to such laborers or mechanics, subject to the provisions of paragraph (1)(iv) of this section; also, regular contributions made or costs incurred for more than a weekly period (but not less often than quarterly) under plans, funds, or programs which cover the particular weekly period, are deemed to be constructively made or incurred during such weekly period. Such laborers and mechanics shall be paid the appropriate wage rate and fringe benefits on the wage determination for the classification of work actually performed, without regard to skill, except as provided in 29 CFR Part 5.5(a)(4). Laborers or mechanics performing work in more than one classification may be compensated at the rate specified for each classification for the time actually worked therein: *Provided*, that the employer's payroll records accurately set forth the time spent in each classification in which work is performed. The wage determination (including any additional classification and wage rates conformed under (1)(ii) of this

section) and the Davis-Bacon poster (WH-1321) shall be posted at all times by the contractor and its subcontractors at the site of the work in a prominent and accessible place where it can easily be seen by the workers.

(ii)(A) The contracting officer shall require that any class of laborers or mechanics, including helpers, which is not listed in the wage determination and which is to be employed under the contract shall be classified in conformance with the wage determination. The contracting officer shall approve an additional classification and wage rate and fringe benefits therefore only when the following criteria have been met:

(1) The work to be performed by the classification requested is not performed by a classification in the wage determination; and

(2) The classification is utilized in the area by the construction industry; and

(3) The proposed wage rate, including any bona fide fringe benefits, bears a reasonable relationship to the wage rates contained in the wage determination.

(B) If the contractor and the laborers and mechanics to be employed in the classification (if known), or their representatives, and the contracting officer agree on the classification and wage rate (including the amount designated for fringe benefits where appropriate), a report of the action taken shall be sent by the contracting officer to the Administrator of the Wage and Hour Division, Employment Standards Administration, U.S. Department of Labor, Washington, D.C. 20210. The Administrator, or an authorized representative, will approve, modify, or disapprove every additional classification action within 30 days of receipt and so advise the contracting officer or will notify the contracting officer within the 30-day period that additional time is necessary.

(C) In the event the contractor, the laborers or mechanics to be employed in the classification or their representatives, and the contracting officer do not agree on the proposed classification and wage rate (including the amount designated for fringe benefits where appropriate), the contracting officer shall refer the questions, including the views of all interested parties and the recommendation of the contracting officer, to the Administrator for determination. The Administrator, or an authorized representative, will issue a determination within 30 days of receipt and so advise the contracting officer or will notify the contracting officer within the 30-day period that additional time is necessary.

(D) The wage rate (including fringe benefits where appropriate) determined pursuant to subparagraphs (1)(ii) (B) or (C) of this paragraph, shall be paid to all workers performing work in the classification under this contract from the first day on which work is performed in the classification.

(iii) Whenever the minimum wage rate prescribed in the contract for a class of laborers or mechanics includes a fringe benefit which is not expressed as an hourly rate, the contractor shall either pay the benefit as stated in the wage determination or shall pay another bona fide fringe benefit or an hourly cash equivalent thereof.

(iv) If the contractor does not make payments to a trustee or other third person, the contractor may consider as part of the wages of any laborer or mechanic the amount of any costs reasonably anticipated in providing bona fide fringe benefits under a plan or program, *Provided*, That the Secretary of Labor has found, upon the written request of the contractor, that the applicable standards of the Davis-Bacon Act have been met. The Secretary of Labor may require the contractor to set aside in a separate account assets for the meeting of obligations under the plan or program.

2 Withholding.

The Federal Aviation Administration or the sponsor shall upon its own action or upon written request of an authorized representative of the Department of Labor withhold or cause to be withheld from the contractor under this contract or any other Federal contract with the same prime contractor, or any other Federally-assisted contract subject to Davis-Bacon prevailing wage requirements, which is held by the same prime contractor, so much of the accrued payments or advances as may be considered necessary to pay laborers and mechanics, including apprentices, trainees, and helpers, employed by the contractor or any subcontractor the full amount of wages required by the contract. In the event of failure to pay any laborer or mechanic, including any apprentice, trainee, or helper, employed or working on the site of work, all or part of the wages required by the contract, the Federal Aviation Administration may, after written notice to the contractor, sponsor, applicant, or owner, take such action as may be necessary to cause the suspension of any further payment, advance, or guarantee of funds until such violations have ceased.

3. Payrolls and basic records.

(i) Payrolls and basic records relating thereto shall be maintained by the contractor during the course of the work and preserved for a period of three years thereafter for all laborers and mechanics working at the site of the work. Such records shall contain the name, address, and social security number of each such worker, his or her correct classification, hourly rates of wages paid (including rates of contributions or costs anticipated for bona fide fringe benefits or cash equivalents thereof of the types described in 1(b)(2)(B) of the Davis-Bacon Act), daily and weekly number of hours worked, deductions made and actual wages paid. Whenever the Secretary of Labor has found under 29 CFR 5.5(a)(1)(iv) that the wages of any laborer or mechanic include the amount of any costs reasonably anticipated in providing benefits under a plan or program described in section 1(b)(2)(B) of the Davis-Bacon Act, the contractor shall maintain records which show that the commitment to provide such benefits is enforceable, that the plan or program is financially responsible, and that the plan or program has been communicated in writing to the laborers or mechanics affected, and records which show the costs anticipated or the actual costs incurred in providing such benefits. Contractors employing apprentices or trainees under approved programs shall maintain written evidence of the registration of apprenticeship programs and certification of trainee programs, the registration of the apprentices and trainees, and the ratios and wage rates prescribed in the applicable programs.

(ii)(A) The contractor shall submit weekly for each week in which any contract work is performed a copy of all payrolls to the Federal Aviation Administration if the agency is a party to the contract, but if the agency is not such a party, the contractor will submit the payrolls to the applicant, sponsor, or owner, as the case may be, for transmission to the Federal Aviation Administration. The payrolls submitted shall set out accurately and completely all of the information required to be maintained under 29 CFR 5.5(a)(3)(i), except that full social security numbers and home addresses shall not be included on weekly transmittals. Instead the payrolls shall only need to include an individually identifying number for each employee (e.g., the last four digits of the employee's social security number). The required weekly payroll information may be submitted in any form desired. Optional Form WH-347 is available for this purpose from the Wage and Hour Division Web site at <http://www.dol.gov/esa/whd/forms/wh347instr.htm> or its successor site. The prime contractor is responsible for the submission of copies of payrolls by all subcontractors. Contractors and subcontractors shall maintain the full social security number and current address of each covered worker, and shall provide them upon request to the Federal Aviation

Administration if the agency is a party to the contract, but if the agency is not such a party, the contractor will submit them to the applicant, sponsor, or owner, as the case may be, for transmission to the Federal Aviation Administration, the contractor, or the Wage and Hour Division of the Department of Labor for purposes of an investigation or audit of compliance with prevailing wage requirements. It is not a violation of this section for a prime contractor to require a subcontractor to provide addresses and social security numbers to the prime contractor for its own records, without weekly submission to the sponsoring government agency (or the applicant, sponsor, or owner).

(B) Each payroll submitted shall be accompanied by a "Statement of Compliance," signed by the contractor or subcontractor or his or her agent who pays or supervises the payment of the persons employed under the contract and shall certify the following:

(1) That the payroll for the payroll period contains the information required to be provided under 29 CFR § 5.5(a)(3)(ii), the appropriate information is being maintained under 29 CFR § 5.5 (a)(3)(i) and that such information is correct and complete;

(2) That each laborer and mechanic (including each helper, apprentice and trainee) employed on the contract during the payroll period has been paid the full weekly wages earned, without rebate, either directly or indirectly, and that no deductions have been made either directly or indirectly from the full wages earned, other than permissible deductions as set forth in Regulations 29 CFR Part 3;

(3) That each laborer or mechanic has been paid not less than the applicable wage rates and fringe benefits or cash equivalents for the classification of work performed, as specified in the applicable wage determination incorporated into the contract.

(C) The weekly submission of a properly executed certification set forth on the reverse side of Optional Form WH-347 shall satisfy the requirement for submission of the "Statement of Compliance" required by paragraph (3)(ii)(B) of this section.

(D) The falsification of any of the above certifications may subject the contractor or subcontractor to civil or criminal prosecution under Section 1001 of Title 18 and Section 231 of Title 31 of the United States Code.

(iii) The contractor or subcontractor shall make the records required under paragraph (3)(i) of this section available for inspection, copying or transcription by authorized representatives of the sponsor, the Federal Aviation Administration or the Department of Labor, and shall permit such representatives to interview employees during working hours on the job. If the contractor or subcontractor fails to submit the required records or to make them available, the Federal agency may, after written notice to the contractor, sponsor, applicant or owner, take such action as may be necessary to cause the suspension of any further payment, advance, or guarantee of funds. Furthermore, failure to submit the required records upon request or to make such records available may be grounds for debarment action pursuant to 29 CFR 5.12.

4. Apprentices and Trainees.

(i) Apprentices. Apprentices will be permitted to work at less than the predetermined rate for the work they performed when they are employed pursuant to and individually registered in a bona fide apprenticeship program registered with the U.S. Department of Labor, Employment and Training Administration, Bureau of Apprenticeship and Training, or with a State Apprenticeship Agency recognized by the Bureau, or if a person is employed in his or her first 90 days of probationary employment as an apprentice in such an apprenticeship program, who is not individually registered in the program, but who has been certified by the Bureau of Apprenticeship and Training or a State Apprenticeship Agency (where appropriate) to be eligible for probationary employment as an apprentice. The allowable ratio of apprentices to journeymen on the job site in any craft classification shall not be greater than the ratio permitted to the contractor as to the entire work force under the registered program. Any worker listed on a payroll at an apprentice wage rate, who is not registered or otherwise employed as stated above, shall be paid not less than the applicable wage rate on the wage determination for the classification of work actually performed. In addition, any apprentice performing work on the job site in excess of the ratio permitted under the registered program shall be paid not less than the applicable wage rate on the wage determination for the work actually performed. Where a contractor is performing construction on a project in a locality other than that in which its program is registered, the ratios and wage rates (expressed in percentages of the journeyman's hourly rate) specified in the contractor's or subcontractor's registered program shall be observed. Every apprentice must be paid at not less than the rate specified in the registered program for the apprentice's level of progress, expressed as a percentage of the journeymen hourly rate specified in the applicable wage determination. Apprentices shall be paid fringe benefits in accordance with the provisions of the apprenticeship program. If the apprenticeship program does not specify fringe benefits, apprentices must be paid the full amount of fringe benefits listed on the wage determination for the applicable classification. If the Administrator determines that a different practice prevails for the applicable apprentice classification, fringes shall be paid in accordance with that determination. In the event the Bureau of Apprenticeship and Training, or a State Apprenticeship Agency recognized by the Bureau, withdraws approval of an apprenticeship program, the contractor will no longer be permitted to utilize apprentices at less than the applicable predetermined rate for the work performed until an acceptable program is approved.

(ii) Trainees. Except as provided in 29 CFR 5.16, trainees will not be permitted to work at less than the predetermined rate for the work performed unless they are employed pursuant to and individually registered in a program which has received prior approval, evidenced by formal certification by the U.S. Department of Labor, Employment and Training Administration. The ratio of trainees to journeymen on the job site shall not be greater than permitted under the plan approved by the Employment and Training Administration. Every trainee must be paid at not less than the rate specified in the approved program for the trainee's level of progress, expressed as a percentage of the journeyman hourly rate specified in the applicable wage determination. Trainees shall be paid fringe benefits in accordance with the provisions of the trainee program. If the trainee program does not mention fringe benefits, trainees shall be paid the full amount of fringe benefits listed on the wage determination unless the Administrator of the Wage and Hour Division determines that there is an apprenticeship program associated with the corresponding journeyman wage rate on the wage determination which provides for less than full fringe benefits for apprentices. Any employee listed on the payroll at a trainee rate that is not registered and participating in a training plan approved by the Employment and Training Administration shall be paid not less than the applicable wage rate on the wage determination for the classification of work actually performed. In addition, any trainee performing work on the job site in excess of the ratio permitted under the registered program shall be paid not less than the applicable wage rate on the wage determination for the work actually performed. In the event the Employment and Training Administration withdraws approval of a training program, the contractor will no longer be permitted to utilize trainees at less than the applicable predetermined rate for the work performed until an acceptable program is approved.

(iii) Equal Employment Opportunity. The utilization of apprentices, trainees and journeymen under this part shall be in conformity with the equal employment opportunity requirements of Executive Order 11246, as amended, and 29 CFR Part 30.

5. Compliance with Copeland Act Requirements.

The contractor shall comply with the requirements of 29 CFR Part 3, which are incorporated by reference in this contract.

6. Subcontracts.

The contractor or subcontractor shall insert in any subcontracts the clauses contained in 29 CFR Part 5.5(a)(1) through (10) and such other clauses as the Federal Aviation Administration may by appropriate instructions require, and also a clause requiring the subcontractors to include these clauses in any lower tier subcontracts. The prime contractor shall be responsible for the compliance by any subcontractor or lower tier subcontractor with all the contract clauses in 29 CFR Part 5.5.

7. Contract Termination: Debarment.

A breach of the contract clauses in paragraph 1 through 10 of this section may be grounds for termination of the contract, and for debarment as a contractor and a subcontractor as provided in 29 CFR 5.12.

8. Compliance With Davis-Bacon and Related Act Requirements.

All rulings and interpretations of the Davis-Bacon and Related Acts contained in 29 CFR Parts 1, 3, and 5 are herein incorporated by reference in this contract.

9. Disputes Concerning Labor Standards.

Disputes arising out of the labor standards provisions of this contract shall not be subject to the general disputes clause of this contract. Such disputes shall be resolved in accordance with the procedures of the Department of Labor set forth in 29 CFR Parts 5, 6 and 7. Disputes within the meaning of this clause include disputes between the contractor (or any of its subcontractors) and the contracting agency, the U.S. Department of Labor, or the employees or their representatives.

10. Certification of Eligibility.

(i) By entering into this contract, the contractor certifies that neither it (nor he or she) nor any person or firm who has an interest in the contractor's firm is a person or firm ineligible to be awarded Government contracts by virtue of section 3(a) of the Davis-Bacon Act or 29 CFR 5.12(a)(1).

(ii) No part of this contract shall be subcontracted to any person or firm ineligible for award of a Government contract by virtue of section 3(a) of the Davis-Bacon Act or 29 CFR 5.12(a)(1).

(iii) The penalty for making false statements is prescribed in the U.S. Criminal Code, 18 U.S.C. 1001.

A11 DEBARMENT AND SUSPENSION

A11.1 CONTRACT CLAUSE

A11.1.1 Bidder or Offeror Certification

CERTIFICATION OF OFFERER/BIDDER REGARDING DEBARMENT

By submitting a bid/proposal under this solicitation, the bidder or offeror certifies that neither it nor its principals are presently debarred or suspended by any Federal department or agency from participation in this transaction.

A11.1.2 Lower Tier Contract Certification

CERTIFICATION OF LOWER TIER CONTRACTORS REGARDING DEBARMENT

The successful bidder, by administering each lower tier subcontract that exceeds \$25,000 as a "covered transaction", must verify each lower tier participant of a "covered transaction" under the project is not presently debarred or otherwise disqualified from participation in this federally assisted project. The successful bidder will accomplish this by:

1. Checking the System for Award Management at website: <http://www.sam.gov>
2. Collecting a certification statement similar to the Certificate Regarding Debarment and Suspension (Bidder or Offeror), above.
3. Inserting a clause or condition in the covered transaction with the lower tier contract

If the FAA later determines that a lower tier participant failed to disclose to a higher tier participant that it was excluded or disqualified at the time it entered the covered transaction, the FAA may pursue any available remedies, including suspension and debarment of the non-compliant participant.

A12 DISADVANTAGED BUSINESS ENTERPRISE

A12.1 REQUIRED PROVISIONS

A12.1.1 Solicitation Language (Solicitations that include a Project Goal)

The Owner's award of this contract is conditioned upon Bidder or Offeror satisfying the good faith effort requirements of 49 CFR §26.53.

As a condition of bid responsiveness, the Bidder or Offeror must submit the following information with their proposal on the forms provided herein:

- (1) The names and addresses of Disadvantaged Business Enterprise (DBE) firms that will participate in the contract;
- (2) A description of the work that each DBE firm will perform;
- (3) The dollar amount of the participation of each DBE firm listed under (1)
- (4) Written statement from Bidder or Offeror that attests their commitment to use the DBE firm(s) listed under (1) to meet the Owner's project goal;
- (5) If Bidder or Offeror cannot meet the advertised project DBE goal; evidence of good faith efforts undertaken by the Bidder or Offeror as described in appendix A to 49 CFR Part 26.

A12.1.2 Solicitation Language (Race/Gender Neutral Means)

The requirements of 49 CFR part 26 apply to this contract. It is the policy of the Village of Rantoul to practice nondiscrimination based on race, color, sex or national origin in the award or performance of this contract. The Owner encourages participation by all firms qualifying under this solicitation regardless of business size or ownership.

A12.1.3 Prime Contracts (Projects covered by DBE Program)

DISADVANTAGED BUSINESS ENTERPRISES

Contract Assurance (§ 26.13) - The Contractor or subcontractor shall not discriminate on the basis of race, color, national origin, or sex in the performance of this contract. The Contractor shall carry out applicable requirements of 49 CFR part 26 in the award and administration of Department of Transportation-assisted contracts. Failure by the Contractor to carry out these requirements is a material breach of this contract, which may result in the termination of this contract or such other remedy as the Owner deems appropriate, which may include, but is not limited to:

- 1) Withholding monthly progress payments;
- 2) Assessing sanctions;
- 3) Liquidated damages; and/or
- 4) Disqualifying the Contractor from future bidding as non-responsible.

A13 DISTRACTED DRIVING

A13.1 CONTRACT CLAUSE

TEXTING WHEN DRIVING

In accordance with Executive Order 13513, "Federal Leadership on Reducing Text Messaging While Driving" (10/1/2009) and DOT Order 3902.10 "Text Messaging While Driving" (12/30/2009), the FAA encourages recipients of Federal grant funds to adopt and enforce safety policies that decrease crashes by distracted drivers, including policies to ban text messaging while driving when performing work related to a grant or sub-grant.

In support of this initiative, the Owner encourages the Contractor to promote policies and initiatives for its employees and other work personnel that decrease crashes by distracted drivers, including policies that ban text messaging while driving motor vehicles while performing work activities associated with the project. The Contractor must include the substance of this clause in all sub-tier contracts exceeding \$3,500 and involve driving a motor vehicle in performance of work activities associated with the project.

A14 ENERGY CONSERVATION REQUIREMENTS

A14.1 CONTRACT CLAUSE

ENERGY CONSERVATION REQUIREMENTS

Contractor and Subcontractor agree to comply with mandatory standards and policies relating to energy efficiency as contained in the state energy conservation plan issued in compliance with the Energy Policy and Conservation Act (42 U.S.C. 6201 *et seq.*).

A15 EQUAL EMPLOYMENT OPPORTUNITY (E.E.O.)

A15.1 MANDATORY CONTRACT CLAUSE

A15.1.1 E.E.O. Contract Clause

EQUAL OPPORTUNITY CLAUSE

During the performance of this contract, the contractor agrees as follows:

- (1) The contractor will not discriminate against any employee or applicant for employment because of race, color, religion, sex, or national origin. The contractor will take affirmative action to ensure that applicants are employed, and that employees are treated during employment without regard to their race, color, religion, sex, sexual orientation, gender identify or national origin. Such action shall include, but not be limited to the following: employment, upgrading, demotion, or transfer; recruitment or recruitment advertising; layoff or termination; rates of pay or other forms of compensation; and selection for training, including apprenticeship. The contractor agrees to post in conspicuous places, available to employees and applicants for employment, notices to be provided setting forth the provisions of this nondiscrimination clause.

(2) The contractor will, in all solicitations or advertisements for employees placed by or on behalf of the contractor, state that all qualified applicants will receive considerations for employment without regard to race, color, religion, sex, or national origin.

(3) The contractor will send to each labor union or representative of workers with which he has a collective bargaining agreement or other contract or understanding, a notice to be provided advising the said labor union or workers' representatives of the contractor's commitments under this section, and shall post copies of the notice in conspicuous places available to employees and applicants for employment.

(4) The contractor will comply with all provisions of Executive Order 11246 of September 24, 1965, and of the rules, regulations, and relevant orders of the Secretary of Labor.

(5) The contractor will furnish all information and reports required by Executive Order 11246 of September 24, 1965, and by rules, regulations, and orders of the Secretary of Labor, or pursuant thereto, and will permit access to his books, records, and accounts by the administering agency and the Secretary of Labor for purposes of investigation to ascertain compliance with such rules, regulations, and orders.

(6) In the event of the contractor's noncompliance with the nondiscrimination clauses of this contract or with any of the said rules, regulations, or orders, this contract may be canceled, terminated, or suspended in whole or in part and the contractor may be declared ineligible for further Government contracts or federally assisted construction contracts in accordance with procedures authorized in Executive Order 11246 of September 24, 1965, and such other sanctions may be imposed and remedies invoked as provided in Executive Order 11246 of September 24, 1965, or by rule, regulation, or order of the Secretary of Labor, or as otherwise provided by law.

(7) The contractor will include the portion of the sentence immediately preceding paragraph (1) and the provisions of paragraphs (1) through (7) in every subcontract or purchase order unless exempted by rules, regulations, or orders of the Secretary of Labor issued pursuant to section 204 of Executive Order 11246 of September 24, 1965, so that such provisions will be binding upon each subcontractor or vendor. The contractor will take such action with respect to any subcontract or purchase order as the administering agency may direct as a means of enforcing such provisions, including sanctions for noncompliance: *Provided, however,* That in the event a contractor becomes involved in, or is threatened with, litigation with a subcontractor or vendor as a result of such direction by the administering agency the contractor may request the United States to enter into such litigation to protect the interests of the United States.

A15.1.2 EEO Specification

STANDARD FEDERAL EQUAL EMPLOYMENT OPPORTUNITY CONSTRUCTION CONTRACT SPECIFICATIONS

1. As used in these specifications:

- a. "Covered area" means the geographical area described in the solicitation from which this contract resulted;
- b. "Director" means Director, Office of Federal Contract Compliance Programs (OFCCP), U.S. Department of Labor, or any person to whom the Director delegates authority;
- c. "Employer identification number" means the Federal social security number used on the Employer's Quarterly Federal Tax Return, U.S. Treasury Department Form 941;
- d. "Minority" includes:
 - (1) Black (all) persons having origins in any of the Black African racial groups not of Hispanic origin);
 - (2) Hispanic (all persons of Mexican, Puerto Rican, Cuban, Central or South American, or other Spanish culture or origin regardless of race);
 - (3) Asian and Pacific Islander (all persons having origins in any of the original peoples of the Far East, Southeast Asia, the Indian Subcontinent, or the Pacific Islands); and
 - (4) American Indian or Alaskan native (all persons having origins in any of the original peoples of North America and maintaining identifiable tribal affiliations through membership and participation or community identification).

2. Whenever the contractor, or any subcontractor at any tier, subcontracts a portion of the work involving any construction trade, it shall physically include in each subcontract in excess of \$10,000 the provisions of these specifications and the Notice which contains the applicable goals for minority and female participation and which is set forth in the solicitations from which this contract resulted.

3. If the contractor is participating (pursuant to 41 CFR 60-4.5) in a Hometown Plan approved by the U.S. Department of Labor in the covered area either individually or through an association, its affirmative action obligations on all work in the Plan area (including goals and timetables) shall be in accordance with that Plan for those trades which have unions participating in the Plan. Contractors shall be able to demonstrate their participation in and compliance with the provisions of any such Hometown Plan. Each contractor or subcontractor participating in an approved plan is individually required to comply with its obligations under the EEO clause and to make a good faith effort to achieve each goal under the Plan in each trade in which it has employees. The overall good faith performance by other contractors or subcontractors toward a goal in an approved Plan does not excuse any covered contractor's or subcontractor's failure to take good faith efforts to achieve the Plan goals and timetables.

4. The contractor shall implement the specific affirmative action standards provided in paragraphs 7a through 7p of these specifications. The goals set forth in the solicitation from which this contract resulted are expressed as percentages of the total hours of employment and training of minority and female utilization the contractor should reasonably be able to achieve in each construction trade in which it has employees in the covered area. Covered construction contractors performing construction work in a geographical area where they do not have a Federal or federally assisted construction contract shall apply the minority and female goals established for the geographical area where the work is being performed. Goals are published periodically in the Federal Register in notice form, and such notices may be obtained from any Office of Federal Contract Compliance

Programs office or from Federal procurement contracting officers. The contractor is expected to make substantially uniform progress in meeting its goals in each craft during the period specified.

5. Neither the provisions of any collective bargaining agreement nor the failure by a union with whom the contractor has a collective bargaining agreement to refer either minorities or women shall excuse the contractor's obligations under these specifications, Executive Order 11246 or the regulations promulgated pursuant thereto.

6. In order for the non-working training hours of apprentices and trainees to be counted in meeting the goals, such apprentices and trainees shall be employed by the contractor during the training period and the contractor shall have made a commitment to employ the apprentices and trainees at the completion of their training, subject to the availability of employment opportunities. Trainees shall be trained pursuant to training programs approved by the U.S. Department of Labor.

7. The contractor shall take specific affirmative actions to ensure equal employment opportunity. The evaluation of the contractor's compliance with these specifications shall be based upon its effort to achieve maximum results from its actions. The contractor shall document these efforts fully and shall implement affirmative action steps at least as extensive as the following:

- a. Ensure and maintain a working environment free of harassment, intimidation, and coercion at all sites, and in all facilities at which the contractor's employees are assigned to work. The contractor, where possible, will assign two or more women to each construction project. The contractor shall specifically ensure that all foremen, superintendents, and other onsite supervisory personnel are aware of and carry out the contractor's obligation to maintain such a working environment, with specific attention to minority or female individuals working at such sites or in such facilities.
- b. Establish and maintain a current list of minority and female recruitment sources, provide written notification to minority and female recruitment sources and to community organizations when the contractor or its unions have employment opportunities available, and maintain a record of the organizations' responses.
- c. Maintain a current file of the names, addresses, and telephone numbers of each minority and female off-the-street applicant and minority or female referral from a union, a recruitment source, or community organization and of what action was taken with respect to each such individual. If such individual was sent to the union hiring hall for referral and was not referred back to the contractor by the union or, if referred, not employed by the contractor, this shall be documented in the file with the reason therefore along with whatever additional actions the contractor may have taken.
- d. Provide immediate written notification to the Director when the union or unions with which the contractor has a collective bargaining agreement has not referred to the contractor a minority person or female sent by the contractor, or when the contractor has other information that the union referral process has impeded the contractor's efforts to meet its obligations.
- e. Develop on-the-job training opportunities and/or participate in training programs for the area which expressly include minorities and women, including upgrading programs and apprenticeship and trainee programs relevant to the contractor's employment needs, especially those programs funded or approved by the Department of Labor. The contractor shall provide notice of these programs to the sources compiled under 7b above.
- f. Disseminate the contractor's EEO policy by providing notice of the policy to unions and training programs and requesting their cooperation in assisting the contractor in meeting its EEO obligations; by including it in any policy manual and collective bargaining agreement; by publicizing it in the company newspaper, annual report, etc.; by specific review of the policy with all management personnel and with all minority and female employees at least once a year; and by posting the company EEO policy on bulletin boards accessible to all employees at each location where construction work is performed.
- g. Review, at least annually, the company's EEO policy and affirmative action obligations under these specifications with all employees having any responsibility for hiring, assignment, layoff, termination, or other employment decisions including specific review of these items with onsite supervisory personnel such as superintendents, general foremen, etc., prior to the initiation of construction work at any job site. A written record shall be made and maintained identifying the time and place of these meetings, persons attending, subject matter discussed, and disposition of the subject matter.
- h. Disseminate the contractor's EEO policy externally by including it in any advertising in the news media, specifically including minority and female news media, and providing written notification to and discussing the contractor's EEO policy with other contractors and subcontractors with whom the contractor does or anticipates doing business.
- i. Direct its recruitment efforts, both oral and written, to minority, female, and community organizations, to schools with minority and female students; and to minority and female recruitment and training organizations serving the contractor's recruitment area and employment needs. Not later than one month prior to the date for the acceptance of applications for apprenticeship or other training by any recruitment source, the contractor shall send written notification to organizations, such as the above, describing the openings, screening procedures, and tests to be used in the selection process.
- j. Encourage present minority and female employees to recruit other minority persons and women and, where reasonable, provide after school, summer, and vacation employment to minority and female youth both on the site and in other areas of a contractor's workforce.
- k. Validate all tests and other selection requirements where there is an obligation to do so under 41 CFR Part 60-3.
- l. Conduct, at least annually, an inventory and evaluation at least of all minority and female personnel, for promotional opportunities and encourage these employees to seek or to prepare for, through appropriate training, etc., such opportunities.
- m. Ensure that seniority practices, job classifications, work assignments, and other personnel practices do not have a discriminatory effect by continually monitoring all personnel and employment related activities to ensure that the EEO policy and the contractor's obligations under these specifications are being carried out.

- n. Ensure that all facilities and company activities are non-segregated except that separate or single user toilet and necessary changing facilities shall be provided to assure privacy between the sexes.
- o. Document and maintain a record of all solicitations of offers for subcontracts from minority and female construction contractors and suppliers, including circulation of solicitations to minority and female contractor associations and other business associations.
- p. Conduct a review, at least annually, of all supervisor's adherence to and performance under the contractor's EEO policies and affirmative action obligations.

8. Contractors are encouraged to participate in voluntary associations, which assist in fulfilling one or more of their affirmative action obligations (7a through 7p). The efforts of a contractor association, joint contractor union, contractor community, or other similar groups of which the contractor is a member and participant, may be asserted as fulfilling any one or more of its obligations under 7a through 7p of these specifications provided that the contractor actively participates in the group, makes every effort to assure that the group has a positive impact on the employment of minorities and women in the industry, ensures that the concrete benefits of the program are reflected in the contractor's minority and female workforce participation, makes a good faith effort to meet its individual goals and timetables, and can provide access to documentation which demonstrates the effectiveness of actions taken on behalf of the contractor. The obligation to comply, however, is the contractor's and failure of such a group to fulfill an obligation shall not be a defense for the contractor's noncompliance.

9. A single goal for minorities and a separate single goal for women have been established. The contractor, however, is required to provide equal employment opportunity and to take affirmative action for all minority groups, both male and female, and all women, both minority and non-minority. Consequently, if the particular group is employed in a substantially disparate manner (for example, even though the contractor has achieved its goals for women generally,) the contractor may be in violation of the Executive Order if a specific minority group of women is underutilized.

10. The contractor shall not use the goals and timetables or affirmative action standards to discriminate against any person because of race, color, religion, sex, or national origin.

11. The contractor shall not enter into any subcontract with any person or firm debarred from Government contracts pursuant to Executive Order 11246.

12. The contractor shall carry out such sanctions and penalties for violation of these specifications and of the Equal Opportunity Clause, including suspension, termination, and cancellation of existing subcontracts as may be imposed or ordered pursuant to Executive Order 11246, as amended, and its implementing regulations, by the Office of Federal Contract Compliance Programs. Any contractor who fails to carry out such sanctions and penalties shall be in violation of these specifications and Executive Order 11246, as amended.

13. The contractor, in fulfilling its obligations under these specifications, shall implement specific affirmative action steps, at least as extensive as those standards prescribed in paragraph 7 of these specifications, so as to achieve maximum results from its efforts to ensure equal employment opportunity. If the contractor fails to comply with the requirements of the Executive Order, the implementing regulations, or these specifications, the Director shall proceed in accordance with 41 CFR 60-4.8.

14. The contractor shall designate a responsible official to monitor all employment related activity to ensure that the company EEO policy is being carried out, to submit reports relating to the provisions hereof as may be required by the Government, and to keep records. Records shall at least include for each employee, the name, address, telephone number, construction trade, union affiliation if any, employee identification number when assigned, social security number, race, sex, status (e.g., mechanic, apprentice, trainee, helper, or laborer), dates of changes in status, hours worked per week in the indicated trade, rate of pay, and locations at which the work was performed. Records shall be maintained in an easily understandable and retrievable form; however, to the degree that existing records satisfy this requirement, contractors shall not be required to maintain separate records.

15. Nothing herein provided shall be construed as a limitation upon the application of other laws which establish different standards of compliance or upon the application of requirements for the hiring of local or other area residents (e.g., those under the Public Works Employment Act of 1977 and the Community Development Block Grant Program).

A16 FEDERAL FAIR LABOR STANDARDS ACT (FEDERAL MINIMUM WAGE)

A16.1 CONTRACT CLAUSE

All contracts and subcontracts that result from this solicitation incorporate by reference the provisions of 29 CFR part 201, the Federal Fair Labor Standards Act (FLSA), with the same force and effect as if given in full text. The FLSA sets minimum wage, overtime pay, recordkeeping, and child labor standards for full and part time workers.

The contractor has full responsibility to monitor compliance to the referenced statute or regulation. The contractor must address any claims or disputes that arise from this requirement directly with the U.S. Department of Labor – Wage and Hour Division.

A17 LOBBYING AND INFLUENCING FEDERAL EMPLOYEES

A17.1 CONTRACT CLAUSE

This provision is required for all contracts that exceed \$100,000.

CERTIFICATION REGARDING LOBBYING

The bidder or offeror certifies by signing and submitting this bid or proposal, to the best of his or her knowledge and belief, that:

- (1) No Federal appropriated funds have been paid or will be paid, by or on behalf of the Bidder or Offeror, to any person for influencing or attempting to influence an officer or employee of an agency, a Member of Congress, an officer or employee of Congress, or an employee of a Member of Congress in connection with the awarding of any Federal contract, the making of any Federal grant, the making of any Federal loan, the entering into of any cooperative agreement, and the extension, continuation, renewal, amendment, or modification of any Federal contract, grant, loan, or cooperative agreement.
- (2) If any funds other than Federal appropriated funds have been paid or will be paid to any person for influencing or attempting to influence an officer or employee of any agency, a Member of Congress, an officer or employee of Congress, or an employee of a Member of Congress in connection with this Federal contract, grant, loan, or cooperative agreement, the undersigned shall complete and submit Standard Form-LLL, "Disclosure Form to Report Lobbying," in accordance with its instructions.
- (3) The undersigned shall require that the language of this certification be included in the award documents for all sub-awards at all tiers (including subcontracts, sub-grants, and contracts under grants, loans, and cooperative agreements) and that all sub-recipients shall certify and disclose accordingly.

This certification is a material representation of fact upon which reliance was placed when this transaction was made or entered into. Submission of this certification is a prerequisite for making or entering into this transaction imposed by section 1352, title 31, U.S. Code. Any person who fails to file the required certification shall be subject to a civil penalty of not less than \$10,000 and not more than \$100,000 for each such failure.

A18 PROHIBITION of SEGREGATED FACILITIES

A18.1 CONTRACT CLAUSE

PROHIBITION of SEGREGATED FACILITIES

(a) The Contractor agrees that it does not and will not maintain or provide for its employees any segregated facilities at any of its establishments, and that it does not and will not permit its employees to perform their services at any location under its control where segregated facilities are maintained. The Contractor agrees that a breach of this clause is a violation of the Equal Opportunity clause in this contract.

(b) "Segregated facilities," as used in this clause, means any waiting rooms, work areas, rest rooms and wash rooms, restaurants and other eating areas, time clocks, locker rooms and other storage or dressing areas, parking lots, drinking fountains, recreation or entertainment areas, transportation, and housing facilities provided for employees, that are segregated by explicit directive or are in fact segregated on the basis of race, color, religion, sex, or national origin because of written or oral policies or employee custom. The term does not include separate or single-user rest rooms or necessary dressing or sleeping areas provided to assure privacy between the sexes.

(c) The Contractor shall include this clause in every subcontract and purchase order that is subject to the Equal Opportunity clause of this contract.

A19 OCCUPATIONAL SAFETY AND HEALTH ACT OF 1970

A19.1 CONTRACT CLAUSE

All contracts and subcontracts that result from this solicitation incorporate by reference the requirements of 29 CFR Part 1910 with the same force and effect as if given in full text. Contractor must provide a work environment that is free from recognized hazards that may cause death or serious physical harm to the employee. The Contractor retains full responsibility to monitor its compliance and their subcontractor's compliance with the applicable requirements of the Occupational Safety and Health Act of 1970 (29 CFR Part 1910). Contractor must address any claims or disputes that pertain to a referenced requirement directly with the U.S. Department of Labor – Occupational Safety and Health Administration.

A20 PROCUREMENT OF RECOVERED MATERIALS

A20.1 CONTRACT CLAUSE

Procurement of Recovered Materials

Contractor and subcontractor agree to comply with Section 6002 of the Solid Waste Disposal Act, as amended by the Resource Conservation and Recovery Act, and the regulatory provisions of 40 CFR Part 247. In the performance of this contract and to the extent practicable, the Contractor and subcontractors are to use of products containing the highest percentage of recovered materials for items designated by the Environmental Protection Agency (EPA) under 40 CFR Part 247 whenever:

- a) The contract requires procurement of \$10,000 or more of a designated item during the fiscal year; or,

The contractor has procured \$10,000 or more of a designated item using Federal funding during the previous fiscal year.

The list of EPA-designated items is available at www.epa.gov/epawaste/conserve/tools/cpg/products/.

Section 6002(c) establishes exceptions to the preference for recovery of EPA-designated products if the contractor can demonstrate the item is:

- a) Not reasonably available within a timeframe providing for compliance with the contract performance schedule;
- b) Fails to meet reasonable contract performance requirements; or
- c) Is only available at an unreasonable price.

A21 RIGHT TO INVENTIONS

A21.1 CONTRACT CLAUSE

RIGHTS TO INVENTIONS

Contracts or agreements that include the performance of experimental, developmental, or research work must provide for the rights of the Federal Government and the Owner in any resulting invention as established by 37 CFR part 401, Rights to Inventions Made by Non-profit Organizations and Small Business Firms under Government Grants, Contracts, and Cooperative Agreements. This contract incorporates by reference the patent and inventions rights as specified within in the 37 CFR §401.14. Contractor must include this requirement in all sub-tier contracts involving experimental, developmental or research work.

A22 SEISMIC SAFETY

A22.1 CONTRACT CLAUSE

A22.1.1 Construction Contracts

Seismic Safety

The contractor agrees to ensure that all work performed under this contract, including work performed by subcontractors, conforms to a building code standard that provides a level of seismic safety substantially equivalent to standards established by the National Earthquake Hazards Reduction Program (NEHRP). Local building codes that model their code after the current version of the International Building Code (IBC) meet the NEHRP equivalency level for seismic safety.

A23 TAX DELINQUENCY AND FELONY CONVICTIONS

A23.1 CONTRACT CLAUSE

CERTIFICATION OF OFFERER/BIDDER REGARDING TAX DELINQUENCY AND FELONY CONVICTIONS

Certifications

- 1) The applicant represents that it is not a corporation that has any unpaid Federal tax liability that has been assessed, for which all judicial and administrative remedies have been exhausted or have lapsed, and that is not being paid in a timely manner pursuant to an agreement with the authority responsible for collecting the tax liability.
- 2) The applicant represents that it is not a corporation that was convicted of a criminal violation under any Federal law within the preceding 24 months.

Note

If an applicant cannot comply with either of the above representations, the applicant is ineligible to receive an award unless the sponsor has received notification from the agency suspension and debarment official (SDO) that the SDO has considered suspension or debarment and determined that further action is not required to protect the Government's interests. The applicant therefore must provide information to the owner about its tax liability or conviction to the Owner, who will then notify the FAA Airports District Office, which will then notify the agency's SDO to facilitate completion of the required considerations before award decisions are made.

The applicant agrees that, if awarded a contract resulting from this solicitation, it will incorporate this provision for certification in all lower tier subcontracts.

Term Definitions

Felony conviction: Felony conviction means a conviction within the preceding twenty-four (24) months of a felony criminal violation under any Federal law and includes conviction of an offense defined in a section of the U.S. code that specifically classifies the offense as a felony and conviction of an offense that is classified as a felony under 18 U.S.C. § 3559.

Tax Delinquency: A tax delinquency is any unpaid Federal tax liability that has been assessed, for which all judicial and administrative remedies have been exhausted, or have lapsed, and that is not being paid in a timely manner pursuant to an agreement with the authority responsible for collecting the tax liability.

A24 TERMINATION OF CONTRACT

A24.1 CONTRACT CLAUSE

A24.1.1 Termination for Convenience

Termination for Convenience (Construction & Equipment Contracts)

The Owner may terminate this contract in whole or in part at any time by providing written notice to the Contractor. Such action may be without cause and without prejudice to any other right or remedy of Owner. Upon receipt of a written notice of termination, except as explicitly directed by the Owner, the Contractor shall immediately proceed with the following obligations regardless of any delay in determining or adjusting amounts due under this clause:

1. Contractor must immediately discontinue work as specified in the written notice.
2. Terminate all subcontracts to the extent they relate to the work terminated under the notice.
3. Discontinue orders for materials and services except as directed by the written notice.
4. Deliver to the owner all fabricated and partially fabricated parts, completed and partially completed work, supplies, equipment and materials acquired prior to termination of the work and as directed in the written notice.
5. Complete performance of the work not terminated by the notice.
6. Take action as directed by the owner to protect and preserve property and work related to this contract that Owner will take possession.

Owner agrees to pay Contractor for:

- a) completed and acceptable work executed in accordance with the contract documents prior to the effective date of termination;

documented expenses sustained prior to the effective date of termination in performing work and furnishing labor, materials, or equipment as required by the contract documents in connection with uncompleted work;

reasonable and substantiated claims, costs and damages incurred in settlement of terminated contracts with Subcontractors and Suppliers; and reasonable and substantiated expenses to the contractor directly attributable to Owner's termination action

Owner will not pay Contractor for loss of anticipated profits or revenue or other economic loss arising out of or resulting from the Owner's termination action.

The rights and remedies this clause provides are in addition to any other rights and remedies provided by law or under this contract.

A24.1.2 Termination for Default

Termination for Default (Construction)

Section 80-09 of FAA Advisory Circular 150/5370-10 establishes conditions, rights and remedies associated with Owner termination of this contract due default of the Contractor.

A25 TRADE RESTRICTION CERTIFICATION

A25.1 CONTRACT CLAUSE

TRADE RESTRICTION CERTIFICATION

By submission of an offer, the Offeror certifies that with respect to this solicitation and any resultant contract, the Offeror -

- a. is not owned or controlled by one or more citizens of a foreign country included in the list of countries that discriminate against U.S. firms as published by the Office of the United States Trade Representative (U.S.T.R.);
- b. has not knowingly entered into any contract or subcontract for this project with a person that is a citizen or national of a foreign country included on the list of countries that discriminate against U.S. firms as published by the U.S.T.R; and
- c. has not entered into any subcontract for any product to be used on the Federal on the project that is produced in a foreign country included on the list of countries that discriminate against U.S. firms published by the U.S.T.R.

This certification concerns a matter within the jurisdiction of an agency of the United States of America and the making of a false, fictitious, or fraudulent certification may render the maker subject to prosecution under Title 18, United States Code, Section 1001.

The Offeror/Contractor must provide immediate written notice to the Owner if the Offeror/Contractor learns that its certification or that of a subcontractor was erroneous when submitted or has become erroneous by reason of changed circumstances. The Contractor must require subcontractors provide immediate written notice to the Contractor if at any time it learns that its certification was erroneous by reason of changed circumstances.

Unless the restrictions of this clause are waived by the Secretary of Transportation in accordance with 49 CFR 30.17, no contract shall be awarded to an Offeror or subcontractor:

- (1) who is owned or controlled by one or more citizens or nationals of a foreign country included on the list of countries that discriminate against U.S. firms published by the U.S.T.R. or
- (2) whose subcontractors are owned or controlled by one or more citizens or nationals of a foreign country on such U.S.T.R. list or

(3) who incorporates in the public works project any product of a foreign country on such U.S.T.R. list;

Nothing contained in the foregoing shall be construed to require establishment of a system of records in order to render, in good faith, the certification required by this provision. The knowledge and information of a contractor is not required to exceed that which is normally possessed by a prudent person in the ordinary course of business dealings.

The Offeror agrees that, if awarded a contract resulting from this solicitation, it will incorporate this provision for certification without modification in all lower tier subcontracts. The contractor may rely on the certification of a prospective subcontractor that it is not a firm from a foreign country included on the list of countries that discriminate against U.S. firms as published by U.S.T.R., unless the Offeror has knowledge that the certification is erroneous.

This certification is a material representation of fact upon which reliance was placed when making an award. If it is later determined that the Contractor or subcontractor knowingly rendered an erroneous certification, the Federal Aviation Administration may direct through the Owner cancellation of the contract or subcontract for default at no cost to the Owner or the FAA.

A26 VETERAN'S PREFERENCE

A26.1 CONTRACT CLAUSE

VETERAN'S PREFERENCE

In the employment of labor (excluding executive, administrative, and supervisory positions), the contractor and all sub-tier contractors must give preference to covered veterans as defined within Title 49 United States Code Section 47112. Covered veterans include Vietnam-era veterans, Persian Gulf veterans, Afghanistan-Iraq war veterans, disabled veterans, and small business concerns (as defined by 15 U.S.C. 632) owned and controlled by disabled veterans. This preference only applies when there are covered veterans readily available and qualified to perform the work to which the employment relates.

Special Provisions



Rantoul National Aviation Center

Phase 3: Construct Wildlife Deterrent Fence

IL Project No. TIP-4687
SBG Project No. 3-17-SBGP-139/144
Contract No. RA017
Item 05A

Burns & McDonnell Project No. 108681

100% Submittal
March 01, 2019

INDEX AND CERTIFICATION

Phase 3: Construct Wildlife Deterrent Fence

IL Project No. TIP-4687
SBG Project No. 3-17-SBGP-139/144
Contract No. RA017
Item 05A

Project 108681

Special Provisions Index

<u>Section Number</u>	<u>Description</u>	<u>Number of Pages</u>
40	Scope of Work	2
50	Control of Work	4
60	Control of Materials	2
70	Legal Regulations and Responsibility to Public	2
80	Prosecution and Progress	2
150520	Mobilization	1
150530	Traffic Maintenance	1
151	Clearing and Grubbing	1
156000	Erosion Control	1
162	Chain-Link Fences (Class E)	6
610	Structural Portland Cement Concrete	1
901	Seeding	4
905	Topsoiling	2
908	Mulching	1

Certification

I hereby certify, as a Professional Engineer in the state of Illinois, that the information in this document was assembled under our direct personal charge. This Special Provisions are not intended or represented to be suitable for reuse by the Village of Rantoul or others without specific verification or adaptation by the Engineers. This certification is made in accordance with the provisions of the laws and rules of the Illinois Department of Financial and Professional Regulation under 225 ILCS 325 Administrative Code.

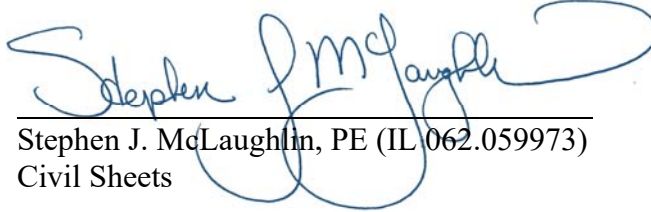
Stephen J. McLaughlin, PE (IL 062.059973)
Civil Sheets

Date: February 28, 2019
(Reproductions are not valid unless signed,
dated, and embossed with Engineer's seal)



GENERAL

These Special Provisions, together with the applicable *Standard Specifications for Construction of Airports, Policy Memorandums*, Contract Requirements for Airport Improvement Projects, Rules and Regulations, Payroll Requirements and Minimum Wage Rates which are hereto attached or which by reference are herein incorporated, cover the requirements of the State of Illinois, Department of Transportation, Division of Aeronautics and the representatives of the Village of Rantoul (Sponsor) for the Phase 3 of Construct Wildlife Deterrent Fence project at the Rantoul National Aviation Center, Rantoul, Illinois.

GOVERNING SPECIFICATION AND RULES AND REGULATIONS

The *Standard Specifications for Construction of Airports*, State of Illinois Department of Transportation, Division of Aeronautics, adopted April 1, 2012 shall govern the project except as otherwise noted in these Special Provisions. In the case of conflict with any part or parts of said specifications, the said Special Provisions shall take precedence and shall govern. Where noted within the Special Provisions, the Illinois Department of Transportation Standard Specifications for Road and Bridge Construction dated April 1, 2016 shall apply. Where conflicts arise regarding contract documents versus IDOT Airport and Highway Standards and Standard Drawings, the contract documents shall govern.

TABLE OF CONTENTS

SECTION/ ITEM	DESCRIPTION
	<u>Division I - General Provisions</u>
40	Scope of Work
50	Control of Work
60	Control of Materials
70	Legal Regulations and Responsibility to Public
80	Prosecution and Progress
	<u>Division II – Paving Construction Details</u>
150520	Mobilization
150530	Traffic Maintenance
151	Clearing and Grubbing
156000	Erosion Control
610	Structural Portland Cement Concrete
	<u>Division III – Fencing (Wire Fences)</u>
162	Chain-Link Fences (Class E)
	<u>Division V - Turfing</u>
901	Seeding
905	Topsoiling
908	Mulching

APPENDICES

A IDA MEMORANDUMS

- 96-1 Item 610, Structural Portland Cement Concrete: Job Mix Formula Approval & Production Testing
- 2001-1, Requirements for Cold Weather Concreting
- 18-08.3, Acceptance Procedure for Finely Divided Minerals Used in Portland Cement Concrete and Other Applications

Division I – General Provisions

SECTION 40. SCOPE OF WORK

40-05 MAINTENANCE OF TRAFFIC

ADD: The contractor shall provide and install any warning signs on roads, streets, highways and/or airport access points (trucks entering highway, etc.) that are required by the Champaign County Division of Transportation and/or the Village of Rantoul Public Works Department.

ADD: To maintain airport operations and to facilitate the construction of the proposed work, the project has been divided into separate phases in accordance with Advisory Circular 150/5370-2G Operational Safety on Airports During Construction. References to Construction Safety and Phasing Plans (CSPP) in that document shall be interpreted to mean the phase limits, barricade locations, access points and notes shown on the Contractor Access, Staging and Safety Plan sheets included in the as-bid contract documents. When “safety” is used or referred to in the contract documents and in the advisory circular(s) it shall be redefined by this contract as meaning “operational safety”. The Construction Operational Safety and Phasing Plan (CSPP) establishes the airport and project specific requirements, supplementing the requirements in the AC, that are to be included in the contractor’s bid for maintaining operational safety during construction.

The Construction Operational Safety and Phasing Plan (CSPP) contained herein has been approved by both the Airport and the FAA. The contractor shall be required to divide the overall work into separate phases in substantial conformance with the CSPP shown in the plans, except as allowed by the contract documents and approved by the Division on behalf of the FAA. Durations specified for individual phases shall become requirements of the contract and shall be subject to liquidated damages.

10 days prior to the preconstruction conference the contractor shall submit a Safety Plan Compliance Document (SPCD) to the airport describing how he will comply with the requirements of the advisory circular plus the CSPP and supplying any details that could not be determined before contract award. The SPCD must include a certification statement by the contractor that indicates he understands the operational safety requirements of the CSPP, that the contractor has incorporated these requirements into their overall work plan and that the contractor will maintain the right of control for all means, methods and details of the work performed by the contractor and any of his subcontractors within the framework of the operational safety plan.

The Contractor shall be fully aware and continuously monitor all requirements and activities for compliance with the contract documents and Advisory Circular 150/5370-2G.

Ten days prior to the commencement of each phase the contractor shall submit an updated Safety Plan Compliance Document for that phase that meets the requirement of Advisory Circular 150/5370-2G. The updated Safety Plan Compliance Document(s) shall detail implementation of the construction haul routes, procedures utilized by the contractor to eliminate conflicts between construction operations and aircraft traffic shall be included.

Significant Changes to the Construction Operational Safety and Phasing Plan (CSPP) may require aeronautical review by the Division through the FAA’s OEAAA System. Modification of the Construction Operational Safety and Phasing Plan (CSPP) and/ or the critical points shown in the

contract documents will require airspace approval from Division/ FAA and may require the contractor to submit FAA Form 7460 for Approval.

ADD: The contractor activity on the airfield shall be limited to the limits of construction as identified on the Contractor Access, Staging and Safety Plan drawings. Beyond the limits of construction, the contractor shall not have access to any part of the active airfield pavement with any equipment or personnel without the approval of Airport Management.

Maintenance of Airport Systems are critical to the operation of the Airport and the safety and/or security of the traveling public. Prior to beginning work the contractor shall investigate existing systems which may be located within the work area and locate all existing utilities. The contractor may seek assistance from the Joint Utility Locating Information for Excavators (JULIE), Engineer, Resident Engineer, Airport and FAA with locating utilities but the final responsibility for all utility locates lies solely with the contractor. If the Contractor's investigation reveals that a utility must be relocated to allow for the performance of the work in the plans, the contractor shall immediately notify the Resident Engineer and remain clear of the utility until resolution has been determined by the Division and the Airport. Any system, including but not limited to systems associated with security, air navigation, weather, airfield lighting damaged by the Contractor's operations shall be immediately repaired to the satisfaction of the owner. No delay shall be taken in the repair of the damaged facility. The Contractor shall not be allowed to finish work for the day until the utility has been repaired.

The contractor shall provide his own radio capable of transmitting and receiving on the Unicom frequencies of 123.0 MHz.

The Contractor shall provide and maintain construction entrance signage on all public use roads intended to be used by his operations as required by the Illinois Department of Transportation, Village of Rantoul and Champaign County Division of Transportation. The Contractor shall be responsible for coordinating all hauling and access on State, City, Township or County roads with the agency responsible for the roadway.

SECTION 50. CONTROL OF WORK

50-04 COOPERATION OF CONTRACTOR

ADD: The completion of this project in the specified number of contract calendar days is of extreme importance to the Airport. The contractor shall provide updated progress schedules at each scheduled progress meeting.

50-05 COOPERATION BETWEEN CONTRACTORS

REVISE: The first sentence of the second paragraph to read:

The contractor shall plan and conduct his/her work so as not to interfere or hinder the progress of work being performed by other contractors or Airport personnel.

ADD: The Contractor shall acquaint himself with all other contracts prior to bidding and shall cooperate with Airport management and any other contractors who may be working on other contracts.

50-06 CONSTRUCTION LAYOUT STAKES

DELETE: The first paragraph.

ADD: As the first paragraph.

The Contractor will be required to furnish and place construction layout stakes for this project.

The Resident Engineer will locate and reference two (2) control points and will establish benchmarks along the line of the improvement outside construction limits. The Contractor shall locate and reference the centerline of survey, which shall also consist of locating and referencing control points such as the point of curvature, points of tangent, and sufficient points on tangent to provide a line of sight. Control points set by the Resident Engineer shall be identified in the field to the Contractor, and the field notes shall be kept in the office of the Resident Engineer.

ADD: The Resident Engineer shall establish the project control points one time. If at any time during construction the control points need to be re-established this shall be done at the Contractor's expense.

RESPONSIBILITY OF THE RESIDENT ENGINEER

DELETE: Lines A & B.

ADD:

A. The Resident Engineer will locate and reference two (2) control points within the limits of the project.

B. Benchmarks will be established along the project outside of construction lines.

DELETE: Line D.

REVISE: Line E to read:

The Resident Engineer may make random checks

DELETE: Line F.

DELETE: Line L.

ADD: As paragraph M:

M. It is not the responsibility of the Resident Engineer to check the correctness of the Contractor's stakes or forms, except as provided herein; however, any errors that are apparent shall be immediately called to the Contractor's attention, and he shall be required to make the necessary correction before the stakes are used for construction purposes.

50-08 AUTHORITY OF THE RESIDENT ENGINEER

ADD: The Resident Engineer shall not be allowed to modify the contract documents without the approval of the Division.

50-12 LOAD RESTRICTIONS

ADD: Access to the construction work area is limited to the haul routes as shown on the Contractor Access, Staging and Safety Plan drawings. The use of existing airfield pavements by contractor construction traffic including all haul trucks is prohibited unless previously approved by the Airport Manager. Any damage to existing Airport pavement due to construction traffic operating beyond the approved work limits, hauling outside of the approved haul/access routes and construction traffic operating in prohibited areas shall be repaired by the Contractor at his own expense to the satisfaction of the owner.

The contractor shall coordinate construction hauling, construction access and load restrictions with the Champaign County Director of Transportation and/or the Township Road Commissioner and the Village of Rantoul. The Contractor shall be responsible for damage to any airfield pavement or public road caused by his construction operations. Any damage to existing airfield pavements or public roads shall be replaced by the Contractor at his own expense to the satisfaction of the Owner.

50-13 MAINTENANCE DURING CONSTRUCTION

ADD: The contractor shall make provisions in the work to maintain positive drainage from the work areas and to minimize the ponding of water

ADD: Periodically, the Contractor shall have on site and available for use a self-propelled, vacuum or regenerative (recirculating) air pavement sweeper, a pavement blower or tractor mounted "sweeper box" to clean pavement where fence is to be cored and installed.

ADD: Material tracked onto public streets shall be removed continuously during the work.

50-16 FINAL INSPECTION

DELETE: The first sentence of the first paragraph.

ADD: As the first sentence of the first paragraph.

Upon due notice to the Resident Engineer from the Contractor of presumptive completion of the entire project, the charging of Contract Time shall be suspended and the Engineer will make an inspection.

ADD: After the first sentence of the second paragraph:

The charging of Contract Time shall resume upon receipt of the punch list from the Engineer and shall continue until the remaining work, including the applicable requirements of Section 40-08, Final Clean-up, is completed to the Sponsor's satisfaction.

50-18 PLANS AND WORK DRAWINGS

ADD: After the third paragraph:

Submittals shall include items such as: Contractor's, manufacturer's, or fabricator's drawings; descriptive literature including (but not limited to) catalog cuts, diagrams, operating charts or curves; test reports; samples; O&M manuals (including parts list); certifications; warranties; and other such required submittals.

Prior to submission, the Contractor shall review all shop drawing submittals for accuracy, completeness, and compliance with the contract requirements. The Contractor shall stamp, sign and date each submittal indicating Contractor approval of the submittal.

When submittals require close coordination of a number of products, the Contractor shall coordinate a concurrent submittal of all such products. The Project Engineer may withhold action on a submittal requiring coordination with other submittals until all related submittals are received.

Each submittal shall be complete and in sufficient detail to allow ready determination of compliance with contract requirements. Any deviation from contract requirements shall be clearly identified on the shop drawing submittal and supporting documentation for such deviation shall be attached. The Project Engineer reserves the right to rescind inadvertent acceptance of submittals containing unidentified deviations.

REVISE: The second sentence of the seventh paragraph to read as follows:

Such review will not relieve the Contractor of the responsibility for complying with the contract document requirements or for any error that may exist in the submittal. The Contractor is responsible for the dimensions and designs of adequate connections, detail and satisfactory construction of all work.

ADD: The following information shall be clearly marked on each shop, working, and layout drawing, catalog cut, pamphlet specifications sheet, etc., submitted.

PROJECT LOCATION: Rantoul National Aviation Center

PROJECT TITLE: Phase 3: Construct Wildlife Deterrent Fence

PROJECT NUMBERS: Illinois Project: TIP-4687
AIP Project: 3-17-SBGP-139/144

CONTRACT ITEM: (Pay Item Number & Description)

SUBMITTED BY: (Contractor/Subcontractor Name)

DATE: (Date of Submittal)

ADD: The Project Engineer shall return incomplete or vague material shop drawing submittals for completion prior to review.

Shop drawing submittals shall contain a letter of certification from the producer stating that all materials furnished for the project conform to the requirements of the plans and specifications including conformance with the Buy American Act. Letters of certification from the producer shall be dated no more than six (6) months prior to the date it is submitted to the Project Engineer. Letters of certification from producers to verify submitted material conforms to the requirements of the contract shall be submitted on company letterhead and include the project name, location and project numbers. Submittals not including this information shall not be reviewed and returned as incomplete. Incomplete shop drawing submittals causing re-submittal(s) shall not be allowed as justification for additional contract time.

The Project Engineer will review each submittal; mark corrections or modifications required and return it to the Contractor. The Project Engineer will stamp each submittal with an action stamp and will mark the stamp appropriately to indicate action taken as follows. Submittals marked "Revise and Resubmit" or "Rejected" shall not be used at the project site. All submittals must ultimately receive "No Exceptions Taken" stamp from the Project Engineer to be eligible for payment. Submittals stamped "Exceptions Taken as Noted" are not considered approved shop drawings.

1. "No Exceptions Taken": Means fabrication/installation may be undertaken. Submittals stamped as such do not authorize changes to the contract price or time.
2. "Exceptions Taken as Noted": Same as "No Exceptions Taken" provided the Contractor complies with the corrections noted on the submittal by the Project Engineer. The Contractor is still obligated to resubmit the submittal including the corrections made by the Project Engineer so ultimately a shop drawing stamped "No Exceptions Taken" may be forwarded to the Division. Submittals not stamped Approved are not considered approved shop drawings.
3. "Revise and Resubmit": Fabrication and/or installation MAY NOT be undertaken. Make appropriate revisions and resubmit limiting corrections to items marked.

SECTION 60. CONTROL OF MATERIALS

60-01 SOURCE OF SUPPLY AND QUALITY REQUIREMENTS

REVISE: The first sentence of the third paragraph as follows:

. . . shall provide, prior to delivery, . . .

60-03 CERTIFICATION OF COMPLIANCE

ADD: All materials utilized in the construction of the referenced project shall be certified in conformance with the MANUAL FOR DOCUMENTATION OF AIRPORT MATERIALS by the Illinois Department of Transportation, Division of Aeronautics, dated April 1, 2010, or latest edition. This manual is available by contacting Mr. Mike Wilhelm, Division of Aeronautics at (217) 785-4282. The cost of providing the required material documentation and certifications shall not be paid for separately, but shall be considered incidental to the associated item.

60-06 STORAGE OF MATERIALS

ADD: Material shall be stockpiled at the locations designated by the Resident Engineer and as shown on the plans. The contractor may request stockpile locations other than as shown in the plans. The alternate locations are subject to the approval of the FAA and airport manager and may require additional demarcation consisting of lighting and flagging.

Flagging, if required, shall consist of prominently marking the stockpiles with red flags and lighted by red light units.

Stockpiles shall not violate FAA Part 77 airport surfaces.

Stockpiled material should be constrained in a manner to prevent movement resulting from aircraft blast or wind conditions in excess of 10 knots.

60-11 CERTIFICATION OF MATERIALS

ADD: The contractor shall certify all materials contained in the contract. Certification documentation shall be submitted to the Resident Engineer. It shall be the sole responsibility of the contractor to ensure the delivery of adequate and accurate documentation prior to the delivery materials. Materials incorporated into this project without the prior approval of the Resident Engineer will not be recommended for payment by the Resident Engineer.

As a guide to the certification process and requirements, the Contractor shall use the Illinois Department of Transportation/Division of Aeronautics MANUAL FOR DOCUMENTATION OF AIRPORT MATERIALS (latest edition). Copies of this manual are available from the Illinois Division of Aeronautics. The MANUAL FOR DOCUMENTATION OF AIRPORT MATERIALS defines the Resident Engineer's/Contractor's responsibilities (Sections 200/300). The Contractor shall have the sole responsibility to provide the Engineer with appropriate documentation to satisfy the contract certification requirements prior to the delivery of materials.

ADD: All submittals shall contain the following information:

PROJECT LOCATION: Rantoul National Aviation Center
PROJECT TITLE: Phase 3: Construct Wildlife Deterrent Fence

PROJECT NUMBERS: IL Project No. TIP-4687
SBG Project: 3-17-SBGP-139/144

CONTRACT ITEM: (i.e., AR401610 – Bituminous Surface Course)
SUBMITTED BY: (Contractor/Subcontractor Name)
DATE: (Date of Submittal)

If the Division of Aeronautics requires additional documentation, they shall request it through the Resident Engineer.

SECTION 70. LEGAL REGULATIONS AND RESPONSIBILITY TO PUBLIC

70-17 CONTRACTOR'S RESPONSIBILITY FOR UTILITY SERVICE AND FACILITIES OF OTHERS

REVISE: The second paragraph as follows:

“ . . . , the approximate locations and owners have been indicated on the plans.”

DELETE: “Person to Contact” table after the second paragraph.

ADD: After the fifth paragraph:

The Contractor shall be responsible for locating Airport owned utilities.

Should any utilities or cables require location, the following people shall be contacted:

Rantoul Airport Utility Contacts

Utility Service or Facility	Person to Contact	Contact Phone
AWOS & Airfield Lighting Cables	Eric Vences	217-892-6896 or 217-974-5747 (cell)
Village of Rantoul (Water & Sewer Services)	Greg Hazel	217-892-2178
Electric Cables	JULIE	800-892-0123
Telephone Cables	JULIE	800-892-0123
Gas Lines	JULIE	800-892-0123

70-26 CONTRACTOR'S RESPONSIBILITY FOR SAFETY DURING CONSTRUCTION

DELETE this section and ADD:

As a minimum, the Contractor shall be responsible for safety during construction as follows:

- (1) Review the requirements in AC 150/5370-2 (current edition) and comply with items listed as contractor's responsibility.
- (2) Implement a CSPP and SPCD as required in AC 150/5370-2 (current edition) and ensure that construction personnel are familiar with operational safety procedures and regulations on the Airport.
- (3) Provide a 24 hour point of contact that will coordinate an immediate response to correct any construction-related activity that may adversely affect the operational safety of the Airport.
- (4) Provide a safety officer/construction inspector(s) trained in airport safety to maintain the CSPP and SPCD and to monitor all construction activities.

- (5) Restrict movement of construction vehicles to construction areas as flagging and barricading, erecting temporary fencing, or providing escorts, as appropriate.
- (6) Ensure that no construction employees, employees of subcontractors or suppliers, or other persons enter any part of the aircraft operations area from construction site unless authorized.

SECTION 80. PROSECUTION AND PROGRESS

80-02 PROGRESS SCHEDULE

ADD: In the event that work does not proceed as shown on the current progress schedule, the Contractor shall provide an updated progress schedule on a weekly basis until such time that the work is proceeding according to the current progress schedule.

80-05 LIMITATION OF OPERATIONS

ADD: All construction activity shall conform to the approved safety and phasing plan, general notes and FAA Advisory Circular 150/5370-2G, or latest version. The Contractor shall keep all personnel, equipment, materials and construction activity outside of the Object Free Areas of all active runways and taxiways, as dimensioned in the drawings.

ADD: It is intended to plan, conduct, and complete the work in these critical traffic areas in such a manner that the length and amount of interruption to aircraft traffic at the Airport is minimized.

The Contractor shall comply with Federal Aviation Regulations Part 107 (Airport Security) and with all rules and regulations of the Airport, including, but not limited to, control and access to the airfield by Contractor's, employees and agents.

80-08 DETERMINATION OF THE CONTRACT TIME

ADD: After the fourth paragraph:

The Engineer will make charges against Contract Time after the presumptive completion of the entire project as provided for in Section 50-16, Final Inspection.

ADD: After the last paragraph of this section:

For this project, the following number of calendar days available for work per month has been assumed to be:

<u>Month</u>	<u>WorkableCalendarDays</u>
January	0
February	0
March	0
April	0
May	15
June	17
July	17
August	17
September	16
October	16
November	14
December	0

For an extension of contract time due to inclement weather to be considered, the actual total number of calendar days available for work on controlling items must be less than the total number of workable calendar days assumed for the duration of the contract.

Requests for extension of contract time on calendar day projects caused by inclement weather, shall, as a minimum, be supported with National Weather Bureau data and project diaries. Requests for extension of contract time due to inclement weather will not be considered until after final acceptance.

As part of the request for contract time extension review, consideration may be given to how timely the Contractor prosecuted the work up to the point of the delays and the efforts by the Contractor to get back on schedule including the addition of labor or equipment and the extension of work hours and work days.

No allowance will be made for anticipated profits.

80-13 EMPLOYEE'S PARKING AREA

ADD: The Contractor's employees shall park personal vehicles at the laydown area location identified on the plans or as agreed to at the pre-construction meeting. Personal vehicles are not permitted on the construction site and use of personal vehicles beyond the staging area will not be allowed.

80-13 CONTRACTOR'S ACCESS TO AIRFIELD

ADD: The Contractor activity on the airfield and haul routes shall be limited to the limits of construction identified on the Contractor Access, Staging and Safety Plan and notes drawings. Beyond the limits of construction, the contractor shall not have access to any part of the active airfield pavements (runways, aprons, or taxiways) with any equipment or by any personnel without the approval of the Airport.

Upon completion of construction, all areas disturbed by the contractors operations including the haul road and staging and storage site shall be re-graded, cleaned of all debris and restored to original un-disturbed conditions to the satisfaction of the Resident Engineer and the Owner. Clean up and restoration shall not be paid for separately but shall be considered incidental to the contract.

ITEM 150520 MOBILIZATION

DESCRIPTION

150-1.1

ADD: This item includes restoration of any pavement or turf areas outside the proposed improvements that are damaged by contractor operations.

BASIS OF PAYMENT

150-3.1

ADD: Payment will be made under:

Item AR150520 – Mobilization – per lump sum.

ITEM 150530 TRAFFIC MAINTENANCE

DESCRIPTION

150530-1.1 This item shall consist of furnishing, placing, maintaining and removing traffic control devices including road closure markings, barricades, flags and other items as indicated in the plans or standard specifications.

EQUIPMENT AND MATERIALS

150530-2.1 Road closure markings, barricades, flags and other traffic control devices as indicated in the plans or standard specifications.

METHOD OF MEASUREMENT

150530-3.1 The furnishing, placing, maintaining and removing traffic control devices shall be measured as a lump sum item completed and accepted by the Engineer.

The Construction Phasing Plan represents one suggested alternative for the construction sequencing and method of handling traffic. Revisions or modifications of the traffic control shall have the Engineer's written approval. Any deviation from the proposed plan shall be approved in writing by the Engineer before implementation.

At the pre-construction conference, the Contractor shall furnish the name and telephone number of the individual in the Contractor's employ who is to be responsible, 24 hours a day, for the installation and maintenance of traffic control for the Project. When the actual installation and maintenance are to be accomplished by a subcontractor, consent shall be requested of the Engineer at the time of the preconstruction conference. This shall not relieve the Contractor of furnishing a responsible individual in the Contractor's direct employ. The Engineer will provide the Contractor with the name of its representative who will be responsible for administration of the traffic control.

Removal, relocation, maintenance and inspection of traffic control devices, as required by the Contractor's activities, shall be included in the item and not measured separately for payment.

BASIS OF PAYMENT

150530-5.1 Payment for this item shall be incidental to the contract for the completed work. This price shall be full compensation for furnishing all material, for all preparation, assembly and installation of materials, for all maintenance of materials, for all removals, and for all labor, equipment, tools and incidentals necessary to complete the item.

ITEM 151 CLEARING AND GRUBBING

DESCRIPTION

151-2.1

Revise the fourth paragraph as follows:

“Clearing and grubbing shall consist of clearing the surface of the ground of the designated areas of all trees, stumps, down timber, logs, snags, brush, undergrowth, hedges, heavy growth of grass or weeds, fences structures, debris, and rubbish of any nature, natural obstructions or such material which in the opinion of the Resident Engineer is unsuitable for the installation of fencing or any part of the work, including landscaping, and the foundation of strips, pavements, or other required structures, including the grubbing of stumps, roots, matted roots, foundations, and the disposal from the project of all spoil materials resulting from clearing and grubbing.”

Add the following:

“Burning shall not be permitted under this Contract.

BASIS OF PAYMENT

151-4.1

Delete this Section.

151-4.2

Delete this Section.

151-4.3

ADD: Payment will be made under:

Item AR151450 – Clearing and Grubbing – per acre.

ITEM 156000 EROSION CONTROL

MATERIALS

156-2.1

DELETE: First paragraph of this section and replace with:

This fence shall be of either a pre-fabricated type or shall be constructed in the field, and regardless of the fabrication method, shall be of materials meeting the dimensions and material requirements shown in the Plans. The fabric for silt fence shall be a woven fabric meeting the requirements of AASHTO M 288 for unsupported silt fence with less than 50 percent geotextile elongation.

BASIS OF PAYMENT

156-5.1

ADD:

Payment will be made at the contract unit price per lump sum for all construction entrances installed. This price shall be full compensation for furnishing all materials and for all preparation, installation, maintenance, removal and restoration of construction entrance areas with turf seeding.

ADD: Payment will be made under:

Item AR156510 – Silt Fence – per linear foot.

Item AR156520 – Inlet Protection – per each.

ITEM 610 STRUCTURAL PORTLAND CEMENT CONCRETE

DESCRIPTION

610-1.1

ADD: This item shall include concrete used in the installation of fence posts and other miscellaneous items that require structural PCC.

The cost of furnishing and installation of structural concrete shall be considered incidental to the contract unit price for the associated pay item. The prices shall be full compensation for furnishing all materials and / or preparation, delivering and installation of these materials, and for all labor, equipment, tools and incidentals necessary to complete the item.

The contractor must provide the necessary submittals for the structural concrete including constituent materials of the mix prior to incorporating the structural concrete into the work. No payment will be made for the associated pay items until satisfactory submittal documentation has been provided.

This item shall also include the requirements prescribed in Illinois Division of Aeronautics Policy Memorandums 18-08.3, Acceptance Procedure for Finely Divided Minerals Used in Portland Cement Concrete and Other Applications; 96-1, Item 610, Structural Portland Cement Concrete: Job Mix Formula Approval and Production Testing, and; 2001-1, Requirements for Cold Weather Concreting, current issues.

CONSTRUCTION METHODS

610-3.16

ADD: All Structural Portland Cement Concrete placed under Item 610 which is exposed to weather, shall be cured and protected by the Liquid Membrane Curing Method using an IDOT-approved curing compound, as specified herein, and whose cost shall be incidental to Item 610. The compound shall meet all Contract requirements for materials, including the Buy American Preferences Act (49 U.S.C. § 50101)."

ITEM 162 CHAIN-LINK FENCES (Class E)

DESCRIPTION

162-1.1

Replace the first Paragraph with the following:

All metal materials used in the fencing and fencing materials shall be fabricated from steel made in the U. S. Contractor shall provide certification that the steel was 100 percent domestic-made steel, and that the fence materials were fabricated in the United States.

This item shall also include the removal of existing fence and the removal of manual and electric gates at the locations shown on the Plans or as directed by the Resident Engineer.

MATERIALS

162-2.1 FABRIC. Add the following:

For Base Bid items, all fabric shall be galvanized/coated. For Additive Alternate #1 items, fabric shall be vinyl-coated (black) over galvanized/coated in the terminal area at the locations shown in the construction plans.

162-2.2 BARBED WIRE. Add the following:

All new Class E fence shall include barbed wire, as specified in Item 162 and in these Special Provisions.

162-2.3 FENCE POSTS, POST TOPS AND EXTENSIONS, RAILS, GATES BRACES, STRETCHER BARS, AND CLIPS. Add the following:

Top rail shall be furnished for all Class E fence under this item. Additional corner posts shall be furnished at the locations shown in the Plans.

Fence materials shall meet the specified requirements for 10-foot chain-link fence (posts for the 8-foot high lengths shall be of the same dimensions as that for the 10-foot fence) based upon the details shown in the Construction Plans for the various heights specified.

Type C pipe may be used. The manufacturer shall furnish test results that indicate that the Type C pipe furnishes the same corrosive resistance as Type A and B pipe, tested in accordance with the materials standard for this item.

IDOT Type B metal posts are approved in the IDOT Standard Specifications for Road and Bridge Construction, Section 1006.29.

For Additive Alternate #1 items, fence materials shall be vinyl-coated (black) over galvanized/coated.

162-2.5 WIRE TIES AND TENSION WIRE. Add the following:

For Additive Alternate #1 items, wire ties and tension wire shall be vinyl-coated (black) over galvanized/coated.

162-2.11 GATE CHAIN AND PADLOCKS. The Contractor shall furnish a new security chain and padlock for each swing or slide gate. Chain shall be 5/16-inch stainless steel cut into a three foot length. Padlock shall be solid brass body, corrosion resistant and ideal for harsh environments. Padlock dimensions shall be 2-inch shackle, 2-inch wide and 3/4-inch thick. Padlocks shall be keyed to match existing Airport padlock system. The Contractor shall coordinate the furnishing of these padlocks with the Airport Owner.”

162-2.12 ELECTRICAL GROUNDS. The fence shall be bonded and grounded as detailed on the Plans. The ground wire connections to the fencing shall be with UL listed grounding connectors of cast bronze body and bronze or stainless steel bolts, nuts, and washers. Grounding connectors shall be sized and suitable for the respective application. Connections to ground rods shall be with UL listed grounding connectors suitable for direct burial in earth or exothermic weld type connectors, Cadweld by Erico Products, Inc., Solon, Ohio, (Phone 1-800-248-9353), Thermoweld by Continental Industries, Inc., Tulsa, Oklahoma (Phone 918-663-1440), or Ultraweld by Harger, Grayslake, Illinois (Phone 1-800-842-7437) or approved equal. Exothermic weld connections shall be installed in conformance with the respective manufacturer's directions using molds suitable for each respective application. Ground rods shall be 5/8-inch diameter by 8 feet long (minimum), UL-listed, copper-clad. Steel used to manufacture ground rods shall be 100 percent domestic steel. Include certification that ground rods are made with 100 percent domestic steel. The ground wire used to bond the fencing to the ground rod shall be #6 AWG bare solid copper conductor. The items furnished and installed in providing the specified grounding shall not be measured separately for payment, but shall be included in the Contract unit price for fencing.

162-2.13 CERTIFICATION AND SHOP DRAWINGS. The Contractor shall submit shop drawings detailing all fence items to be furnished for approval by the Project Engineer. The Contractor shall provide a written certification that all fence materials used in the Work meet the Contract Documents.

CONSTRUCTION METHODS

162-3.1 CLEARING FENCE LINE. Add the following:

The Contractor shall correct any irregularities in the ground's surface prior to installation of the fence where the irregular surface is located in on the Plans. Also, the Contractor shall re-grade the existing ground where indicated on the Construction Plans to furnish a fence grade satisfactory to the Resident Engineer. This grading shall be furnished in accordance with Item 152; however, separate payment will not be made, as this work shall be incidental to Fence installation, Item 162. This grading shall not be limited to, but shall be in addition to, the grading shown on the Plans or elsewhere specified.

INSTALLING POSTS. Delete the first sentence of the last Paragraph and replace with the following:

All posts shall be set to the minimum depths below the existing ground line as detailed in the Plans. All fence post lengths shall consider the footing depths shown in the details. Concrete encasement shall extend an additional 6-inches below the post end.

Add the following:

In paved areas, the post hole digging shall be completed so as to minimize any damage to pavements. Prior to the pouring of concrete, the pavement shall be neatly cored to the required diameter of the footing to the full depth of the asphalt or concrete. Saw-cutting and pavement protection shall not be measured for payment but shall be included in the Contract unit price for new fence. Any damaged pavements shall be replaced by the Contractor to the satisfaction of the Resident Engineer and at no additional costs to the Contract. In existing paved areas and at swing or sliding gate openings, the additional 2-foot buried portion of the fence shall not be installed.

162-3.4 INSTALLING BRACES. Add the following:

At terminal (end, corner and pull) and gate posts, the fabric shall be fastened to the post with stretcher bars and bands that extend below the existing ground to secure the 24 inches of buried fence fabric.

162-3.5 INSTALLING FABRIC. Add the following:

Where shown in the Plans, the Contractor shall construct a trench of adequate width and depth (greater than 24 inches) to permit the installation of the fence fabric to extend 24 inches below the ground line. The fabric shall be smooth and even throughout the 24-inch depth. The trench shall be backfilled with excavated material and compacted to the satisfaction of the Resident Engineer. In existing paved areas and at swing or sliding gate openings, the additional 2-foot buried portion of the fence shall not be installed.

The bottom tension wire shall be located 2 inches above the final ground line.

162-3.9 EXISTING FENCE CONNECTIONS. Add the following:

The furnishing and installing of new, additional or replacement terminal posts, line posts, end posts, fabric and brace spans and any other incidental modifications needed to provide an acceptable connection of the new fence to any existing fence, regardless of type of existing fence, as shown in the Plans or as directed by the Resident Engineer, shall not be paid separately, but shall be included in the Contract unit price for new fence.

162-3.11 FENCE AND GATE REMOVAL. Add the following:

The fence and gate to be removed shall be chain-link or similar type of fence. The existing fence shall be removed completely, including posts and foundations.

In turf areas, the existing posts shall be pulled and not cut off. All resulting holes in turf shall be filled and compacted to the satisfaction of the Resident Engineer. Turf areas disturbed by removal shall be restored in accordance with Item 901, except the areas will not be measured for payment.

In paved areas, the existing posts shall be cut off and ground to a depth of two (2.0) inches below the existing pavement surface. All resulting post holes in existing pavements shall be filled with an IDOT-approved nonshrink grout.

All removed materials not accepted by the Airport Owner, shall be disposed of off airport property.

The Contractor will remove the gates, gate operators, card readers, control stations, concrete footings/foundations, bollards, conduits, wiring, handholes, safety switches and other miscellaneous fittings associated with the gate to be removed. The existing power and control cables from the power source to the existing gate operators will be removed from the conduits. All removed materials not accepted by the Airport Owner, shall be disposed of off airport property.

- A. Contractor shall examine the site to determine the extent of the work.
- B. Contractor shall comply with the requirements of FAA AC No. 150/5370-2G (or most current issue) "OPERATIONAL SAFETY ON AIRPORTS DURING CONSTRUCTION".
- C. Coordinate removal of existing gates with the Airport Manager and/or respective Maintenance Staff and to maintain security of the Airport facilities.
- D. The existing gate operators and card readers shall be removed and turned over to the Airport Owner. Prior to the electric gate removals, the Contractor shall confirm all associated equipment to be turned over to the Airport with the Airport Director and/or the Resident Engineer. Providing the equipment is to be turned over to the Airport, care is to be taken by the Contractor not to damage the equipment while removing it. The Contractor will deliver the equipment to the storage area on the Airport selected by the Airport Owner. Provided that the Airport does not accept the equipment, the Contractor will dispose of it off-site.
- E. The cable shall be disconnected from the distribution panel at the respective power source. Cable shall be removed where accessible and when under grade abandoned. Contractor may remove cable that is scheduled to be abandoned and shall have the salvage rights to that cable. Removal of existing cables shall be at no additional cost to the Contract.
- F. Turf Areas: All resulting holes in turf shall be filled and compacted to the satisfaction of the Resident Engineer. Turf areas disturbed by removal shall be restored in accordance with Item 901, except the areas will not be measured for payment
- G. Paved Areas: In paved areas, the existing posts shall be cut off and ground to a depth of two (2.0) inches below the existing pavement surface. All resulting post holes in existing pavements shall be filled with an IDOT-approved nonshrink grout."

162-3.13 LOCATE EXISTING UTILITIES.

The location, size, and type of material of existing underground and/or aboveground utilities that may be indicated on the Plans are not represented as being accurate, sufficient or complete. Neither the Owner nor the Engineer assumes any responsibility whatever in respect to the accuracy, completeness, or sufficiency of the information. There is no guarantee, either expressed or implied, that the locations, size and type of material of existing underground utilities indicated are representative of those to be encountered in the construction. It shall be the Contractor's responsibility to determine the actual location of all such facilities, including service connections to underground utilities. Prior to construction, the Contractor shall notify the utility companies of his operational plans and shall obtain from the respective utility companies detailed information and assistance relative to the location of their facilities and the working

schedule of the companies for removal or adjustment where required. In the event an unexpected utility interference is encountered during construction, the Contractor shall immediately notify the utility company of jurisdiction. The Owner's Representative and/or the Resident Engineer shall also be immediately notified. Any damage to such mains and services shall be restored to service at once and paid for by the Contractor at no additional cost to the Contract. All utility cables and lines shall be located by the respective utility.

Contact JULIE (Joint Utility Location Information for Excavators) for utility information, phone: 1-800-892-0123. Contact the FAA (Federal Aviation Administration) for assistance in locating FAA cables and utilities. Location of FAA power, control, and communication cables shall be coordinated with and/or located by the FAA. Also, contact Airport Director/Manager and Airport Personnel for assistance in locating underground Airport cables and/or utilities. Also, coordinate work with all aboveground utilities.

Payment for locating and marking underground utilities and cables will not be paid for separately, but shall be considered incidental to the respective work item for which it is required.

162-3.14 RESTORATION.

All areas disturbed by the Contractor's operations shall be restored to their original condition to the satisfaction of the Engineer and the Airport. The restoration shall include any necessary backfilling, grading, compacting and additional turfing required. The Contractor shall be responsible for maintaining all disturbed areas until final acceptance.

METHOD OF MEASUREMENT

162-4.2 Delete this Section.

162-4.3 Revise this Section to read:

Remove Class E Fence to be paid shall be the actual length of chain-link feet (including post widths) removed and completed as specified, except for the space occupied by gates.

162-4.4 Delete this Section.

162-4.5 Delete this Section.

BASIS OF PAYMENT

162-5.2 Delete this Section.

162-5.3 Revise this Section to read:

Payment shall be made at the Contract unit price per linear foot for Remove Class E Fence, as measured in Section 162-4.3. This price shall be full compensation for furnishing all materials and for all removals, restoration, including grading, backfilling, seeding and mulching, and disposal, and for all labor, equipment, tools, and incidentals necessary to complete this item.

162-5.4 Delete this Section.

162-5.5 Delete this Section.

Add: Payment will be made under:

- Item AR162228 Class E Manual Slide Gate – 28' – per each.
- Item AR162508 Class E Fence 8' – per linear foot.
- Item AR162605 Class E Gate - 5' – per each.
- Item AR162900 Remove Class E Fence - per linear foot.
- Item AR162905 Remove Gate – per each.
- Item AR162808 Class E Fence 8' w/2' Buried – per linear foot.
- Item AS162400 Vinyl Fence Upgrade – per lump sum.

ITEM 901 SEEDING

MATERIALS

901-2.1

ADD: Planting times shall be between August 20 and October 20. If fall planting is not possible, the mixture may be planted between March 15 and May 15. Seeding between June 1 and August 15 will not be permitted. If planted in the spring, the Contractor shall furnish additional measures beyond that otherwise required in these Special Provisions to prevent weed growth as recommended by a registered nurseryman at no additional cost to the Contract.

A sample of selected seed species shall be made available on request to the Resident Engineer for viability testing by the tetrazolium trichloride method, not less than 21 calendar days prior to planting.

Seed mixtures shall contain the proportion of seed of individual species indicated in the planting design. Changes in seed mixtures must be approved by the Project Engineer.

All seeds shall be guaranteed by the Contractor to be true to name. All seeds shall have the proper preplanting treatments, including stratification, scarification and/or inoculation to promote good germination and growth, prior to any seeding.

All seedings shall be planted at the specified rates, utilizing the specified species unless otherwise authorized by the Project Engineer.

901-2.2

DELETE:

The entire section.

901-2.3

REVISE last paragraph to read as follows:

Fertilizer shall be applied at rates that supply the following amounts of nutrients per acre to the distributed areas of seeding:

<u>NUTRIENTS</u>	<u>POUNDS PER ACRE</u>
Nitrogen	90
Phosphorous (P205)	90
Potassium (K20)	<u>90</u>
TOTAL	270

CONSTRUCTION METHODS

901-3.1

ADD: "ALL perennial weeds and spontaneous vegetation shall be eliminated within the seedbed prior to seeding, using mowing/raking and herbicide. Herbicides used for weed removal shall be as recommended by the seed producer. Based upon actual conditions, it may be necessary for this weed removal to begin up to eight weeks before planting. When all vegetation is dead, the soil shall be tilled and otherwise prepared for planting as specified herein. Weed removal prior to acceptance of the lawn shall be incidental to the Contract.

ADD: to the second Paragraph:

"Soil shall be prepared to have clods no more than 1½ inches on any side to ensure adequate seed-soil contact."

ADD: Seed shall not be placed on ground that is frozen or in any way in a condition that is detrimental to the seed.

Areas shall be de-watered if necessary to accomplish any specified plantings. The method of de-watering shall be approved by the Resident Engineer.

Final grading and site preparation must be inspected and approved by the Resident Engineer prior to any planting.

Seedbed preparation shall commence as soon as practicable prior to planting. After preparation, these areas shall be protected from erosion.

The proposed seeding method shall be stated by the Contractor. The seeding method shall result in a uniform distribution and complete coverage of the entire area to be seeded. If seed drilling is proposed, the seeder shall have an adjustable gate opening provided uniform flow and shall drop the seed directly into place on the prepared seed bed. If the broadcast method is used, within eight hours of seeding, all seeded areas should be rolled at right angles to the slope with a roller, cultipacker or hand tamped to compact the seedbed. Any areas broadcasted shall be sufficiently rolled or tamped to assist proper germination. All seeding equipment shall be calibrated to ensure the proper flow of seeds to deliver the specified quantities. The Contractor shall use only seeding equipment that is designed to plant grasses.

All seeding shall be provided within the planting seasons stated in Section 901-2.1, unless season mixes are prior approved by the Project Engineer and conditions are acceptable for seeding as noted in Section 901-2.1.

Measures to protect planted materials from grazing damage by wildlife shall be recommended and provided by the Contractor.

Installation and maintenance of erosion control measures pertinent to seeding shall be the responsibility of the Contractor. Erosion control measures which may be damaged and/or removed by the Contractor during planting and related work shall be replaced by the Contractor.

If on-site conditions change or are otherwise altered due to circumstances beyond the control of the Contractor, the Owner, and/or the Project Engineer, such that the Specifications and/or drawings are no longer valid, the Contractor shall notify the Resident Engineer so that remedial measures may be undertaken.

901-3.2

DELETE: Entire Section

ADD:

- (a) Description: This work shall consist of furnishing, transporting and installing all seeds, plant or other materials required for:
1. Any remedial operations in conformance with the plans as specified in these especial provisions or as directed by the Engineer.
- (b) General Requirements: The site will be in the following condition:
1. The grade will be shaped to the elevation shown on the plans.
 2. The topsoil will be free of clouds, stones, roots, sticks, rivulets, gullies, crusting, caking and have a soil particle size of no larger than 1".
- (c) Seeding Equipment: Seeding equipment shall meet the following requirements. Any other equipment deemed necessary shall be subject to the approval of the Engineer.
1. Disc: Any disc proposed for the use shall be in a good state of repair with sound, unbroken blades. The disc shall be weighted if necessary to achieve the required tillage depth.
 2. No-Till Planters and Drills: Rangeland type drills and no-till planters shall be designed specifically for the seeding of native grasses and forbs with depth control bands set at 1/4" – 1/8".
 3. Seedbed Preparation: Seedbed preparation methods shall be approved by the Engineer. Cultivation shall be accomplished at such a time that seeding may occur immediately and without delay. No seeds shall be sown until the Seedbed has been approved by the Engineer.

- (d) Seeding Methods: The Contractor shall submit for approval by the Engineer and schedule for seeding and/or planting at least two weeks prior to the scheduled commencement of work. Broadcast seeders will not be allowed. Seeder will be a drill type planter. The Engineer shall examine and then approve any equipment to be used. Prior to starting work, all seeding equipment shall be calibrated and adjusted to sow seeds at the proper seeding rate. Equipment shall be operated in a manner to insure complete coverage of the entire area to be seeded. The Engineer shall be notified 48 hours prior to beginning the seeding operations. Any gaps between areas of growth greater than eight square feet shall be resown and/or replanted
1. No-till or Drill Method: Rolling of the Seedbed will not be required with the use of rangeland type grass drill or no-till planters.

901-3.3

DELETE: Entire Section

901-3.4

ADD: It is essential that the seeds planted herein are watered for one to two months after planting to increase germination rates and seedling survival. The Contractor shall regularly water the seedlings to promote proper germination. It is the Contractor's responsibility to regularly inspect the growth and furnish watering when required. All inspection and watering shall be incidental to seeding.

METHOD OF MEASUREMENT

901-4.1

ADD: Areas of seeding not showing a uniform stand of grass in density and color shall not be approved for payment. Such areas shall be reseeded to the Owner's satisfaction at the Contractor's cost.

BASIS OF PAYMENT

901-5.1

ADD: Payment will be made under:

Item AR901510– Seeding – per acre.

ITEM 905 TOPSOILING

DESCRIPTION

905-1.1

ADD: Topsoil shall be from an off-site source identified by the Contractor and approved by the Resident Engineer. When off-site, no separate payment for excavation at the off-site location or haul from off-site will be made, as the Contractor shall include these costs in the Contract unit price for Topsoil.

MATERIALS

905-2.1

TOPSOIL. Modify the allowed pH to read ... 5.5 pH to 6.5 pH.

Replace the last sentence of the first Paragraph with the following:

At least 90 percent of the material shall pass the No. 10 sieve.

Add the following as the last Paragraph:

Testing shall be performed by the Contractor for both the on-site material and the off-site material, should the on-site material be needed to establish the lines and grades shown on the Construction Plans. Soils testing and modification shall be furnished in accordance with Item 901, as modified by these Special Provisions.

CONSTRUCTION METHODS

905-3.4

PLACING TOPSOIL. Delete the first sentence of the first Paragraph and replace with the following:

The topsoil shall be spread on the prepared areas to receive seeding or sodding. The resulting topsoil layer shall be at least four (4) inches in depth; at the outer limits the 4-inch depth can include the existing topsoil layer not disturbed by the construction.

METHOD OF MEASUREMENT

905-4.1

Delete this Section.

905-4.2

Revise this Section. Topsoil obtained off the site for use in restoration shall be incidental to the contract.

BASIS OF PAYMENT

905-5.1

Replace this Paragraph with the following:

The quantity, determined as provided in Section 905-4.2, will be paid for as Incidental to the Contract for the pay item listed below (Off Site), which price and payment shall be full compensation for furnishing and placing all material and for all labor, haul, borrow excavation, equipment, tools, and incidentals necessary to complete the work prescribed in this item, to the satisfaction of the Engineer.

ITEM 908 MULCHING

DESCRIPTION

908-1.1

ADD: Material used for mulching shall be **Heavy Duty** hydraulic mulch, applied and secured as otherwise provided in the Standard Specifications, regardless of the grade slopes to be mulched.

MATERIALS

908-2.1

DELETE First paragraph and replace with:

Material used for mulching shall be **Heavy Duty** hydraulic mulch, as specified herein, regardless of the grade slopes to be mulched.

Delete Subparagraphs A, B and C.

ADD: to Paragraph D., Hydraulic Mulch:

“Material used for mulching shall be **Heavy Duty** hydraulic mulch, as specified herein, regardless of the grade slopes to be mulched.

CONSTRUCTION METHODS

908-3.1

ADD: Hydraulic mulch shall be applied as specified herein for **Heavy Duty** applications.

BASIS OF PAYMENT

908-5.1

ADD: Payment will be made under:

Item AR908510– Mulching – per acre.

Appendix A
IDA Memorandums

State of Illinois
Department of Transportation
Division of Aeronautics

POLICY MEMORANDUM

April 1, 2010

Springfield

Number 96-1

TO: CONSULTING ENGINEERS

SUBJECT: ITEM 610, STRUCTURAL PORTLAND CEMENT CONCRETE:
JOB MIX FORMULA APPROVAL & PRODUCTION TESTING.

- I. This policy memorandum addresses the Job Mix Formula (JMF) approval process and production testing requirements when Item 610 is specified for an airport construction contract.
- II. PROCESS
 - a. The contractor may submit a mix design with recent substantiating test data or he may submit a mix design generated by the Illinois Division of Highways with recent substantiating test data for approval consideration. The mix design should be submitted to the Resident Engineer.
 - b. The Resident Engineer should verify that each component of the proposed mix meets the requirements set forth under Item 610 of the *Standard Specifications for Construction of Airports* and/or the contract special provisions.
 - c. The mix design should also indicate the following information:
 1. The name, address, and producer/supplier number for the concrete.
 2. The source, producer/supplier number, gradation, quality, and SSD weight for the proposed coarse and fine aggregates.
 3. The source, producer/supplier number, type, and weight of the proposed flyash and/or cement.
 4. The source, producer/supplier number, dosage rate or dosage of all admixtures.
 - d. After completion of Items b and c above, the mix with substantiating test data shall be forwarded to the Division of Aeronautics for approval. Once the mix has been approved, the production testing shall be at the rate in Section III as specified herein.

III. PRODUCTION TESTING

- a. One set of cylinders or beams, depending on the strength specified, shall be cast for acceptance testing for each day the mix is used. In addition, at least one slump and one air test shall be conducted for each day the mix is used. If more than 100 c.y. of the mix is placed in a given day, additional tests at a frequency of 1 per 100 c.y. shall be taken for strength, slump, and air. The concrete shall have a maximum slump of three inches (3") and minimum slump of one inch (1") when tested in accordance with ASTM C-143. The air content of the concrete shall be between 5% and 8% by volume. At no time shall the temperature of the concrete exceed 90 degrees Fahrenheit.
- b. If the total proposed amount of Item 610 Structural Portland Cement Concrete as calculated by the Resident Engineer is less than 50 c.y. for the entire project, the following shall apply:
 - The Resident Engineer shall provide calculations of the quantity of Item 610 to the Division of Aeronautics.
 - One set of cylinders or beams, depending on the strength specified, shall be cast for acceptance testing.
 - One air content and one slump test shall be taken for acceptance testing.
 - The concrete shall have a maximum slump of three inches (3") and minimum of one inch (1") when tested in accordance with ASTM C-143. The air content of the concrete shall be between 5% and 8% by volume. At no time shall the temperature of the concrete exceed 90 degrees Fahrenheit.
- c. The Resident Engineer shall collect actual batch weight tickets for every batch of Item 610 concrete used for the project. The actual batch weight tickets shall be kept with the project records and shall be available upon request of the Department of Transportation.

Steven J. Long, P.E.
Acting Chief Engineer

Supersedes Policy Memorandum 96-1 dated January 1, 2004

State of Illinois
Department of Transportation
Division of Aeronautics

POLICY MEMORANDUM

January 1, 2004	Springfield, Illinois	Number: 2001-1
-----------------	-----------------------	----------------

TO: CONTRACTORS

SUBJECT: REQUIREMENTS FOR COLD WEATHER CONCRETING

I. PURPOSE

- A. This policy memorandum outlines the minimum requirements for cold weather concreting. Cold weather is defined as whenever the average ambient air temperature during day or night drops below 40°F.

II. COLD WEATHER CONCRETING PLAN

- A. The contractor shall submit a cold weather concreting plan to the Engineer for approval. Cold weather concreting operations are not allowed to proceed until the contractor's cold weather concreting plan has been approved by the Engineer.
- B. The contractor's plan shall be in compliance with this memorandum and shall address, as a minimum, the following:
1. Concrete Mix Manufacturing
 2. Concrete Mix Temperature Monitoring
 3. Base Preparation
 4. Concrete Curing and Protection
 5. In Place Concrete Temperature Monitoring
 6. Strength Test Specimens

III. MINIMUM REQUIREMENTS

A. Concrete Mix Manufacturing

1. The contractor must make the necessary adjustments so that the concrete temperature is maintained from 50°F to 90°F for placement. Acceptable methods include:
 - a) Heating the mixing water Note: If the mixing water is to be heated to a temperature above 100°F, the contractor must include a mixing sequence plan to indicate the order that each component of the mix is to be charged into the mixer.

- b) Heating the aggregates Note: The exact method of heating the aggregates shall be included as part of the cold weather concreting plan. Aggregates must be free of ice and frozen lumps. To avoid the possibility of a quick or flash set of the concrete, when either the water or aggregates are heated to above 100°F, they should be combined in the mixer first before the cement is added.

B. Concrete Mix Temperature

1. The contractor shall monitor the mix temperature at the plant and prior to placement in the forms. Mix that does not meet the temperature requirement of 50°F to 90°F shall be rejected for use on the project.

C. Base Preparation

1. Paving or placing concrete on a frozen base, subbase, or subgrade is prohibited.
2. The base, subbase, or subgrade on which the concrete is to be placed shall be thawed and heated to at least 40°F. The method by which the base subbase or subgrade is to be heated shall be indicated in the contractor's cold weather concreting plan. Insulating blankets or heated enclosures may be required.

D. Concrete Protection and Curing

1. In addition to the curing options available in article 501-3.17 (a) (b), (c), and (d) of the Standard Specifications for Construction of Airports, the contractor shall protect the concrete in such a manner as to maintain a concrete temperature of at least 50°F for 10 days.
2. The method of concrete protection shall be by use of insulating layer or heated enclosure around the concrete. The method of protection shall be indicated in the contractor's cold weather concreting plan. When insulating layers are to be used, the thermal resistance to heat transfer (R Value in °F*hr*ft²/BTU) of the insulation material selected, shall be appropriate for the slab thickness being constructed and shall be indicated in the cold weather concreting plan.
3. Appendix A shows a chart and table taken from the American Concrete Institute specification, ACI 306 R Cold Weather Concreting, which may be used by the contractor in selecting the proper insulation (R Value) and insulating material which may be used.

E. In-Place Concrete Temperature Monitoring

1. Once the concrete is in place, the protection method used, must ensure that the concrete temperature does not fall below 50°F for the time period specified in Section (D. 1.) of this Policy Memorandum (10 days).
2. The concrete temperature on the surface and below the surface must be monitored and recorded by the contractor for the duration of the protection period in Section (D. 1.).
3. After the concrete has hardened, surface temperature can be checked with special surface thermometers or with an ordinary thermometer that is kept covered with insulating blankets. The high and low values for each 24-hour period of protection must be measured and recorded.
4. One acceptable method of checking temperature below the concrete surface is given in the Portland Cement Association (PCA) book entitled "Design and Control of Concrete Mixtures" latest edition. The method is indicated below and it should be noted that the thermometer should be capable of recording high and low values for a given 24-hour period.

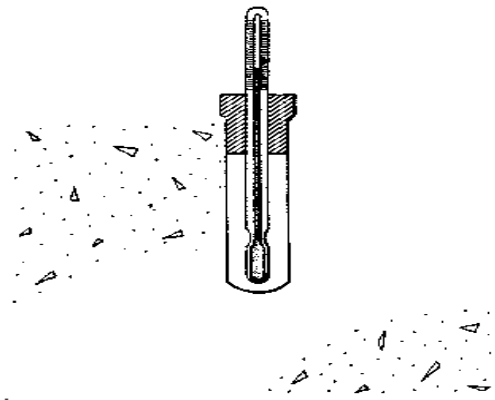

5. The exact method for surface and sub-surface concrete temperature monitoring shall be indicated in the contractor's cold weather concreting plan. The maximum permissible difference between the interior and surface temperature is 35 °F. Adjustments in protection method shall be implemented if the maximum permissible difference is exceeded.

F. Strength specimen handling

1. The Contractor is responsible for making, transporting, and curing all samples (beams or cylinders)
2. The Contractor is required to load the testing machine and dispose of the broken pieces.
3. Onsite, indoor curing facilities, meeting the requirements of ASTM C-31, shall be required for cold weather concreting operations.

4. Sampling for strength specimens shall be according to the Contract Special Provisions. Sampled concrete shall be transported to the indoor curing facilities for the casting of strength specimens.
5. The exact location and description of the curing facilities shall be indicated in the contractor's cold weather concreting plan.
6. The method of transporting concrete sampled from the grade to the curing facilities for casting shall be indicated in the contractor's cold weather concreting plan.

Steven J. Long, P.E.
Acting Chief Engineer

Supersedes Policy Memorandum 2001-1 dated January 1, 2001

APPENDIX A

Minimum exposure temperatures for concrete flatwork placed on the ground for concrete placed & surface temperature maintained at 50 F (10 C) for 3 days on ground at 35 F (2 C)

Slab thickness, in. (m)	Minimum ambient air temperature, deg F (deg C) allowable when insulation having these values of thermal resistance R, hr-ft ² -F/Btu (m ² -K/W), is used			
	R = 2 (0.35)	R = 4 (0.70)	R = 6 (1.06)	R = 8 (1.41)
Cement content = 300 lb/yd ² (178 kg/m ²)				
4 (0.10)	*	*	*	*
8 (0.20)	*	*	*	*
12 (0.31)	*	*	*	*
18 (0.46)	42 (6)	38 (3)	32 (0)	26 (-3)
24 (0.61)	37 (3)	25 (-4)	11 (-12)	-3 (-19)
30 (0.76)	31 (-1)	15 (-9)	-1 (-18)	-17 (-27)
36 (0.91)	31 (-1)	12 (-11)	-5 (-21)	-22 (-30)
Cement content = 400 lb/yd ² (237 kg/m ²)				
4 (0.10)	*	*	*	*
8 (0.20)	*	*	*	*
12 (0.31)	46 (8)	44 (7)	42 (6)	40 (4)
18 (0.46)	36 (2)	22 (-6)	8 (-13)	-6 (-21)
24 (0.61)	28 (-2)	9 (-13)	-10 (-23)	-29 (-34)
30 (0.76)	21 (-6)	0 (-18)	-21 (-29)	-42 (-41)
36 (0.91)	21 (-6)	-4 (-20)	-29 (-34)	-50 (-46)
Cement content = 500 lb/yd ² (296 kg/m ²)				
4 (0.10)	*	*	*	*
8 (0.20)	*	*	*	*
12 (0.31)	42 (6)	36 (2)	30 (-1)	24 (-4)
18 (0.46)	30 (-1)	12 (-11)	-6 (-21)	-22 (-30)
24 (0.61)	21 (-6)	-5 (-21)	-31 (-35)	-50 (-46)
30 (0.76)	16 (-9)	-10 (-23)	-42 (-41)	-74 (-59)
36 (0.91)	16 (-9)	-18 (-28)	-50 (-46)	#
Cement content = 600 lb/yd ² (356 kg/m ²)				
4 (0.10)	*	*	*	*
8 (0.20)	*	*	*	*
12 (0.31)	38 (3)	26 (-3)	14 (-10)	2 (-17)
18 (0.46)	24 (-4)	0 (-18)	-24 (-31)	-48 (-44)
24 (0.61)	14 (-10)	-16 (-27)	-46 (-43)	-82 (-63)
30 (0.76)	10 (-12)	-20 (-29)	-62 (-52)	#
36 (0.91)	7 (-14)	-30 (-34)	#	#

* > 50 F (10 C): additional heat required

<< -60 F (-51 C)

Minimum exposure temperatures for concrete flatwork placed on the ground for concrete placed & surface temperature maintained at 50 F (10 C) for 7 days on ground at 35 F (2 C)

Slab thickness, in. (m)	Minimum ambient air temperature, deg F (deg C) allowable when insulation having these values of thermal resistance R, hr-ft ² -F/Btu (m ² -K/W), is used			
	R = 2 (0.35)	R = 4 (0.70)	R = 6 (1.06)	R = 8 (1.41)
Cement content = 300 lb/yd ² (178 kg/m ²)				
4 (0.10)	*	*	*	*
8 (0.20)	*	*	*	*
12 (0.31)	*	*	*	*
18 (0.46)	46 (8)	42 (6)	36 (2)	30 (-1)
24 (0.61)	40 (4)	31 (-1)	22 (-6)	11 (-12)
30 (0.76)	35 (2)	22 (-6)	7 (-14)	-8 (-22)
36 (0.91)	31 (-1)	13 (-11)	-5 (-21)	-23 (-31)
Cement content = 400 lb/yd ² (237 kg/m ²)				
4 (0.10)	*	*	*	*
8 (0.20)	*	*	*	*
12 (0.31)	*	*	*	*
18 (0.46)	41 (5)	32 (0)	22 (-6)	12 (-11)
24 (0.61)	35 (2)	19 (-7)	-1 (-17)	-15 (-26)
30 (0.76)	28 (-2)	8 (-13)	-14 (-26)	-36 (-38)
36 (0.91)	23 (-5)	-4 (-20)	-29 (-34)	-54 (-48)
Cement content = 500 lb/yd ² (296 kg/m ²)				
4 (0.10)	*	*	*	*
8 (0.20)	*	*	*	*
12 (0.31)	48 (9)	44 (7)	40 (4)	36 (2)
18 (0.46)	36 (2)	22 (-6)	8 (-13)	-6 (-21)
24 (0.61)	28 (-2)	6 (-14)	-16 (-27)	-38 (-39)
30 (0.76)	22 (-6)	-7 (-22)	-36 (-38)	-64 (-53)
36 (0.91)	16 (-9)	-18 (-28)	-50 (-46)	#
Cement content = 600 lb/yd ² (356 kg/m ²)				
4 (0.10)	*	*	*	*
8 (0.20)	*	*	*	*
12 (0.31)	44 (7)	38 (3)	32 (0)	26 (-3)
18 (0.46)	31 (-1)	14 (-10)	-5 (-21)	-24 (-31)
24 (0.61)	22 (-6)	-5 (-21)	-32 (-36)	-61 (-52)
30 (0.76)	14 (-10)	-19 (-28)	-67 (-55)	#
36 (0.91)	7 (-14)	-30 (-34)	#	#

* > 50 F (10 C): additional heat required

< -60 F (-51 C)

Thermal Resistance of Various Insulating Materials

Insulating Material	Thermal resistance "R" for these thicknesses of material*	
	1 in., hr-ft ² -F / Btu	10 mm, m ² -K / W
Boards and slabs		
Expanded polyurethane (R-11 exp.)	6.25	0.438
Expanded polystyrene extruded (R-11 exp.)	5	0.347
Expanded polystyrene extruded, plain	4	0.277
Glass fiber, organic bonded	4	0.277
Expanded polystyrene, molded beads	3.57	0.247
Mineral fiber with resin binder	3.45	0.239
Mineral fiber board, wet felted	2.94	0.204
Sheathing, regular density	2.63	0.182
Cellular glass	2.63	0.182
Laminated paperboard	2	0.139
Particle board (low density)	1.85	0.128
Plywood	1.25	0.087
Blanket		
Mineral fiber, fibrous form processed from rock, slag, or glass	3.23	0.224
Loose fill		
Wood fiber, soft woods	3.33	0.231
Mineral fiber (rock, slag, or glass)	2.5	0.173
Perlite (expanded)	2.7	0.187
Vermiculite (exfoliated)	2.2	0.152
Sawdust or shavings	2.22	0.154

*Values from ASHRAE Handbook of Fundamentals, 1977, American Society of Heating, Refrigerating, and Air-Conditioning Engineers, New York.

State of Illinois
Department of Transportation
Bureau of Materials
Springfield

POLICY MEMORANDUM

Revised: September 15, 2017

18-08.3

This Policy Memorandum supersedes number 18-08.2 dated July 1, 2015

TO: REGIONAL ENGINEERS AND HIGHWAY BUREAU CHIEFS
MANUFACTURERS AND SUPPLIERS OF FINELY DIVIDED MINERALS

SUBJECT: ACCEPTANCE PROCEDURE FOR FINELY DIVIDED MINERALS USED
IN CONCRETE AND OTHER APPLICATIONS

1.0 PURPOSE

To establish procedures whereby materials of mineral origin, furnished by a **Manufacturer** or **Supplier**, will be accepted for use on **Department** projects.

2.0 SCOPE

This procedure is available to all **Manufacturers** or **Suppliers** of domestic and foreign **Finely Divided Minerals**. However, only **Sources** in North America may apply for **Approved Source** status.

3.0 REFERENCES AND AUTHORITY

3.1 **Finely Divided Minerals** used on **Department** projects shall meet the material requirements of the **Specifications**.

3.2 **Fly Ash** used on **Department** projects shall meet the standard physical and chemical requirements of **AASHTO M 295**.

3.3 **Microsilica** used on **Department** projects shall meet the standard physical and chemical requirements of **AASHTO M 307**.

3.4 **High-Reactivity Metakalin** used on **Department** projects shall meet the standard physical and chemical requirements of **AASHTO M 321**, except the fineness shall be a maximum 15% retained on the No. 325 (45 μ m) sieve.

3.5 **Ground Granulated Blast-Furnace Slag** used on **Department** projects shall meet the standard physical and chemical requirements of **AASHTO M 302**, for Grade 100 or Grade 120 material.

3.6 **Dry Expansive Component** used of **Department** projects shall meet the standard physical and chemical requirements of **ASTM C 806**. The minimum restrained expansion shall be 0.04 percent at seven days as determined according to **ASTM C 806**. The maximum restrained expansion shall be 0.18 percent.

- 3.7 Sampling devices which are not according to **ASTM C 311** may be used, if approved by the **Department**. See Attachment A for current sampling devices approved by the **Department**, which are not according to **ASTM C 311**.

4.0 DEFINITIONS

AASHTO - American Association of State Highway and Transportation Officials.

ACCEPTANCE (ACC) SAMPLE - A sample used for accepting/rejecting a **Finely Divided Mineral** prior to use on **Department** projects and/or as unassigned stock for use on future projects. The quantity represented by acceptance samples must be given.

AGENT - One who acts for or as the representative of a **Finely Divided Mineral** company.

APPROVED SOURCE - A source that is approved by the **Bureau** to ship a **Finely Divided Mineral** for immediate use on **Department** projects.

ASTM - American Society for Testing Materials.

BUREAU - Central Bureau of Materials (CBM), Illinois **Department** of Transportation.

CCRL - Cement and Concrete Reference Laboratory.

CEMENT - Portland cement.

COMPOSITE SAMPLE - Combined **Grab Samples** taken at prescribed intervals over a period of time.

DEPARTMENT - Illinois Department of Transportation (IDOT), including its **Districts** and Central Bureau offices.

DISTRICT - District office, Illinois **Department** of Transportation.

DRY EXPANSIVE COMPONENT - A Type G or K dry expansive component as defined in ACI 223R. Per **Department Specifications**, the material is mixed with Type I or II **Cement** and water to produce a paste that increases in volume and makes shrinkage-compensating concrete. **Finely Divided Minerals** may also be used in the concrete mixture.

ENGINEER - Chief Engineer of the **Department** of Transportation of the **State** of Illinois, or authorized representative as defined in Section 101 of the **Standard Specifications**.

FHWA - Federal Highway Administration.

FINELY DIVIDED MINERAL - A finely divided material which has cementitious or pozzolanic properties. Examples are **Fly Ash**, **Microsilica (Silica Fume)**, **Ground Granulated Blast-Furnace (GGBF) Slag**, **High-Reactivity Metakaolin (HRM)**, and **Dry Expansive Component Materials** Type G or K.

FLY ASH - A finely divided residue that results from the combustion of ground or powdered coal, transported from the combustion chamber by exhaust gas, collected by mechanical or electrical means, and stored in stockpiles or bins.

GRAB SAMPLE - A sample secured from a conveyor, from bulk storage, or from a bulk shipment in one operation.

GROUND GRANULATED BLAST-FURNACE (GGBF) SLAG - A glassy granular material, formed when molten blast-furnace slag is rapidly chilled, and then finely ground.

HIGH-REACTIVITY METAKAOLIN (HRM) - A reactive aluminosilicate pozzolan formed by calcining purified kaolinite at a specific temperature range.

INDEPENDANT ASSURANCE (IND) SAMPLE - A sample used to provide an independent check on the reliability of the **Manufacturer's** or **Supplier's** quality control program.

INSPECTOR - The authorized representative of the **Engineer** assigned to make detailed inspection of any or all portions of the work, material, product, etc., as applicable.

INVESTIGATION (INV) SAMPLE - A destination sample used to verify the acceptability of a **Finely Divided Mineral** from a **Source**.

ISO 9000 OR 14000 SERIES - A program of international quality management system standards developed by the International Organization for Standardization (ISO).

MANUFACTURER - A term synonymous with **Producer**.

MICROSILICA - An amorphous silica of high silica content and purity possessing high pozzolanic activity.

NIST - National Institute for Standards and Technology.

PRELIMINARY (PRE) SAMPLE - A sample used to determine, in advance, if the **Finely Divided Mineral** will comply with the **Specifications**.

PROCESS CONTROL (PRO) SAMPLE - A sample used for the purpose of controlling production of a **Finely Divided Mineral** proposed for incorporation into **Department** projects.

PRODUCER - An individual or business entity providing materials and/or products such as a **Finely Divided Mineral** for performance of prescribed work.

REFERENCE MATERIAL - A **Cement** used for the control mortar and corresponding test mortars, of a **Finely Divided Mineral**, to determine its strength activity index.

SOURCE - The name and location of the manufacturing process from which a **Finely Divided Mineral** is obtained.

STATE - The state of Illinois.

SPECIFICATIONS - Specifications for materials; manufactured, fabricated or constructed items; processes; products; designs; conducted test procedures, etc. which includes the **Standard Specifications**, supplemental **Specifications** and recurring special provisions, highway standards, shop drawings, contract plans, project special provisions, **AASHTO Specifications**, **ASTM Specifications**, etc., as applicable.

STANDARD SPECIFICATIONS - The **Department's** Standard Specifications for Road and Bridge Construction.

SUPPLIER - A company that supplies materials or products such as a **Finely Divided Mineral** that it does not manufacture or fabricate.

UNAPPROVED SOURCE - A source that ships a **Finely Divided Mineral** which must be sampled, tested, and approved by the **Bureau** before it is used on **Department** projects.

5.0 FINELY DIVIDED MINERAL ACCEPTANCE PROCEDURES

5.1 Approval of **Finely Divided Minerals** for use on **Department** projects will be according to one of the two procedures outlined in Subsections 5.1.1 and 5.1.2.

5.1.1 **Approved Source Procedure.** A **Manufacturer or Supplier** desiring to avoid delays in the sampling, testing, and approval of a **Finely Divided Mineral** before use on **Department** projects, may, with **Department** approval, qualify a **Source** to ship a **Finely Divided Mineral** for immediate use. Requirements for this procedure are contained in Section 6 of this policy memorandum. The **Bureau** will maintain an ["Approved/Qualified Producer List of Suppliers of Finely Divided Minerals"](#).

5.1.2 **Unapproved Source Procedure.** A **Finely Divided Mineral** from a **Source** other than an **Approved Source** will be sampled, tested, and approved by the **Bureau** for compliance with the requirements in this policy memorandum, before it is used on **Department** projects. Requirements for this procedure are contained in Section 7 of this policy memorandum.

6.0 APPROVED SOURCE PROCEDURE

6.1 A **Manufacturer or Supplier** requesting **Source** approval of a **Finely Divided Mineral** shall provide the following to the **Bureau**:

1. The **Manufacturer's** or **Supplier's** name and location.
2. The **Source** name, location (station), and number of generating units.
3. The name of the **Finely Divided Mineral** and its class, grade, or type.
4. A certification that the **Finely Divided Mineral** meets the applicable requirements of Section 3.

5. A 3-month testing history. For a new **Source** or when the **Supplier** for the **Source** is changed, the 3-month requirement is waived and all available test information at the time of application shall be provided.
6. A copy of the **Manufacturer's** or **Supplier's** quality control program.
7. A copy of the last **CCRL** inspection report of the testing laboratory used by the **Manufacturer** or **Supplier** of the **Finely Divided Mineral**, with documentation of resolution of any discrepancies noted therein. The **Manufacturer** or **Supplier** of **HRM**, **Microsilica**, or **Dry Expansive Component** shall provide a copy of the testing laboratory's **CCRL** inspection report and/or an **ISO 9000** or **14000 Series** certificate. For an alternative quality system program approved by the **Bureau**, a certificate or other documentation shall be provided.
8. A copy of the Safety Data Sheet (SDS) for the **Finely Divided Mineral**.

At the time of application, the **Manufacturer** or **Supplier** shall obtain a **Preliminary (PRE) Grab Sample** of the **Finely Divided Mineral** from current production according to **ASTM C 311**. However, this shall not apply to **Dry Expansive Component**. The **Manufacturer** or **Supplier** shall split the **PRE Sample** and place one portion in an airtight container and deliver it to the **Bureau**. A sample of the **Reference Material** used by the **Manufacturer** or **Supplier** for testing shall be included. The **Manufacturer** or **Supplier** shall assume the cost to deliver the samples to the **Bureau**. The size of the **Bureau's** portion of the **PRE Sample** and the **Reference Material** shall not be less than 6 lb. (3 kg) each and the samples shall be properly identified on form [BMPR CM01 \(link embedded\)](#). The **Manufacturer** or **Supplier** shall test the retained portion of the **PRE Sample** for the standard physical and chemical properties listed in the applicable **Specification** in Section 3. When all tests are completed, the **Manufacturer** or **Supplier** shall complete form [BMPR CM20 \(link embedded\)](#) for **Fly Ash**, [BMPR CM21 \(link embedded\)](#) for **GGBF Slag**, [BMPR CM22 \(link embedded\)](#) for **Microsilica**, or [BMPR CM23 \(link embedded\)](#) for **HRM**, as applicable, and deliver the test results to the **Bureau**.

The **Bureau** will test its portion of the **PRE Grab Sample** with the **Reference Material** for conformance to Section 3. The **Bureau** will compare the results obtained by both laboratories to determine compliance with the allowable difference between two laboratories set forth in the precision statement of each test method. Additional split sample testing will be required if the test results obtained on the **PRE Grab Sample** do not comply with the **Specification** requirements and this policy memorandum.

At the time of application for **Dry Expansive Component**, the **Manufacturer** or **Supplier** shall submit a report prepared by an independent laboratory inspected by **CCRL**. The report shall show the results of **ASTM C 806** conducted no more than five years prior to the time of submittal. The **Dry Expansive Component** shall be used in combination with Type I or II **Cement**. The minimum restrained expansion shall be 0.04 percent at seven days as determined according to **ASTM C 806**. The maximum restrained expansion shall be 0.18 percent.

An **Inspector** from the **Bureau** may conduct a scheduled visit to inspect the laboratory facilities designated by the **Manufacturer** or **Supplier** to test the **Finely Divided Mineral**; the **Source** manufacturing process, the **Source** storage facilities; and the

quality control policies, procedures, and practices used by the **Manufacturer** or **Supplier**. The **Manufacturer** or **Supplier** shall be responsible for payment of transportation, per diem (meals), lodging, and incidental travel costs incurred by the **Bureau Inspector** if the trip from the **Bureau** to the **Manufacturer** or **Supplier**, the **Manufacturer** or **Supplier** inspection, and the return trip to the **Bureau** cannot be completed within one day's normal work hours of 8:00 AM to 4:30 PM. Reimbursement for travel costs shall be provided no later than 30 calendar days after receipt of costs submitted by the **Department**.

The **Bureau** will notify the **Manufacturer** or **Supplier**, in writing, if the request for **Approved Source** status is granted or denied. A request may be denied if the **Manufacturer** or **Supplier** fails to meet the requirements of this policy memorandum, or for other reasons determined by the **Department**.

6.2 **Quality Control Requirements for Approved Sources:**

1. The **Manufacturer** or **Supplier** shall establish and maintain quality control policies and procedures for sampling and testing that are approved by the **Bureau**. The **Bureau** shall be notified of any changes in the **Manufacturer's** or **Supplier's** quality control program.
2. Testing laboratories used by the **Manufacturers** or **Suppliers** of **Fly Ash**, **GGBF Slag**, and **Dry Expansive Component** shall participate in the **CCRL** pozzolan program of the **NIST**, which includes inspection of facilities and testing of proficiency samples. As an alternative to the **CCRL** pozzolan program of the **NIST**, testing laboratories used by the **Manufacturers** or **Suppliers** of **GGBF Slag** and **Dry Expansive Component** may participate in the **CCRL** cement program. As another alternative, testing laboratories used by the **Manufacturers** or **Suppliers** of **Dry Expansive Component** shall have implemented a quality management system based on the **ISO 9000 or 14000 Series** standards in lieu of participating in a **CCRL** program. Testing laboratories used by the **Manufacturers** or **Suppliers** of **Microsilica** or **HRM** shall participate in the **CCRL** pozzolan program of the **NIST** or shall have implemented a quality management system based on the **ISO 9000 or 14000 Series** standards.

Testing laboratories participating in an alternative quality system program that is not listed in the previous paragraph shall submit details of the program for approval by the **Bureau**.

6.3 **Reporting Requirements for Approved Sources:**

1. The **Manufacturer** or **Supplier** shall deliver a test report to the **Bureau** which lists the results of all **Grab** and/or **Composite Samples** taken and tested for the specified reporting period.
2. For **Fly Ash**, the report shall be monthly, and shall be delivered no later than forty calendar days after the end of the month. If the **Fly Ash Source** is sampling more frequently than once per month according to **ASTM C 311**, then the report shall be delivered no later than forty calendar days after the end of the composite date. If the deadline falls on a Saturday, Sunday, or State Holiday, the deadline shall be the next work day.

3. For **GGBF Slag, HRM, Microsilica, and Dry Expansive Component**, the report shall be quarterly and shall be delivered no later than forty calendar days after the end of each quarter. For the purpose of the reports, the quarters shall end March 30, June 30, September 30, and December 31. If the deadline falls on a Saturday, Sunday, or State Holiday, the deadline shall be the next work day.
- 6.4 **Record Requirements for Approved Sources:**
1. Records of production control tests shall be maintained by the **Manufacturer or Supplier** for a minimum period of 5 years, and shall be made available to the **Bureau** upon request.
 2. Copies of bills of lading of quantities of **Finely Divided Minerals** shipped shall be maintained by the **Manufacturer or Supplier** for a minimum period of 3 years, and shall be made available to the **Bureau** upon request. At a minimum, bills of lading shall contain the following information:
 - a. The type of **Finely Divided Mineral**, including class, grade, etc.
 - b. The quantity of shipment.
 - c. The date of shipment.
 - d. The **Manufacturer's or Supplier's** name.
 - e. The **Source** location.
 - f. The shipment's point of origin, if different from the **Source** location.
 - g. The shipment's destination.
 - h. The consignee's name.
 - i. The bill of lading number.
- 6.5 **Sampling and Test Requirements for Approved Sources:**
1. For **Fly Ash**, each February, May, August, and November, the **Supplier** shall obtain a **Process Control (PRO) Grab Sample** according to **ASTM C 311**.
- For **GGBF Slag, HRM, and Microsilica**, each January, April, July, and October, the **Manufacturer or Supplier** shall obtain a **PRO Grab Sample** according to **ASTM C 311**.
- For **Dry Expansive Component**, **PRO Grab Samples** are not required.
- The **PRO Grab Sample** shall be split for testing by the **Manufacturer or Supplier** and the **Bureau**. At this time, a sample of the current **Reference Material** used by the **Manufacturer or Supplier** for testing shall also be split.
- The **Bureau** may require that more frequent **PRO Grab Samples** be obtained and tested. These samples may be requested because of a change in the material, variations in test results between the **Bureau** and **Manufacturer or Supplier**, field test results, or other reasons as determined by the **Bureau**.
- The **Bureau** samples shall be placed in airtight containers, properly identified on form [BMPR CM01 \(link embedded\)](#), and delivered to the **Bureau** no later than the last work day of the month. The **Manufacturer or Supplier** shall assume the cost to

deliver the samples to the **Bureau**. Each **Finely Divided Mineral** sample and **Reference Material** sample shall not be less than 6 lb. (3 kg).

2. The **Manufacturer** or **Supplier** shall test the retained portion of each **PRO Sample**, using the retained portion of the **Reference Material**, for the standard physical and chemical properties listed in the applicable **Specification** in Section 3. When all tests are completed, the **Manufacturer** or **Supplier** shall complete form [BMPR CM20 \(link embedded\)](#) for **Fly Ash**, [BMPR CM21 \(link embedded\)](#) for **GGBF Slag**, [BMPR CM22 \(link embedded\)](#) for **Microsilica**, or [BMPR CM23 \(link embedded\)](#) for **HRM**, as applicable, and deliver the test results to the **Bureau** no later than the last work day of the following month from the date of sample.
3. The test results obtained by the **Manufacturer** or **Supplier** and the **Bureau** on all split samples will be compared for compliance with the allowable differences for two laboratories set forth in the precision statement of each test method and for compliance with Section 3. If significant differences exist in the split sample test results, the **Department** will investigate sampling and test procedures, or require additional comparative sampling to determine the cause of the variation.

6.6 Department Inspections of Approved Sources:

1. An **Inspector** from the **Bureau** may conduct unscheduled visits to each **Approved Source** or one of its terminals. During this visit, the **Inspector** may take or witness the taking of a random **Independent Assurance (IND) Grab Sample** according to **ASTM C 311**. If a sample is taken, the **Inspector** will split the sample and deliver an equal portion to the **Manufacturer** or **Supplier**. The **Manufacturer** or **Supplier** shall test the retained portion of the split sample for the standard physical and chemical properties listed in the applicable **Specification** with the appropriate **Reference Material**. When all tests are completed, the **Manufacturer** or **Supplier** shall complete form [BMPR CM20 \(link embedded\)](#) for **Fly Ash**, [BMPR CM21 \(link embedded\)](#) for **GGBF Slag**, [BMPR CM22 \(link embedded\)](#) for **Microsilica**, or [BMPR CM23 \(link embedded\)](#) for **HRM**, as applicable, and deliver the test results to the **Bureau** no later than the last work day of the following month from the date of sample. The **Bureau** will evaluate the test results obtained on the sample by the **Manufacturer** or **Supplier** according to Subsection 6.5.
2. The **Manufacturer** or **Supplier** shall be responsible for payment of transportation, per diem (meals), lodging, and incidental travel costs incurred by the **Bureau Inspector** if the trip from the **Bureau** to the **Manufacturer** or **Supplier**, the **Manufacturer** inspection, and the return trip to the **Bureau** cannot be completed within one day's normal work hours of 8:00 AM to 4:30 PM. Reimbursement for travel costs shall be provided no later than 30 calendar days after receipt of costs submitted by the **Department**.
3. Random **Investigation (INV) Grab Samples** of the **Finely Divided Minerals** and the project **Cement (Reference Material)** will be obtained according to **ASTM C 311** and **AASHTO T 127**, respectively, at final destination by a representative of the **Department**. The representative will either take or witness the taking of the **INV Samples**. The sampling location and frequency for obtaining **INV Samples** will be determined by the **Bureau** in consultation with the **District** offices.

The **Bureau** will test **INV Samples** to ascertain the results of **Finely Divided Mineral-project Cement (Reference Material)** combinations. To verify that **Finely Divided Minerals** shipped from **Approved Sources** meet the requirements of Section 3, the **Bureau** may also test **INV Samples** with other appropriate **Reference Material**.

6.7 **Approved Source with Multiple Suppliers:**

In some cases an **Approved Source** will establish contract agreements with various **Suppliers** to sell their product. These **Suppliers** typically will use their own trade name for the product. A **Supplier** who desires to be listed on the **Bureau's** approved list shall have the **Approved Source** provide the **Bureau** a copy of the contract agreement. The **Supplier** and product trade name will be listed as long as the **Approved Source** remains in compliance with this policy memorandum. If the **Approved Source** is removed, the **Supplier** has the option to become approved by meeting the requirements for an **Approved Source**.

6.8 **Revocation of Approved Source Status:**

1. Failure of a **Manufacturer** or **Supplier** to meet the requirements of Sections 3 and 6 of this policy memorandum will be sufficient cause to revoke **Approved Source** status. The occurrence of three late submittals in a twelve month period for any of the following: test report (**Grab** or **Composite Samples**), **PRO Sample**, or **PRO** test results; will result in a meeting with the **Manufacturer** or **Supplier**. The **Manufacturer** or **Supplier** will be given an opportunity to submit a plan for corrective action. Failure to correct the late submittal problem will result in revocation of **Approved Source** status. A late submittal will be based on the postmark date. If there is no postmark date, a late submittal will be based on date of receipt by **Bureau**.
2. Failure to resolve significant differences in testing, as indicated by the test results obtained on **PRO** or **IND Samples** split with the **Manufacturer** or **Supplier** will be sufficient cause to revoke **Approved Source** status.
3. Failure of the testing laboratory, used by the **Manufacturer** or **Supplier** of a **Finely Divided Mineral**, to satisfactorily resolve the discrepancies noted in the **CCRL** inspection report, or maintain a quality management system (ISO or alternative quality system program) will be sufficient cause to revoke **Approved Source** status.
4. Revocation of **Approved Source** status will be reported to the **Manufacturer** or **Supplier** in writing.
5. The **Manufacturer** or **Supplier** may re-apply for **Approved Source** status any time after revocation. However, a minimum of 28 days shall have elapsed from the date of revocation before reinstatement will be considered. The actual date of reinstatement is subject to the determination of the **Engineer** that the problem or problems have been corrected.

7.0 UNAPPROVED SOURCE PROCEDURE

7.1 A **Manufacturer** or **Supplier** requesting approval of a **Finely Divided Mineral** from an **Unapproved Source** shall provide the following to the **Bureau**:

1. The **Manufacturer's** or **Supplier's** name and location.
2. The **Source** name, location (station), and number of generating units.
3. The name of the **Finely Divided Mineral** and its class or grade. However, the **Unapproved Source** procedure will not be permitted for **Dry Expansive Component**.
4. A copy of the latest **CCRL** inspection report and proficiency test results for the testing laboratory to be used by the **Manufacturer** or **Supplier**. The testing laboratory may participate in either the **CCRL** pozzolan or cement program. Otherwise, the **Manufacturer** or **Supplier** shall provide documentation for review that shows the testing laboratory has implemented a quality control and management system which is acceptable to the **Bureau**.
5. A current test report, in English, which indicates that the standard physical and chemical properties of the **Finely Divided Mineral** meets the applicable requirements of Section 3.
6. The transportation method and location at which an **Inspector** from the **Bureau** will be able to obtain **Acceptance (ACC) Samples**.
7. If requested by the **Bureau**, the **Manufacturer** or **Supplier** shall sample a 24-hr **Composite Preliminary (PRE) Sample** of the **Finely Divided Mineral** from current shipments according to **ASTM C 311**. The **Manufacturer** shall split the **PRE Sample**. The **Bureau** sample shall be placed in airtight containers, properly identified on form [BMPR CM01 \(link embedded\)](#). A sample of the **Reference Material** used by the **Manufacturer** or **Supplier** for testing shall be included. The **Manufacturer** or **Supplier** shall assume the cost to deliver the **Sample** and **Reference Material** to the **Bureau**. The size of the **Bureau's** portion of the **PRE Sample**, and the **Reference Material** shall each not be less than 6 lb. (3 kg).

The **Manufacturer** or **Supplier** shall test the retained portion of the **PRE Sample** for the standard physical and chemical properties listed in the applicable **Specification** in Section 3 with the appropriate **Reference Material**. When all tests are completed, the **Manufacturer** or **Supplier** shall complete form [BMPR CM20 \(link embedded\)](#) for **Fly Ash**, [BMPR CM21 \(link embedded\)](#) for **GGBF Slag**, [BMPR CM22 \(link embedded\)](#) for **Microsilica**, or [BMPR CM23 \(link embedded\)](#) for **HRM**, as applicable, and deliver the test results to the **Bureau**.

The **Bureau** will test its portion of the **PRE Sample** for conformance to Section 3 with the appropriate **Reference Material**. The **Bureau** will compare the results obtained by both laboratories to determine compliance with the allowable difference between two laboratories set forth in the precision statement of each test method. Additional split sample testing will be required if the test results obtained on the **PRE**

Sample do not comply with the **Specification** requirements and this policy memorandum.

7.2 Sampling and Test Requirements for Unapproved Sources in North America:

1. **Finely Divided Minerals** from an **Unapproved Source** will be sampled, tested, and approved by the **Bureau** before use on **Department** projects. The **Bureau** has the option to affix a seal to secure **Finely Divided Minerals** in storage (e.g. silo, truck, railroad car, or barge) until the **Bureau's** testing is completed.
2. Upon arrival of the **Finely Divided Mineral** to Illinois, an **Inspector** from the **Bureau** will obtain **Acceptance (ACC) Grab Samples** according to ASTM C 311. The **Bureau** will determine the number of representative samples required. The samples will be split by the **Inspector** with the **Manufacturer** or **Supplier** retaining one portion of each. At this time, samples of the current **Reference Material** used by the **Manufacturer** or **Supplier** for testing shall also be obtained.
3. The **Manufacturer** or **Supplier** may request the **Bureau** to sample the **Finely Divided Mineral** and **Reference Material** prior to arrival in Illinois. In the event the request is approved, the **Manufacturer** or **Supplier** shall be responsible for payment of transportation, per diem (meals), lodging, and incidental travel costs incurred by the **Department Inspector**. Reimbursement for travel costs shall be provided no later than 30 calendar days after receipt of costs submitted by the **Department**. If the **Department** determines that it lacks the resources to accomplish out-of-state inspection, the **Finely Divided Mineral** may be sampled and tested according to the procedures in Subsection 7.3.
4. **Acceptance (ACC) Samples** will be tested with the appropriate **Reference Material** by the **Bureau** and **Manufacturer** or **Supplier** according to Subsection 7.1 Item 7 in order for conformance to Section 3 in order to approve the **Finely Divided Mineral** for use on **Department** projects.
5. **Random Investigation (INV) Samples** of **Finely Divided Minerals** may be obtained at final destination by a representative of the **Department**. The representative will either take or witness the taking of the **INV Samples**. **INV Samples** will be **Grab Samples** and will be taken according to ASTM C 311 for the **Finely Divided Mineral** and AASHTO T 127 for the **Cement (Reference Material)**. The sampling location and frequency for obtaining **INV Samples** will be determined by the **Bureau** in consultation with the **District** offices. The **Bureau** will use **INV Samples** to verify that the **Finely Divided Mineral** shipped meets the requirements of Section 3.

7.3 Sampling and Test Requirements for Unapproved Sources Located Outside North America:

1. At the port of entry, an **Agent** of the importer shall obtain a **Preliminary (PRE) Composite Sample** according to ASTM C 311 from each of the vessel's holds containing foreign **Finely Divided Mineral**.

The **Agent** shall split each vessel hold **Composite Sample** and mail one portion to the **Bureau**. The other portion from each vessel hold shall be mailed to the importer's testing laboratory. At this time, samples of the current **Reference**

Material used by the importer's laboratory for testing shall also be mailed to the **Bureau**. The **Bureau** samples shall be placed in airtight containers, properly identified on form [BMPR CM01 \(link embedded\)](#). The size of the **Bureau's** portion of each **Composite Sample** and the accompanying **Reference Material** shall each not be less than 6 lb. (3 kg).

2. An **Agent** of the importer shall obtain a minimum of one **Acceptance (ACC) Grab Sample** according to **ASTM C 311** from each barge of foreign **Finely Divided Mineral** destined for Illinois. The **Agent** shall split each barge **Grab Sample** and mail one portion to the **Bureau**. The other portion shall be mailed to the importer's testing laboratory. At this time, samples of the current **Reference Material** used by the importer's laboratory for testing shall also be mailed to the **Bureau**. Sample containers, identification and size shall be the same as that detailed in item 1 above.
3. The importer of the **Finely Divided Mineral** shall be responsible for all sampling and mailing costs.
4. The importer's laboratory shall test its portion of each vessel and barge sample for the standard physical requirements of the applicable **Specifications**.
5. Upon completion of the tests, the importer shall deliver to the **Bureau** a certification and report that states the **Finely Divided Mineral** in the vessel unloaded at the port of entry and the **Finely Divided Mineral** loaded onto each barge destined for Illinois has been tested by the importer with the appropriate **Reference Material**, and complies with the applicable **Specifications**. As part of the report, the importer shall complete form [BMPR CM20 \(link embedded\)](#) for **Fly Ash**, [BMPR CM21 \(link embedded\)](#) for **GGBF Slag**, [BMPR CM22 \(link embedded\)](#) for **Microsilica**, or [BMPR CM23 \(link embedded\)](#) for **HRM**, as applicable, for each vessel and barge sample tested. The report shall also include for all vessel samples: the name of the vessel, the source of the **Finely Divided Mineral**, each sample's hold number, the date the vessel arrived at the port of entry, and the date the sample was taken. In addition, the report shall include for all barge samples: the barge number, the date the sample was taken, and the quantity of **Finely Divided Mineral** in the barge.
6. The importer shall immediately notify the **Bureau** if a vessel or barge sample fails to meet the applicable **Specification** requirements.
7. The **Bureau** will review the certification and report, and compare the importer's test data to the test data obtained by the **Bureau** on its portion of each split sample.
8. When the certification and report is examined and determined to be correct, the **Bureau** will notify the importer and the **District** offices that the **Finely Divided Mineral** is approved for state projects.
9. Random **Investigation (INV) Samples**, from one or more barges, may be taken by a **Department Inspector** when the barges arrive at the Illinois terminal(s). **INV Samples** will be **Grab Samples** and will be taken according to **ASTM C 311**. At this time, samples of the current **Reference Material** used by the importer's laboratory for testing shall also be mailed to the **Bureau**. The **Bureau** will use **INV Samples** to verify that the **Finely Divided Mineral** meets the requirements of the **Specifications**.

10. The **Department** will reject any foreign **Finely Divided Mineral** tested by the **Bureau**, or the importer, that does not meet the **Specification** requirements. For split samples where one party is within **Specification** and the other party is out of **Specification**, the **Finely Divided Mineral** will be considered out of **Specification** and will be rejected unless the failing test is determined to be flawed by the **Bureau**.

11. Alternative proposals to the sampling and test requirements stated in this subsection will be considered for **Finely Divided Minerals** which have an acceptable quality history, and which have previously been approved by the **Department**. Requests shall be directed to the **Bureau** for approval.

8.0 ACCEPTANCE OF FINELY DIVIDED MINERALS

8.1 **Finely Divided Minerals** will be accepted according to the **Specifications** and this policy memorandum.

8.2 The **Bureau** will maintain an [“Approved/Qualified Producer List of Suppliers of Finely Divided Minerals”](#) on the internet, which will indicate the **Approved Sources** of **Finely Divided Minerals** that meet the requirements of the **Specifications** and this policy memorandum. This list will include the name, location, and **Producer/Supplier** Number of each approved **Manufacturer** or **Supplier** of **Finely Divided Minerals**. Other information as appropriate will also be provided on the list. These **Manufacturers** or **Suppliers** may ship **Finely Divided Minerals** for immediate use on **Department** projects.

8.3 **Finely Divided Minerals** from **Unapproved Sources** will be approved by the **Bureau** before use on **Department** projects.

9.0 REJECTION OF FINELY DIVIDED MINERALS

9.1 A **Finely Divided Mineral** that fails to conform to the requirements of Section 3 of this policy memorandum shall be rejected for use on **Department** projects.

9.2 The **Bureau** will notify the **Manufacturer** or **Supplier** when a **Finely Divided Mineral** is rejected for use on **Department** projects.

10.0 CLOSING NOTICE

Archived versions of this policy memorandum may be examined by contacting the **Bureau**.

The current **Bureau** Chief of Materials has approved this policy memorandum. Signed documents are on file with the **Bureau**.

Vacuum Type Bulk Sampler

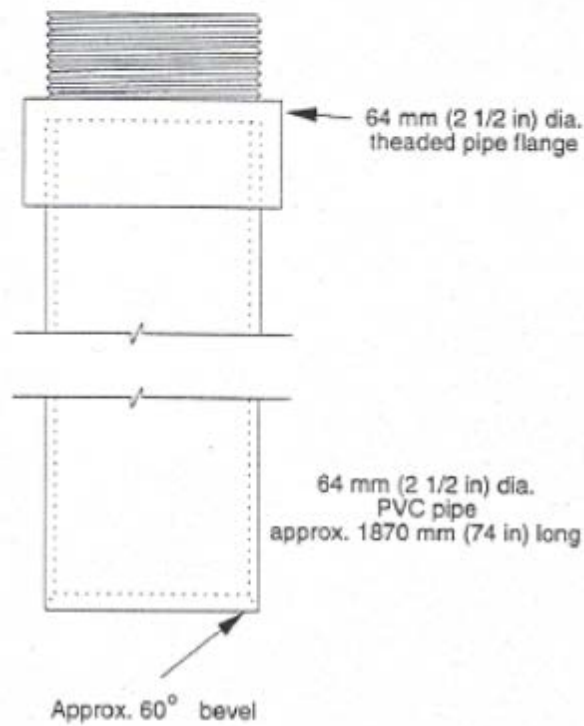
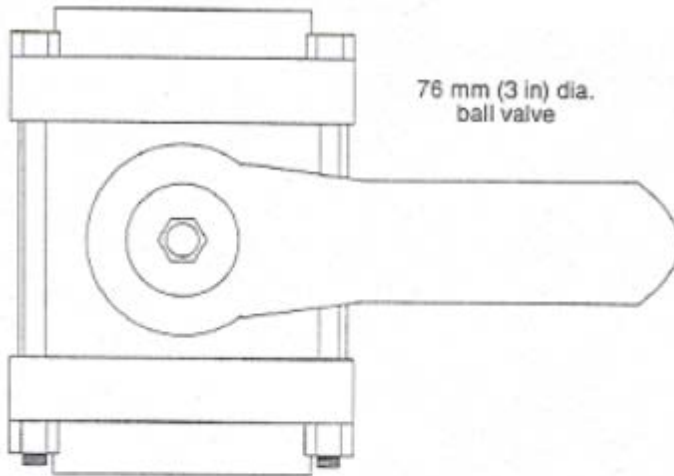

Drop Type Bulk Sampler

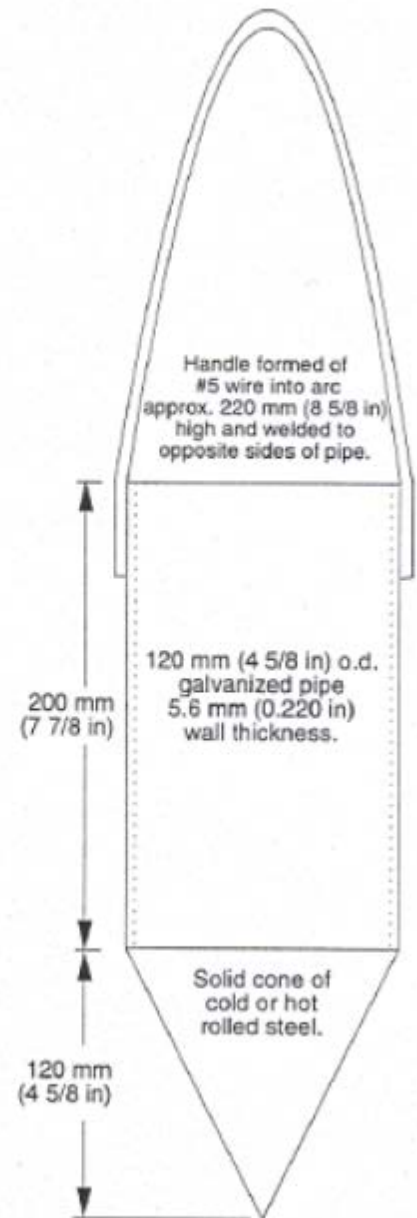

Note:
Total mass weight of sampler not less than 6 kg (13 lb)

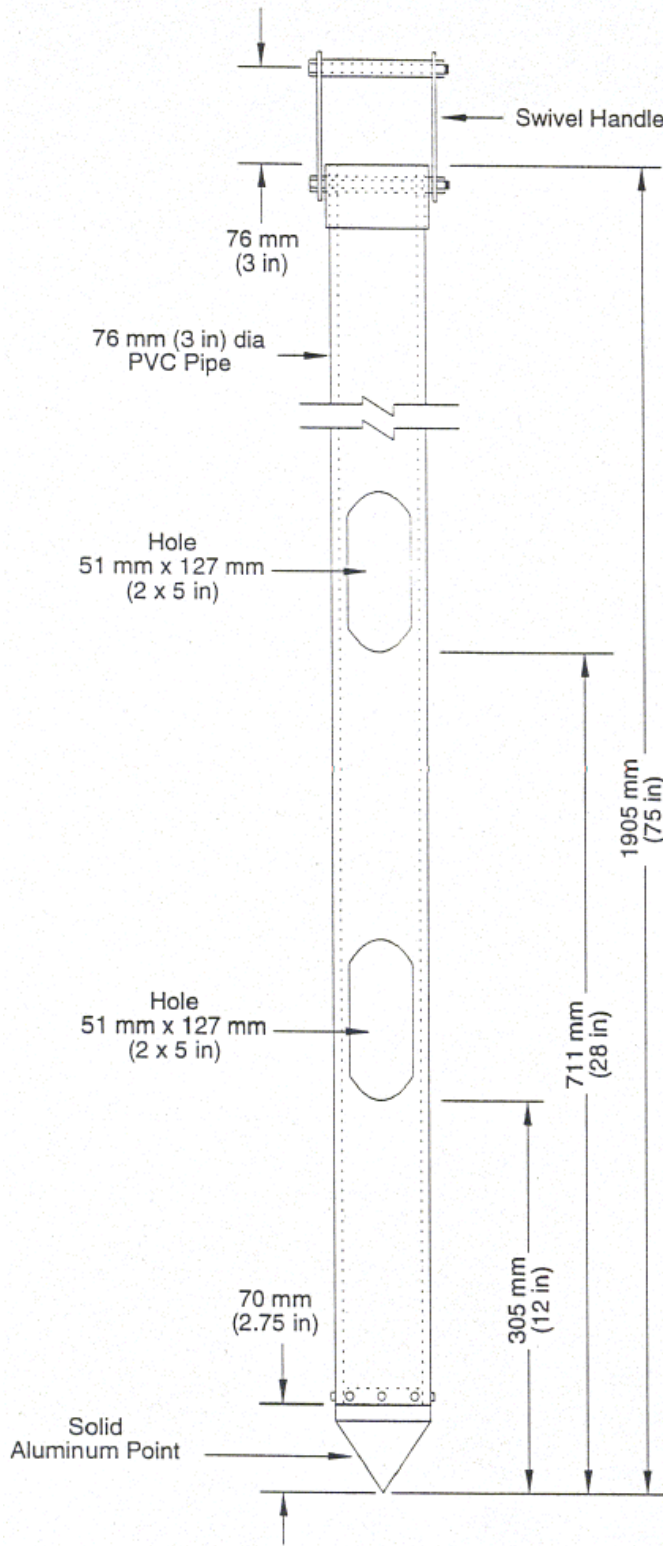

Tube Type Bulk Sampler



CREATE AMAZING.