

MODEL: 4400BELNAMES
 FILE NAME: 719402-14-Driveway/Detail_04.dgn



DESIGNED -	D.M.S.	REVISED -	
DRAWN -	D.M.S.	REVISED -	
CHECKED -	J.R.S.	REVISED -	
DATE -	2/8/2024	REVISED -	

STATE OF ILLINOIS
DEPARTMENT OF TRANSPORTATION

PRIVATE DRIVEWAY DETAILS
WARRENVILLE ROAD

SCALE: AS SHOWN SHEET 4 OF 4 SHEETS STA. TO STA.

F.A.U. RTE.	SECTION	COUNTY	TOTAL SHEETS	SHEET NO.
1479	14-00124-04-BR	DUPAGE	208	101
CONTRACT NO. 61114				
ILLINOIS FED. AID PROJECT				

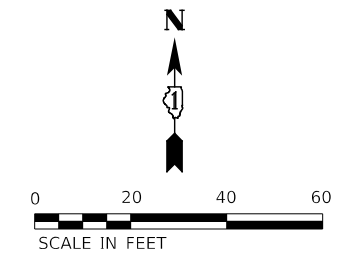

LEGEND

- SECTION CORNER
- QUARTER SECTION CORNER
- SECTION LINE
- QUARTER SECTION LINE
- QUARTER SECTION LINE
- PLATTED LOT LINE
- PROPERTY (DEED) LINE
- APL
- APPARENT PROPERTY LINE
- EXISTING CENTER LINE
- PROPOSED CENTER LINE
- EXISTING RIGHT OF WAY LINE
- PROPOSED RIGHT OF WAY LINE
- EXISTING EASEMENT
- PROPOSED EASEMENT
- PROPOSED TEMPORARY EASEMENT
- EXISTING ACCESS CONTROL LINE
- PROPOSED ACCESS CONTROL LINE
- MEASURED DIMENSION
120.32' (COMP.)
- COMPUTED DIMENSION
120.32'
- RECORD DIMENSION
- EXISTING BUILDING
- IRON PIPE OR ROD FOUND
- "MAG" NAIL SET
- CUT CROSS FOUND OR SET
- "MAG" NAIL SET
- STAKING OF PROPOSED RIGHT OF WAY SET DIVISION OF HIGHWAY'S SURVEY MARKER TO MONUMENT THE POSITION SHOWN, IDENTIFIED BY INSCRIPTION DATA AND SURVEYOR'S PROFESSIONAL NUMBER.
- STAKING OF PROPOSED RIGHT OF WAY IN CULTIVATED AREAS BURIED 1/8 INCH REBAR 20 INCHES BELOW GROUND TO MARK FUTURE SURVEY MARKERS POSITION, IDENTIFIED BY COLORED PLASTIC CAP BEARING THE SURVEYOR'S PROFESSIONAL NUMBER.
- PERMANENT SURVEY MARKER, IDOT STANDARD 667101-02 (TO BE SET BY OTHERS).
- RIGHT OF WAY STAKING PROPOSED TO BE SET.

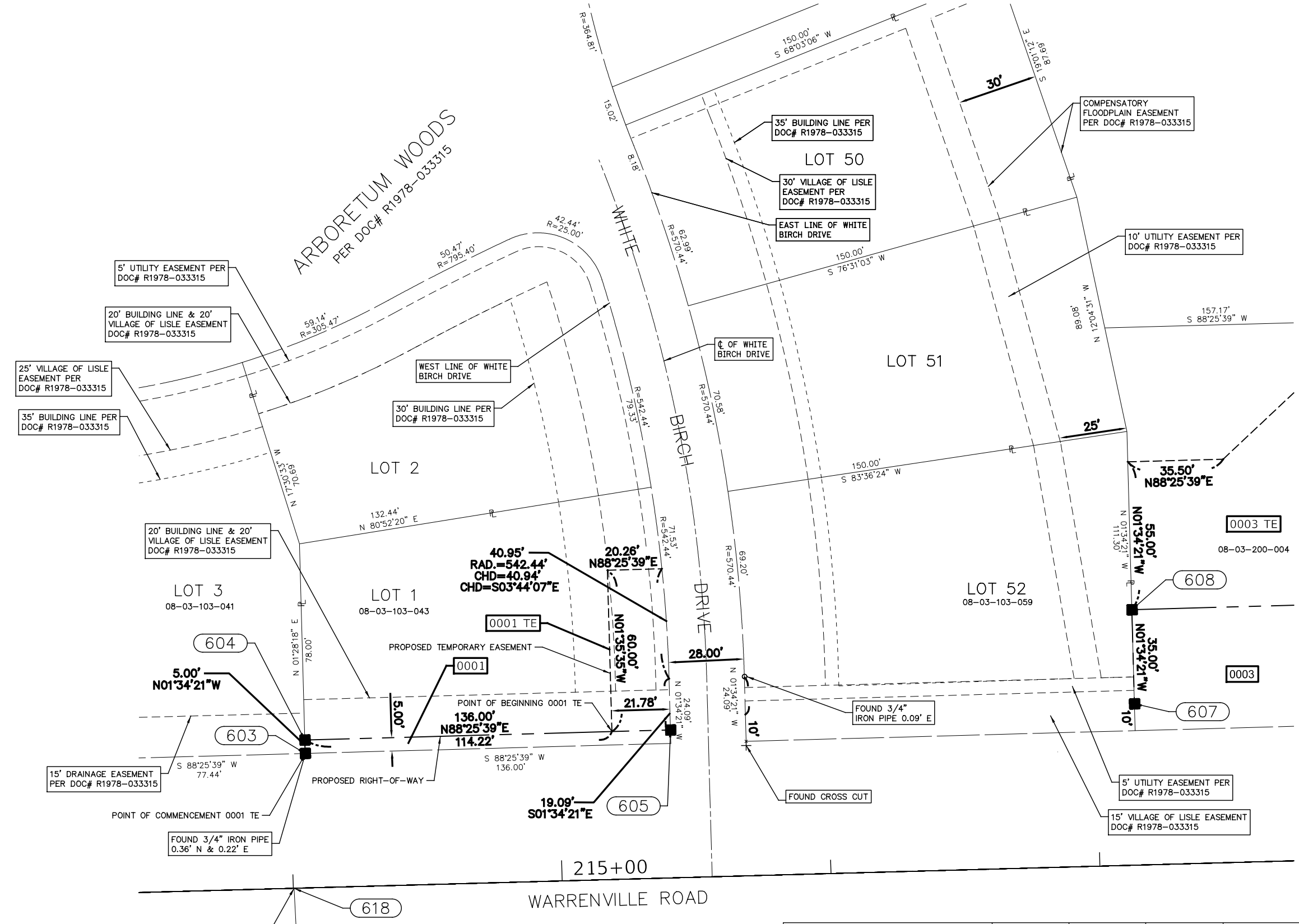

PARCEL NUMBER	OWNER	TOTAL HOLDING (ACRES)	PART TAKEN (ACRES)	REMAINDER (ACRES)	AREA IN EXIST. ROW (ACRES)	EASEMENT (ACRES)	EASEMENT PURPOSE	PERMANENT TAX INDEX NUMBER	PROPERTY ACQUIRED BY
PARCEL 0001 0001 TE	KRISTEN SHAUGER	0.240	0.016	0.224	0.000	0.030	TEMP	08-03-103-043	
PARCEL 0002 0002 TE-A 0002 TE-B	KATHLEEN M BALLEIN	0.310	0.033	0.277	0.000	A=0.039 B=0.030	TEMP	08-03-103-059	

MODEL: 4400BELNAMES; FILE NAME: 7194102; Plt of Highway_eht03_0011.dgn

KNIGHT Member of WSP	DESIGNED -	D.M.S.	REVISED -	12/12/2023 - REM. PARCEL 2
	DRAWN -	D.M.S.	REVISED -	
	CHECKED -	J.R.S.	REVISED -	
	DATE -	2/8/2024	REVISED -	

**STATE OF ILLINOIS
DEPARTMENT OF TRANSPORTATION**

**PLAT OF HIGHWAYS
WARRENVILLE ROAD**

SCALE: AS SHOWN SHEET 1 OF 4 SHEETS STA. TO STA.

F.A.U. RTE.	SECTION	COUNTY	TOTAL SHEETS	SHEET NO.
1479	14-00124-04-BR	DUPAGE	208	102
CONTRACT NO. 61114				
ILLINOIS FED. AID PROJECT				

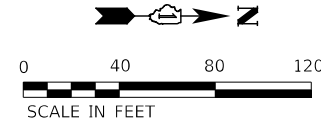

15' VILLAGE OF LISLE EASEMENT
DOC# R1978-033315

5' UTILITY EASEMENT PER
DOC# R1978-033315

POINT OF COMMENCEMENT 0003 TE
POINT OF BEGINNING 0003
POINT OF COMMENCEMENT 0004 TE-A
POINT OF COMMENCEMENT 0004 TE-B
POINT OF COMMENCEMENT 0004

35.00'
N01°34'21"W

POINT OF BEGINNING 0003 TE

POINT OF BEGINNING 0004

POINT OF BEGINNING 0004 TE-A

WARRENVILLE ROAD
1220+00

CL OF WARRENVILLE ROAD
ALSO NORTH LINE OF LOT 3

0004

602

LOT 52
08-03-103-059

LOT 51

LOT 50

LOT 49

LOT 48

LOT 47

LOT 46

LOT 45

LOT 44

LOT 43

5' UTILITY EASEMENT PER
DOC# R1978-033315

COMPENSATORY
FLOODPLAIN EASEMENT
PER DOC# R1978-033315

10' UTILITY EASEMENT PER
DOC# R1978-033315

WEST LINE OF THE NORTHEAST
QUARTER SEC 03-38-10

POINT OF BEGINNING 0004 TE-B

LOT 53
08-03-200-005

ARBORETUM WOODS
PER DOC# R1978-033315

PROP. TEMPORARY EASEMENT

PROP. TEMPORARY EASEMENT

0004 TE-A

0004 TE-B

EAST BRANCH DUPAGE RIVER

08-03-204-012

PROP. RIGHT OF WAY

LEGEND

- SECTION CORNER
- QUARTER SECTION CORNER
- SECTION LINE
- QUARTER SECTION LINE
- QUARTER, QUARTER SECTION LINE
- PLATTED LOT LINE
- PROPERTY (DEED) LINE
- APL
- APPARENT PROPERTY LINE
- EXISTING CENTER LINE
- PROPOSED CENTER LINE
- EXISTING RIGHT OF WAY LINE
- PROPOSED RIGHT OF WAY LINE
- EXISTING EASEMENT
- PROPOSED EASEMENT
- PROPOSED TEMPORARY EASEMENT
- EXISTING ACCESS CONTROL LINE
- PROPOSED ACCESS CONTROL LINE
- MEASURED DIMENSION
- COMPUTED DIMENSION
- RECORD DIMENSION
- EXISTING BUILDING

- IRON PIPE OR ROD FOUND
- "MAG" NAIL SET
- + CUT CROSS FOUND OR SET
- "MAG" NAIL SET
- STAKING OF PROPOSED RIGHT OF WAY SET DIVISION OF HIGHWAY'S SURVEY MARKER TO MONUMENT THE POSITION SHOWN. IDENTIFIED BY INSCRIPTION DATA AND SURVEYOR'S PROFESSIONAL NUMBER.
- M STAKING OF PROPOSED RIGHT OF WAY IN CULTIVATED AREAS BURIED 3/8 INCH REBAR 20 INCHES BELOW GROUND TO MARK FUTURE SURVEY MARKERS POSITION. IDENTIFIED BY COLORED PLASTIC CAP BEARING THE SURVEYOR'S PROFESSIONAL NUMBER.
- ⊙ PERMANENT SURVEY MARKER, IDOT STANDARD 667101-02 (TO BE SET BY OTHERS).
- RIGHT OF WAY STAKING PROPOSED TO BE SET.

PROJECT COORDINATES				
Illinois State Plane, East Zone, NAD 83 (2011)				
602	1872897.72	1053064.38	220+54.08	CL PC
607	1872948.38	1052723.27	217+14.49	-60.00 R
608	1872983.37	1052722.31	217+14.49	-95.00 R
609	1872992.58	1053.057.70	220+50.00	-95.00 R

PARCEL NUMBER	OWNER	TOTAL HOLDING (ACRES)	PART TAKEN (ACRES)	REMAINDER (ACRES)	AREA IN EXIST. ROW (ACRES)	EASEMENT (ACRES)	EASEMENT PURPOSE	PERMANENT TAX INDEX NUMBER	PROPERTY ACQUIRED BY
PARCEL 0003 0003 TE	VILLAGE OF LISLE, A MUNICIPAL CORPORATION	0.530	0.155	0.375	0.000	0.241	TEMP	08-03-200-004	
PARCEL 0004 0004 TE-A 0004 TE-B	THE LISLE PARK DISTRICT, AN ILLINOIS MUNICIPAL CORPORATION	8.410	0.197	8.213	0.000	A=0.234 B=1.239	TEMP	08-03-200-005	

MODEL: 4400BELMAMES
FILE NAME: 719402_Plat of Highway_eh04_0002.dgn

<p>Member of WSP</p>	DESIGNED - D.M.S.	REVISED -12/12/2023 - REM. PARCEL 2
	DRAWN - D.M.S.	REVISED -
	CHECKED - J.R.S.	REVISED -
	DATE - 2/8/2024	REVISED -

STATE OF ILLINOIS
DEPARTMENT OF TRANSPORTATION

PLAT OF HIGHWAYS
WARRENVILLE ROAD

SCALE: AS SHOWN SHEET 2 OF 4 SHEETS STA. TO STA.

F.A.U. RTE.	SECTION	COUNTY	TOTAL SHEETS	SHEET NO.
1479	14-00124-04-BR	DUPAGE	208	103
CONTRACT NO. 61114				
ILLINOIS FED. AID PROJECT				

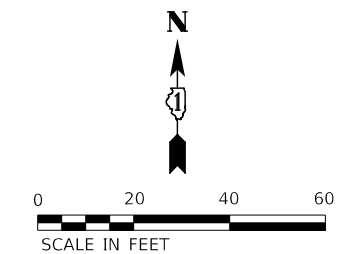

LEGEND

- SECTION CORNER
- QUARTER SECTION CORNER
- SECTION LINE
- QUARTER SECTION LINE
- PLATTED LOT LINE
- PROPERTY (DEED) LINE
- APL
- APPARENT PROPERTY LINE
- EXISTING CENTER LINE
- PROPOSED CENTER LINE
- EXISTING RIGHT OF WAY LINE
- PROPOSED RIGHT OF WAY LINE
- EXISTING EASEMENT
- PROPOSED EASEMENT
- PROPOSED TEMPORARY EASEMENT
- EXISTING ACCESS CONTROL LINE
- PROPOSED ACCESS CONTROL LINE
- MEASURED DIMENSION
- COMPUTED DIMENSION
- RECORD DIMENSION
- EXISTING BUILDING

PROJECT COORDINATES				
Illinois State Plane, East Zone, NAD 83 (2011)				
602	1872897.72	1053064.38	220+54.08	CL PC
609	1872992.58	1053057.70	220+50.00	-95.00 R
610	1872954.03	1053293.52	222+77.72	-63.66 R
620	1872882.72	1053359.91	223+50.28	CL

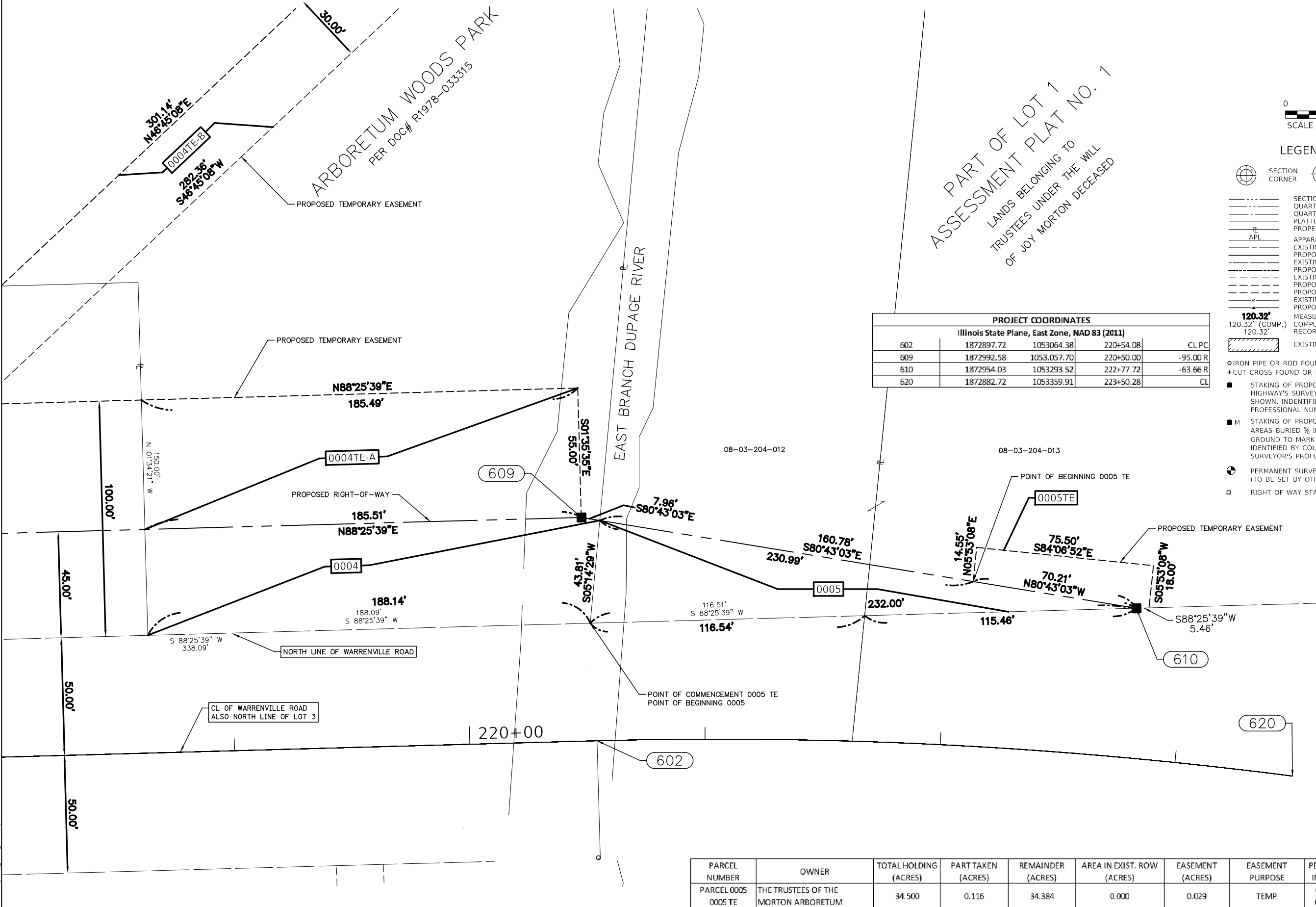

PARCEL NUMBER	OWNER	TOTAL HOLDING (ACRES)	PART TAKEN (ACRES)	REMAINDER (ACRES)	AREA IN EXIST. ROW (ACRES)	EASEMENT (ACRES)	EASEMENT PURPOSE	PERMANENT TAX INDEX NUMBER	PROPERTY ACQUIRED BY
PARCEL 0005 0005 TE	THE TRUSTEES OF THE MORTON ARBORETUM	34.500	0.116	34.384	0.000	0.029	TEMP	08-03-204-012 08-03-204-013	

MODEL: 4400BELMANS; FILE NAME: 719402_Plat of Highway_ehd05_0013.dgn



DESIGNED -	D.M.S.	REVISED -	
DRAWN -	D.M.S.	REVISED -	
CHECKED -	J.R.S.	REVISED -	
DATE -	2/8/2024	REVISED -	

**STATE OF ILLINOIS
DEPARTMENT OF TRANSPORTATION**

**PLAT OF HIGHWAYS
WARRENVILLE ROAD**

SCALE: AS SHOWN SHEET 3 OF 4 SHEETS STA. TO STA.

F.A.U. RTE.	SECTION	COUNTY	TOTAL SHEETS	SHEET NO.
1479	14-00124-04-BR	DUPAGE	208	104
CONTRACT NO. 61114				
ILLINOIS FED. AID PROJECT				

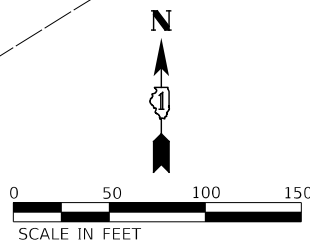
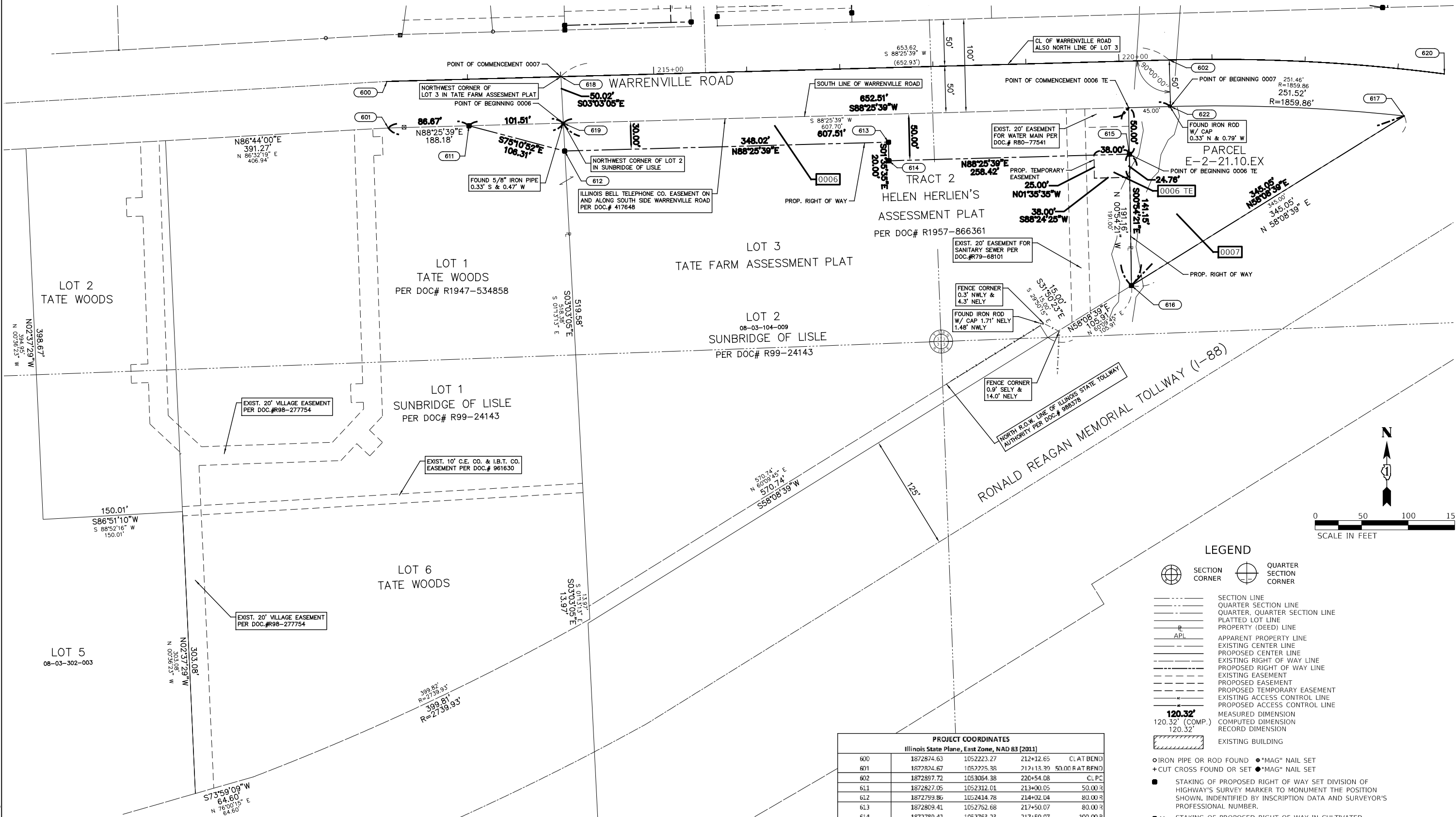

LEGEND

	SECTION CORNER		QUARTER SECTION CORNER
	SECTION LINE		QUARTER SECTION LINE
	PLATTED LOT LINE		PROPERTY (DEED) LINE
	APL		APPARENT PROPERTY LINE
	EXISTING CENTER LINE		PROPOSED CENTER LINE
	EXISTING RIGHT OF WAY LINE		PROPOSED RIGHT OF WAY LINE
	EXISTING EASEMENT		PROPOSED EASEMENT
	PROPOSED TEMPORARY EASEMENT		EXISTING ACCESS CONTROL LINE
	PROPOSED ACCESS CONTROL LINE		MEASURED DIMENSION
	120.32' (COMP.)		120.32'
	EXISTING BUILDING		

PROJECT COORDINATES
Illinois State Plane, East Zone, NAD 83 (2011)

POINT	Easting	Northing	Remarks
600	1872874.63	1052223.27	212+12.65 CL AT BEND
601	1872874.67	1052225.38	212+13.39 50.00' R AT BEND
602	1872897.72	1053064.38	220+54.08 CL PC
611	1872827.05	1052312.01	213+00.05 50.00' R
612	1872799.86	1052414.78	214+02.04 80.00' R
613	1872809.41	1052762.68	217+50.07 80.00' R
614	1872789.42	1052763.23	217+50.07 100.00' R
615	1872796.51	1053021.56	220+08.49 100.00' R
616	1872655.38	1053073.79	220+06.85 241.14' R
617	1872837.49	1053316.87	223+12.39 50.00' R
618	1872879.78	1052410.82	214+00.27 CL
619	1872879.83	1052413.30	214+01.38 50.00' R
620	1872882.72	1053359.91	223+50.28 CL
622	1872847.74	1053055.72	220+54.05 50.00' R

PARCEL NUMBER	OWNER	TOTAL HOLDING (ACRES)	PART TAKEN (ACRES)	REMAINDER (ACRES)	AREA IN EXIST. ROW (ACRES)	EASEMENT (ACRES)	EASEMENT PURPOSE	PERMANENT TAX INDEX NUMBER	PROPERTY ACQUIRED BY
PARCEL 0006	IF ROIS AT LITTLEFIELD, AN ILLINOIS LIMITED LIABILITY COMPANY	12.413	0.572	11.841	0.000	0.022	TEMP	08-03-104-008 08-03-104-009	
PARCEL 0007	THE ILLINOIS STATE TOLL HIGHWAY AUTHORITY	0.674	0.674	0.000	0.000	0.000	N/A		

- IRON PIPE OR ROD FOUND ● "MAG" NAIL SET
- + CUT CROSS FOUND OR SET ● "MAG" NAIL SET
- STAKING OF PROPOSED RIGHT OF WAY SET DIVISION OF HIGHWAY'S SURVEY MARKER TO MONUMENT THE POSITION SHOWN, IDENTIFIED BY INSCRIPTION DATA AND SURVEYOR'S PROFESSIONAL NUMBER.
- M STAKING OF PROPOSED RIGHT OF WAY IN CULTIVATED AREAS BURIED 3/8 INCH REBAR 20 INCHES BELOW GROUND TO MARK FUTURE SURVEY MARKERS POSITION, IDENTIFIED BY COLORED PLASTIC CAP BEARING THE SURVEYOR'S PROFESSIONAL NUMBER.
- PERMANENT SURVEY MARKER, IDOT STANDARD 667101-02 (TO BE SET BY OTHERS).
- RIGHT OF WAY STAKING PROPOSED TO BE SET.

MODEL: 4400BELMANS; FILE NAME: 712402; Plat of Highway - 0106 - 0014.dgn



DESIGNED -	D.M.S.	REVISED -	
DRAWN -	D.M.S.	REVISED -	
CHECKED -	J.R.S.	REVISED -	
DATE -	2/8/2024	REVISED -	

**STATE OF ILLINOIS
DEPARTMENT OF TRANSPORTATION**

**PLAT OF HIGHWAYS
WARRENVILLE ROAD**











SCALE: AS SHOWN SHEET 4 OF 4 SHEETS STA. TO STA.

F.A.U. RTE.	SECTION	COUNTY	TOTAL SHEETS	SHEET NO.
1479	14-00124-04-BR	DUPAGE	208	105

CONTRACT NO. 61114

ILLINOIS FED. AID PROJECT

PAVEMENT MARKING LEGEND

- | | | |
|--|--|--|
|  PAVEMENT MARKING - LINE 4 INCH DOUBLE (YELLOW) WITH RECESSED REFLECTIVE PAVEMENT MARKERS, TWO-WAY AMBER, SPACED AT 40' C-C (ONE-WAY AMBER AT MEDIANS > 4' WIDE) |  PAVEMENT MARKING - LINE 12 INCH SOLID (WHITE) |  PAVEMENT MARKING - LINE 24 INCH SOLID (WHITE) |
|  PAVEMENT MARKING - LINE 4 INCH WHITE SKIP-DASH (10' LINE - 30' SPACE) WITH RECESSED REFLECTIVE PAVEMENT MARKERS, ONE-WAY CRYSTAL, SPACED AT 40' C-C (TWO-WAY AT LOCATIONS WITH BARRIER MEDIAN > 4' WIDE) |  PAVEMENT MARKING - LINE 12 INCH SOLID (YELLOW) |  PAVEMENT MARKING - LETTERS AND SYMBOLS (LARGE SIZE, WHITE) |
|  PAVEMENT MARKING - LINE 4 INCH SOLID (WHITE) |  PAVEMENT MARKING - LINE 6 INCH 2' LINE 6' SPACE (WHITE) | |
|  PAVEMENT MARKING - LINE 4 INCH SOLID (YELLOW) |  PAVEMENT MARKING - LINE 6 INCH SOLID (WHITE) WITH RECESSED REFLECTIVE PAVEMENT MARKERS, ONE-WAY CRYSTAL SPACED AT 40' C-C (TWO-WAY WHITE/RED AT LOCATIONS WITH BARRIER MEDIAN) | |

NOTES

1. THERMOPLASTIC PAVEMENT MARKINGS SHALL BE USED ON ASPHALT PAVEMENT. MODIFIED URETHANE PAVEMENT MARKINGS SHALL BE USED ON CONCRETE PAVEMENT.
2. PAVEMENT MARKINGS AND CROSSWALKS SHALL BE PLACED ACCORDING TO DUPAGE COUNTY DETAIL AND IDOT DISTRICT 1 DETAIL TC-13.
3. RECESSED REFLECTIVE PAVEMENT MARKINGS SHALL BE CONFIGURED AND INSTALLED ACCORDING TO DUPAGE COUNTY DETAIL, EXCEPT SPACING SHALL BE AT 40' C-C THROUGHOUT THE PROJECT LIMITS, OR AS DIRECTED BY THE PROJECT ENGINEER.
4. ALL POST-MOUNTED SIGNS SHALL BE MOUNTED ON TELESCOPING STEEL SIGN SUPPORTS IN ACCORDANCE WITH IDOT HIGHWAY STANDARD 728001 UNLESS OTHERWISE INDICATED.
5. A VERTICAL RETROREFLECTIVE STRIP (3" W X 72" H) WITH AP SHEETING AND COLOR MATCHING THE PRIMARY FACE OF THE SIGN (YELLOW, FLORESCENT YELLOW-GREEN, AND RED ONLY) SHALL BE FURNISHED AND INSTALLED ON THE SIGN SUPPORT AND SHALL BE IN ACCORDANCE WITH THE 2009 MUTCD. THE RETROREFLECTIVE STRIP SHALL ONLY BE APPLIED TO POSTS FOR WARNING (YELLOW, FLORESCENT YELLOW-GREEN) SIGNS AND ONLY THE FOLLOWING REGULATORY (RED) SIGNS: "DO NOT ENTER", "WRONG-WAY", "YIELD" AND "STOP". NO WHITE STRIPS SHALL BE FURNISHED AND/OR INSTALLED. THIS WORK SHALL BE CONSIDERED INCLUDED IN THE UNIT COST FOR TELESCOPING STEEL SIGN SUPPORT OR WOOD SIGN SUPPORT, AND NO ADDITIONAL COMPENSATION WILL BE ALLOWED.

SIGNING LEGEND

- DIRECTION OF TRAFFIC**
 NB - NORTHBOUND
 SB - SOUTHBOUND
 EB - EASTBOUND
 WB - WESTBOUND
- ROADWAY**
 WR - WARRENVILLE ROAD
 WB - WHITE BIRCH DRIVE
- P / REL / REMAIN**
 P - PROPOSED
 REL - RELOCATE
 REMAIN - TO REMAIN
- SIGN PANEL NUMBER**
- MOUNTING TYPE**
 WP - WOOD POST
 TS - TELESCOPING STEEL

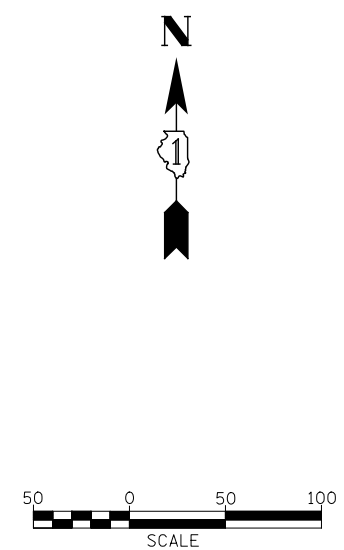
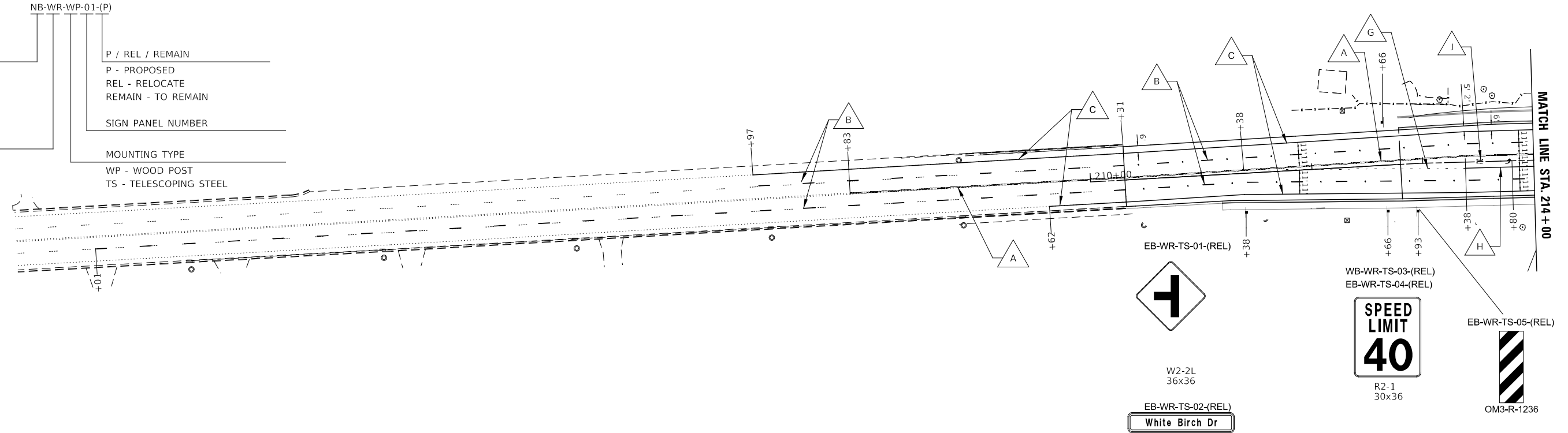

MODEL: 4400BELNAMES
 FILE NAME: 7192024-14-04-BR-RMS-01.dgn

 Member of WSP	DESIGNED - D.M.S.	REVISED -	STATE OF ILLINOIS DEPARTMENT OF TRANSPORTATION	WARRENVILLE ROAD PAVEMENT MARKING AND SIGNING PLANS		F.A.U. RTE.	SECTION	COUNTY	TOTAL SHEETS	SHEET NO.
	DRAWN - D.M.S.	REVISED -				1479	14-00124-04-BR	DUPAGE	208	106
	CHECKED - J.R.S.	REVISED -				CONTRACT NO. 61114				
	DATE - 2/8/2024	REVISED -		SCALE: AS SHOWN SHEET 1 OF 3 SHEETS STA. 200+00 TO STA. 214+00		ILLINOIS FED. AID PROJECT				

PAVEMENT MARKING LEGEND

- A** PAVEMENT MARKING - LINE 4 INCH DOUBLE (YELLOW) WITH RECESSED REFLECTIVE PAVEMENT MARKERS, TWO-WAY AMBER, SPACED AT 40' C-C (ONE-WAY AMBER AT MEDIANS > 4' WIDE)

B PAVEMENT MARKING - LINE 4 INCH WHITE SKIP-DASH (10' LINE - 30' SPACE) WITH RECESSED REFLECTIVE PAVEMENT MARKERS, ONE-WAY CRYSTAL, SPACED AT 40' C-C (TWO-WAY AT LOCATIONS WITH BARRIER MEDIAN > 4' WIDE)

C PAVEMENT MARKING - LINE 4 INCH SOLID (WHITE)

D PAVEMENT MARKING - LINE 4 INCH SOLID (YELLOW)
 - E** PAVEMENT MARKING - LINE 12 INCH SOLID (WHITE)

F PAVEMENT MARKING - LINE 12 INCH SOLID (YELLOW)

G PAVEMENT MARKING - LINE 6 INCH 2' LINE 6' SPACE (WHITE)

H PAVEMENT MARKING - LINE 6 INCH SOLID (WHITE) WITH RECESSED REFLECTIVE PAVEMENT MARKERS, ONE-WAY CRYSTAL SPACED AT 40' C-C (TWO-WAY WHITE/RED AT LOCATIONS WITH BARRIER MEDIAN)
 - I** PAVEMENT MARKING - LINE 24 INCH SOLID (WHITE)

J PAVEMENT MARKING - LETTERS AND SYMBOLS (LARGE SIZE, WHITE)
- *OMIT RECESSED REFLECTIVE MARKERS ON BRIDGE STRUCTURE AND APPROACH SLABS

NOTES

1. THERMOPLASTIC PAVEMENT MARKINGS SHALL BE USED ON ASPHALT PAVEMENT. MODIFIED URETHANE PAVEMENT MARKINGS SHALL BE USED ON CONCRETE PAVEMENT.
2. PAVEMENT MARKINGS AND CROSSWALKS SHALL BE PLACED ACCORDING TO DUPAGE COUNTY DETAIL AND IDOT DISTRICT 1 DETAIL TC-13.
3. RECESSED REFLECTIVE PAVEMENT MARKINGS SHALL BE CONFIGURED AND INSTALLED ACCORDING TO DUPAGE COUNTY DETAIL, EXCEPT SPACING SHALL BE AT 40' C-C THROUGHOUT THE PROJECT LIMITS, OR AS DIRECTED BY THE PROJECT ENGINEER.
4. ALL POST-MOUNTED SIGNS SHALL BE MOUNTED ON TELESCOPING STEEL SIGN SUPPORTS IN ACCORDANCE WITH IDOT HIGHWAY STANDARD 728001 UNLESS OTHERWISE INDICATED.
5. A VERTICAL RETROREFLECTIVE STRIP (3" W X 72" H) WITH AP SHEETING AND COLOR MATCHING THE PRIMARY FACE OF THE SIGN (YELLOW, FLORESCENT YELLOW-GREEN, AND RED ONLY) SHALL BE FURNISHED AND INSTALLED ON THE SIGN SUPPORT AND SHALL BE IN ACCORDANCE WITH THE 2009 MUTCD. THE RETROREFLECTIVE STRIP SHALL ONLY BE APPLIED TO POSTS FOR WARNING (YELLOW, FLORESCENT YELLOW-GREEN) SIGNS AND ONLY THE FOLLOWING REGULATORY (RED) SIGNS: "DO NOT ENTER", "WRONG-WAY", "YIELD" AND "STOP". NO WHITE STRIPS SHALL BE FURNISHED AND/OR INSTALLED. THIS WORK SHALL BE CONSIDERED INCLUDED IN THE UNIT COST FOR TELESCOPING STEEL SIGN SUPPORT OR WOOD SIGN SUPPORT, AND NO ADDITIONAL COMPENSATION WILL BE ALLOWED.

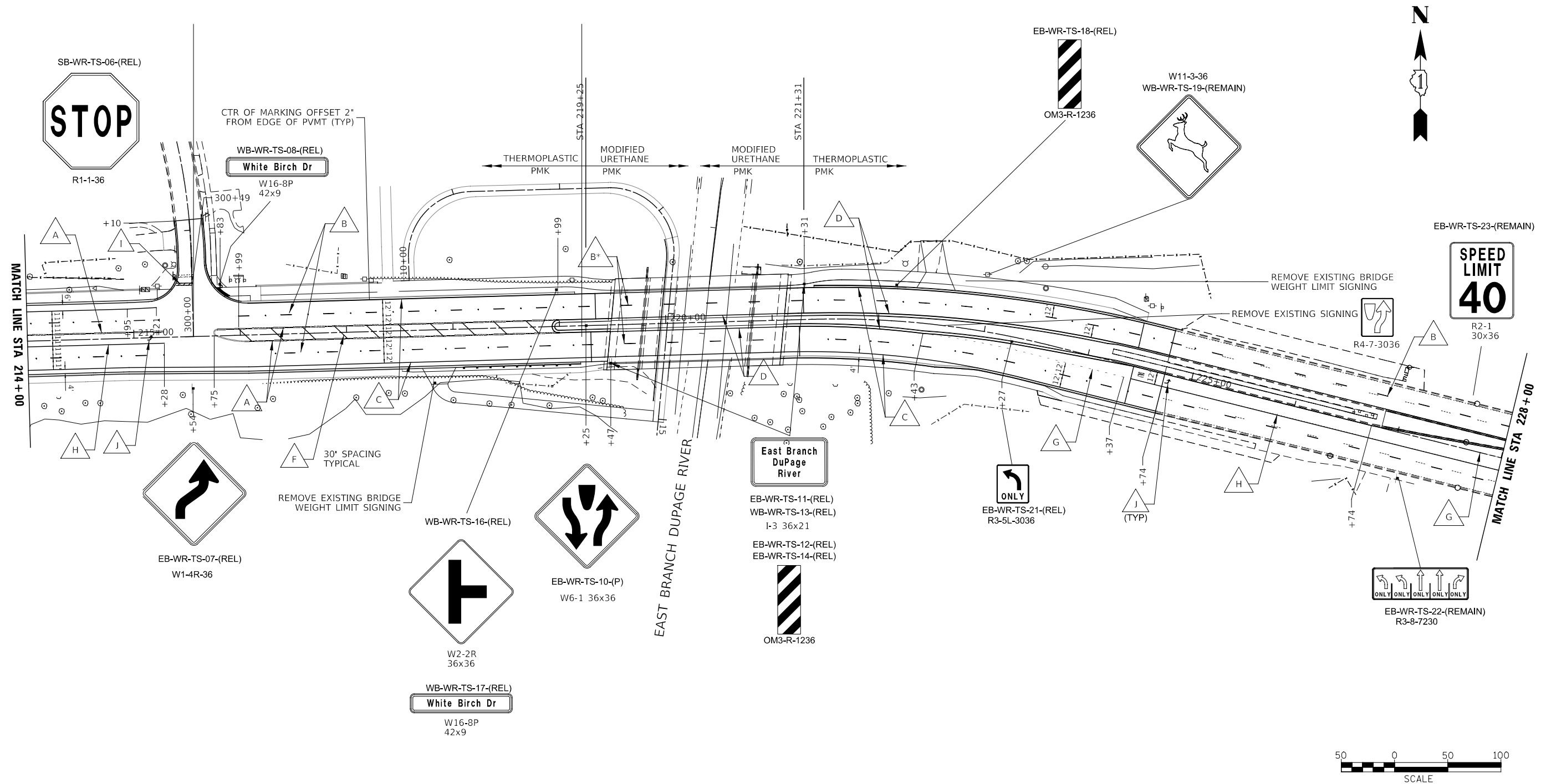

MODEL: 4400BELNAMES
 FILE NAME: 71302024-14-RMS-02.dgn



DESIGNED -	D.M.S.	REVISED -	
DRAWN -	D.M.S.	REVISED -	
CHECKED -	J.R.S.	REVISED -	
DATE -	2/8/2024	REVISED -	











**STATE OF ILLINOIS
DEPARTMENT OF TRANSPORTATION**

**WARRENVILLE ROAD
PAVEMENT MARKING AND SIGNING PLANS**

SCALE: AS SHOWN SHEET 2 OF 3 SHEETS STA. 214+00 TO STA. 228+00

F.A.U. RTE.	SECTION	COUNTY	TOTAL SHEETS	SHEET NO.
1479	14-00124-04-BR	DUPAGE	208	107
CONTRACT NO. 61114				
		ILLINOIS	FED. AID PROJECT	

PAVEMENT MARKING LEGEND

- | | | |
|--|--|--|
|  PAVEMENT MARKING - LINE 4 INCH DOUBLE (YELLOW) WITH RECESSED REFLECTIVE PAVEMENT MARKERS, TWO-WAY AMBER, SPACED AT 40' C-C (ONE-WAY AMBER AT MEDIANS > 4' WIDE) |  PAVEMENT MARKING - LINE 12 INCH SOLID (WHITE) |  PAVEMENT MARKING - LINE 24 INCH SOLID (WHITE) |
|  PAVEMENT MARKING - LINE 4 INCH WHITE SKIP-DASH (10' LINE - 30' SPACE) WITH RECESSED REFLECTIVE PAVEMENT MARKERS, ONE-WAY CRYSTAL, SPACED AT 40' C-C (TWO-WAY AT LOCATIONS WITH BARRIER MEDIAN > 4' WIDE) |  PAVEMENT MARKING - LINE 12 INCH SOLID (YELLOW) |  PAVEMENT MARKING - LETTERS AND SYMBOLS (LARGE SIZE, WHITE) |
|  PAVEMENT MARKING - LINE 4 INCH SOLID (WHITE) |  PAVEMENT MARKING - LINE 6 INCH 2' LINE 6' SPACE (WHITE) | |
|  PAVEMENT MARKING - LINE 4 INCH SOLID (YELLOW) |  PAVEMENT MARKING - LINE 6 INCH SOLID (WHITE) WITH RECESSED REFLECTIVE PAVEMENT MARKERS, ONE-WAY CRYSTAL SPACED AT 40' C-C (TWO-WAY WHITE/RED AT LOCATIONS WITH BARRIER MEDIAN) | |

NOTES

1. THERMOPLASTIC PAVEMENT MARKINGS SHALL BE USED ON ASPHALT PAVEMENT. MODIFIED URETHANE PAVEMENT MARKINGS SHALL BE USED ON CONCRETE PAVEMENT.
2. PAVEMENT MARKINGS AND CROSSWALKS SHALL BE PLACED ACCORDING TO DUPAGE COUNTY DETAIL AND IDOT DISTRICT 1 DETAIL TC-13.
3. RECESSED REFLECTIVE PAVEMENT MARKINGS SHALL BE CONFIGURED AND INSTALLED ACCORDING TO DUPAGE COUNTY DETAIL, EXCEPT SPACING SHALL BE AT 40' C-C THROUGHOUT THE PROJECT LIMITS, OR AS DIRECTED BY THE PROJECT ENGINEER.
4. ALL POST-MOUNTED SIGNS SHALL BE MOUNTED ON TELESCOPING STEEL SIGN SUPPORTS IN ACCORDANCE WITH IDOT HIGHWAY STANDARD 728001 UNLESS OTHERWISE INDICATED.
5. A VERTICAL RETROREFLECTIVE STRIP (3" W X 72" H) WITH AP SHEETING AND COLOR MATCHING THE PRIMARY FACE OF THE SIGN (YELLOW, FLORESCENT YELLOW-GREEN, AND RED ONLY) SHALL BE FURNISHED AND INSTALLED ON THE SIGN SUPPORT AND SHALL BE IN ACCORDANCE WITH THE 2009 MUTCD. THE RETROREFLECTIVE STRIP SHALL ONLY BE APPLIED TO POSTS FOR WARNING (YELLOW, FLORESCENT YELLOW-GREEN) SIGNS AND ONLY THE FOLLOWING REGULATORY (RED) SIGNS: "DO NOT ENTER", "WRONG-WAY", "YIELD" AND "STOP". NO WHITE STRIPS SHALL BE FURNISHED AND/OR INSTALLED. THIS WORK SHALL BE CONSIDERED INCLUDED IN THE UNIT COST FOR TELESCOPING STEEL SIGN SUPPORT OR WOOD SIGN SUPPORT, AND NO ADDITIONAL COMPENSATION WILL BE ALLOWED.

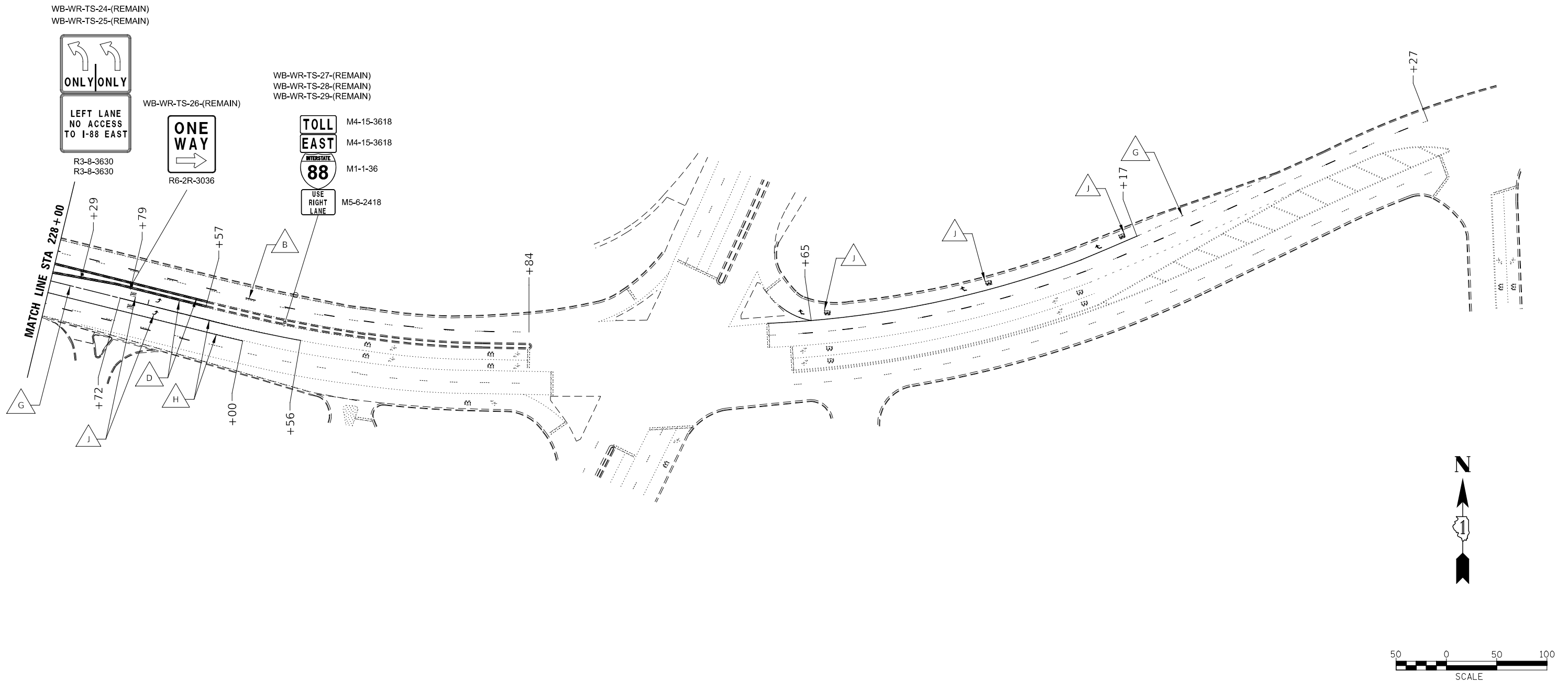

MODEL: 4400BELNAMES
 FILE NAME: 7192025-14-RMS-03.dgn

 Member of WSP	DESIGNED - D.M.S.	REVISED -
	DRAWN - D.M.S.	REVISED -
	CHECKED - J.R.S.	REVISED -
	DATE - 2/8/2024	REVISED -

STATE OF ILLINOIS
DEPARTMENT OF TRANSPORTATION

WARRENVILLE ROAD
PAVEMENT MARKING AND SIGNING PLANS

SCALE: AS SHOWN SHEET 3 OF 3 SHEETS STA. 228+00 TO STA. 243+01

F.A.U. RTE.	SECTION	COUNTY	TOTAL SHEETS	SHEET NO.
1479	14-00124-04-BR	DUPAGE	208	108
CONTRACT NO. 61114				
ILLINOIS FED. AID PROJECT				

SIGNING SCHEDULE								
ALIGNMENT	STATION	LT/RT	PANEL ID	MUTCD CODE	PROPOSED PANEL DIMENSIONS		SIGN PANEL TYPE 1	TELE SIGN SUPPORT
					WIDTH (IN)	HEIGHT (IN)	(SQ FT)	PAY LENGTH (LF)
WARRENVILLE RD	211+38	RT	EB-WR-TS-01-(REL)	W2-2L	36	36	9	16
WARRENVILLE RD	211+38	RT	EB-WR-TS-02-(REL)	W16-8P	42	9	2.625	0
WARRENVILLE RD	212+66	LT	WB-WR-TS-03-(REL)	R2-1	30	36	7.5	8
WARRENVILLE RD	212+66	RT	EB-WR-TS-04-(REL)	R2-1	30	36	7.5	8
WARRENVILLE RD	212+93	RT	EB-WR-TS-05-(REL)	OM3-R	12	36	3	8
WARRENVILLE RD	215+54	RT	EB-WR-TS-07-(REL)	W1-4R	36	36	9	8
WARRENVILLE RD	215+83	LT	WB-WR-TS-08-(REL)	W16-8P	42	9	2.625	8
WARRENVILLE RD	217+40	LT	WB-WR-TS-09-(REL)	OM3-R	12	36	3	8
WARRENVILLE RD	218+99	LT	WB-WR-TS-16-(REL)	W2-2R	36	36	9	8
WARRENVILLE RD	218+99	LT	WB-WR-TS-17-(REL)	W16-8P	42	9	2.625	0
WARRENVILLE RD	219+25	LT/RT	EB-WR-TS-10-(P)	W6-1	36	36	9	8
WARRENVILLE RD	219+47	RT	EB-WR-TS-11-(REL)	1-3	36	21	5.25	8
WARRENVILLE RD	219+47	RT	EB-WR-TS-12-(REL)	OM3-R	12	36	3	0
WARRENVILLE RD	221+31	LT	WB-WR-TS-13-(REL)	1-3	36	21	5.25	8
WARRENVILLE RD	221+31	LT	WB-WR-TS-14-(REL)	OM3-R	12	36	3	0
WARRENVILLE RD	221+32	RT	EB-WR-TS-15-(REL)	OM3-R	12	36	3	8
WARRENVILLE RD	222+15	LT	WB-WR-TS-18-(REL)	OM3-R	12	36	3	0
WARRENVILLE RD	222+94	LT	WB-WR-TS-19-(REMAIN)	W11-3	36	36	9	-
WARRENVILLE RD	223+09	RT	EB-WR-TS-20-(REL)	OM3-R	12	36	3	8
WARRENVILLE RD	223+27	RT	EB-WR-TS-21-(REL)	R3-5L	30	36	7.5	8
WARRENVILLE RD	227+10	RT	EB-WR-TS-22-(REMAIN)	R3-8	72	30	-	-
WARRENVILLE RD	227+77	LT	WB-WR-TS-23-(REMAIN)	R2-1	30	36	-	-
WARRENVILLE RD	228+29	LT	EB-WR-TS-24-(REMAIN)	R3-8	36	30	-	-
WARRENVILLE RD	228+29	LT	EB-WR-TS-25-(REMAIN)	R3-8	36	30	-	-
WARRENVILLE RD	228+79	LT	EB-WR-TS-26-(REMAIN)	R6-2R	30	36	-	-
WARRENVILLE RD	230+37	LT	EB-WR-TS-27-(REMAIN)	M4-15	36	18	-	-
WARRENVILLE RD	230+37	LT	EB-WR-TS-28-(REMAIN)	M4-15	36	18	-	-
WARRENVILLE RD	230+37	LT	EB-WR-TS-29-(REMAIN)	M-1	36	36	-	-
WHITE BIRCH DR	310+49	RT	SB-WB-TS-06-(REL)	R1-1	36	36	9	8

MODEL: 4400BELNAMES
FILE NAME: 719023-11-RMS-200.dgn



DESIGNED -	D.M.S.	REVISED -	
DRAWN -	D.M.S.	REVISED -	
CHECKED -	J.R.S.	REVISED -	
DATE -	2/8/2024	REVISED -	

**STATE OF ILLINOIS
DEPARTMENT OF TRANSPORTATION**

**WARRENVILLE ROAD
SIGNING SCHEDULE**

SCALE: AS SHOWN SHEET 1 OF 3 SHEETS STA. 200+00 TO STA. 214+00

F.A.U. RTE.	SECTION	COUNTY	TOTAL SHEETS	SHEET NO.
1479	14-00124-04-BR	DUPAGE	208	109
			CONTRACT NO. 61114	
		ILLINOIS	FED. AID PROJECT	

NATIVE BMP PLANTING NOTES

GENERAL REQUIREMENTS

- A. ALL PLANTS SPECIFIED, EXCEPT TEMPORARY COVER CROP, SHALL BE NATIVE TO THE NORTH CENTRAL REGION OF THE UNITED STATES.
- B. COVER CROP: SPECIFY NON-INVASIVE SPECIES COMPATIBLE WITH ESTABLISHMENT OF NATIVE PLANTINGS.
- C. NATIVE SEED MIXES: NURSERY PROVIDING SEED MIX MUST BE FROM WITHIN 150-200 MILES OF THE PROPOSED SEEDING LOCATION.
- D. SPECIFY EROSION CONTROL MEASURES FOR SEEDING AND PLANTING.

ESTABLISHMENT REQUIREMENTS

AREAS TO BE PLANTED WITH NATIVE SPECIES SHALL CONFORM TO THE FOLLOWING REQUIREMENTS TO INSURE ESTABLISHMENT.

- A. PLANTING AREAS SHALL HAVE AT LEAST SIX INCHES OF CLEAN UN-COMPACTED TOPSOIL. SUBSOIL SHALL BE LOOSENEED AND TOPSOIL APPLIED TO MINIMIZE COMPACTION.
- B. COVER CROP MAY BE PLANTED IMMEDIATELY AFTER GRADING TO PREVENT EROSION IF CONDITIONS ARE NOT CONDUCIVE FOR NATIVE SPECIES SEEDING. PERMANENT NATIVE SPECIES SHALL BE PLANTED DURING THE FIRST AVAILABLE GROWING SEASON AT THE APPROPRIATE TIME AND CONDITIONS FOR SUCH PLANTINGS.

MODEL: 4400BENAMES
FILE NAME: 71902024-11-landscap_notes.dgn



DESIGNED -	D.M.S.	REVISED -	
DRAWN -	D.M.S.	REVISED -	
CHECKED -	J.R.S.	REVISED -	
DATE -	2/20/2024	REVISED -	







**STATE OF ILLINOIS
DEPARTMENT OF TRANSPORTATION**

**LANDSCAPE PLAN
WARRENVILLE ROAD**

SCALE: AS SHOWN SHEET 1 OF 6 SHEETS STA. TO STA.

F.A.U RTE.	SECTION	COUNTY	TOTAL SHEETS	SHEET NO.
1479	14-00124-04-BR	DUPAGE	208	110
CONTRACT NO. 61114			ILLINOIS FED. AID PROJECT	



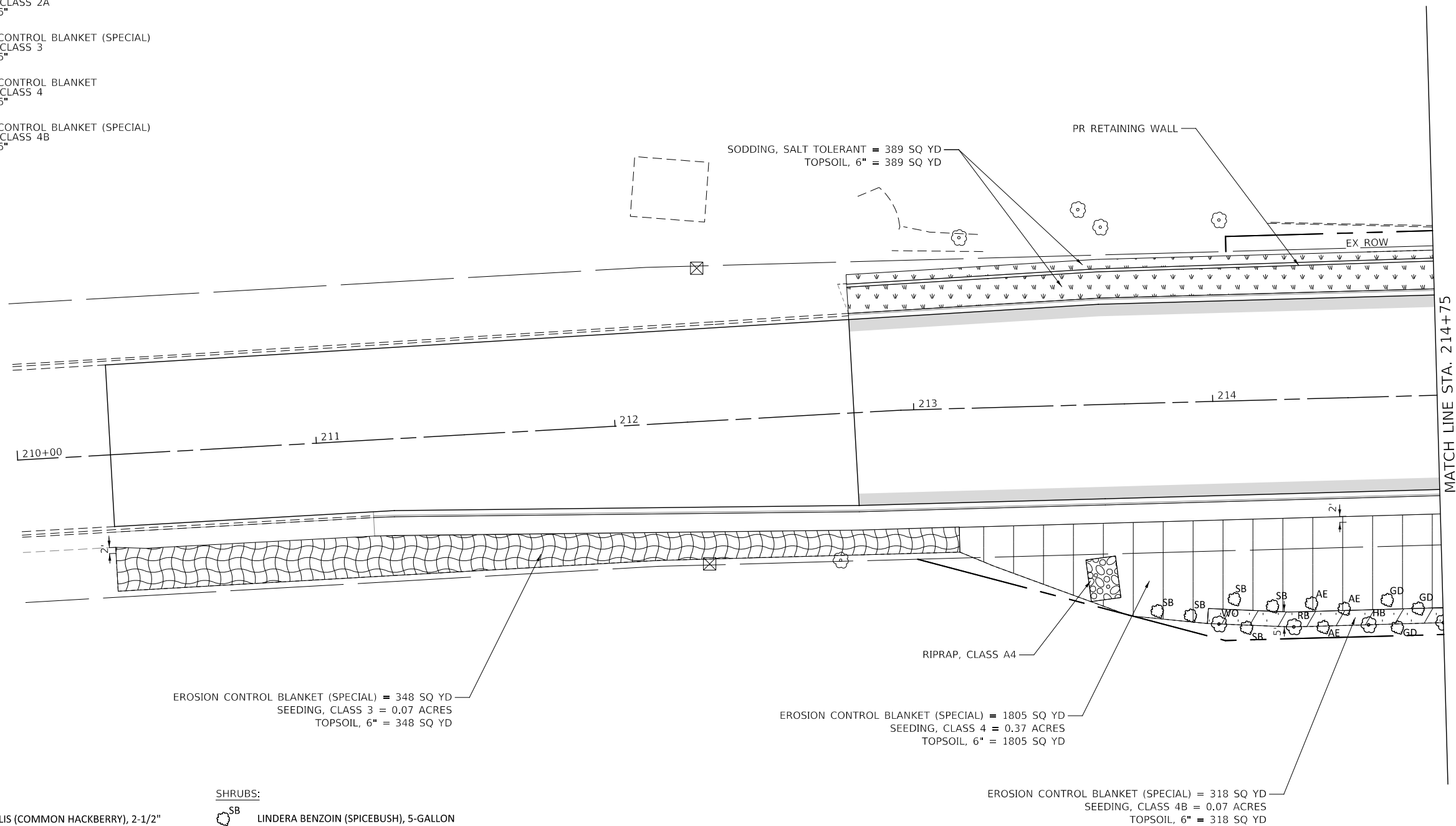

LEGEND:

-  SODDING, SALT TOLERANT
TOPSOIL, 6"
-  EROSION CONTROL BLANKET (SPECIAL)
SEEDING, CLASS 2
TOPSOIL, 6"
-  EROSION CONTROL BLANKET (SPECIAL)
SEEDING, CLASS 2A
TOPSOIL, 6"
-  EROSION CONTROL BLANKET (SPECIAL)
SEEDING, CLASS 3
TOPSOIL, 6"
-  EROSION CONTROL BLANKET
SEEDING, CLASS 4
TOPSOIL, 6"
-  EROSION CONTROL BLANKET (SPECIAL)
SEEDING, CLASS 4B
TOPSOIL, 6"







MATCH LINE STA. 214+75

TREES:

-  HB CELTIS OCCIDENTALIS (COMMON HACKBERRY), 2-1/2"
-  SC PLATANUS OCCIDENTALIS (SYCAMORE), 2-1/2"
-  WO QUERCUS BICOLOR (SWAMP WHITE OAK), 2-1/2"
-  BW TILIA AMERICANA (AMERICAN LINDEN/ BASSWOOD), 2-1/2"
-  RB CERCIS CANADENSIS (EASTERN REDBUD), 2-1/2"

ALL TREES TO BE PLANTED AT A MINIMUM 25' SPACING.

SHRUBS:

-  SB LINDERA BENZOIN (SPICEBUSH), 5-GALLON
-  NB VIBURNUM LENTAGO (NANNYBERRY), 5-GALLON
-  RD CORNUS STOLONIFERA (RED OSIER DOGWOOD), 5-GALLON, SPECIAL
-  GD CORNUS RACEMOSA (GRAY DOGWOOD), 5-GALLON
-  AE SAMBUCUS CANADENSIS (AMERICAN ELDER), 5-GALLON

ALL SHRUBS TO BE PLANTED AT A MINIMUM 10' SPACING.

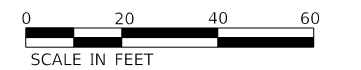

MODEL: 4400BELNAMES
FILE NAME: 7190202-sh-lndscapn_01.dgn



DESIGNED -	D.M.S.	REVISED -	
DRAWN -	D.M.S.	REVISED -	
CHECKED -	J.R.S.	REVISED -	
DATE -	3/11/2024	REVISED -	

**STATE OF ILLINOIS
DEPARTMENT OF TRANSPORTATION**

LANDSCAPE PLAN WARRENVILLE ROAD	
SCALE: 1" = 20'	SHEET 2 OF 6 SHEETS
STA. 210+00	TO STA. 214+75

F.A.U. RTE.	SECTION	COUNTY	TOTAL SHEETS	SHEET NO.
1479	14-00124-04-BR	DUPAGE	208	111
CONTRACT NO. 61114				
		ILLINOIS	FED. AID PROJECT	

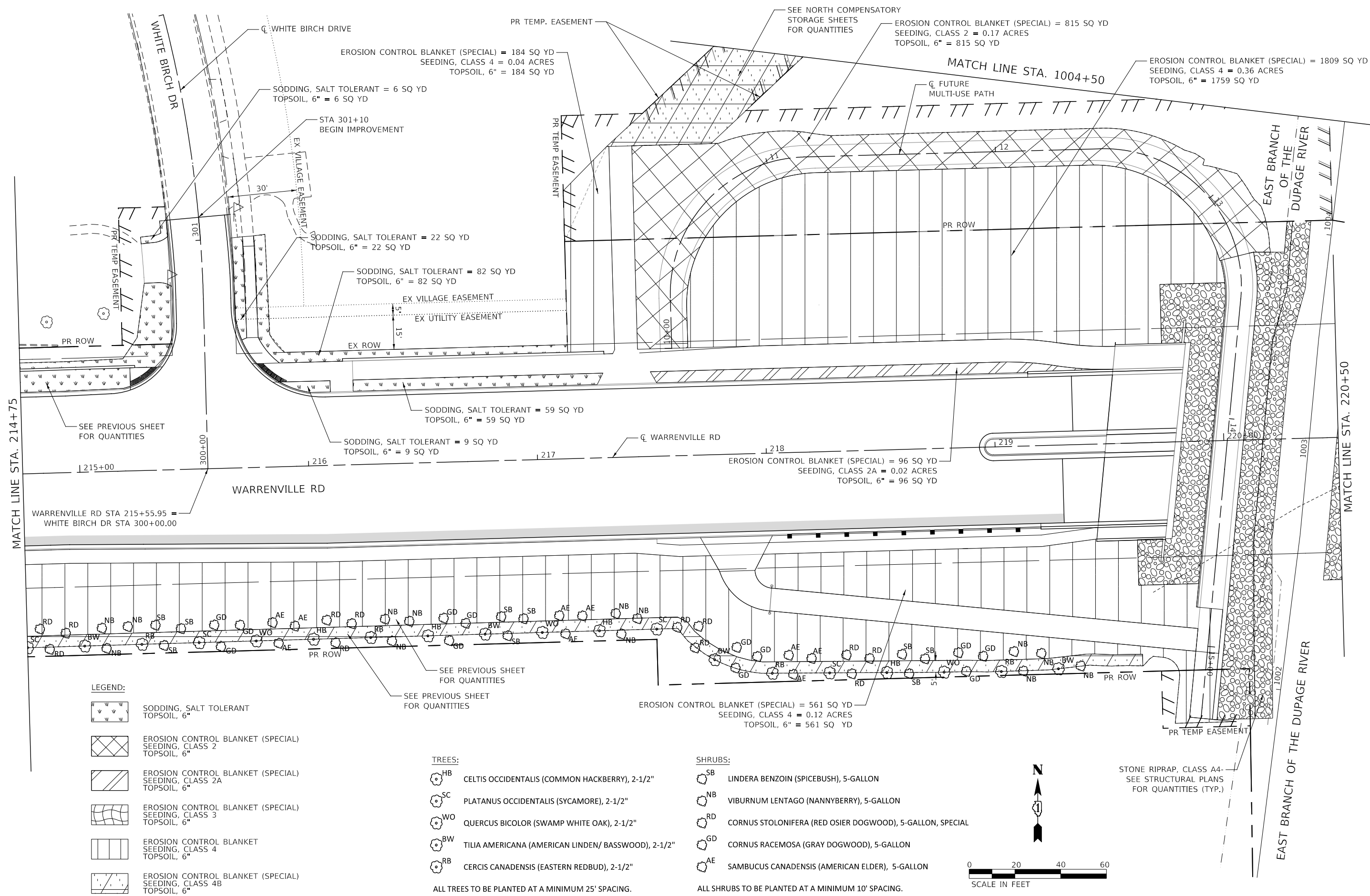

LEGEND:

- SODDING, SALT TOLERANT TOPSOIL, 6"
- EROSION CONTROL BLANKET (SPECIAL) SEEDING, CLASS 2 TOPSOIL, 6"
- EROSION CONTROL BLANKET (SPECIAL) SEEDING, CLASS 2A TOPSOIL, 6"
- EROSION CONTROL BLANKET (SPECIAL) SEEDING, CLASS 3 TOPSOIL, 6"
- EROSION CONTROL BLANKET (SPECIAL) SEEDING, CLASS 4 TOPSOIL, 6"
- EROSION CONTROL BLANKET (SPECIAL) SEEDING, CLASS 4B TOPSOIL, 6"

TREES:

- CELTIS OCCIDENTALIS (COMMON HACKBERRY), 2-1/2"
- PLATANUS OCCIDENTALIS (SYCAMORE), 2-1/2"
- QUERCUS BICOLOR (SWAMP WHITE OAK), 2-1/2"
- TILIA AMERICANA (AMERICAN LINDEN/ BASSWOOD), 2-1/2"
- CERCIS CANADENSIS (EASTERN REDBUD), 2-1/2"

ALL TREES TO BE PLANTED AT A MINIMUM 25' SPACING.

SHRUBS:

- LINDERA BENZOIN (SPICEBUSH), 5-GALLON
- VIBURNUM LENTAGO (NANNYBERRY), 5-GALLON
- CORNUS STOLONIFERA (RED OSIER DOGWOOD), 5-GALLON, SPECIAL
- CORNUS RACEMOSA (GRAY DOGWOOD), 5-GALLON
- SAMBUCUS CANADENSIS (AMERICAN ELDER), 5-GALLON

ALL SHRUBS TO BE PLANTED AT A MINIMUM 10' SPACING.

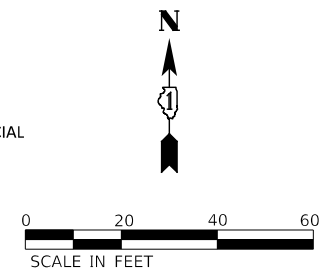

MODEL: 4400BELNAMES
FILE NAME: 719022sh-bndfacep02.dgn



DESIGNED -	D.M.S.	REVISED -	
DRAWN -	D.M.S.	REVISED -	
CHECKED -	J.R.S.	REVISED -	
DATE -	3/11/2024	REVISED -	

**STATE OF ILLINOIS
DEPARTMENT OF TRANSPORTATION**

**LANDSCAPE PLAN
WARRENVILLE ROAD**

SCALE: 1" = 20' SHEET 3 OF 6 SHEETS STA. 214+75 TO STA. 220+50

F.A.U. RTE.	SECTION	COUNTY	TOTAL SHEETS	SHEET NO.
1479	14-00124-04-BR	DUPAGE	208	112
CONTRACT NO. 61114				
		ILLINOIS	FED. AID PROJECT	

MATCH LINE STA. 220+50

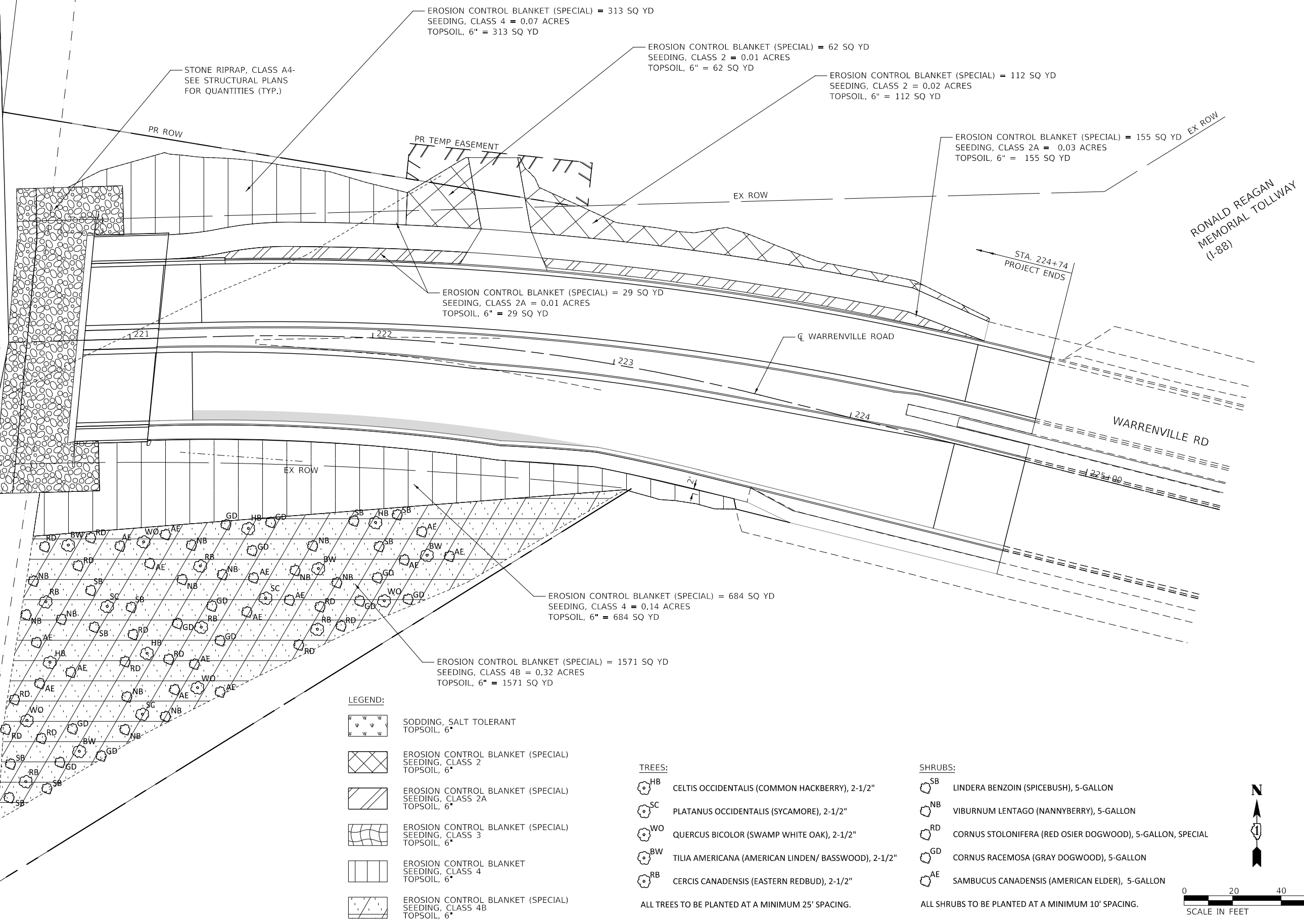

EROSION CONTROL BLANKET (SPECIAL) = 313 SQ YD
SEEDING, CLASS 4 = 0.07 ACRES
TOPSOIL, 6" = 313 SQ YD

EROSION CONTROL BLANKET (SPECIAL) = 62 SQ YD
SEEDING, CLASS 2 = 0.01 ACRES
TOPSOIL, 6" = 62 SQ YD

EROSION CONTROL BLANKET (SPECIAL) = 112 SQ YD
SEEDING, CLASS 2 = 0.02 ACRES
TOPSOIL, 6" = 112 SQ YD

EROSION CONTROL BLANKET (SPECIAL) = 155 SQ YD
SEEDING, CLASS 2A = 0.03 ACRES
TOPSOIL, 6" = 155 SQ YD

EROSION CONTROL BLANKET (SPECIAL) = 29 SQ YD
SEEDING, CLASS 2A = 0.01 ACRES
TOPSOIL, 6" = 29 SQ YD

EROSION CONTROL BLANKET (SPECIAL) = 684 SQ YD
SEEDING, CLASS 4 = 0.14 ACRES
TOPSOIL, 6" = 684 SQ YD

EROSION CONTROL BLANKET (SPECIAL) = 1571 SQ YD
SEEDING, CLASS 4B = 0.32 ACRES
TOPSOIL, 6" = 1571 SQ YD

LEGEND:

- SODDING, SALT TOLERANT
TOPSOIL, 6"
- EROSION CONTROL BLANKET (SPECIAL)
SEEDING, CLASS 2
TOPSOIL, 6"
- EROSION CONTROL BLANKET (SPECIAL)
SEEDING, CLASS 2A
TOPSOIL, 6"
- EROSION CONTROL BLANKET (SPECIAL)
SEEDING, CLASS 3
TOPSOIL, 6"
- EROSION CONTROL BLANKET
SEEDING, CLASS 4
TOPSOIL, 6"
- EROSION CONTROL BLANKET (SPECIAL)
SEEDING, CLASS 4B
TOPSOIL, 6"

TREES:

- CELTIS OCCIDENTALIS (COMMON HACKBERRY), 2-1/2"
- PLATANUS OCCIDENTALIS (SYCAMORE), 2-1/2"
- QUERCUS BICOLOR (SWAMP WHITE OAK), 2-1/2"
- TILIA AMERICANA (AMERICAN LINDEN/ BASSWOOD), 2-1/2"
- CERCIS CANADENSIS (EASTERN REDBUD), 2-1/2"

ALL TREES TO BE PLANTED AT A MINIMUM 25' SPACING.

SHRUBS:

- LINDERA BENZOIN (SPICEBUSH), 5-GALLON
- VIBURNUM LENTAGO (NANNYBERRY), 5-GALLON
- CORNUS STOLONIFERA (RED OSIER DOGWOOD), 5-GALLON, SPECIAL
- CORNUS RACEMOSA (GRAY DOGWOOD), 5-GALLON
- SAMBUCUS CANADENSIS (AMERICAN ELDER), 5-GALLON

ALL SHRUBS TO BE PLANTED AT A MINIMUM 10' SPACING.

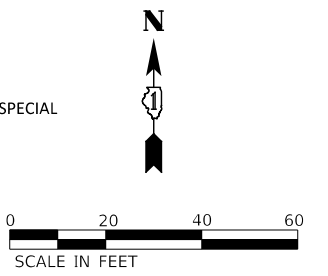

MODEL: 4400BELNAMES
FILE NAME: 719402-shs-landscap-03.dgn



DESIGNED -	D.M.S.	REVISED -	
DRAWN -	D.M.S.	REVISED -	
CHECKED -	J.R.S.	REVISED -	
DATE -	3/11/2024	REVISED -	







STATE OF ILLINOIS
DEPARTMENT OF TRANSPORTATION

LANDSCAPE PLAN
WARRENVILLE ROAD





SCALE: 1" = 20' SHEET 4 OF 6 SHEETS STA. 220+50 TO STA. 225+50

F.A.U. RTE.	SECTION	COUNTY	TOTAL SHEETS	SHEET NO.
1479	14-00124-04-BR	DUPAGE	208	113
CONTRACT NO. 61114				
ILLINOIS		FED. AID PROJECT		

LEGEND:

-  SODDING, SALT TOLERANT TOPSOIL, 6"
-  EROSION CONTROL BLANKET (SPECIAL) SEEDING, CLASS 2 TOPSOIL, 6"
-  EROSION CONTROL BLANKET (SPECIAL) SEEDING, CLASS 2A TOPSOIL, 6"
-  EROSION CONTROL BLANKET (SPECIAL) SEEDING, CLASS 3 TOPSOIL, 6"
-  EROSION CONTROL BLANKET (SPECIAL) SEEDING, CLASS 4 TOPSOIL, 6"
-  EROSION CONTROL BLANKET (SPECIAL) SEEDING, CLASS 4B TOPSOIL, 6"

TREES:

-  HB CELTIS OCCIDENTALIS (COMMON HACKBERRY), 2-1/2"
-  SC PLATANUS OCCIDENTALIS (SYCAMORE), 2-1/2"
-  WO QUERCUS BICOLOR (SWAMP WHITE OAK), 2-1/2"
-  BW TILIA AMERICANA (AMERICAN LINDEN/ BASSWOOD), 2-1/2"
-  RB CERCIS CANADENSIS (EASTERN REDBUD), 2-1/2"

ALL TREES TO BE PLANTED AT A MINIMUM 25' SPACING.

SHRUBS:

-  SB LINDERA BENZOIN (SPICEBUSH), 5-GALLON
-  NB VIBURNUM LENTAGO (NANNYBERRY), 5-GALLON
-  RD CORNUS STOLONIFERA (RED OSIER DOGWOOD), 5-GALLON, SPECIAL
-  GD CORNUS RACEMOSA (GRAY DOGWOOD), 5-GALLON
-  AE SAMBUCUS CANADENSIS (AMERICAN ELDER), 5-GALLON

ALL SHRUBS TO BE PLANTED AT A MINIMUM 10' SPACING.

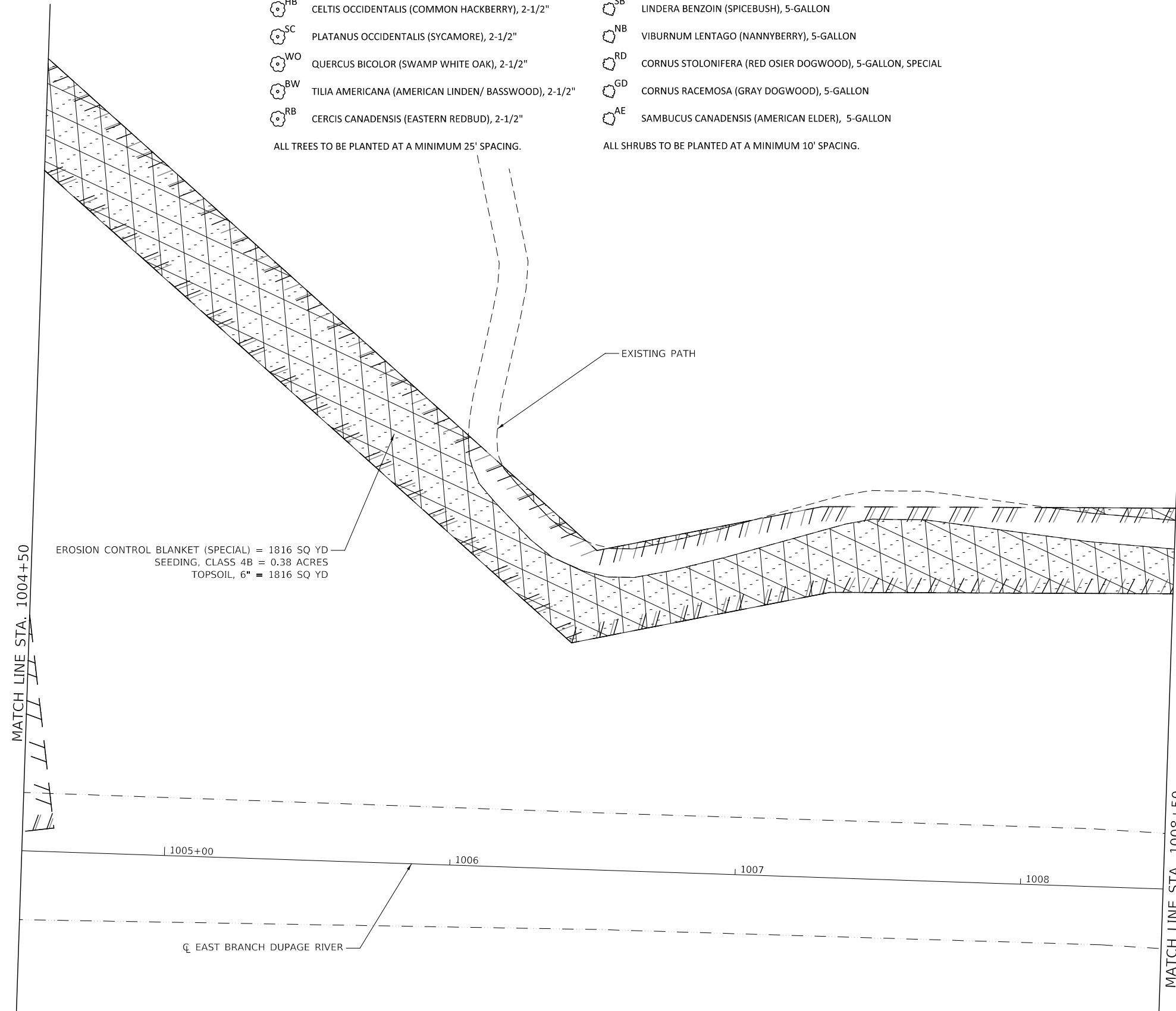

MODEL: 4400BELNAMES
 FILE NAME: 719202sch-bndfrceap_04.dgn



DESIGNED -	D.M.S.	REVISED -	
DRAWN -	D.M.S.	REVISED -	
CHECKED -	J.R.S.	REVISED -	
DATE -	3/11/2024	REVISED -	

**STATE OF ILLINOIS
DEPARTMENT OF TRANSPORTATION**

LANDSCAPE PLAN NORTH COMPENSATORY STORAGE			
SCALE: 1" = 20'	SHEET 5 OF 6 SHEETS	STA. 1004+50 TO STA. 1008+50	

F.A.U. RTE.	SECTION	COUNTY	TOTAL SHEETS	SHEET NO.
1479	14-00124-04-BR	DUPAGE	208	114
CONTRACT NO. 61J14				
ILLINOIS FED. AID PROJECT				

- TREES:**
- HB CELTIS OCCIDENTALIS (COMMON HACKBERRY), 2-1/2"
 - SC PLATANUS OCCIDENTALIS (SYCAMORE), 2-1/2"
 - WO QUERCUS BICOLOR (SWAMP WHITE OAK), 2-1/2"
 - BW TILIA AMERICANA (AMERICAN LINDEN/ BASSWOOD), 2-1/2"
 - RB CERCIS CANADENSIS (EASTERN REDBUD), 2-1/2"

ALL TREES TO BE PLANTED AT A MINIMUM 25' SPACING.

- SHRUBS:**
- SB LINDERA BENZOIN (SPICEBUSH), 5-GALLON
 - NB VIBURNUM LENTAGO (NANNYBERRY), 5-GALLON
 - RD CORNUS STOLONIFERA (RED OSIER DOGWOOD), 5-GALLON, SPECIAL
 - GD CORNUS RACEMOSA (GRAY DOGWOOD), 5-GALLON
 - AE SAMBUCUS CANADENSIS (AMERICAN ELDER), 5-GALLON

ALL SHRUBS TO BE PLANTED AT A MINIMUM 10' SPACING.

- LEGEND:**
- SODDING, SALT TOLERANT TOPSOIL, 6"
 - EROSION CONTROL BLANKET (SPECIAL) SEEDING, CLASS 2 TOPSOIL, 6"
 - EROSION CONTROL BLANKET (SPECIAL) SEEDING, CLASS 2A TOPSOIL, 6"
 - EROSION CONTROL BLANKET (SPECIAL) SEEDING, CLASS 3 TOPSOIL, 6"
 - EROSION CONTROL BLANKET SEEDING, CLASS 4 TOPSOIL, 6"
 - EROSION CONTROL BLANKET (SPECIAL) SEEDING, CLASS 4B TOPSOIL, 6"

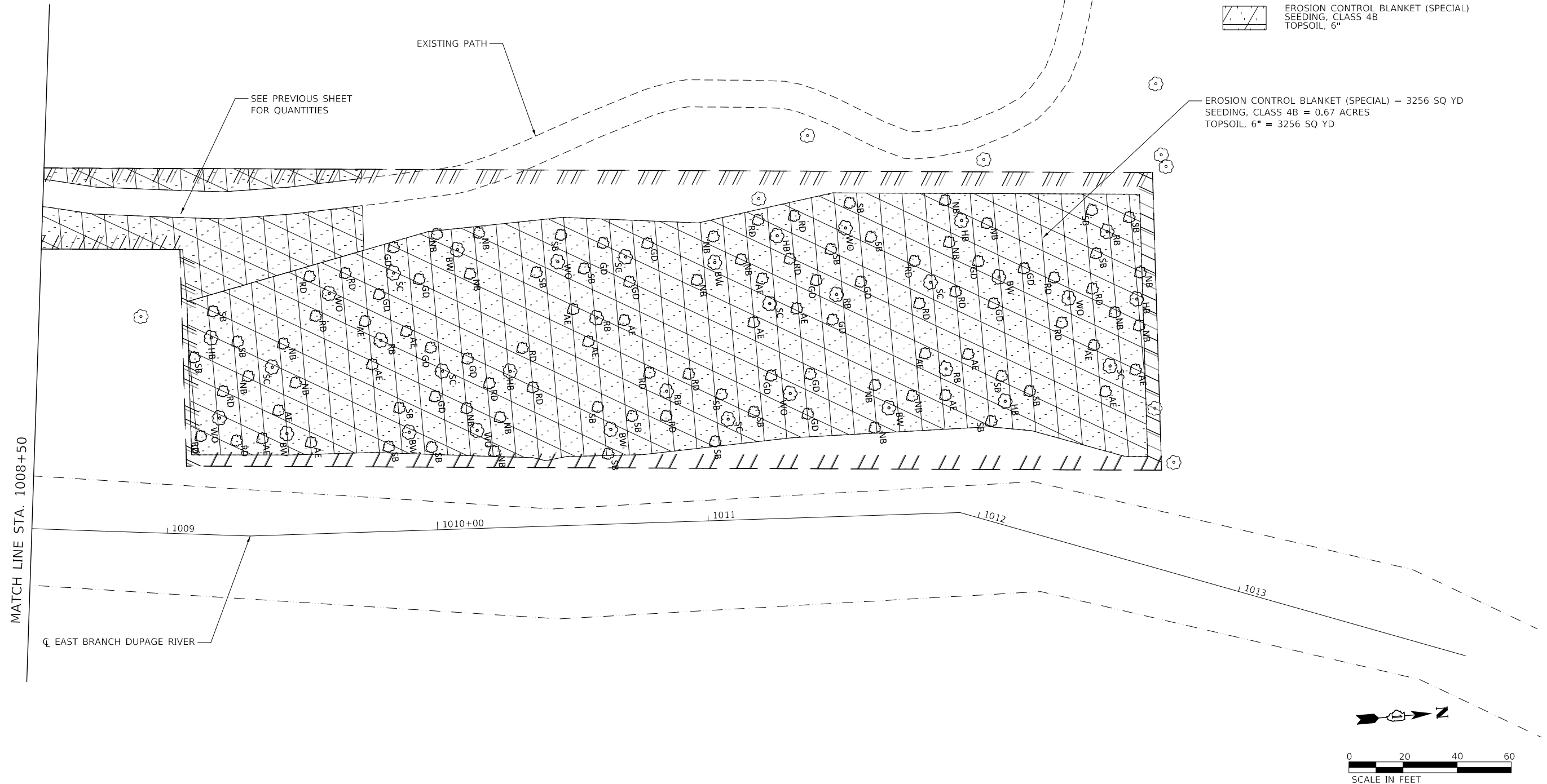

MODEL: 4400BELNAMES
FILE: NAME: 71902-01-14-dupage_05.dgn



DESIGNED -	D.M.S.	REVISED -	
DRAWN -	D.M.S.	REVISED -	
CHECKED -	J.R.S.	REVISED -	
DATE -	3/11/2024	REVISED -	

**STATE OF ILLINOIS
DEPARTMENT OF TRANSPORTATION**

**LANDSCAPE PLAN
NORTH COMPENSATORY STORAGE**

SCALE: 1" = 20' SHEET 6 OF 6 SHEETS STA. 1008+50 TO STA. 1013+00

F.A.U. RTE.	SECTION	COUNTY	TOTAL SHEETS	SHEET NO.
1479	14-00124-04-BR	DUPAGE	208	115
CONTRACT NO. 61114				
ILLINOIS FED. AID PROJECT				

BAR	SIZE	A	B
d(E)	#6	1'-0"	3'-10"
d ₁ (E)	#4	8"	3'-10"

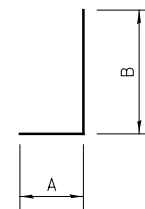

BARS d(E) & d₁(E)

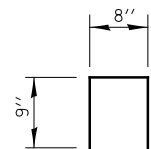

BAR d₂(E)

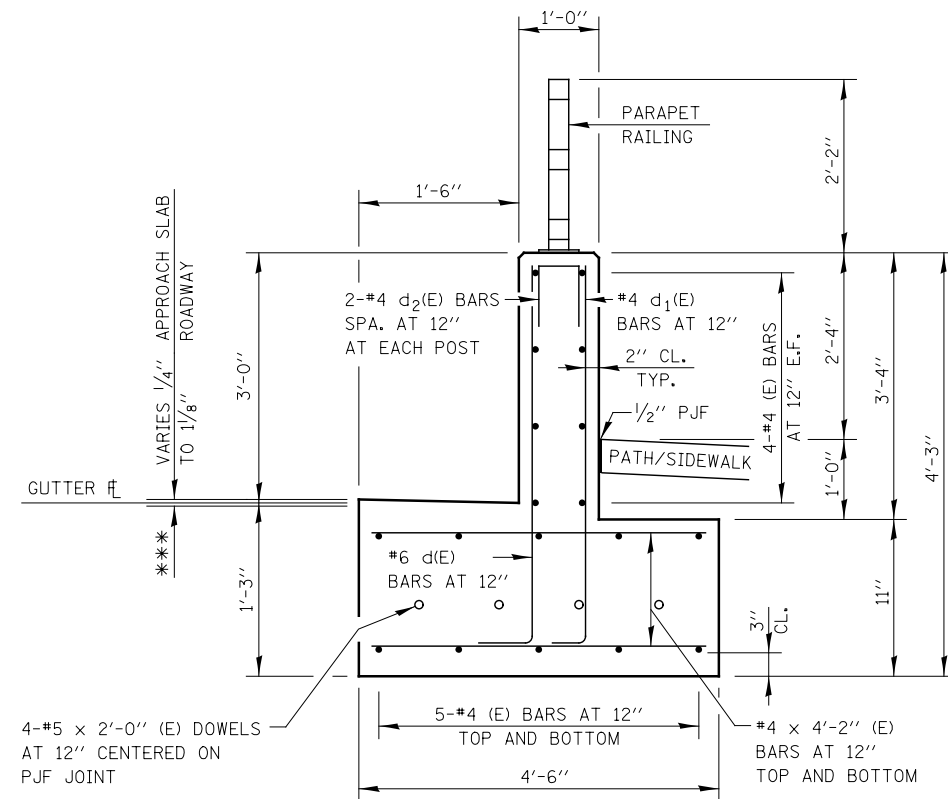

***TRANSITION PAVEMENT AND GUTTER CROSS SLOPE
 EASTBOUND, EAST AND WEST OF BRIDGE - 2.0% IN (APPROACH SLAB) TO 6.0% IN (ROADWAY)
 WESTBOUND, WEST OF BRIDGE - 1.5% OUT (APPROACH SLAB) TO 6.0% IN (ROADWAY)
 WESTBOUND, EAST OF BRIDGE - 1.5% OUT (APPROACH SLAB) TO 2.0% OUT (ROADWAY)

CROSS-SECTION
 CONCRETE BARRIER WALL (SPECIAL)

NOTES

1. ALL STEEL RAIL ELEMENTS SHALL BE GALVANIZED ACCORDING TO ARTICLE 509.05 OF THE STANDARD SPECIFICATIONS.
2. REINFORCEMENT BARS DESIGNATED (E) SHALL BE EPOXY COATED.
3. ALL EXPOSED CONCRETE EDGES SHALL HAVE A 3/4" X 45° CHAMFER, EXCEPT WHERE SHOWN OTHERWISE. CHAMFER ON VERTICAL EDGES SHALL BE CONTINUED A MINIMUM OF ONE FOOT BELOW FINISHED GROUND LEVEL.
4. REINFORCEMENT BARS SHALL BE INCLUDED IN THE COST OF CONCRETE BARRIER WALL (SPECIAL).
5. PARAPET RAILING SHALL BE PAID FOR AS PARAPET RAILING.
6. AGGREGATE SUBGRADE IMPROVEMENT 16" SHALL BE PLACED UNDERNEATH WALL FOOTING AND SHALL BE PAID FOR SEPARATELY.
7. POLYUREA JOINT FILLER (P.J.F.) TO BE PROVIDED BETWEEN CONCRETE BARRIER WALL (SPECIAL) AND THE BRIDGE PARAPET WALL.

LEGEND

E.F. EACH FACE
 P.J.F. PREFORMED JOINT FILLER

MODEL: 4400BELNAMES
 FILE NAME: 719402-14-Cont-BarrierWallSpecial_01.dgn



DESIGNED -	D.M.S.	REVISED -	
DRAWN -	D.M.S.	REVISED -	
CHECKED -	J.R.S.	REVISED -	
DATE -	2/8/2024	REVISED -	

**STATE OF ILLINOIS
 DEPARTMENT OF TRANSPORTATION**

**ROADWAY DETAIL
 CONCRETE BARRIER WALL (SPECIAL)**

SCALE: NONE SHEET 1 OF 2 SHEETS STA. TO STA.

F.A.U. RTE.	SECTION	COUNTY	TOTAL SHEETS	SHEET NO.
1479	14-00124-04-BR	DUPAGE	208	116
				CONTRACT NO. 61114
		ILLINOIS	FED. AID PROJECT	

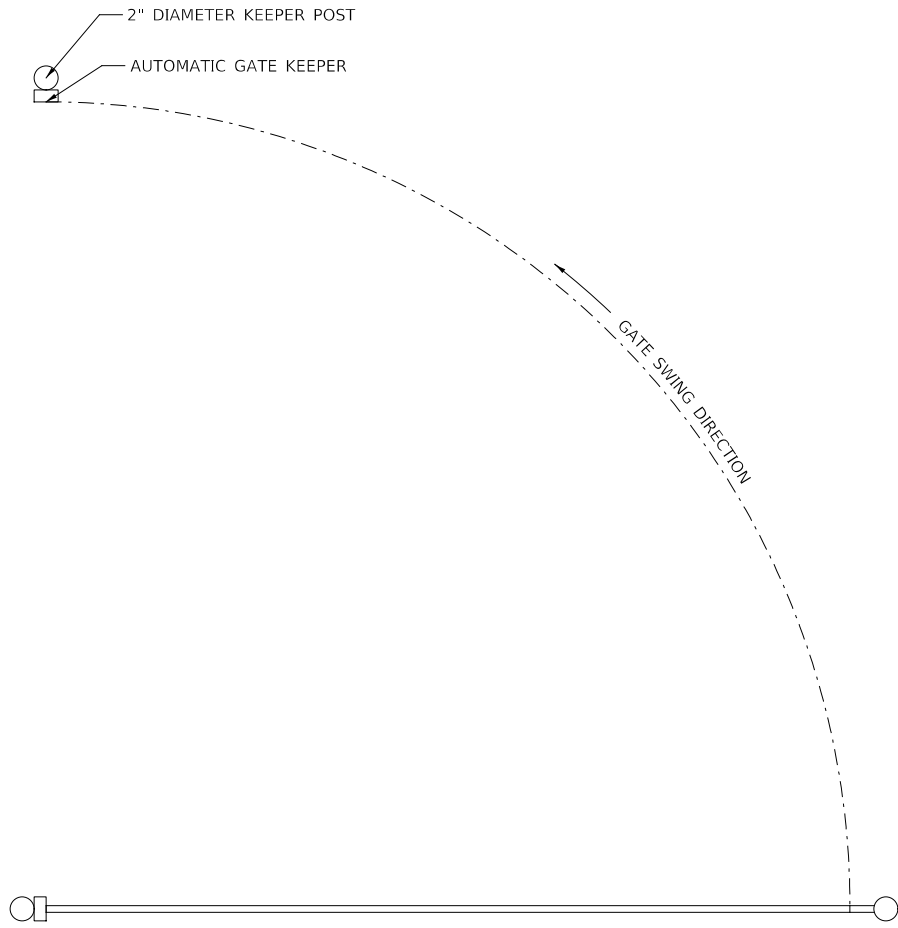
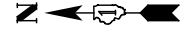

**AUTOMATIC GATE KEEPER
CONCEPT**

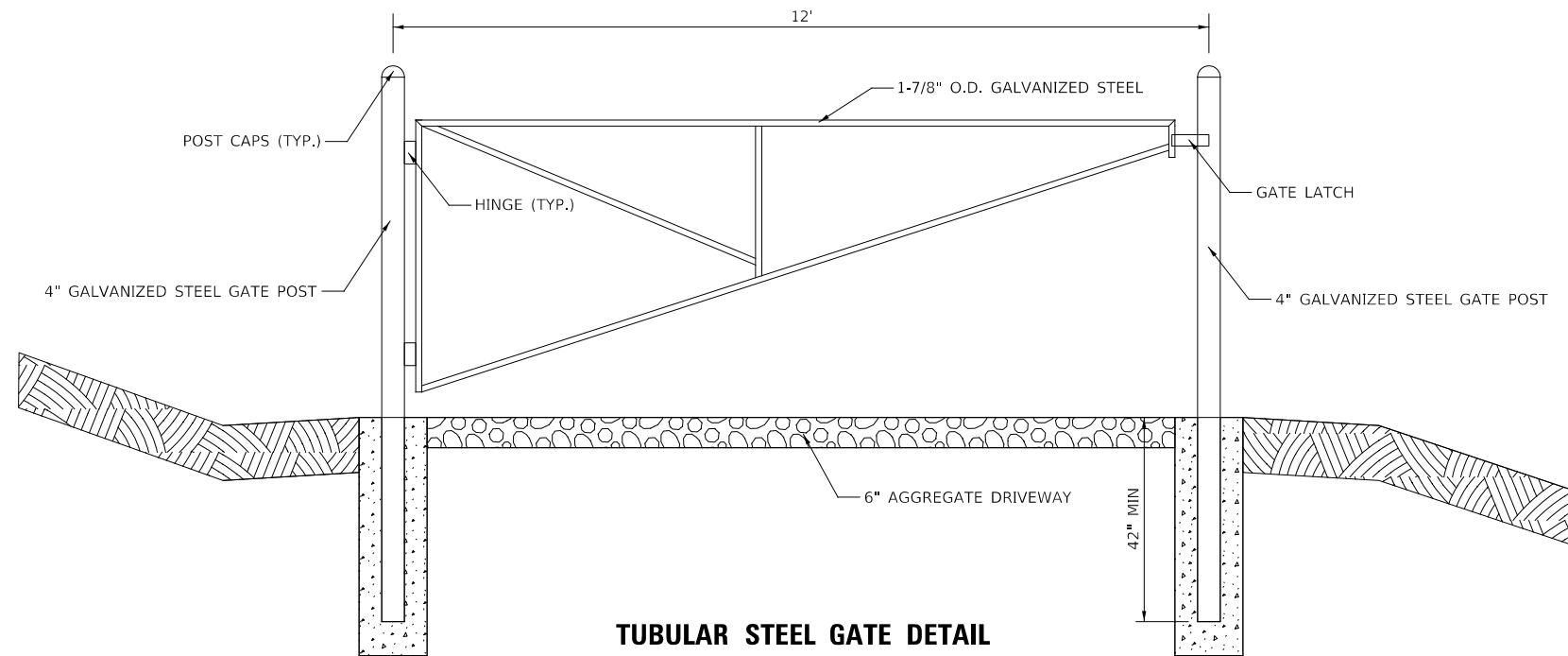

TUBULAR STEEL GATE DETAIL

MODEL: 4400BELNAMES
FILE: NAME: 719402-14-Cont-11a-Tubular-Steel-Gate.dgn



DESIGNED -	D.M.S.	REVISED -	
DRAWN -	D.M.S.	REVISED -	
CHECKED -	J.R.S.	REVISED -	
DATE -	2/8/2024	REVISED -	

**STATE OF ILLINOIS
DEPARTMENT OF TRANSPORTATION**

**ROADWAY DETAIL
TUBULAR STEEL GATE**

SCALE: NONE SHEET 2 OF 2 SHEETS STA. TO STA.

F.A.U. RTE.	SECTION	COUNTY	TOTAL SHEETS	SHEET NO.
1479	14-00124-04-BR	DUPAGE	208	117
CONTRACT NO. 61114				
ILLINOIS FED. AID PROJECT				

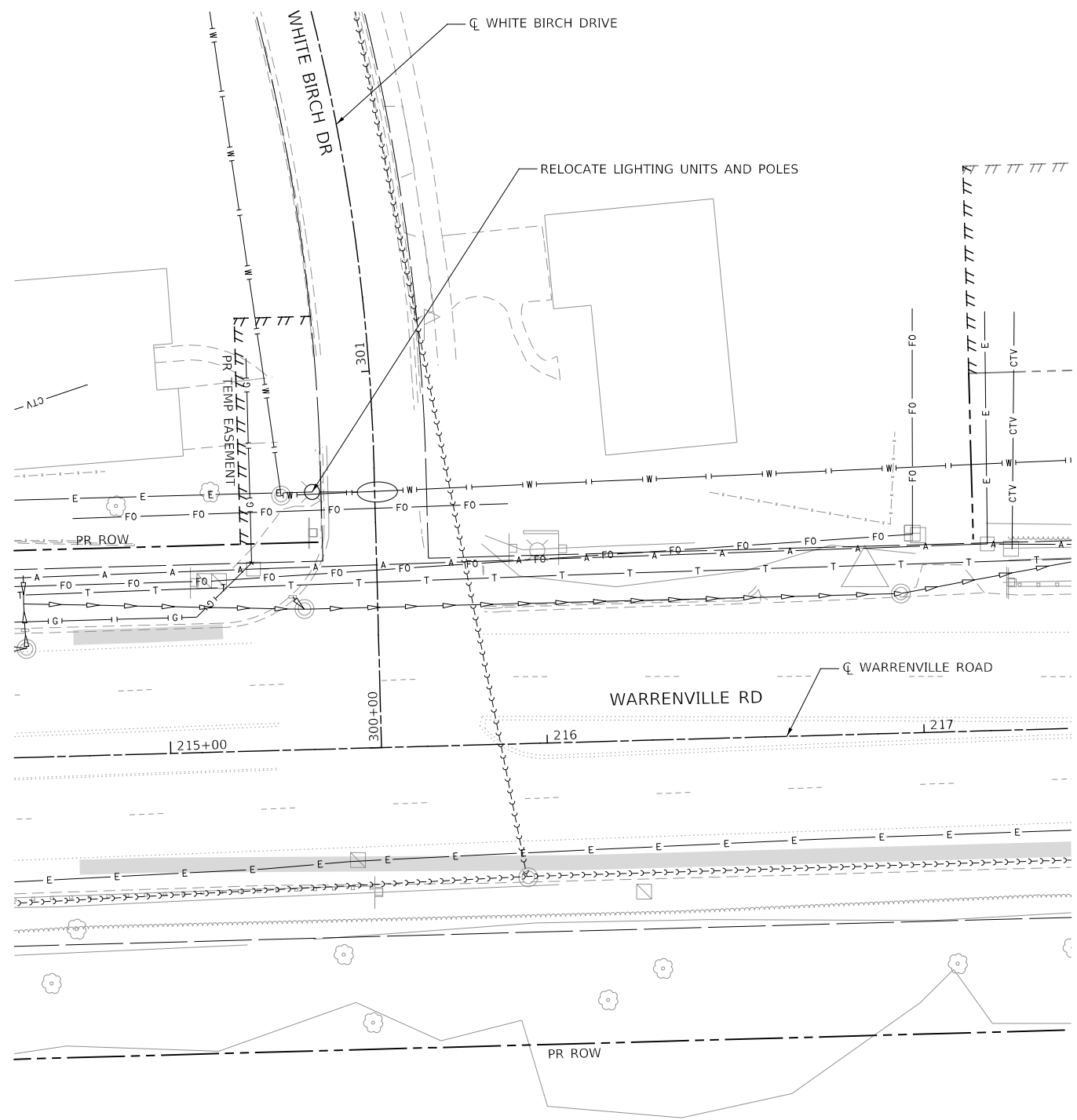

EXISTING LIGHTING

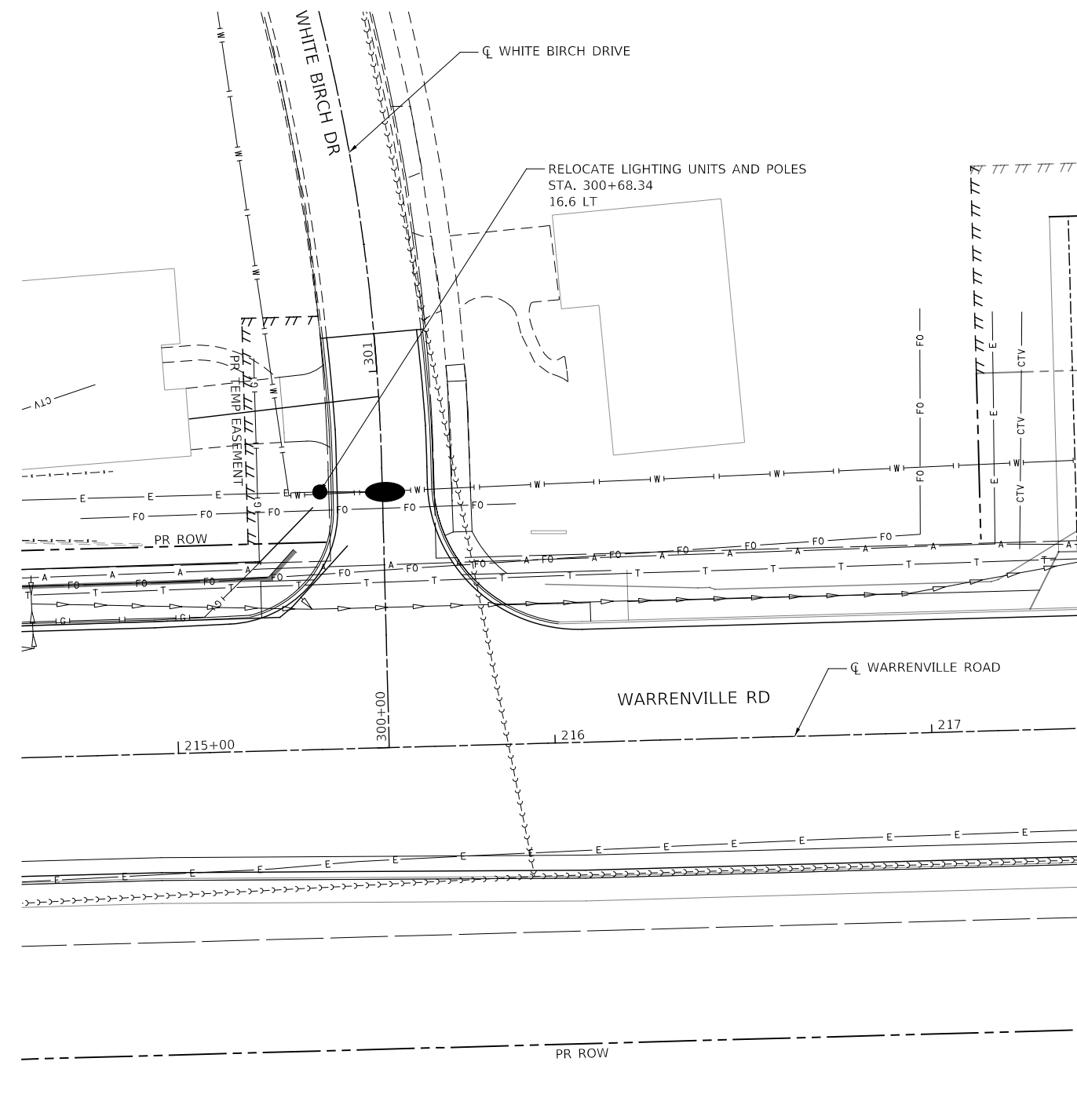
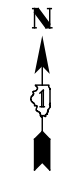

PROPOSED LIGHTING

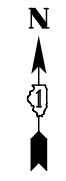

MODEL: 4400BELNAMES
 FILE: 14-00124-04-14-lighting-01_Warrenville.dwg



DESIGNED -	D.M.S.	REVISED -	
DRAWN -	D.M.S.	REVISED -	
CHECKED -	J.R.S.	REVISED -	
DATE -	2/20/2024	REVISED -	

**STATE OF ILLINOIS
DEPARTMENT OF TRANSPORTATION**

**LIGHTING PLAN
WARRENVILLE ROAD**

SCALE: 1" = 20' SHEET 1 OF 1 SHEETS STA. 214+75 TO STA. 217+50

F.A.U. RTE.	SECTION	COUNTY	TOTAL SHEETS	SHEET NO.
1479	14-00124-04-BR	DUPAGE	208	118
CONTRACT NO. 61114				

ILLINOIS FED. AID PROJECT

Bench Mark: Bronze disc on top of curb at northeast corner of Warrenville Road Bridge over EB - DuPage River; Elev. - 670.86

Existing Structure: The existing 64' wide by 55'-6" long bridge structure number 022-3003 was originally constructed in 1946, and was reconstructed in 1982. The original abutments from 1946 in the center 38' of the bridge remain in service. In 1982 the superstructure was replaced with adjacent 27"x48" Precast Prestressed Concrete box beams. The abutments are cast-in-place reinforced concrete full-height closed abutments with wing walls at the corners.

Staging: During construction one lane of traffic in each direction will be maintained on the eastbound lanes for Stage I, and will be moved to the new westbound lanes for Stage II construction. The raised median will be constructed in Stage III with traffic maintained in the outer lanes.

No Salvage

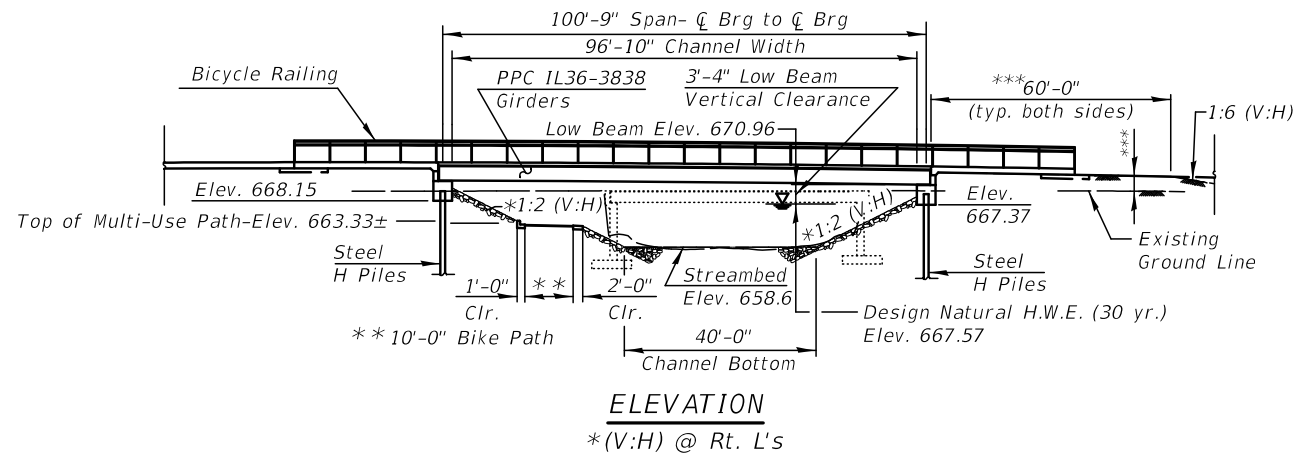

*** Refer to General Note on S-02 regarding minimum embankment construction prior to construction of abutments and approaches.

STATION 220+29.80
BUILT 20XX BY
DUPAGE COUNTY
F.A.U. RT. 1479 SEC. 14-00124-04-BR
LOADING HL93
STRUCTURE NO. 022-3055

NAME PLATE

Locate Name Plate at Southwest Corner of Bridge - See Std. 515001

DESIGN STRESSES
FIELD UNITS

- $f_c = 3,500$ psi
- $f'_c = 4,000$ psi (superstructure concrete)
- $f_y = 60,000$ psi (reinforcement)
- $f_y = 50,000$ psi (AASHTO M270 Gr. 50)

PRECAST PRESTRESSED UNITS

- $f'_c = 8,500$ psi
- $f'_ci = 7,000$ psi
- $f_{pu} = 270,000$ psi (0.6" \emptyset) low lax strands
- $f_{pbt} = 202,500$ psi (0.6" \emptyset) low lax strands

DESIGN SPECIFICATIONS

2020 AASHTO LRFD Bridge Design Specifications, 9th Edition

LOADING HL-93

Allow 50#/sq. ft. for future wearing surface.

SEISMIC DATA

Seismic Performance Zone (SPZ) = 1
Design Spectral Acceleration at 1.0 sec. (S_{D1}) = 0.089g
Design Spectral Acceleration at 0.2 sec. (S_{D5}) = 0.160g
Soil Site Class = D

WATERWAY INFORMATION

Existing Low Grade Elev. 669.7 @ Sta. 218+42
Drainage Area = 37.7 Sq. Mi. Proposed Low Grade Elev. 669.9 @ Sta. 224+40

Flood	Freq. Yr.	Q C.F.S.	Opening Sq. Ft.		Nat. H.W.E.		Head - Ft.		Headwater El	
			Exist.	Prop.	Exist.	Prop.	Exist.	Prop.	Exist.	Prop.
Design	10	1525	333	413	665.7	665.7	0.0	0.0	665.7	665.7
OVT Existing	30	2215	416	579	667.2	667.2	0.7	0.5	667.9	667.7
Base	50	2790	416	654	668.4	668.4	1.36	0.7	669.9	669.4
Max. Calc./OVT (P)	100	3502	416	717	669.1	669.1	1.6	1.0	670.7	670.1
	500	5760	416	891	670.5	670.5	1.6	1.7	672.1	672.2

10-Year Velocity through Existing Bridge = 4.4 fps
10-Year Velocity through Proposed Bridge = 3.2 fps
2-Year proposed flow = 780.8 cfs

DESIGN SCOUR ELEVATION TABLE

Event / Limit	Design Scour Elevations (ft.)
State	W. Abut. E. Abut. Item 113
Q100	668.15 667.37
Q200	668.15 667.37
Design	668.15 667.37
Check	668.15 667.37

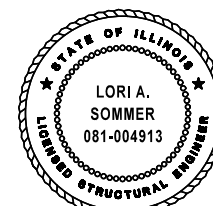
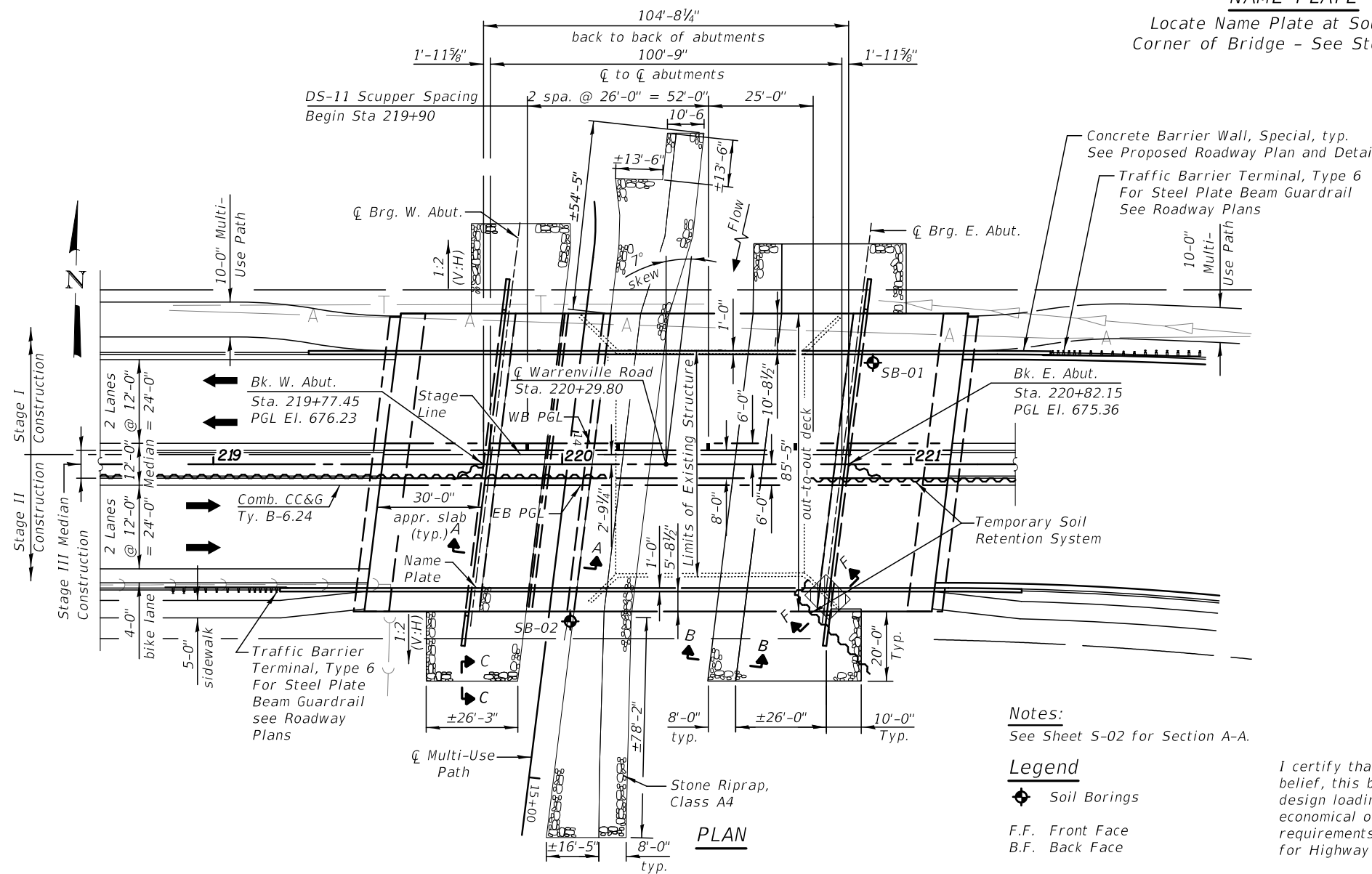

Loria Sommer

Expires 11-30-2024
Date: 12/18/2023
Drawings:
Sheet Nos. S-01 to S-36

Notes:
See Sheet S-02 for Section A-A.

Legend

- \blacklozenge Soil Borings
- F.F. Front Face
- B.F. Back Face

I certify that to the best of knowledge, information and belief, this bridge design is structurally adequate for the design loading shown on the plans. The design is an economical one for the style of structure and complies with requirements of the current AASHTO Standard Specifications for Highway Bridges.

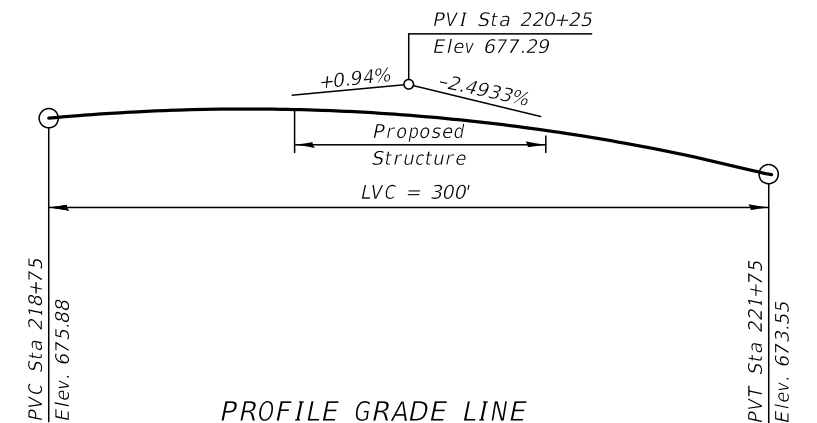

PROFILE GRADE LINE
(Along E.B. & W.B. PGL)

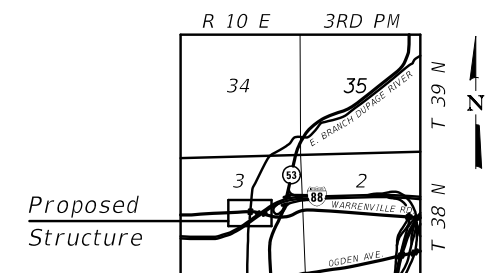

LOCATION SKETCH

PLOT DATE = 2/9/2024

KNIGHT Member of WSP	DESIGNED - FJW	REVISED	STATE OF ILLINOIS DEPARTMENT OF TRANSPORTATION	GENERAL PLAN AND ELEVATION STRUCTURE NUMBER 022-3055	F.A.U. RTE. 1479	SECTION 14-00124-00-BR	COUNTY DUPAGE	TOTAL SHEETS 208	SHEET NO. 119
	CHECKED - LAS	REVISED			CONTRACT NO. 61J14	ILLINOIS FED. AID PROJECT			
SCALE - NONE	DRAWN - DJC	REVISED	SHEET S-01 OF 36 SHEETS						
DATE - 2/9/2024	CHECKED - LAS	REVISED							

GENERAL NOTES

Fasteners shall be ASTM A325 Type 1, mechanically galvanized bolts, 3/4 in. dia., holes 1 1/16 in. dia., unless otherwise noted.

Reinforcement bars designated (E) shall be epoxy coated.

The embankment configuration shown shall be the minimum that must be placed and compacted prior to construction of the abutments and bridge approach slabs. See sheet S-01 for details.

All exposed concrete edges shall have a 3/4" x 45° chamfer, except where shown otherwise. Chamfer on vertical edges shall be continued a minimum of one foot below finished ground level.

Reinforcement bar bending details shall be in accordance with the latest "Manual of Standard Practice for Detailing Reinforced Concrete Structures", ACI 315.

Reinforcement bar bending dimensions are out to out.

Cover from the face of concrete to face of reinforcement bars shall be 3" for surfaces formed against earth and 2" for all other surfaces unless otherwise shown.

Contractor shall not scale dimensions from the Contract Plans for construction purposes. Scales shown are for information only.

No construction joints except those shown on the plans will be allowed unless approved by the Engineer.

It shall be the Contractor's responsibility to verify the location of all utilities prior to starting construction. Contact J.U.L.I.E., 800-892-0123.

Current Rating on File for Existing Structure:

Inventory: HS11

Operating: HS20

Live Load Restrictions: Yes (Single Unit Vehicle: 17 ton), (Combination Type 3S-1: 20 ton), (Combination Type 3S-2: 25 ton)

Inventory and Operating Ratings and Live Load Restrictions are provided for information only. Inventory and Operating Ratings are based on HS loading and configuration. Live Load Restrictions are based on Illinois legal loads and configurations. The Ratings and Live Load Restrictions are not necessarily representative and capacities to support the Contractor's equipment.

The fabricator, the Contractor and the beam transportation company shall provide adequate bracing and support for the PPC beams during handling, transporting, storing and erecting to ensure the safety of the personnel associated with the construction of the project.

After the beams are set, all elevations for determining fillet heights shall be taken at one time for all beams within that stage.

The soil boring logs represent point information. Presentation of this information in no way implies that subsurface conditions are the same at locations other than the exact location of the boring.

Layout of the slope protection system may be varied to suit ground conditions in the field as directed by the Engineer.

Slipforming of the parapet walls is not allowed.

All in-stream work, including but not limited to abutment removal, proposed structure work, slope grading and permanent slope stabilization shall be in accordance with the Erosion Control in-stream Sequence of Work and Cofferdam Plan.

ComEd overhead lines will be relocated. Contractor is responsible for coordination with ComEd at no additional cost to the Owner.

INDEX OF SHEETS

S-01	General Plan and Elevation
S-02	General Notes and Total Bill Of Material
S-03	Substructure Layout
S-04	Temporary Soil Retention System Plan
S-05	Temporary Soil Retention System Details
S-06	Stage Construction
S-07	Temporary Concrete Barrier for Stage Construction
S-08	Top of Slab Elevations - Location Plan
S-09	Top of Slab Elevations
S-10	Top of Slab Elevations
S-11	Top of Slab Elevations
S-12	Top of West Approach Slab Elevations
S-13	Top of East Approach Slab Elevations
S-14	Deck Plan and Cross Section
S-15	Shared Use Path and Parapet Details
S-16	Sidewalk and Parapet Details
S-17	Diaphragm Details
S-18	Deck Miscellaneous Details
S-19	Bridge Approach Slab Plan
S-20	Bridge Approach Slab Details
S-21	Drainage Scupper, DS-11
S-22	Framing Plan and Permanent Bracing Details
S-23	IL36 Beam
S-24	IL36 Beam Details
S-25	West Abutment
S-26	West Abutment Details
S-27	East Abutment
S-28	East Abutment Details
S-29	Bicycle Railing
S-30	HP Pile Details
S-31	Bar Splicer Assembly And Mechanical Splicer Details
S-32	Existing East Abutment Removal Details
S-33	Existing West Abutment Removal Details
S-34	Existing Abutment Removal Details
S-35	Soil Boring Logs
S-36	Soi Boring Logs

TOTAL BILL OF MATERIAL

ITEM	UNIT	SUPER	SUB	TOTAL
Stone Riprap, Class A4	Sq. Yd.	-	1354	1354
Filter Fabric	Sq. Yd.	-	1187	1187
Removal of Existing Structures	Each	-	1	1
Structure Excavation	Cu. Yd.	-	83	83
Concrete Structures	Cu. Yd.	-	167.3	167.3
Floor Drain	Each	4	-	4
Concrete Superstructure	Cu. Yd.	721.9	-	721.9
Bridge Deck Grooving	Sq. Yd.	995	-	995
Protective Coat	Sq. Yd.	1752	-	1752
Concrete Superstructure (Approach Slab)	Cu. Yd.	237.4	-	237.4
Furnishing And Erecting Precast Prestressed Concrete Beams, IL36	Foot	1530	-	1530
Reinforcement Bars, Epoxy Coated	Pound	161470	16920	178390
Bar Splicers	Each	514	100	614
Bicycle Railing	Foot	326	-	326
Parapet Railing	Foot	326	-	326
Furnishing Steel Piles HP12X63	Foot	-	1106	1106
Driving Piles	Foot	-	1106	1106
Test Pile Steel HP12X63	Each	-	2	2
Pile Shoes	Each	-	30	30
Name Plates	Each	1	-	1
Temporary Soil Retention System	Sq. Ft.	-	3277	3277
Granular Backfill For Structures	Cu. Yd.	-	304	304
Geocomposite Wall Drain	Sq. Yd.	-	155	155
Anti-Graffiti Coating	Sq. Ft.	-	995	995
Pipe Underdrains For Structures 4"	Foot	-	224	224
Pile Removal	Each	-	2	2
Drainage Scuppers, DS-11	Each	4	-	4

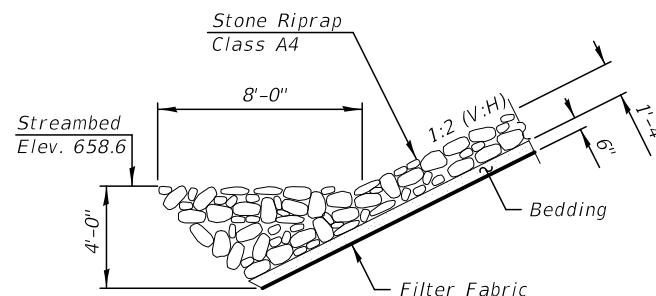
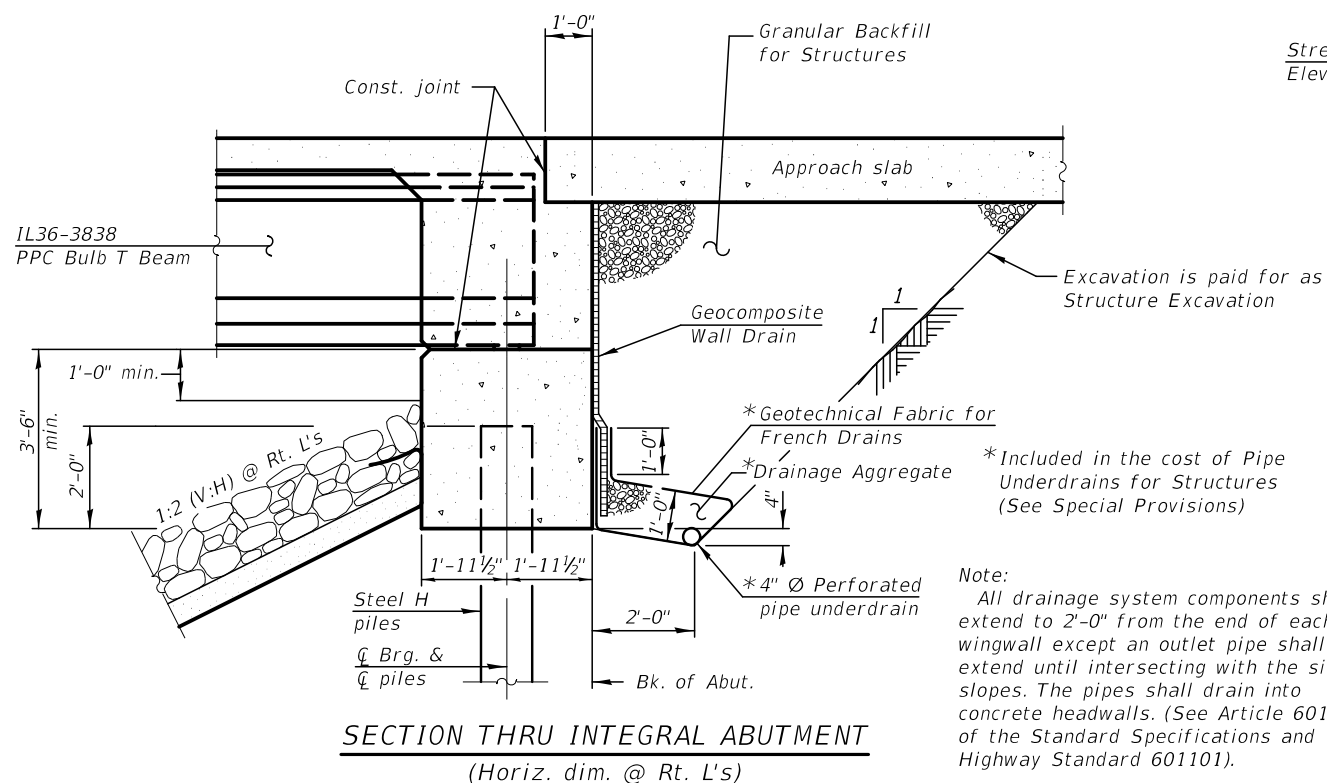

SECTION B-B
Stone Riprap Toe Anchor Detail
For Section C-C see Sheet S-01

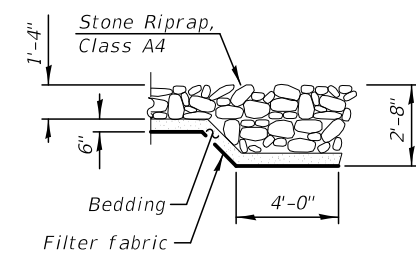

SECTION C-C
Stone Riprap Flank Detail
For Section C-C see Sheet S-01

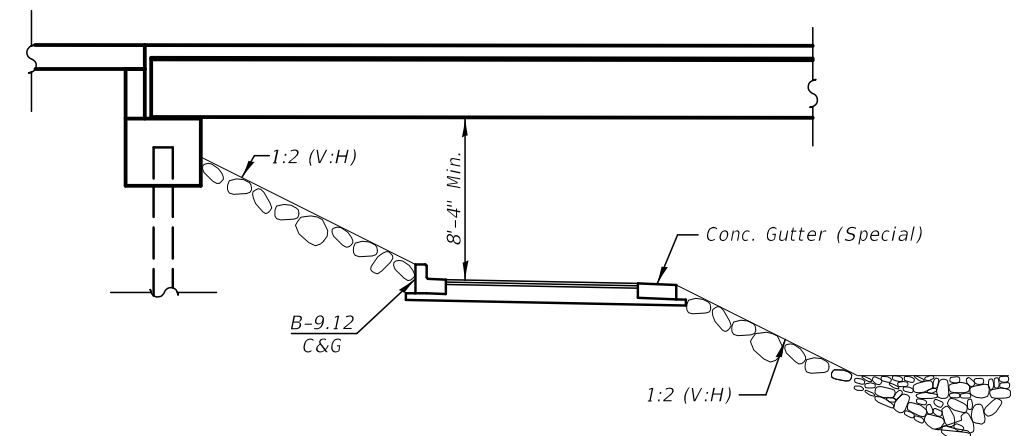

SECTION A-A
For Section A-A see sheet S-01

PLOT DATE = 2/9/2024

KNIGHT Member of WSP	DESIGNED - FJW	REVISED
	CHECKED - LAS	REVISED
	SCALE - NONE	REVISED
	DATE - 2/9/2024	REVISED

**STATE OF ILLINOIS
DEPARTMENT OF TRANSPORTATION**

**GENERAL NOTES AND TOTAL BILL OF MATERIAL
STRUCTURE NUMBER 022-3055**

F.A.U. RTE.	SECTION	COUNTY	TOTAL SHEETS	SHEET NO.
1479	14-00124-00-BR	DUPAGE	208	120
CONTRACT NO. 61J14				

SHEET S-02 OF 36 SHEETS

ILLINOIS FED. AID PROJECT

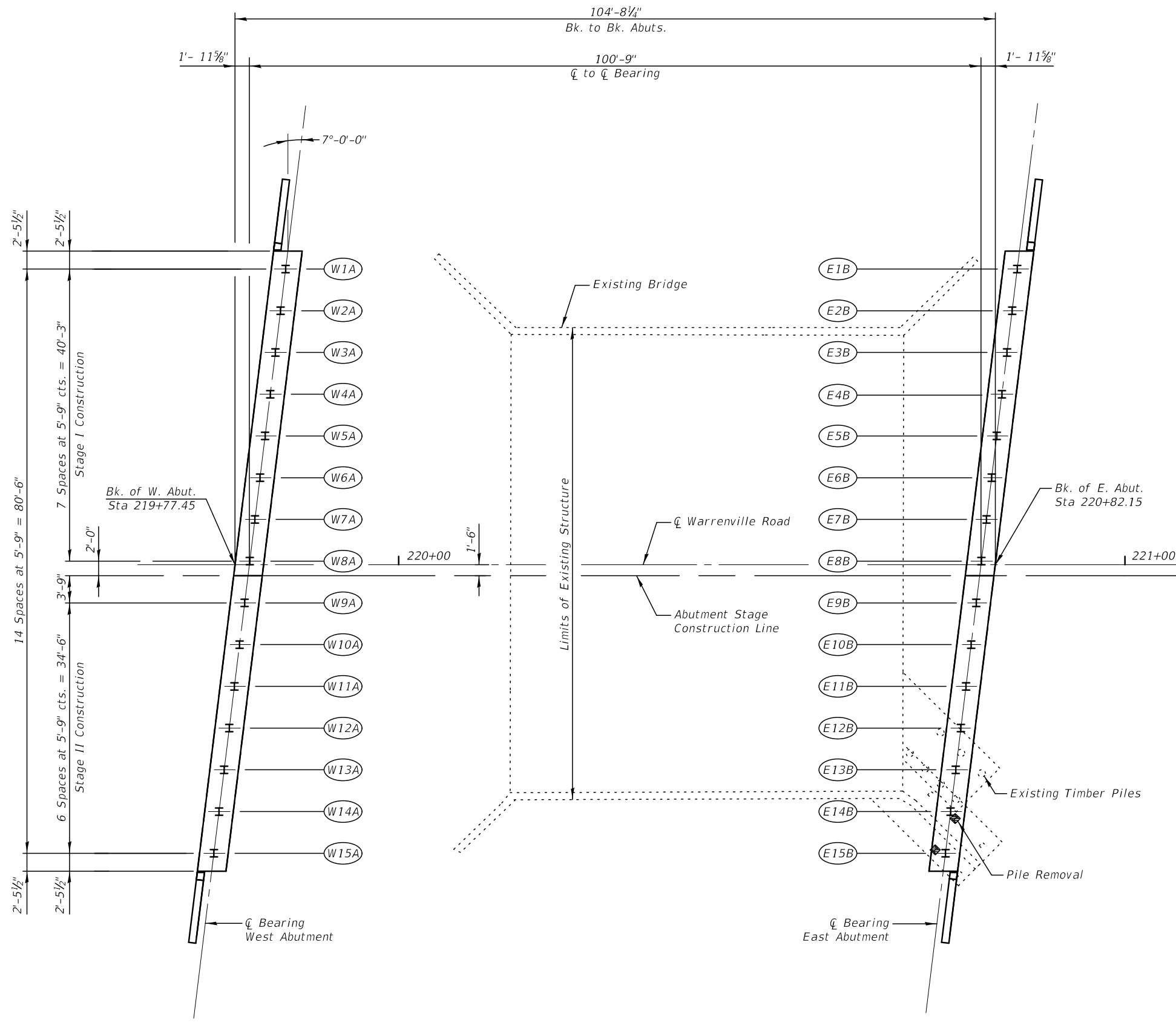

Notes:
 For existing abutment removal details, see Sheets S-32 to S-34.

- LEGEND**
- (W1A) Pile Number
 - ⋮ Existing Pile to Remain
 - ▨ Existing Pile to be Extracted
 - ⊙ Existing Timber Pile

Bill of Material

Item	Unit	Quantity
Pile Removal	Each	2

SUBSTRUCTURE LAYOUT

PLOT DATE = 2/9/2024

KNIGHT
 Member of WSP

DESIGNED - FJW	REVISED
CHECKED - LAS	REVISED
DRAWN - DJC	REVISED
CHECKED - LAS	REVISED

STATE OF ILLINOIS
 DEPARTMENT OF TRANSPORTATION

SUBSTRUCTURE LAYOUT
STRUCTURE NUMBER 022-3055
 SHEET S-03 OF 36 SHEETS

F.A.U. RTE.	SECTION	COUNTY	TOTAL SHEETS	SHEET NO.
1479	14-00124-00-BR	DUPAGE	208	121
CONTRACT NO. 61J14				
ILLINOIS FED. AID PROJECT				

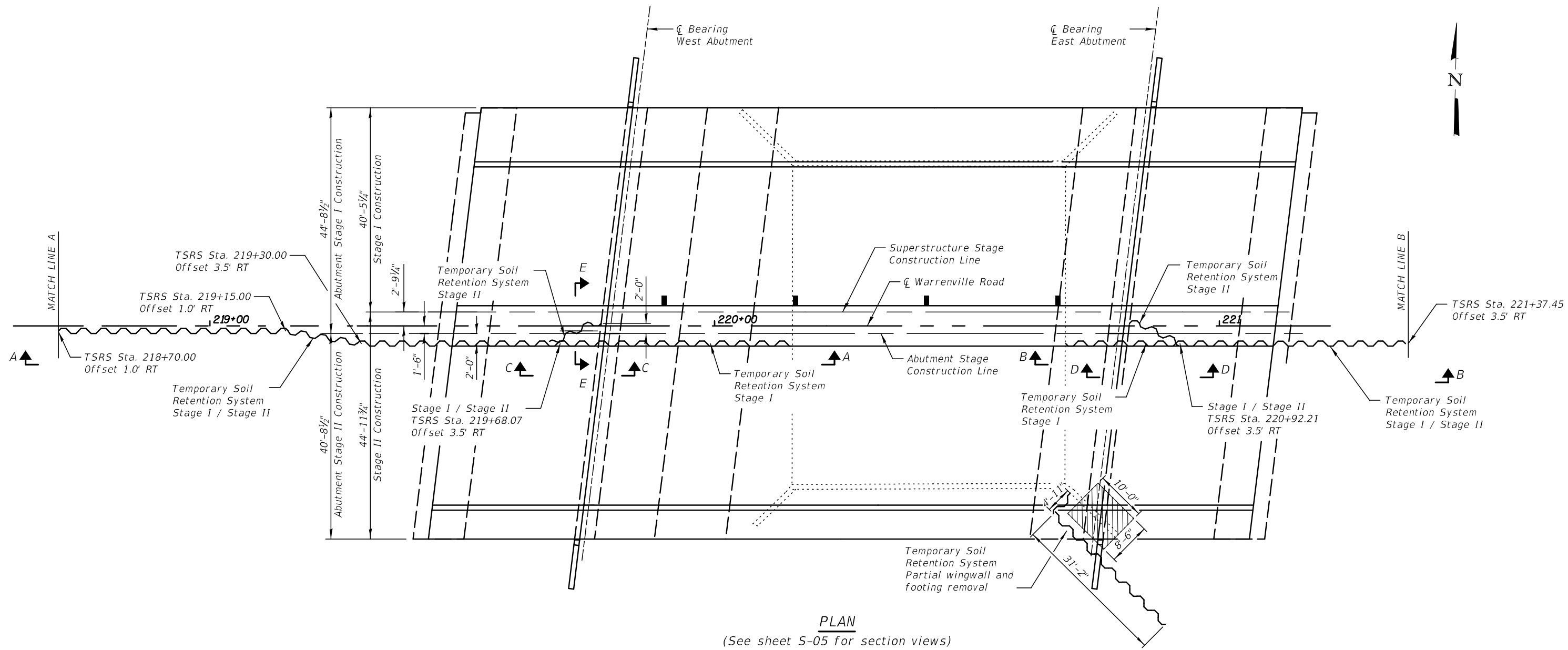

PLAN
(See sheet S-05 for section views)

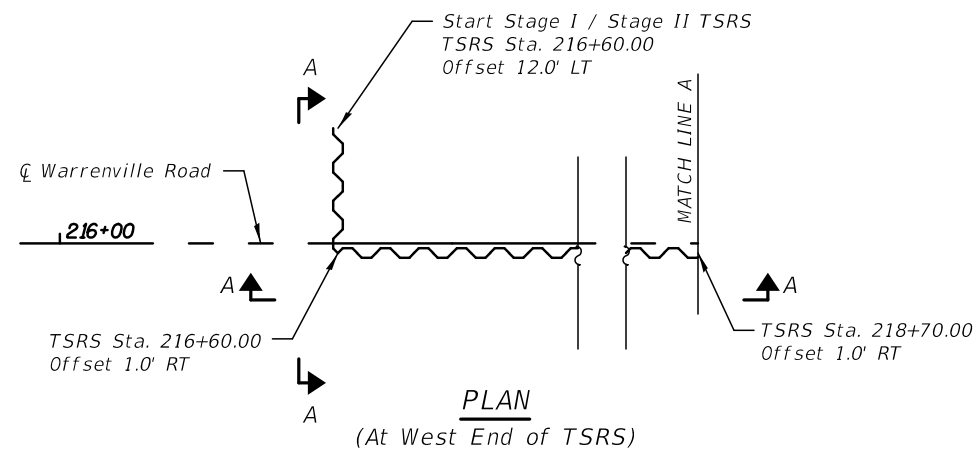

PLAN
(At West End of TSRS)

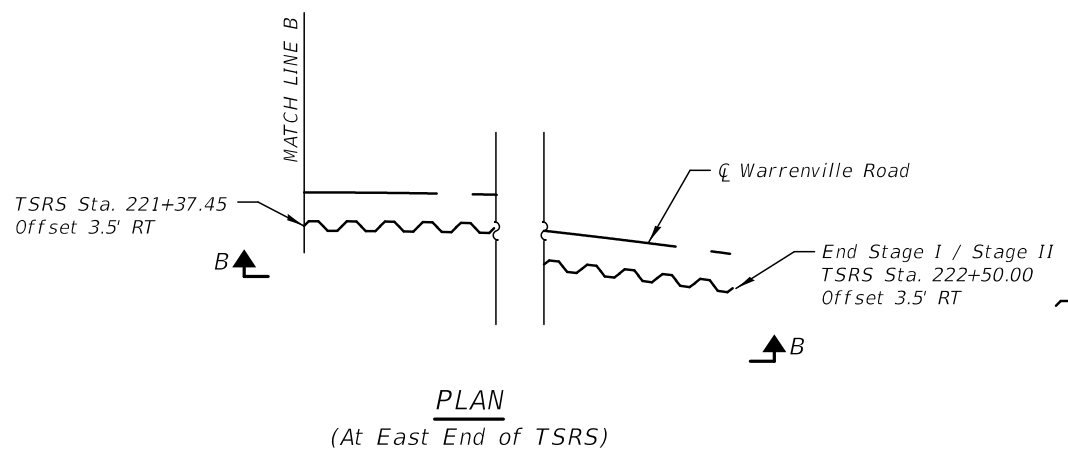

PLAN
(At East End of TSRS)

Bill of Material

Item	Unit	Quantity
Temporary Soil Retention System	Sq. Ft.	3277

Legend

Temporary Soil Retention System

Notes:

A cantilevered sheet piling design does not appear feasible and additional members or other retention systems may be necessary. The Contractor shall submit a temporary soil retention system design including plan details and calculations for review and acceptance by the Engineer.

PLOT DATE = 2/9/2024



DESIGNED - FJW	REVIS
CHECKED - LAS	REVIS
SCALE - NONE	REVIS
DATE - 2/9/2024	REVIS

DESIGNED - FJW	REVIS
CHECKED - LAS	REVIS
DRAWN - DJC	REVIS
CHECKED - LAS	REVIS

STATE OF ILLINOIS
DEPARTMENT OF TRANSPORTATION

TEMPORARY SOIL RETENTION SYSTEM PLAN
STRUCTURE NUMBER 022-3055

SHEET S-04 OF 36 SHEETS

F.A.U. RTE.	SECTION	COUNTY	TOTAL SHEETS	SHEET NO.
1479	14-00124-00-BR	DUPAGE	208	122
CONTRACT NO. 61J14				

ILLINOIS FED. AID PROJECT

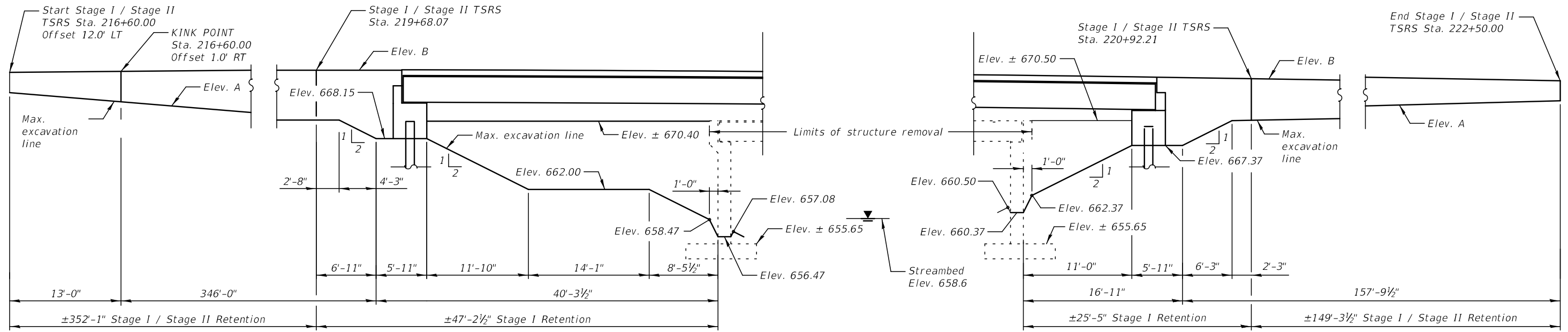

SECTION A-A
West Abutment Stage I

SECTION B-B
East Abutment Stage I

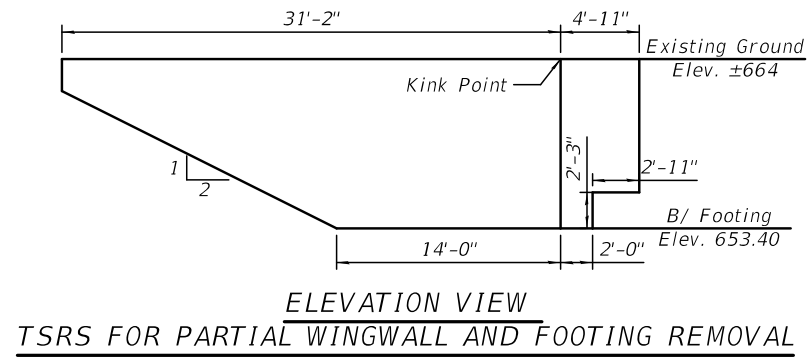

ELEVATION VIEW

TSRS FOR PARTIAL WINGWALL AND FOOTING REMOVAL

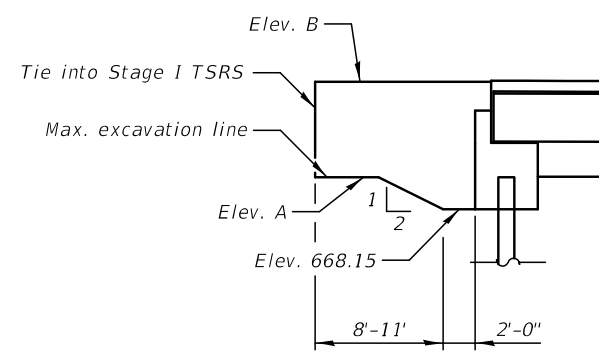

SECTION C-C
West Abutment Stage II

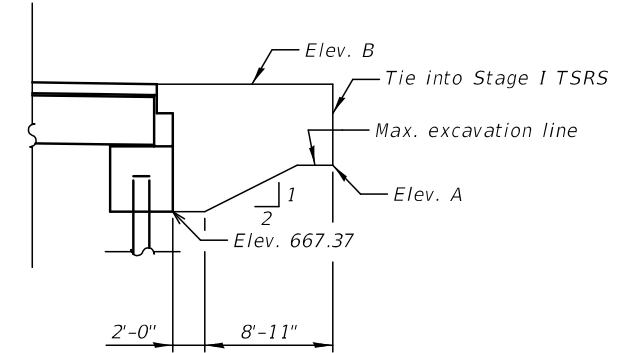

SECTION D-D
East Abutment Stage II

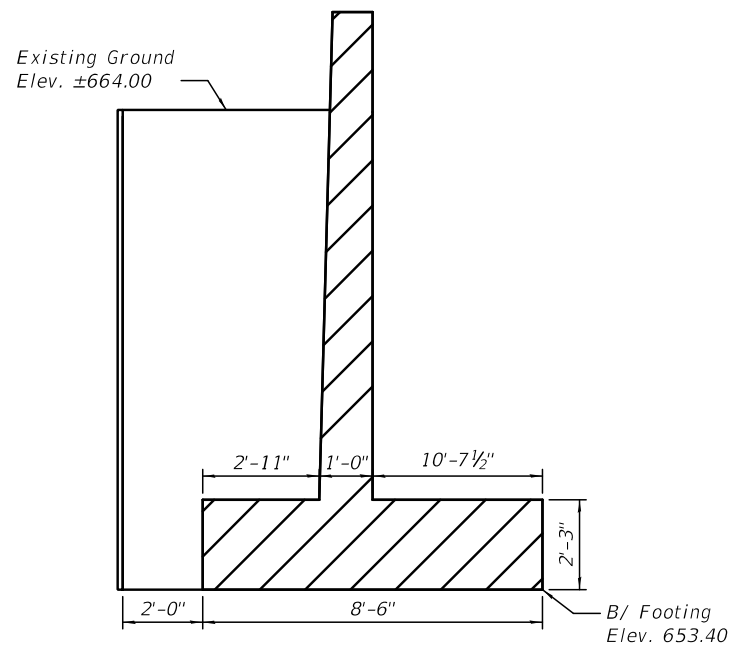

SECTION F-F

Partial wingwall and footing removal

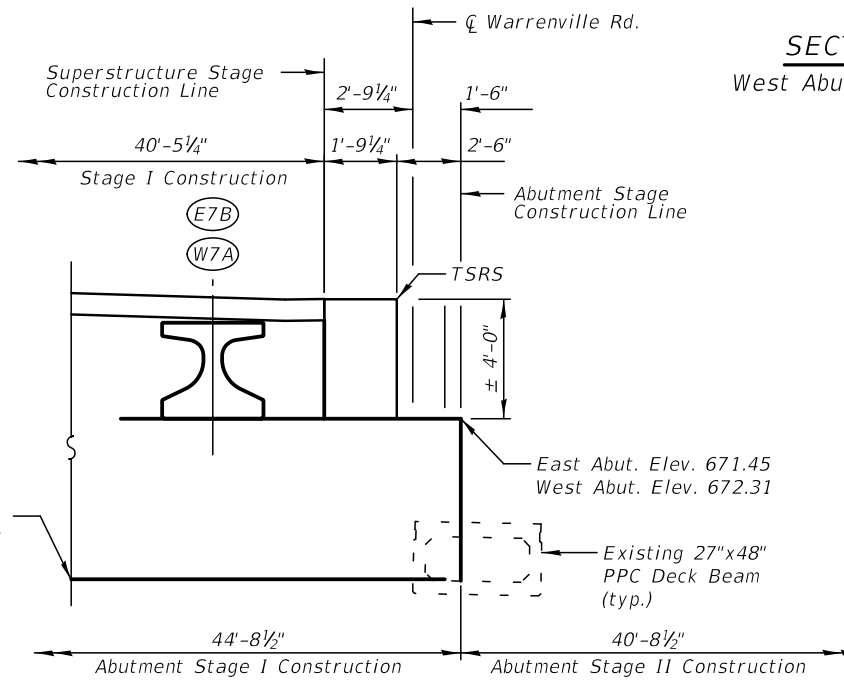

SECTION E-E
Abutment Stage II

GRADE ELEVATIONS

Station	A Existing Grade Elevations	B Proposed Grade Elevations
217+00	670.06	674.39
217+50	669.67	674.70
218+00	669.64	675.17
218+50	669.84	675.64
219+00	670.00	676.08
219+50	670.01	676.26
221+00	670.51	675.10
221+50	670.39	674.14
222+00	670.13	672.93
222+50	669.83	671.70

GRADE ELEVATIONS

Station	Offset	A Existing Grade Elevations	B Proposed Grade Elevations
216+60	1.0' RT	671.11	674.57
216+60	12.0' LT	673.35	674.35

Notes:

The information shown for the TSRS is estimated. It is the contractor's responsibility to provide a design and details for each TSRS complete with calculations and drawings, signed and sealed by an Illinois Licensed Structural Engineer.

PLOT DATE = 2/9/2024



DESIGNED - FJW	REVISION
CHECKED - LAS	REVISION
SCALE - NONE	REVISION
DATE - 2/9/2024	REVISION
DRAWN - DJC	REVISION
CHECKED - LAS	REVISION

DESIGNED - FJW	REVISION
CHECKED - LAS	REVISION
DRAWN - DJC	REVISION
CHECKED - LAS	REVISION

STATE OF ILLINOIS
DEPARTMENT OF TRANSPORTATION

TEMPORARY SOIL RETENTION SYSTEM DETAILS
STRUCTURE NUMBER 022-3055

SHEET S-05 OF 36 SHEETS

F.A.U. RTE.	SECTION	COUNTY	TOTAL SHEETS	SHEET NO.
1479	14-00124-00-BR	DUPAGE	208	123
CONTRACT NO. 61J14				
ILLINOIS FED. AID PROJECT				

Note A:

Upon removal of the north half of the existing Precast Deck Beams, the Contractor shall reinstall the fascia beam nut onto the transverse beam and re-tighten the tie assembly for the remaining beams left in place for Stage I traffic. This work shall be included in the pay item "Removal of Existing Structures."

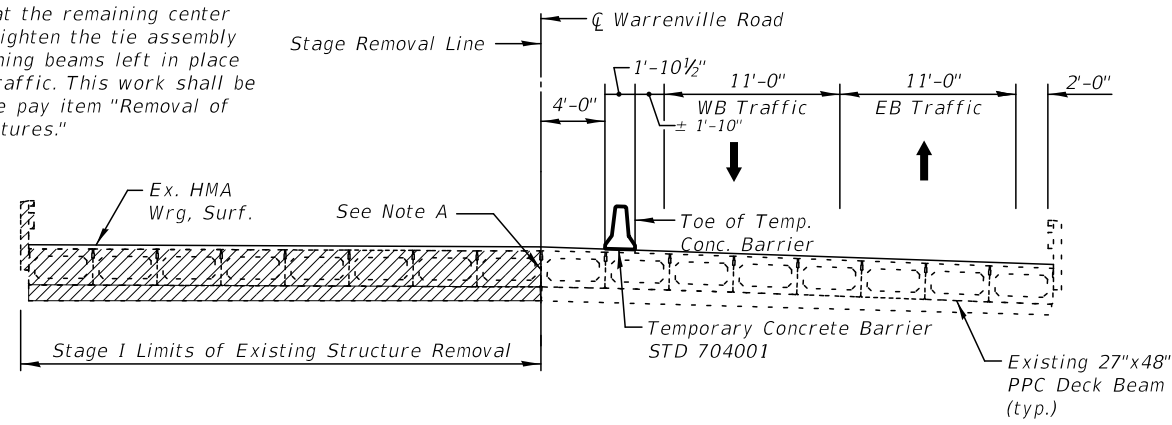

STAGE I REMOVAL
Looking East

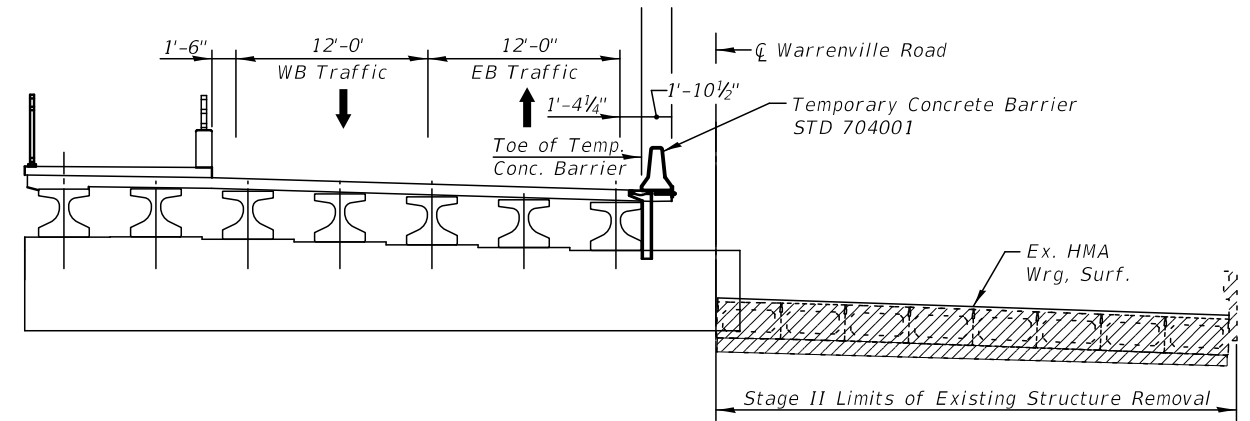

STAGE II REMOVAL
Looking East

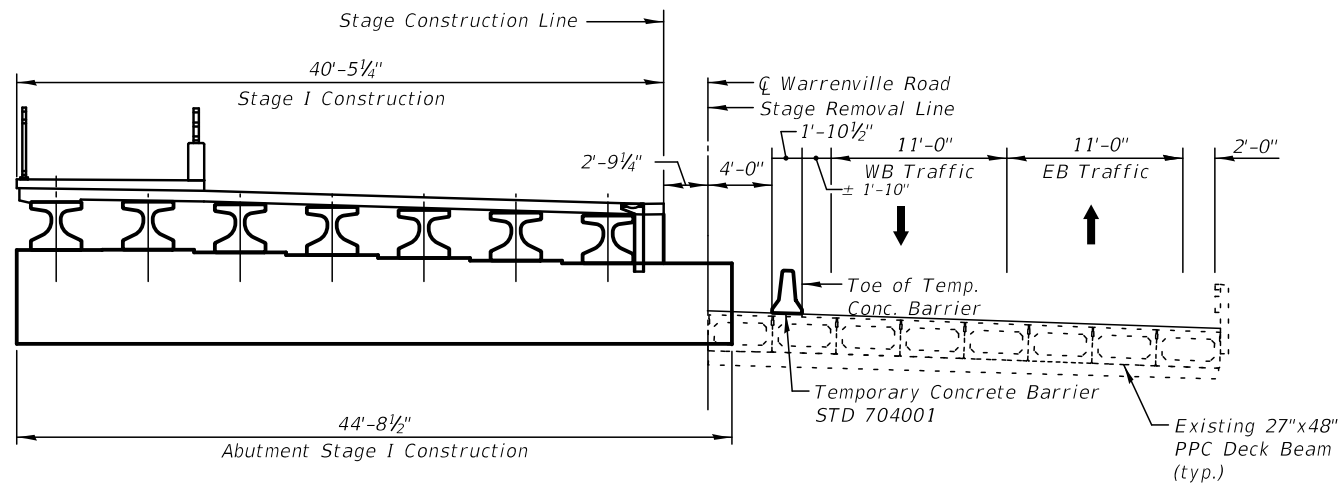

STAGE I CONSTRUCTION
Looking East

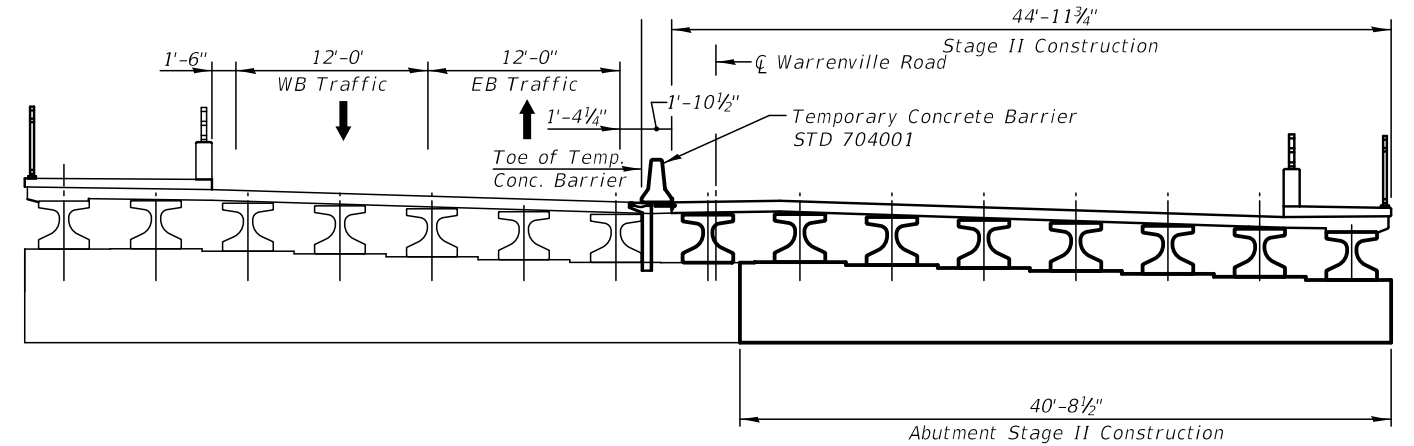

STAGE II CONSTRUCTION
Looking East

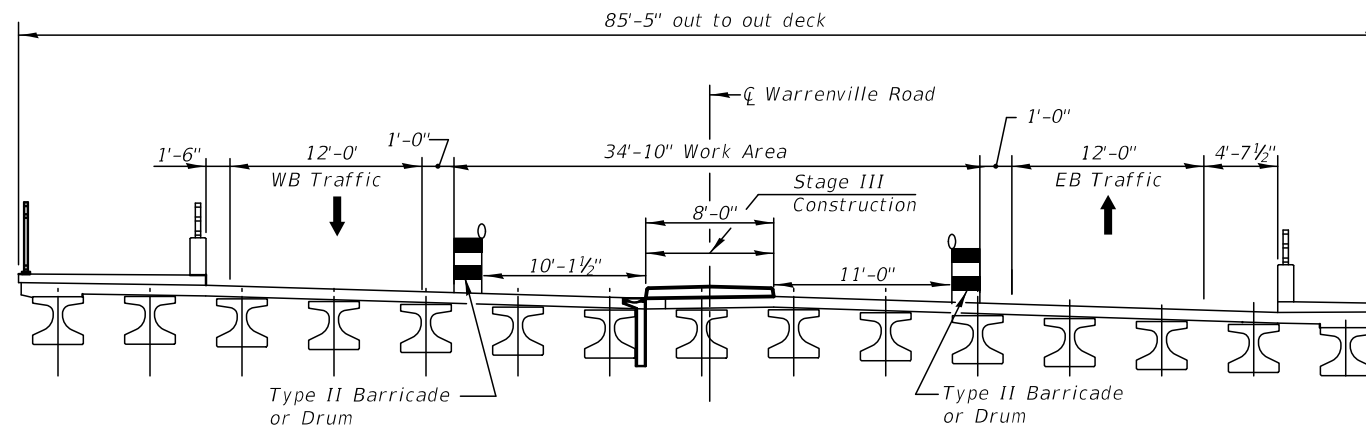

STAGE III - MEDIAN CONSTRUCTION
Looking East

PLOT DATE = 2/9/2024



DESIGNED -	FJW	REVISED	
CHECKED -	LAS	REVISED	
SCALE -	NONE	DRAWN -	DJC
DATE -	2/9/2024	CHECKED -	LAS
		REVISED	

DESIGNED -	FJW	REVISED	
CHECKED -	LAS	REVISED	
DRAWN -	DJC	REVISED	
CHECKED -	LAS	REVISED	

STATE OF ILLINOIS
DEPARTMENT OF TRANSPORTATION

STAGE CONSTRUCTION
STRUCTURE NUMBER 022-3055
SHEET S-06 OF 36 SHEETS

F.A.U. RTE.	SECTION	COUNTY	TOTAL SHEETS	SHEET NO.
1479	14-00124-00-BR	DUPAGE	208	124
CONTRACT NO. 61J14				
ILLINOIS FED. AID PROJECT				

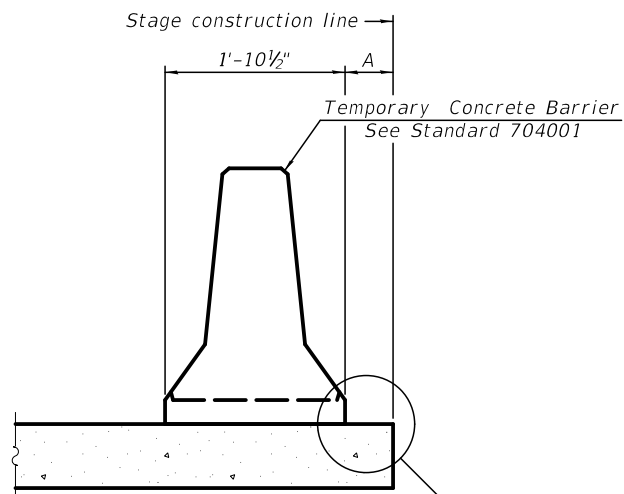

When "A" is 3'-1" or less, the temporary concrete barrier shall be restrained to the new slab according to Detail I, II or III. No restraint is required when "A" is greater than 3'-1".

NEW SLAB OR NEW DECK BEAM

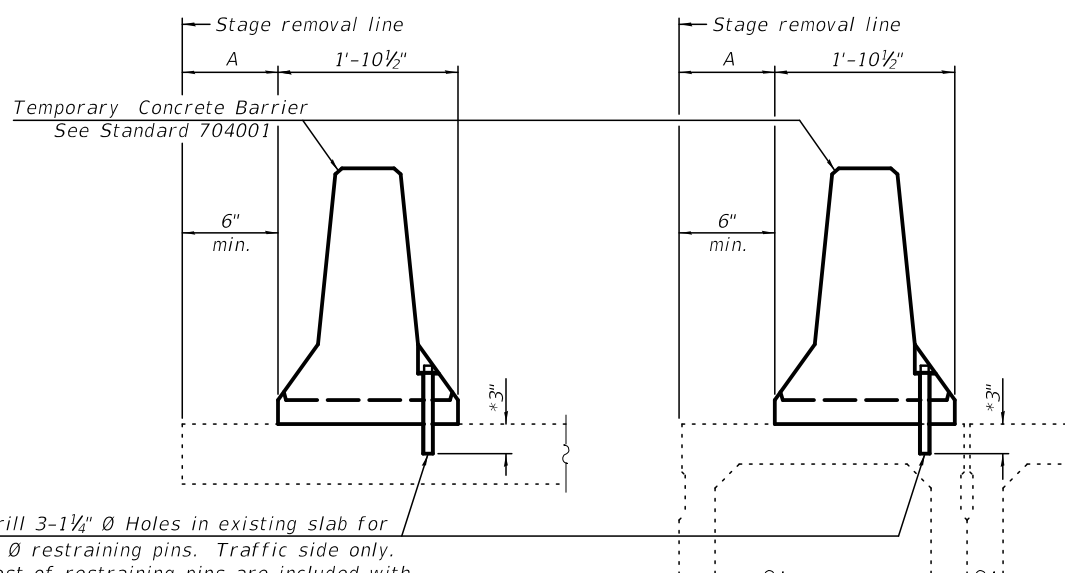

Drill 3-1/4" Ø Holes in existing slab for 1" Ø restraining pins. Traffic side only. Cost of restraining pins are included with Temporary Concrete Barrier. No restraint is required when "A" is greater than 3'-1".

EXISTING SLAB

EXISTING DECK BEAM

SECTIONS THRU SLAB OR DECK BEAM

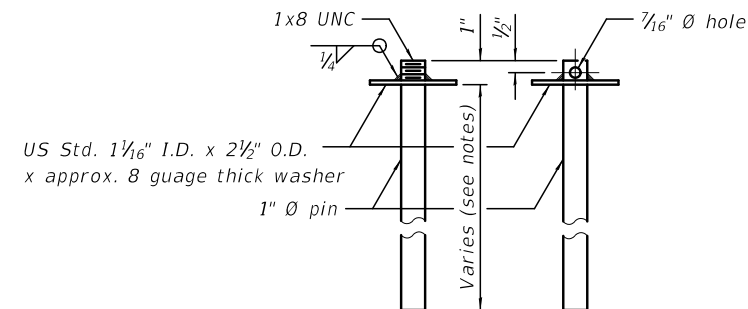

RESTRAINING PIN

US Std. 1 1/16" I.D. x 2 1/2" O.D. x approx. 8 gauge thick washer

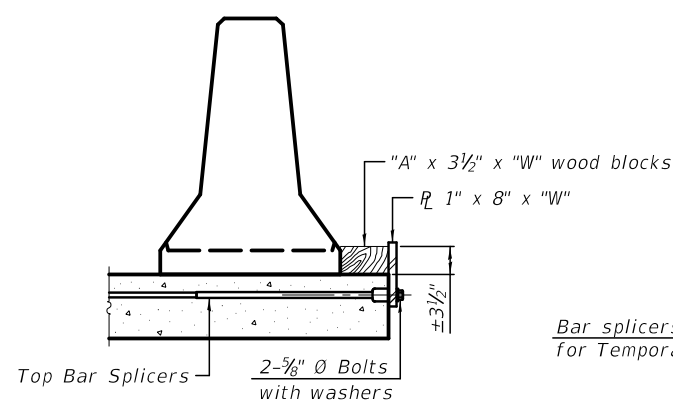

DETAIL I

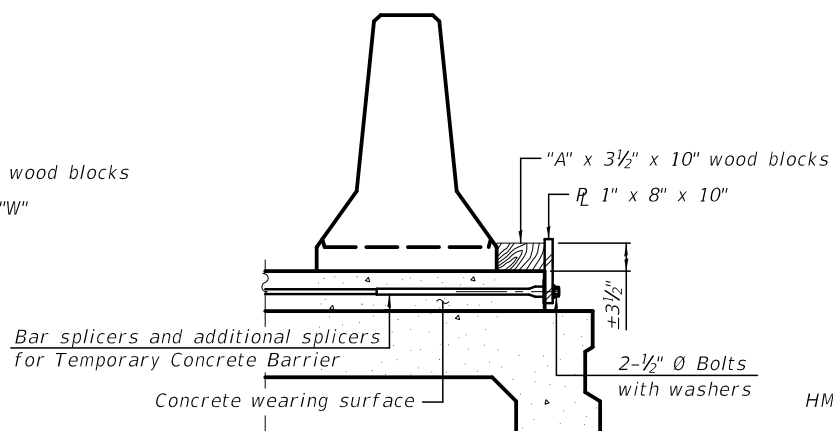

DETAIL II

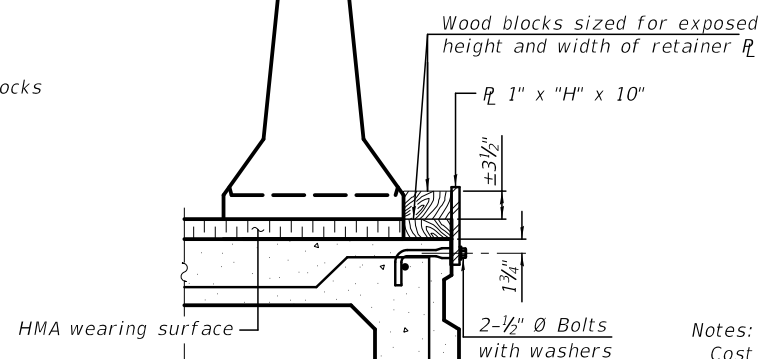

DETAIL III

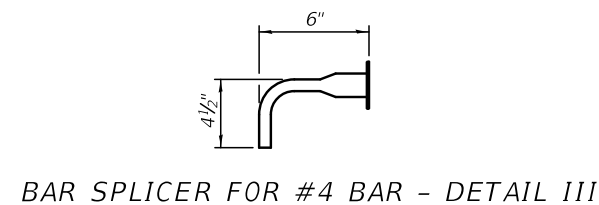

BAR SPLICER FOR #4 BAR - DETAIL III

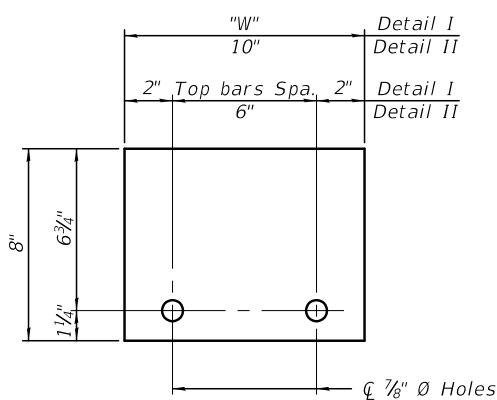

STEEL RETAINER R 1" x 8" x "W"
(Detail I and II)

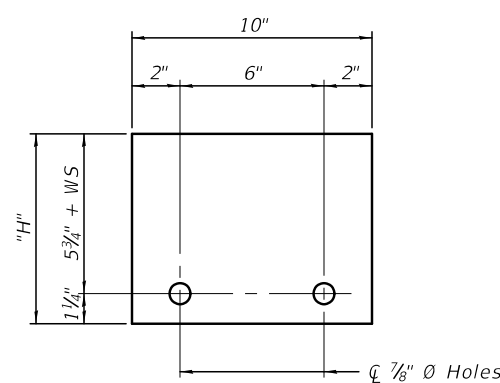

STEEL RETAINER R 1" x "H" x 10"
(Detail III)

Notes:

Cost of retainer assembly is included with Temporary Concrete Barrier. A retainer assembly shall be located at the approximate C of each temporary concrete barrier. The retainer plate shall not be removed until the concrete on the adjacent stage is ready to be poured. For Detail III applications the retainer plate shall not be removed until just prior to placing the adjacent beam. When the 'A' dimension is less than 1 1/2', the wood block shall be omitted and the barrier shall be placed in direct contact with the steel retainer plate. For deck beam applications the minimum required 'A' distance is 6" to accommodate the shear key clamping device.

Detail I - Installation for a new bridge deck or bridge slab.
Detail II - Installation for a new deck beam with an initial concrete wearing surface. Additional bar splicers shall be provided at 6'-0" centers and paired with the bar splicers of the concrete wearing surface reinforcement to accommodate the installation of the retainer assemblies. The cost of the additional bar splicers is included with the concrete wearing surface.
Detail III - Installation for a new deck beam with no initial wearing surface or with an initial hot-mix asphalt (HMA) wearing surface present. The deck beam directly beneath the temporary concrete barrier shall be fabricated with bar splicer inserts in the side of the beam, as detailed, to accommodate the installation of the retainer assemblies. A pair of bar splicers, 6" apart, shall be placed at 6'-0" centers along the length of the beam. The cost of the bar splicers is included with the deck beam.

PLOT DATE = 2/9/2024

R-27

2-17-2017



DESIGNED - FJW	REVISION
CHECKED - LAS	REVISION
SCALE - NONE	REVISION
DATE - 2/9/2024	REVISION
DRAWN - DJC	REVISION
CHECKED - LAS	REVISION

STATE OF ILLINOIS
DEPARTMENT OF TRANSPORTATION

TEMPORARY CONCRETE BARRIER FOR STAGE CONSTRUCTION
STRUCTURE NUMBER 022-3055

SHEET S-07 OF 36 SHEETS

F.A.U. RTE.	SECTION	COUNTY	TOTAL SHEETS	SHEET NO.
1479	14-00124-00-BR	DUPAGE	208	125
CONTRACT NO. 61J14				

ILLINOIS FED. AID PROJECT

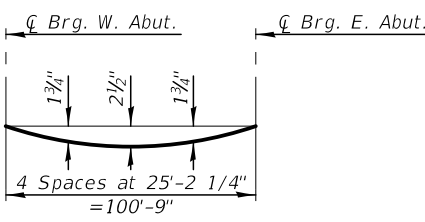
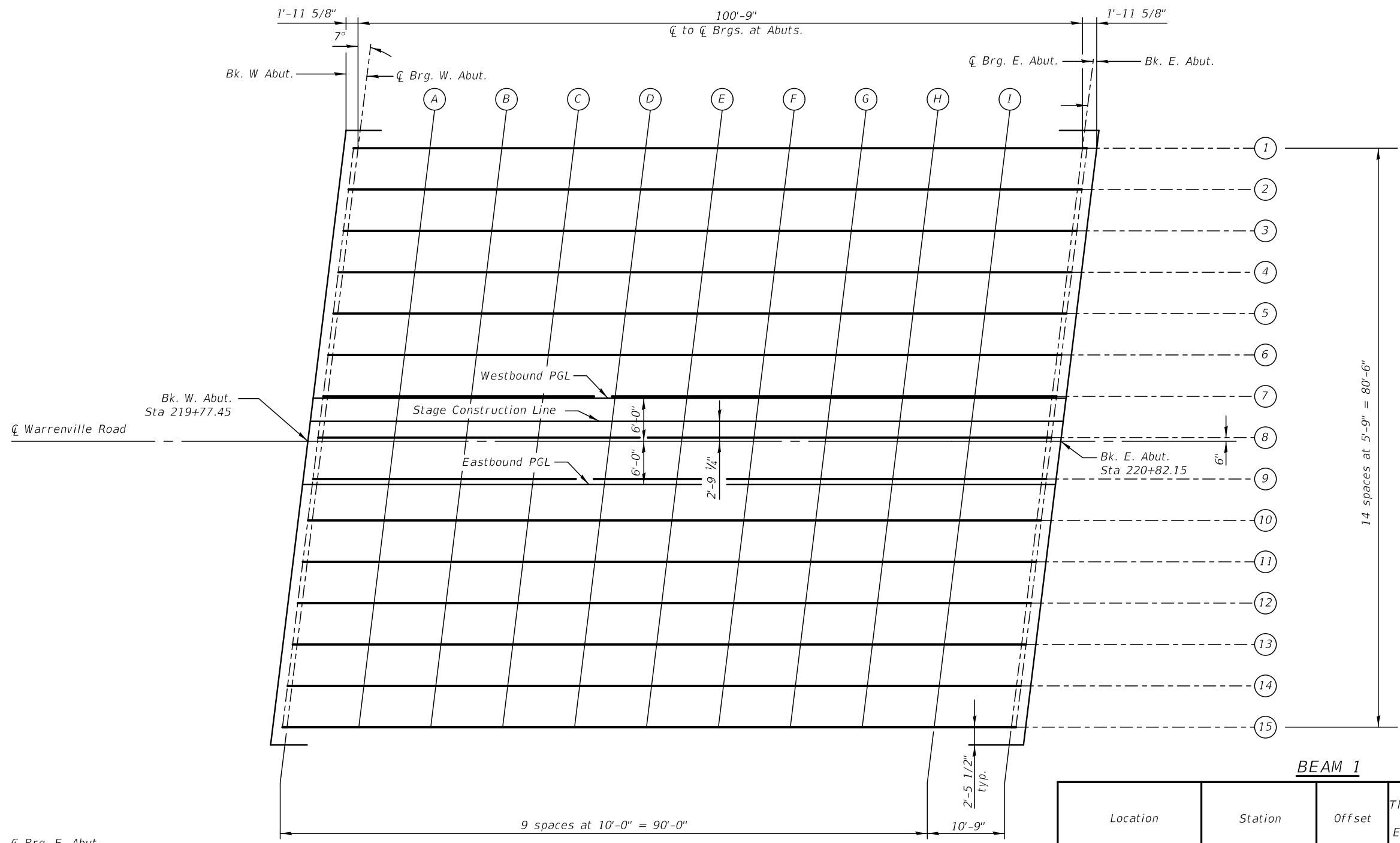

DEAD LOAD DEFLECTION DIAGRAM
 (Includes weight of concrete, excluding beams).

Note:
 The above deflections are not to be used in the field if the engineer is working from the Theoretical Grade Elevations Adjusted for Dead Load Deflections as shown on drawings S-8 thru S-11.

BEAM 1

Location	Station	Offset	Theoretical Grade Elevations	Theoretical Grade Elevations Adjusted For Dead Load Deflection
Back of W. Abut	219+82.46	-40.75	676.75	676.75
CL Brg W. Abut	219+84.43	-40.75	676.74	676.74
A	219+94.43	-40.75	676.71	676.77
B	220+04.43	-40.75	676.66	676.77
C	220+14.43	-40.75	676.60	676.75
D	220+24.43	-40.75	676.53	676.71
E	220+34.43	-40.75	676.45	676.64
F	220+44.43	-40.75	676.35	676.53
G	220+54.43	-40.75	676.25	676.40
H	220+64.43	-40.75	676.13	676.24
I	220+74.43	-40.75	676.00	676.06
CL Brg E. Abut	220+85.18	-40.75	675.85	675.85
Back E Abut	220+87.15	-40.75	675.82	675.82

PLOT DATE = 2/9/2024

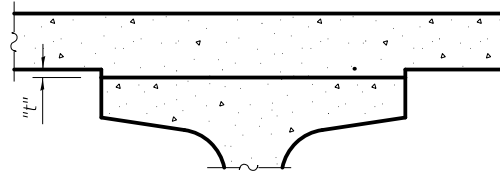

To determine "t": After all precast prestressed beams have been erected, elevations of the top flanges of the beams shall be taken at intervals shown below and on sheets S-8, S-10 & S-11. These elevations subtracted from the "Theoretical Grade Elevations Adjusted for Dead Load Deflections" shown below and on sheets S-8, S-10 & S-11, minus slab thickness, equals the fillet heights "t" above top flanges of beams.

FILLET HEIGHTS

BEAM 2

Location	Station	Offset	Theoretical Grade Elevations	Theoretical Grade Elevations Adjusted For Dead Load Deflection
Back of W. Abut	219+81.75	-35.00	676.67	676.67
CL Brg W. Abut	219+83.72	-35.00	676.66	676.66
A	219+93.72	-35.00	676.62	676.68
B	220+03.72	-35.00	676.58	676.69
C	220+13.72	-35.00	676.52	676.67
D	220+23.72	-35.00	676.45	676.63
E	220+33.72	-35.00	676.37	676.56
F	220+43.72	-35.00	676.27	676.45
G	220+53.72	-35.00	676.17	676.32
H	220+63.72	-35.00	676.05	676.16
I	220+73.72	-35.00	675.92	675.98
CL Brg E. Abut	220+84.47	-35.00	675.77	675.77
Back E Abut	220+86.45	-35.00	675.74	675.74

BEAM 3

Location	Station	Offset	Theoretical Grade Elevations	Theoretical Grade Elevations Adjusted For Dead Load Deflection
Back of W. Abut	219+81.04	-29.25	676.58	676.58
CL Brg W. Abut	219+83.02	-29.25	676.58	676.58
A	219+93.02	-29.25	676.54	676.60
B	220+03.02	-29.25	676.49	676.60
C	220+13.02	-29.25	676.44	676.59
D	220+23.02	-29.25	676.37	676.55
E	220+33.02	-29.25	676.29	676.48
F	220+43.02	-29.25	676.19	676.37
G	220+53.02	-29.25	676.09	676.24
H	220+63.02	-29.25	675.97	676.08
I	220+73.02	-29.25	675.85	675.91
CL Brg E. Abut	220+83.77	-29.25	675.70	675.70
Back E Abut	220+85.74	-29.25	675.67	675.67

BEAM 4

Location	Station	Offset	Theoretical Grade Elevations	Theoretical Grade Elevations Adjusted For Dead Load Deflection
Back of W. Abut	219+80.34	-23.50	676.50	676.50
CL Brg W. Abut	219+82.31	-23.50	676.49	676.49
A	219+92.31	-23.50	676.46	676.52
B	220+02.31	-23.50	676.41	676.52
C	220+12.31	-23.50	676.35	676.50
D	220+22.31	-23.50	676.29	676.47
E	220+32.31	-23.50	676.21	676.40
F	220+42.31	-23.50	676.11	676.29
G	220+52.31	-23.50	676.01	676.16
H	220+62.31	-23.50	675.90	676.01
I	220+72.31	-23.50	675.77	675.83
CL Brg E. Abut	220+83.06	-23.50	675.62	675.62
Back E Abut	220+85.03	-23.50	675.59	675.59

BEAM 5

Location	Station	Offset	Theoretical Grade Elevations	Theoretical Grade Elevations Adjusted For Dead Load Deflection
Back of W. Abut	219+79.63	-17.75	676.41	676.41
CL Brg W. Abut	219+81.60	-17.75	676.41	676.41
A	219+91.60	-17.75	676.37	676.43
B	220+01.60	-17.75	676.33	676.44
C	220+11.60	-17.75	676.27	676.42
D	220+21.60	-17.75	676.20	676.38
E	220+31.60	-17.75	676.12	676.31
F	220+41.60	-17.75	676.03	676.21
G	220+51.60	-17.75	675.93	676.08
H	220+61.60	-17.75	675.82	675.93
I	220+71.60	-17.75	675.69	675.75
CL Brg E. Abut	220+82.35	-17.75	675.55	675.55
Back E Abut	220+84.33	-17.75	675.52	675.52

BEAM 6

Location	Station	Offset	Theoretical Grade Elevations	Theoretical Grade Elevations Adjusted For Dead Load Deflection
Back of W. Abut	219+78.93	-12.00	676.33	676.33
CL Brg W. Abut	219+80.90	-12.00	676.32	676.32
A	219+90.90	-12.00	676.29	676.35
B	220+00.90	-12.00	676.25	676.36
C	220+10.90	-12.00	676.19	676.34
D	220+20.90	-12.00	676.12	676.30
E	220+30.90	-12.00	676.04	676.23
F	220+40.90	-12.00	675.95	676.13
G	220+50.90	-12.00	675.85	676.00
H	220+60.90	-12.00	675.74	675.85
I	220+70.90	-12.00	675.62	675.68
CL Brg E. Abut	220+81.65	-12.00	675.47	675.47
Back E Abut	220+83.62	-12.00	675.44	675.44

BEAM 7

Location	Station	Offset	Theoretical Grade Elevations	Theoretical Grade Elevations Adjusted For Dead Load Deflection
Back of W. Abut	219+78.22	-6.25	676.24	676.24
CL Brg W. Abut	219+80.19	-6.25	676.24	676.24
A	219+90.19	-6.25	676.21	676.27
B	220+00.19	-6.25	676.16	676.27
C	220+10.19	-6.25	676.11	676.26
D	220+20.19	-6.25	676.04	676.22
E	220+30.19	-6.25	675.96	676.15
F	220+40.19	-6.25	675.88	676.06
G	220+50.19	-6.25	675.77	675.92
H	220+60.19	-6.25	675.66	675.77
I	220+70.19	-6.25	675.54	675.60
CL Brg E. Abut	220+80.94	-6.25	675.39	675.39
Back E Abut	220+82.92	-6.25	675.36	675.36

PLOT DATE = 2/9/2024

KNIGHT
Member of WSP

DESIGNED - FJW	REVISION
CHECKED - LAS	REVISION
SCALE - NONE	REVISION
DATE - 2/9/2024	REVISION

DESIGNED - FJW	REVISION
CHECKED - LAS	REVISION
DRAWN - DJC	REVISION
CHECKED - LAS	REVISION

STATE OF ILLINOIS
DEPARTMENT OF TRANSPORTATION

TOP OF SLAB ELEVATIONS
STRUCTURE NUMBER 022-3055

SHEET S-09 OF 36 SHEETS

F.A.U. RTE.	SECTION	COUNTY	TOTAL SHEETS	SHEET NO.
1479	14-00124-00-BR	DUPAGE	208	127
CONTRACT NO. 61J14				
ILLINOIS FED. AID PROJECT				

WB PGL

Location	Station	Offset	Theoretical Grade Elevations	Theoretical Grade Elevations Adjusted For Dead Load Deflection
Back of W. Abut	219+78.19	-6.00	676.24	676.24
CL Brg W. Abut	219+80.16	-6.00	676.24	676.24
A	219+90.16	-6.00	676.20	676.26
B	220+00.16	-6.00	676.16	676.27
C	220+10.16	-6.00	676.11	676.26
D	220+20.16	-6.00	676.04	676.22
E	220+30.16	-6.00	675.96	676.15
F	220+40.16	-6.00	675.87	676.05
G	220+50.16	-6.00	675.77	675.92
H	220+60.16	-6.00	675.66	675.77
I	220+70.16	-6.00	675.54	675.60
CL Brg E. Abut	220+80.91	-6.00	675.39	675.39
Back E Abut	220+82.88	-6.00	675.36	675.36

STAGE CONSTRUCTION LINE

Location	Station	Offset	Theoretical Grade Elevations	Theoretical Grade Elevations Adjusted For Dead Load Deflection
Back of W. Abut	219+77.79	-2.77	676.19	676.19
CL Brg W. Abut	219+79.77	-2.77	676.19	676.19
A	219+89.77	-2.77	676.16	676.22
B	219+99.77	-2.77	676.11	676.22
C	220+09.77	-2.77	676.06	676.21
D	220+19.77	-2.77	675.99	676.17
E	220+29.77	-2.77	675.92	676.11
F	220+39.77	-2.77	675.83	676.01
G	220+49.77	-2.77	675.73	675.88
H	220+59.77	-2.77	675.61	675.72
I	220+69.77	-2.77	675.49	675.55
CL Brg E. Abut	220+80.52	-2.77	675.35	675.35
Back E Abut	220+82.49	-2.77	675.32	675.32

BEAM 8

Location	Station	Offset	Theoretical Grade Elevations	Theoretical Grade Elevations Adjusted For Dead Load Deflection
Back of W. Abut	219+77.51	-0.50	676.22	676.22
CL Brg W. Abut	219+79.49	-0.50	676.22	676.22
A	219+89.49	-0.50	676.19	676.25
B	219+99.49	-0.50	676.14	676.25
C	220+09.49	-0.50	676.09	676.24
D	220+19.49	-0.50	676.02	676.20
E	220+29.49	-0.50	675.95	676.14
F	220+39.49	-0.50	675.86	676.04
G	220+49.49	-0.50	675.76	675.91
H	220+59.49	-0.50	675.65	675.76
I	220+69.49	-0.50	675.53	675.59
CL Brg E. Abut	220+80.24	-0.50	675.38	675.38
Back E Abut	220+82.21	-0.50	675.35	675.35

∅ Warrenville Road

Location	Station	Offset	Theoretical Grade Elevations	Theoretical Grade Elevations Adjusted For Dead Load Deflection
Back of W. Abut	219+77.45	0.00	676.23	676.23
CL Brg W. Abut	219+79.43	0.00	676.23	676.23
A	219+89.43	0.00	676.19	676.25
B	219+99.43	0.00	676.15	676.26
C	220+09.43	0.00	676.10	676.25
D	220+19.43	0.00	676.03	676.21
E	220+29.43	0.00	675.95	676.14
F	220+39.43	0.00	675.87	676.05
G	220+49.43	0.00	675.77	675.92
H	220+59.43	0.00	675.66	675.77
I	220+69.43	0.00	675.53	675.59
CL Brg E. Abut	220+80.18	0.00	675.39	675.39
Back E Abut	220+82.15	0.00	675.36	675.36

BEAM 9

Location	Station	Offset	Theoretical Grade Elevations	Theoretical Grade Elevations Adjusted For Dead Load Deflection
Back of W. Abut	219+76.81	5.25	676.26	676.26
CL Brg W. Abut	219+78.78	5.25	676.25	676.25
A	219+88.78	5.25	676.22	676.28
B	219+98.78	5.25	676.18	676.29
C	220+08.78	5.25	676.13	676.28
D	220+18.78	5.25	676.06	676.24
E	220+28.78	5.25	675.99	676.18
F	220+38.78	5.25	675.90	676.08
G	220+48.78	5.25	675.80	675.95
H	220+58.78	5.25	675.69	675.80
I	220+68.78	5.25	675.57	675.63
CL Brg E. Abut	220+79.53	5.25	675.42	675.42
Back E Abut	220+81.50	5.25	675.40	675.40

EB PGL

Location	Station	Offset	Theoretical Grade Elevations	Theoretical Grade Elevations Adjusted For Dead Load Deflection
Back of W. Abut	219+76.72	6.00	676.24	676.24
CL Brg W. Abut	219+78.69	6.00	676.24	676.24
A	219+88.69	6.00	676.21	676.27
B	219+98.69	6.00	676.17	676.28
C	220+08.69	6.00	676.11	676.26
D	220+18.69	6.00	676.05	676.23
E	220+28.69	6.00	675.97	676.16
F	220+38.69	6.00	675.89	676.07
G	220+48.69	6.00	675.79	675.94
H	220+58.69	6.00	675.68	675.79
I	220+68.69	6.00	675.55	675.61
CL Brg E. Abut	220+79.44	6.00	675.41	675.41
Back E Abut	220+81.41	6.00	675.38	675.38

PLOT DATE = 2/9/2024



DESIGNED - FJW	REVISION
CHECKED - LAS	REVISION
SCALE - NONE	REVISION
DATE - 2/9/2024	REVISION
DRAWN - DJC	REVISION
CHECKED - LAS	REVISION

DESIGNED - FJW	REVISION
CHECKED - LAS	REVISION
DRAWN - DJC	REVISION
CHECKED - LAS	REVISION

STATE OF ILLINOIS
DEPARTMENT OF TRANSPORTATION

TOP OF SLAB ELEVATIONS
STRUCTURE NUMBER 022-3055

SHEET S-10 OF 36 SHEETS

F.A.U. RTE.	SECTION	COUNTY	TOTAL SHEETS	SHEET NO.
1479	14-00124-00-BR	DUPAGE	208	128
CONTRACT NO. 61J14				
ILLINOIS FED. AID PROJECT				

BEAM 10

Location	Station	Offset	Theoretical Grade Elevations	Theoretical Grade Elevations Adjusted For Dead Load Deflection
Back of W. Abut	219+76.10	11.00	676.15	676.15
CL Brg W. Abut	219+78.07	11.00	676.14	676.14
A	219+88.07	11.00	676.11	676.17
B	219+98.07	11.00	676.07	676.18
C	220+08.07	11.00	676.02	676.17
D	220+18.07	11.00	675.95	676.13
E	220+28.07	11.00	675.88	676.07
F	220+38.07	11.00	675.79	675.97
G	220+48.07	11.00	675.69	675.84
H	220+58.07	11.00	675.58	675.69
I	220+68.07	11.00	675.46	675.52
CL Brg E. Abut	220+78.82	11.00	675.32	675.32
Back E Abut	220+80.80	11.00	675.29	675.29

BEAM 11

Location	Station	Offset	Theoretical Grade Elevations	Theoretical Grade Elevations Adjusted For Dead Load Deflection
Back of W. Abut	219+75.40	16.75	676.03	676.03
CL Brg W. Abut	219+77.37	16.75	676.03	676.03
A	219+87.37	16.75	676.00	676.06
B	219+97.37	16.75	675.96	676.07
C	220+07.37	16.75	675.91	676.06
D	220+17.37	16.75	675.84	676.02
E	220+27.37	16.75	675.77	675.96
F	220+37.37	16.75	675.68	675.86
G	220+47.37	16.75	675.59	675.74
H	220+57.37	16.75	675.48	675.59
I	220+67.37	16.75	675.36	675.42
CL Brg E. Abut	220+78.12	16.75	675.21	675.21
Back E Abut	220+80.09	16.75	675.19	675.19

BEAM 12

Location	Station	Offset	Theoretical Grade Elevations	Theoretical Grade Elevations Adjusted For Dead Load Deflection
Back of W. Abut	219+74.69	22.50	675.92	675.92
CL Brg W. Abut	219+76.66	22.50	675.91	675.91
A	219+86.66	22.50	675.89	675.95
B	219+96.66	22.50	675.85	675.96
C	220+06.66	22.50	675.80	675.95
D	220+16.66	22.50	675.73	675.91
E	220+26.66	22.50	675.66	675.85
F	220+36.66	22.50	675.57	675.75
G	220+46.66	22.50	675.48	675.63
H	220+56.66	22.50	675.37	675.48
I	220+66.66	22.50	675.25	675.31
CL Brg E. Abut	220+77.41	22.50	675.11	675.11
Back E Abut	220+79.39	22.50	675.08	675.08

BEAM 13

Location	Station	Offset	Theoretical Grade Elevations	Theoretical Grade Elevations Adjusted For Dead Load Deflection
Back of W. Abut	219+73.98	28.25	675.80	675.80
CL Brg W. Abut	219+75.96	28.25	675.80	675.80
A	219+85.96	28.25	675.77	675.83
B	219+95.96	28.25	675.73	675.84
C	220+05.96	28.25	675.68	675.83
D	220+15.96	28.25	675.62	675.80
E	220+25.96	28.25	675.55	675.74
F	220+35.96	28.25	675.47	675.65
G	220+45.96	28.25	675.37	675.52
H	220+55.96	28.25	675.26	675.37
I	220+65.96	28.25	675.14	675.20
CL Brg E. Abut	220+76.71	28.25	675.00	675.00
Back E Abut	220+78.68	28.25	674.98	674.98

BEAM 14

Location	Station	Offset	Theoretical Grade Elevations	Theoretical Grade Elevations Adjusted For Dead Load Deflection
Back of W. Abut	219+73.28	34.00	675.69	675.69
CL Brg W. Abut	219+75.25	34.00	675.69	675.69
A	219+85.25	34.00	675.66	675.72
B	219+95.25	34.00	675.62	675.73
C	220+05.25	34.00	675.57	675.72
D	220+15.25	34.00	675.51	675.69
E	220+25.25	34.00	675.44	675.63
F	220+35.25	34.00	675.36	675.54
G	220+45.25	34.00	675.26	675.41
H	220+55.25	34.00	675.16	675.27
I	220+65.25	34.00	675.04	675.10
CL Brg E. Abut	220+76.00	34.00	674.90	674.90
Back E Abut	220+77.97	34.00	674.87	674.87

BEAM 15

Location	Station	Offset	Theoretical Grade Elevations	Theoretical Grade Elevations Adjusted For Dead Load Deflection
Back of W. Abut	219+72.57	39.75	675.58	675.58
CL Brg W. Abut	219+74.54	39.75	675.57	675.57
A	219+84.54	39.75	675.55	675.61
B	219+94.54	39.75	675.51	675.62
C	220+04.54	39.75	675.46	675.61
D	220+14.54	39.75	675.40	675.58
E	220+24.54	39.75	675.33	675.52
F	220+34.54	39.75	675.25	675.43
G	220+44.54	39.75	675.15	675.30
H	220+54.54	39.75	675.05	675.16
I	220+64.54	39.75	674.93	674.99
CL Brg E. Abut	220+75.29	39.75	674.79	674.79
Back E Abut	220+77.27	39.75	674.77	674.77

PLOT DATE = 2/9/2024



DESIGNED - FJW	REVISION
CHECKED - LAS	REVISION
SCALE - NONE	REVISION
DATE - 2/9/2024	REVISION
DRAWN - DJC	REVISION
CHECKED - LAS	REVISION

DESIGNED - FJW	REVISION
CHECKED - LAS	REVISION
DRAWN - DJC	REVISION
CHECKED - LAS	REVISION

STATE OF ILLINOIS
DEPARTMENT OF TRANSPORTATION

TOP OF SLAB ELEVATIONS
STRUCTURE NUMBER 022-3055

SHEET S-11 OF 36 SHEETS

F.A.U. RTE.	SECTION	COUNTY	TOTAL SHEETS	SHEET NO.
1479	14-00124-00-BR	DUPAGE	208	129
CONTRACT NO. 61J14				
ILLINOIS FED. AID PROJECT				

NORTH EDGE SHARED USE PATH

Location	Station	Offset	Theoretical Grade Elevations
West End - West Appr. Pavement	219+53.76	-43.21	676.82
A1	219+63.76	-43.21	676.82
A2	219+73.76	-43.21	676.81
East End - West Appr. Pavement	219+83.76	-43.21	676.78

NORTH CURB LINE

Location	Station	Offset (FT)	Theoretical Grade Elevations
West End - West Appr. Pavement	219+52.33	-31.50	676.65
A1	219+62.33	-31.50	676.65
A2	219+72.33	-31.50	676.64
East End - West Appr. Pavement	219+82.33	-31.50	676.61

WESTBOUND PGL

Location	Station	Offset	Theoretical Grade Elevations
West End - West Appr. Pavement	219+49.20	-6.00	676.26
A1	219+59.20	-6.00	676.27
A2	219+69.20	-6.00	676.26
East End - West Appr. Pavement	219+79.20	-6.00	676.24

STAGE CONSTRUCTION LINE

Location	Station	Offset	Theoretical Grade Elevations
West End - West Appr. Pavement	219+48.80	-2.77	676.21
A1	219+58.80	-2.77	676.22
A2	219+68.80	-2.77	676.21
East End - West Appr. Pavement	219+78.80	-2.77	676.19

WARRENVILLE ROAD

Location	Station	Offset	Theoretical Grade Elevations
West End - West Appr. Pavement	219+48.46	0.00	676.25
A1	219+58.46	0.00	676.25
A2	219+68.46	0.00	676.25
East End - West Appr. Pavement	219+78.46	0.00	676.23

EASTBOUND PGL

Location	Station	Offset	Theoretical Grade Elevations
West End - West Appr. Pavement	219+47.72	6.00	676.26
A1	219+57.72	6.00	676.27
A2	219+67.72	6.00	676.26
East End - West Appr. Pavement	219+77.72	6.00	676.24

SOUTH CURB LINE

Location	Station	Offset	Theoretical Grade Elevations
West End - West Appr. Pavement	219+44.10	35.50	675.67
A1	219+54.10	35.50	675.68
A2	219+64.10	35.50	675.67
East End - West Appr. Pavement	219+74.10	35.50	675.66

SOUTH EDGE SIDEWALK

Location	Station	Offset	Theoretical Grade Elevations
West End - West Appr. Pavement	219+43.28	42.21	675.53
A1	219+53.28	42.21	675.54
A2	219+63.28	42.21	675.54
East End - West Appr. Pavement	219+73.28	42.21	675.53

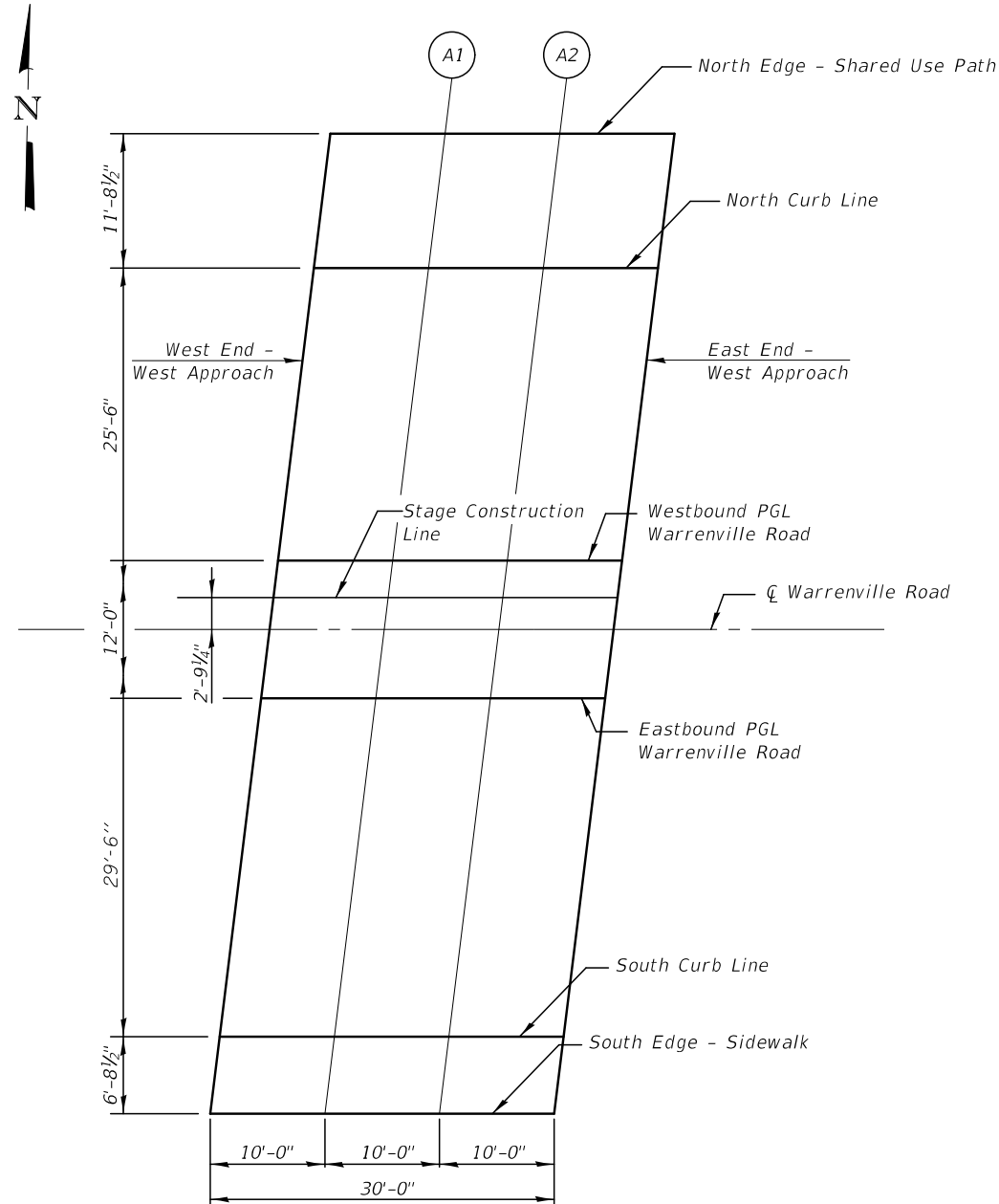

PLAN

E-AS 2-17-2017



DESIGNED - FJW	REVISION
CHECKED - LAS	REVISION
SCALE - NONE	REVISION
DATE - 2/9/2024	REVISION
DRAWN - DJC	REVISION
CHECKED - LAS	REVISION

STATE OF ILLINOIS
DEPARTMENT OF TRANSPORTATION

TOP OF WEST APPROACH SLAB ELEVATIONS
STRUCTURE NUMBER 022-3055

SHEET S-12 OF 36 SHEETS

F.A.U. RTE.	SECTION	COUNTY	TOTAL SHEETS	SHEET NO.
1479	14-00124-00-BR	DUPAGE	208	130
CONTRACT NO. 61J14				
ILLINOIS FED. AID PROJECT				

PLOT DATE = 2/9/2024

NORTH EDGE SHARED USE PATH

Location	Station	Offset	Theoretical Grade Elevations
West End - East Appr. Pavement	220+86.45	-43.21	675.87
A1	220+96.45	-43.21	675.71
A2	221+06.45	-43.21	675.55
East End - East Appr. Pavement	221+16.45	-43.21	675.37

NORTH CURB LINE

Location	Station	Offset	Theoretical Grade Elevations
West End - East Appr. Pavement	222+85.01	-31.50	675.71
A1	220+95.01	-31.50	675.56
A2	221+05.01	-31.50	675.40
East End - East Appr. Pavement	221+15.01	-31.50	675.22

WESTBOUND PGL

Location	Station	Offset	Theoretical Grade Elevations
West End - East Appr. Pavement	220+81.88	-6.00	675.38
A1	220+91.88	-6.00	675.23
A2	221+01.88	-6.00	675.07
East End - East Appr. Pavement	221+11.88	-6.00	674.90

STAGE CONSTRUCTION LINE

Location	Station	Offset	Theoretical Grade Elevations
West End - East Appr. Pavement	220+81.48	-2.77	675.33
A1	220+91.48	-2.77	675.18
A2	221+01.48	-2.77	675.03
East End - East Appr. Pavement	221+11.48	-2.77	674.85

WARRENVILLE ROAD

Location	Station	Offset	Theoretical Grade Elevations
West End - East Appr. Pavement	220+81.14	0.00	675.37
A1	220+91.14	0.00	675.23
A2	221+01.14	0.00	675.07
East End - East Appr. Pavement	221+11.14	0.00	674.90

EASTBOUND PGL

Location	Station	Offset	Theoretical Grade Elevations
West End - East Appr. Pavement	220+80.40	6.00	675.40
A1	220+90.40	6.00	675.25
A2	221+00.40	6.00	675.09
East End - East Appr. Pavement	221+10.40	6.00	674.92

SOUTH CURB LINE

Location	Station	Offset	Theoretical Grade Elevations
West End - East Appr. Pavement	220+76.78	35.50	674.86
A1	220+86.78	35.50	674.71
A2	220+96.78	35.50	674.56
East End - East Appr. Pavement	221+06.78	35.50	674.39

SOUTH EDGE SIDEWALK

Location	Station	Offset	Theoretical Grade Elevations
West End - East Appr. Pavement	220+75.96	42.21	674.73
A1	220+85.96	42.21	674.59
A2	220+95.96	42.21	675.44
East End - East Appr. Pavement	221+05.96	42.21	674.27

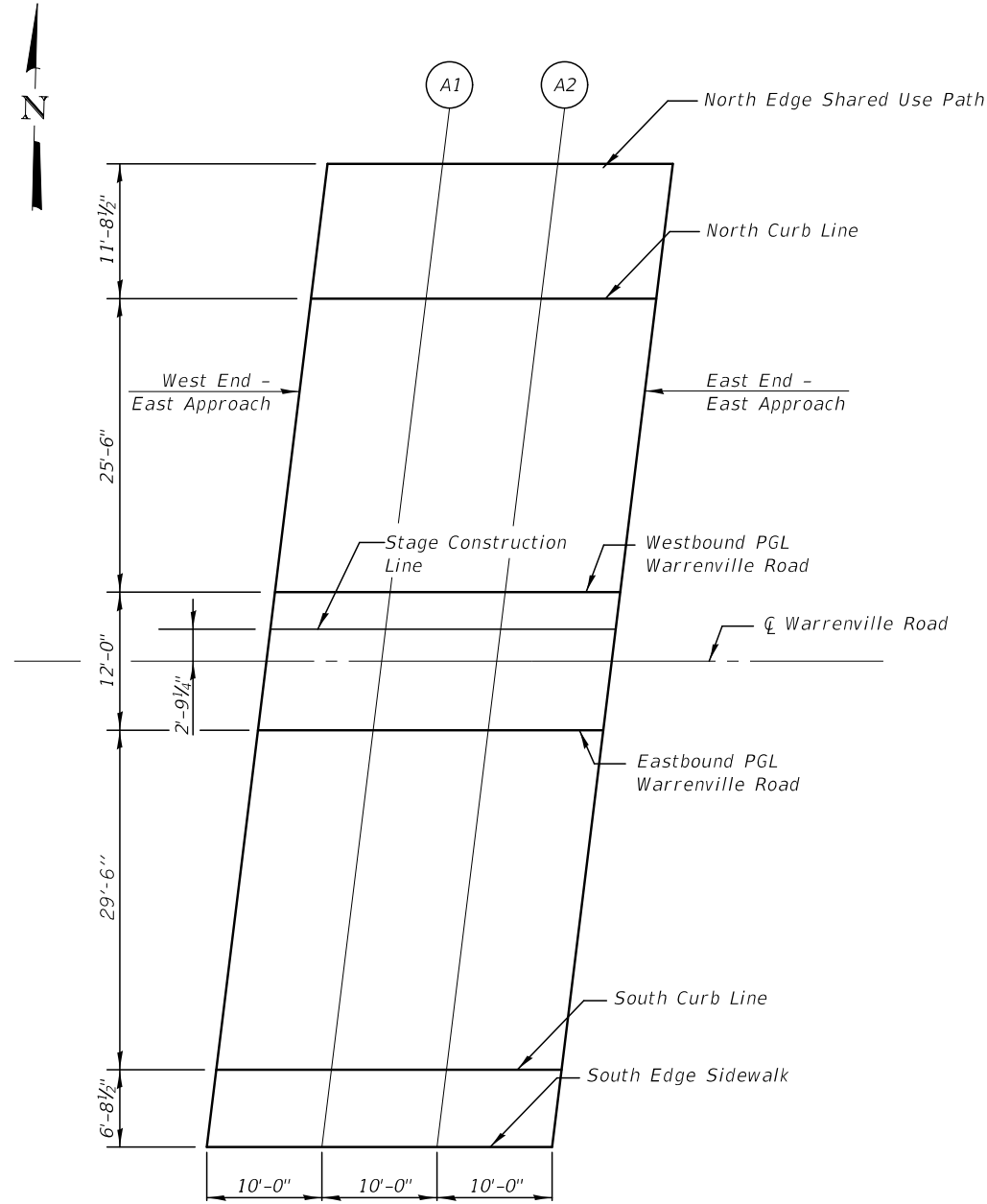

PLAN

PLOT DATE = 2/9/2024

KNIGHT
Member of WSP

DESIGNED - FJW	REVISION
CHECKED - LAS	REVISION
SCALE - NONE	REVISION
DATE - 2/9/2024	REVISION
DRAWN - DJC	REVISION
CHECKED - LAS	REVISION

DESIGNED - FJW	REVISION
CHECKED - LAS	REVISION
DRAWN - DJC	REVISION
CHECKED - LAS	REVISION

DESIGNED - FJW	REVISION
CHECKED - LAS	REVISION
DRAWN - DJC	REVISION
CHECKED - LAS	REVISION

STATE OF ILLINOIS
DEPARTMENT OF TRANSPORTATION

TOP OF EAST APPROACH SLAB ELEVATIONS
STRUCTURE NUMBER 022-3055

SHEET S-13 OF 36 SHEETS

F.A.U. RTE.	SECTION	COUNTY	TOTAL SHEETS	SHEET NO.
1479	14-00124-00-BR	DUPAGE	208	131
CONTRACT NO. 61J14				
ILLINOIS FED. AID PROJECT				

* Cut bars in field and use cutoffs at opposite end of deck. See field cutting diagram

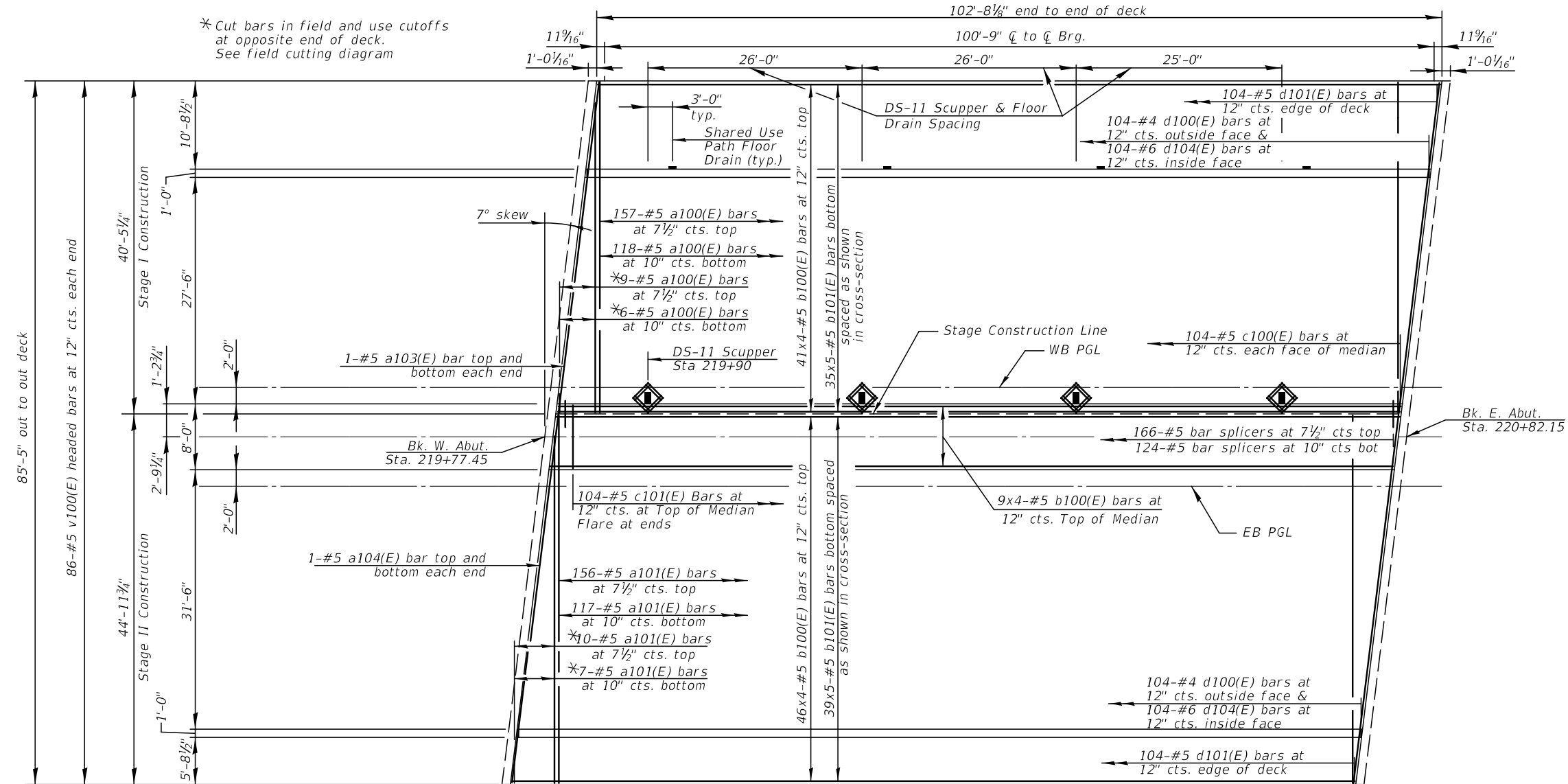

Notes:

- Bars indicated thus 20 x 3-#5 etc. indicates 20 lines of bars with 3 lengths per line.
- See sheet S-17 for diaphragm details.
- See Sheet S-15 for Shared Use Path and Parapet Details.
- See Sheet S-16 for Sidewalk & Parapet Details.
- See Sheet S-18 for Deck Misc. Details and Bill of Material.
- See Sheet S-21 and for Drainage Scupper Details and S-18 for Floor Drain Details.
- Extend floor drains and drainage scuppers to 6" below bottom flange of beams.
- See Sheet S-18 for slope of top of slab between WB PGL and EB median edge.

Min. Lap
#5 bar - 3'-6"

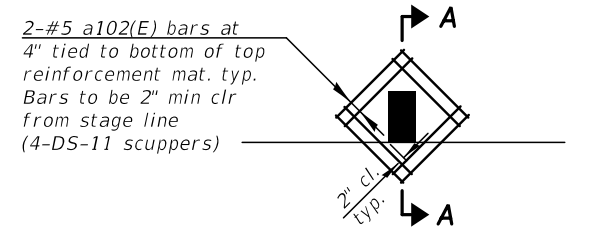

TYPICAL PLAN AT SCUPPERS

Note:
Cut longitudinal reinforcement to clear drainage scuppers.

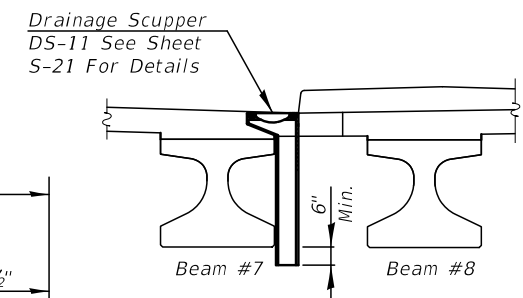

**SECTION A-A
DS-11 Scuppers**

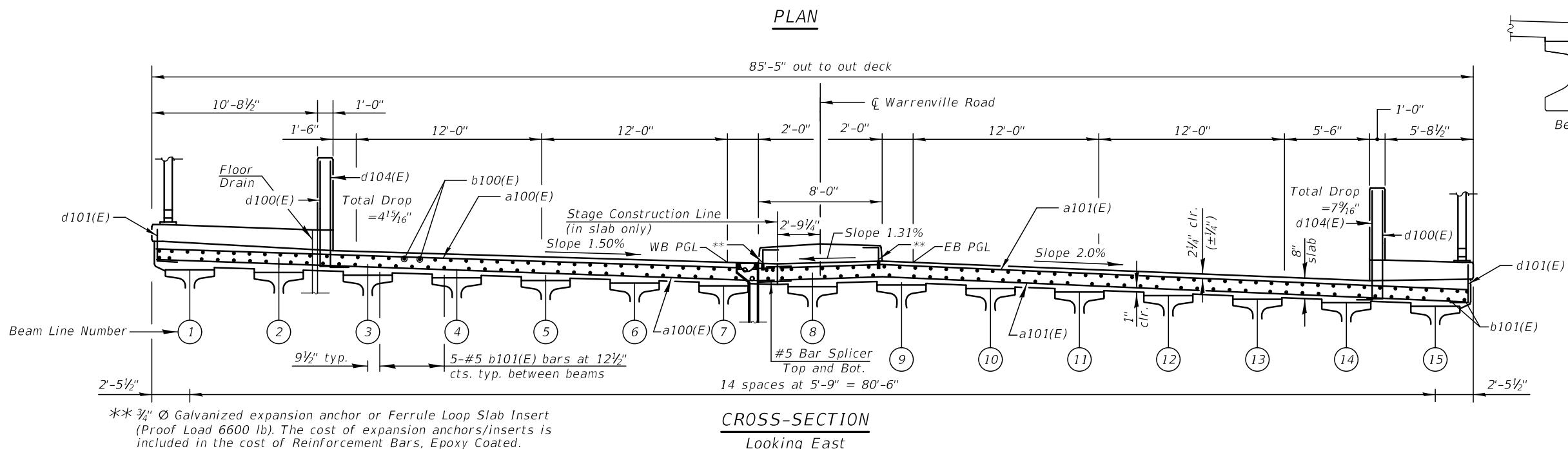

** 3/4" Ø Galvanized expansion anchor or Ferrule Loop Slab Insert (Proof Load 6600 lb). The cost of expansion anchors/inserts is included in the cost of Reinforcement Bars, Epoxy Coated.

**CROSS-SECTION
Looking East**

PLOT DATE = 2/9/2024



DESIGNED - FJW	REVISD
CHECKED - LAS	REVISD
DRAWN - DJC	REVISD
CHECKED - LAS	REVISD

STATE OF ILLINOIS
DEPARTMENT OF TRANSPORTATION

DECK PLAN AND CROSS SECTION
STRUCTURE NUMBER 022-3055

F.A.U. RTE.	SECTION	COUNTY	TOTAL SHEETS	SHEET NO.
1479	14-00124-00-BR	DUPAGE	208	132
CONTRACT NO. 61J14				

SHEET S-14 OF 36 SHEETS

ILLINOIS FED. AID PROJECT

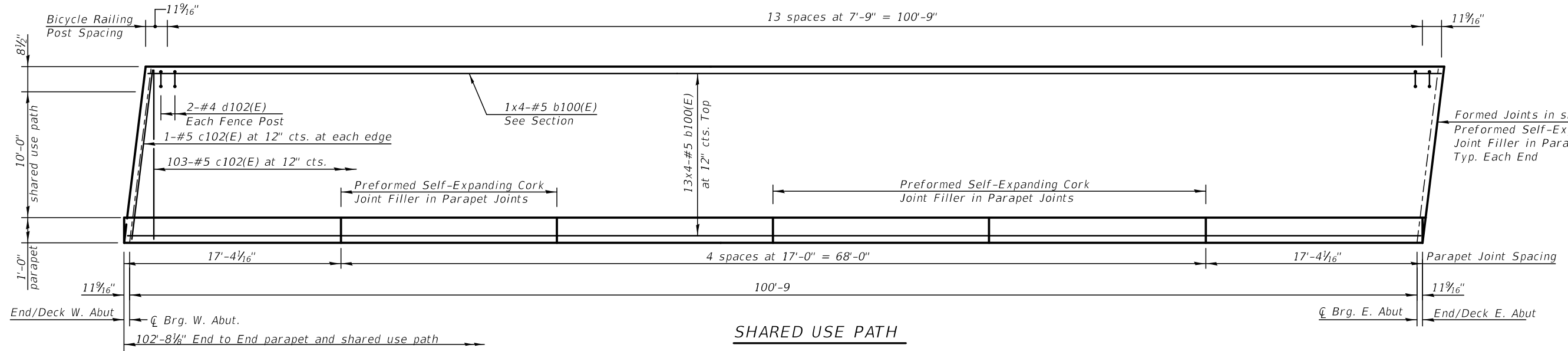
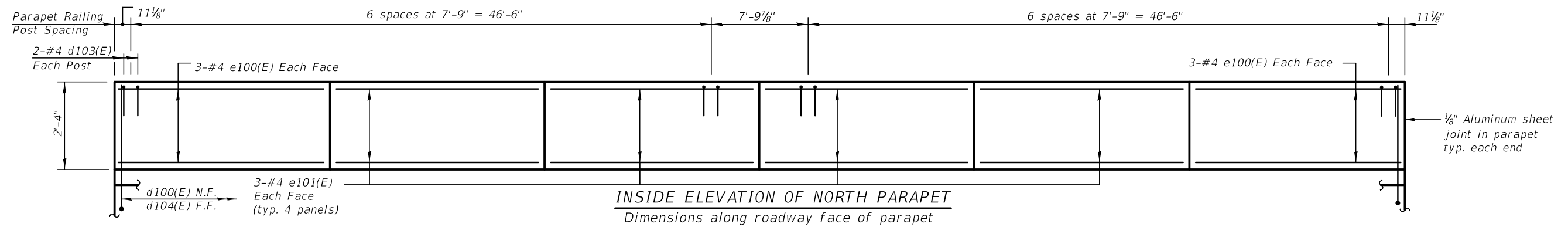

*Floor Drain, clamp and associated hardware not to be paid for separately

Notes:

- Bars indicated thus 20 x 3-#5 etc. indicates 20 lines of bars with 3 lengths per line.
- See Sheet S-18 for Deck Misc. Details and Bill of Materials.
- See Sheet S-29 for Bicycle and Parapet Railing Details.
- The top portion of aluminum floor drains shall be coated to minimize reaction with wet concrete.
- The clamping device and inserts shall be galvanized according to AASHTO M 232. Cost of clamping device included with Floor Drains.
- The 1/8" Aluminum sheet shall be ASTM B 209 alloy 3003-H14 and coated to minimize reaction with wet concrete. Cost included with Concrete Superstructure.
- The polyurethane sealant shall be according to Article 1050.04 of the Std. Spec. and the color shall be gray.
- Headed bars shall conform to ASTM A970 with threaded attachment; Class HA; and reinforcement bars conforming to ASTM A706. Cost included with Reinforcement Bars, Epoxy Coated.

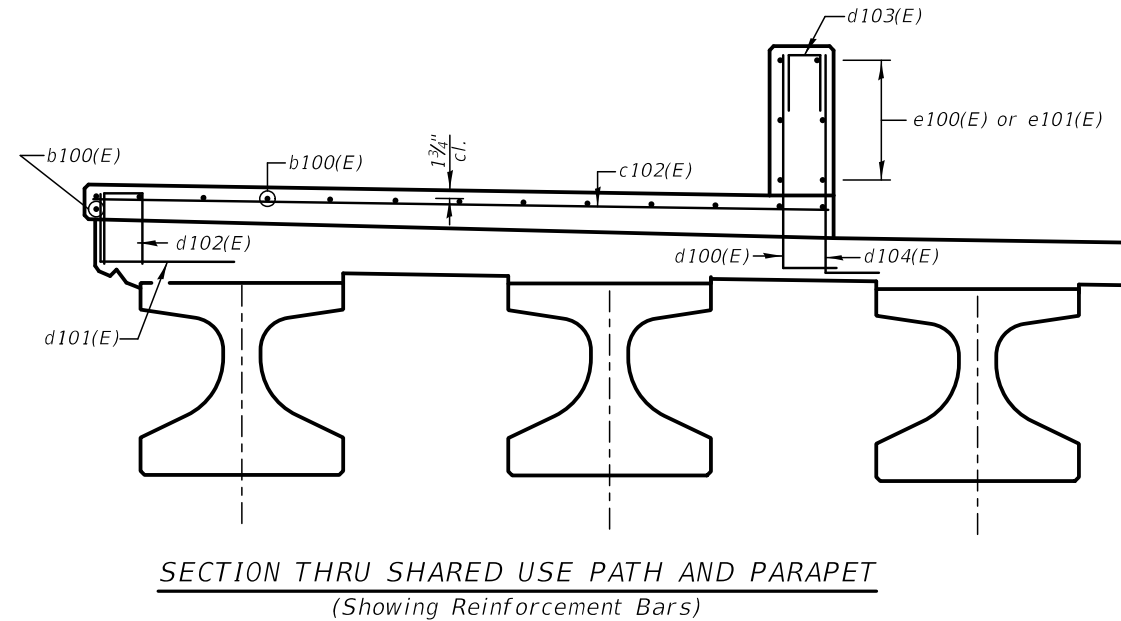
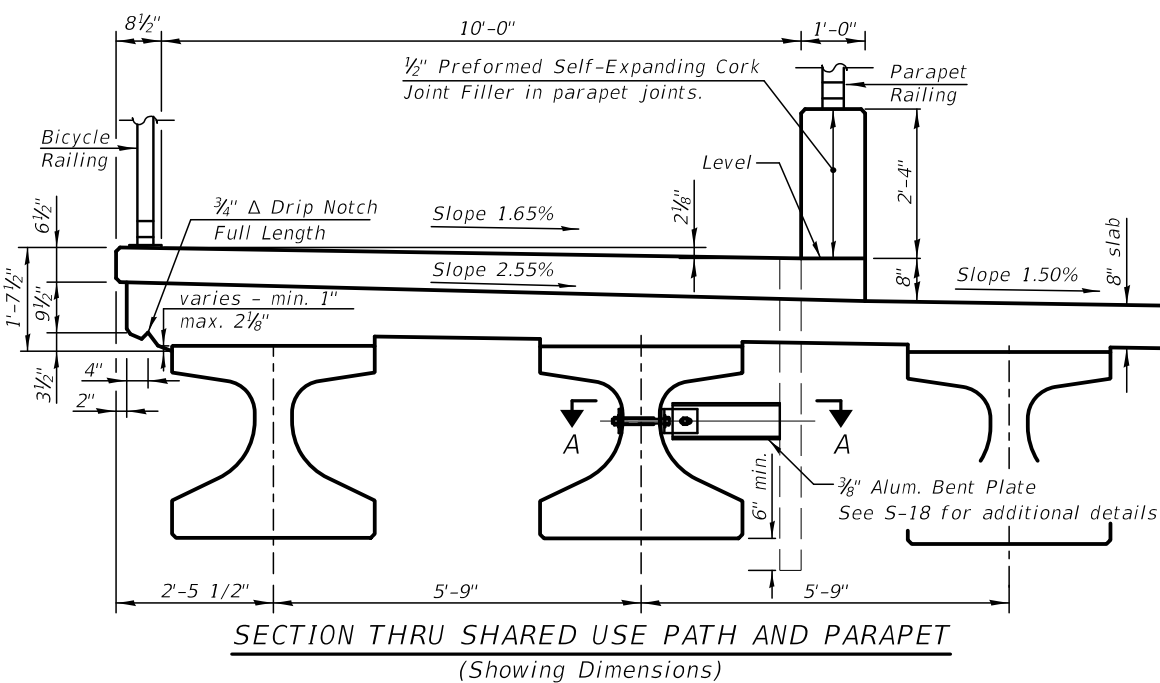

MIN. BAR LAPS:
#5 = 3'-6"

PLOT DATE = 2/9/2024



DESIGNED - FJW	REVIS
CHECKED - LAS	REVIS
DRAWN - DJC	REVIS
CHECKED - LAS	REVIS

STATE OF ILLINOIS
DEPARTMENT OF TRANSPORTATION

SHARED USE PATH AND PARAPET DETAILS
STRUCTURE NUMBER 022-3055

SHEET S-15 OF 36 SHEETS

F.A.U. RTE.	SECTION	COUNTY	TOTAL SHEETS	SHEET NO.
1479	14-00124-00-BR	DUPAGE	208	133
CONTRACT NO. 61J14				

ILLINOIS FED. AID PROJECT

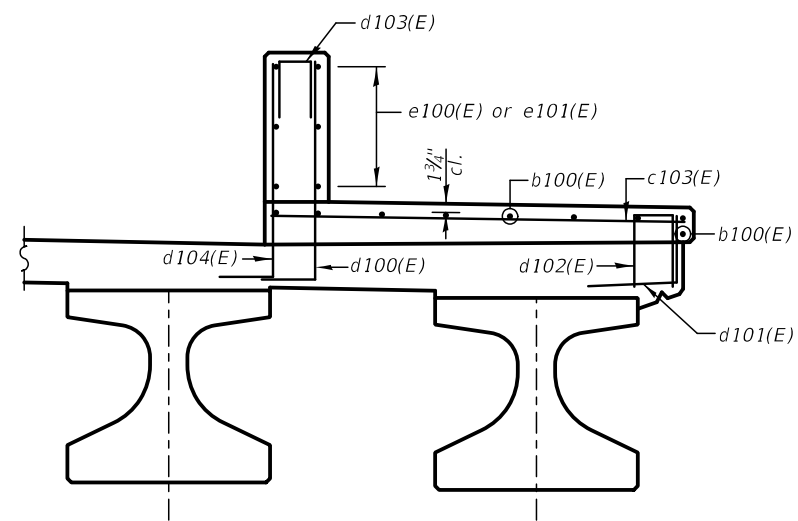
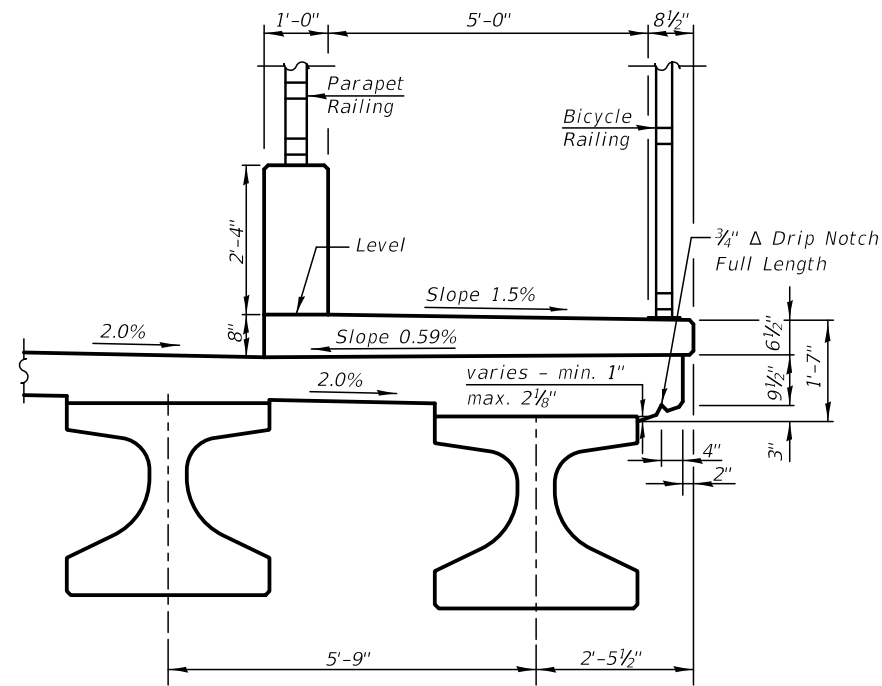
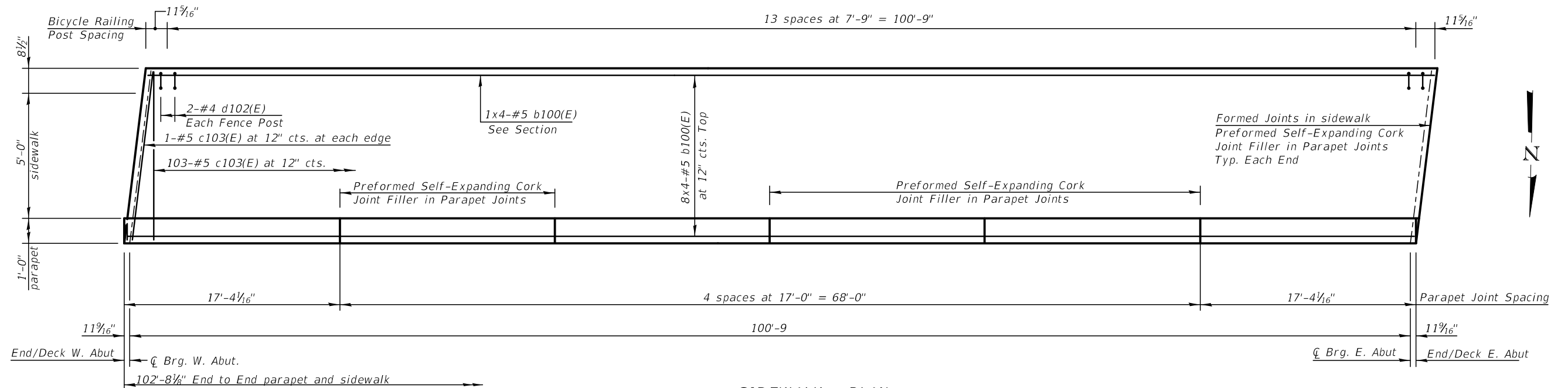
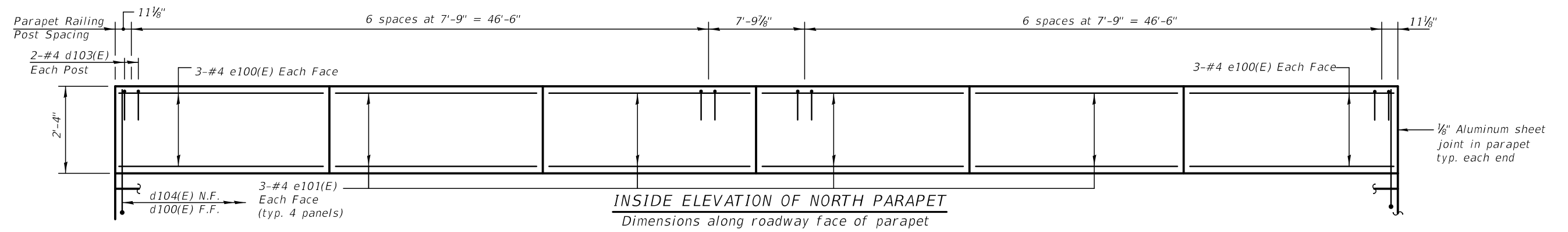

Notes:
Bars indicated thus 20 x 3-#5 etc. indicates 20 lines of bars with 3 lengths per line.
See Sheet S-18 for Deck Misc. Details and Bill of Materials.
See Sheet S-29 for Parapet and Bicycle Railing details.

MIN. BAR LAPS:
#5 bars = 3'-6"

PLOT DATE = 2/9/2024

KNIGHT
Member of WSP

DESIGNED - FJW	REVISION
CHECKED - LAS	REVISION
DRAWN - DJC	REVISION
CHECKED - LAS	REVISION

STATE OF ILLINOIS
DEPARTMENT OF TRANSPORTATION

SIDEWALK AND PARAPET DETAILS
STRUCTURE NUMBER 022-3055

SHEET S-16 OF 36 SHEETS

F.A.U. RTE.	SECTION	COUNTY	TOTAL SHEETS	SHEET NO.
1479	14-00124-00-BR	DUPAGE	208	134
CONTRACT NO. 61J14				

ILLINOIS FED. AID PROJECT

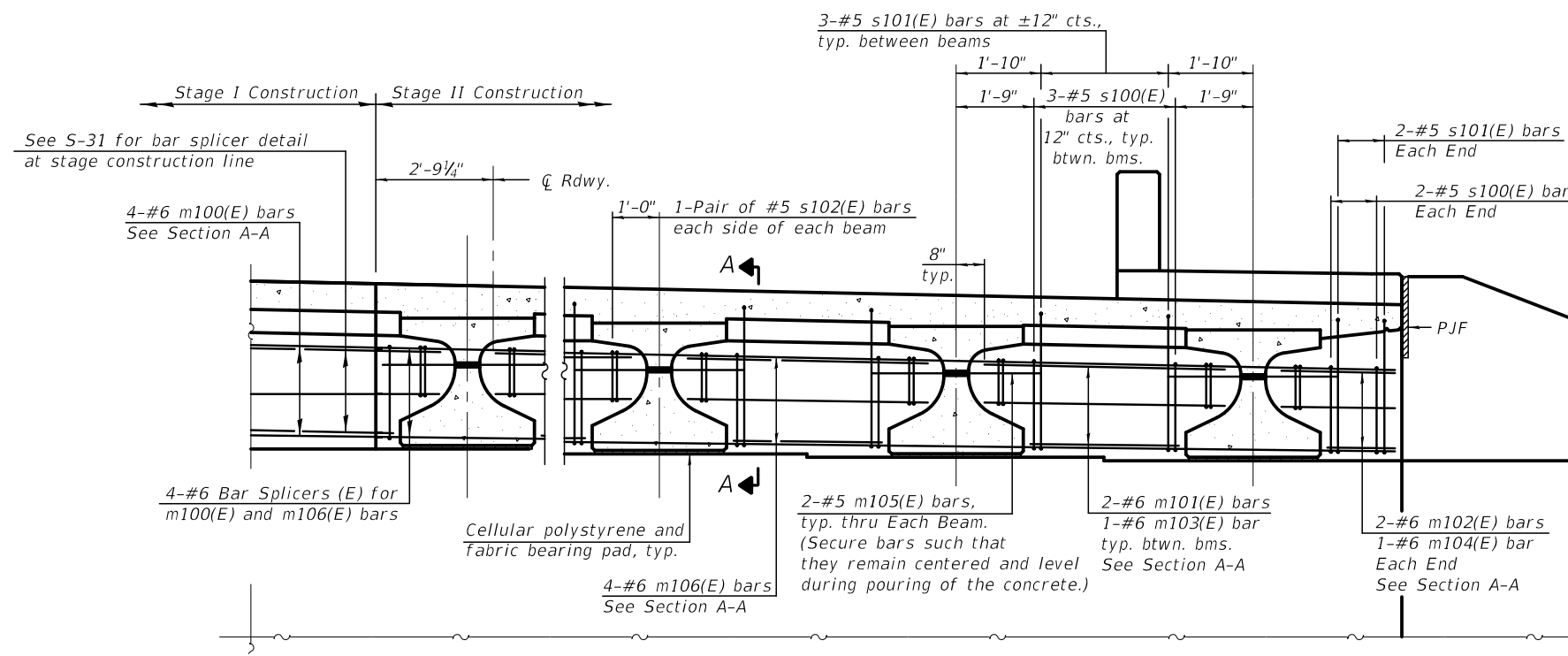

DIAPHRAGM AT ABUTMENT

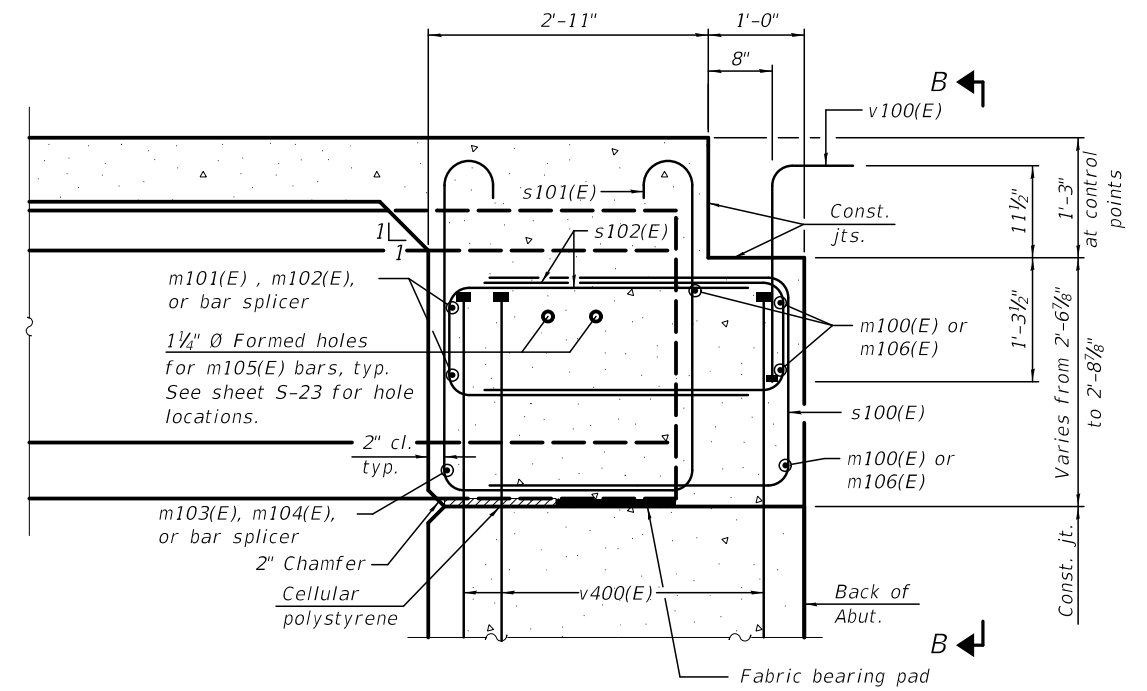

SECTION A-A
(at Rt. L's)

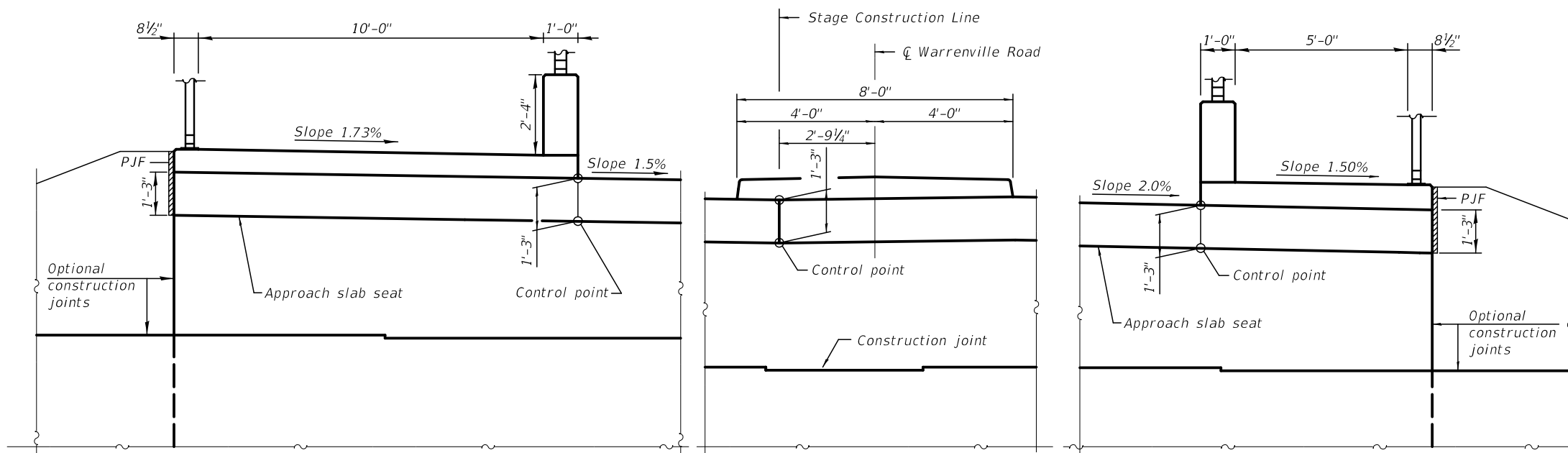

VIEW B-B

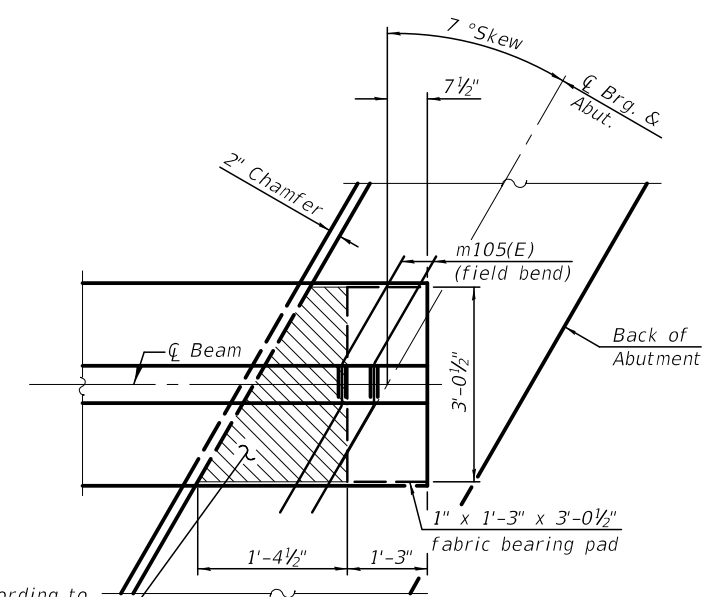

PLAN AT ABUTMENT
(Showing bottom flange of beam)

Cellular polystyrene according to ASTM C 578 (Types V, VII or XV). Provide slightly thicker piece than measured gap height to tightly fill the hatched area shown between abutment cap and bottom of beam.

Notes:
See sheet S-18 for superstructure details and Bill of Material. See sheet S-18 for P.J.F. details.
The s100(E), s101(E) and s102(E) bars shall be placed parallel to the beams. Spacing for these bars shall be at right angles to the beams.
The approach slab seat shall have a constant slope determined from the control points shown.
Cost of cellular polystyrene is included with Concrete Superstructure.

PLOT DATE = 2/9/2024

DIA-IL36-L

6-15-2019



DESIGNED - FJW	REVIS
CHECKED - LAS	REVIS
SCALE - NONE	REVIS
DATE - 2/9/2024	REVIS

DRAWN - DJC	REVIS
CHECKED - LAS	REVIS

STATE OF ILLINOIS
DEPARTMENT OF TRANSPORTATION

DIAPHRAGM DETAILS
STRUCTURE NUMBER 022-3055

SHEET S-17 OF 36 SHEETS

F.A.U. RTE.	SECTION	COUNTY	TOTAL SHEETS	SHEET NO.
1479	14-00124-00-BR	DUPAGE	208	135
CONTRACT NO. 61J14				

ILLINOIS FED. AID PROJECT

BILL OF MATERIAL

BAR	NO.	SIZE	LENGTH	SHAPE
a100(E)	290	#5	40'-0"	▬
a101(E)	290	#5	44'-6"	▬
a102(E)	32	#5	1'-6"	▬
a103(E)	4	#5	40'-3"	▬
a104(E)	4	#5	44'-10"	▬
b100(E)	476	#5	28'-3"	▬
b101(E)	370	#5	23'-4"	▬
c100(E)	208	#5	1'-4"	└
c101(E)	104	#5	7'-8"	▬
c102(E)	105	#5	11'-8"	▬
c103(E)	105	#5	6'-4"	▬
d100(E)	208	#4	4'-3"	└
d101(E)	208	#5	2'-0"	└
d102(E)	56	#4	2'-6"	└
d103(E)	56	#4	2'-2"	└
d104(E)	208	#6	4'-3"	└
e100(E)	24	#4	17'-0"	▬
e101(E)	48	#4	16'-8"	▬
m100(E)	8	#6	40'-5"	▬
m101(E)	52	#6	4'-2"	▬
m102(E)	8	#6	1'-6"	▬
m103(E)	26	#6	2'-4"	▬
m104(E)	4	#6	0'-7"	▬
m105(E)	60	#6	4'-0"	▬
m106(E)	8	#6	45'-0"	▬
s100(E)	92	#5	9'-2"	▬
s101(E)	92	#5	10'-6"	▬
s102(E)	120	#4	8'-0"	▬
v100(E)	172	#5	3'-1"	└
Concrete Superstructure			Cu. Yd.	434.1
Bridge Deck Grooving			Sq. Yd.	628
Reinforcement Bars, Epoxy Coated			Pound	60,330
Bar Splicers			Each	304
Name Plates			Each	1
Protective Coat			Sq. Yd.	1108
Floor Drain			Each	4

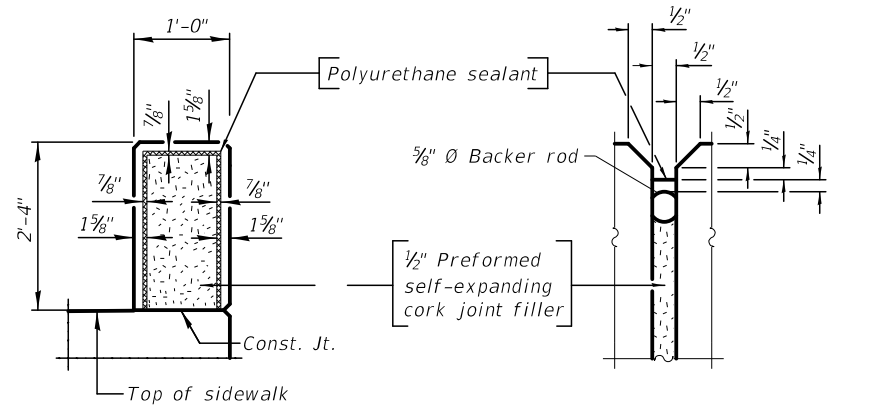

SHARED USE PATH & SIDEWALK PARAPET JOINT DETAILS

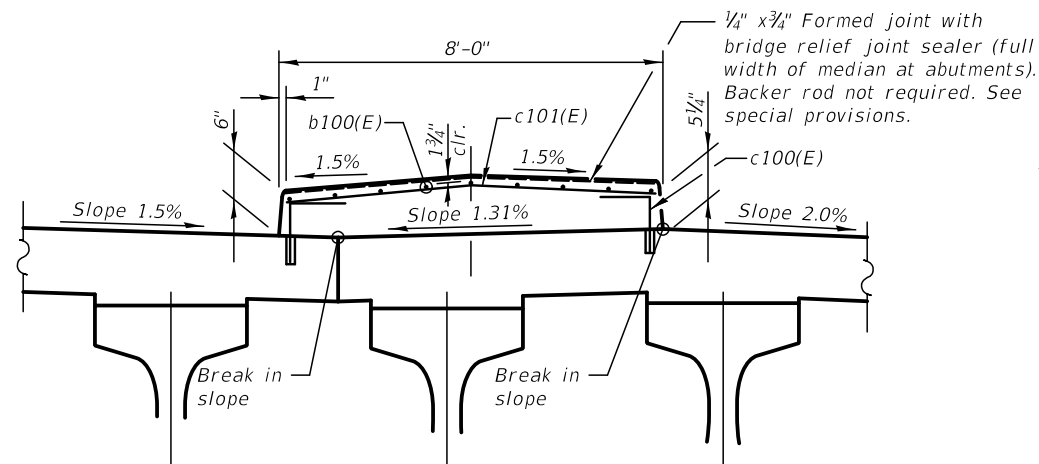

SECTION THROUGH MEDIAN

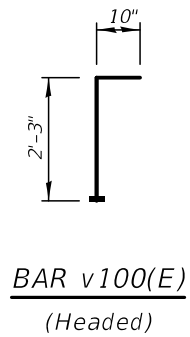

BAR v100(E) (Headed)

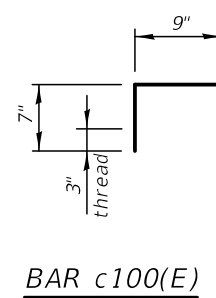

BAR c100(E)

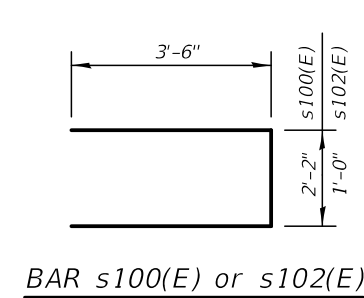

BAR s100(E) or s102(E)

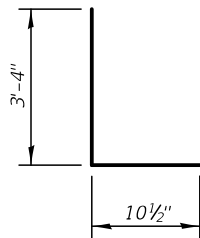

BARS d100(E) & d104(E)

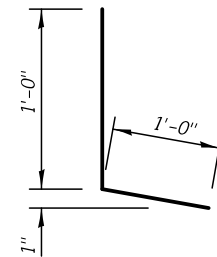

BAR d101(E)

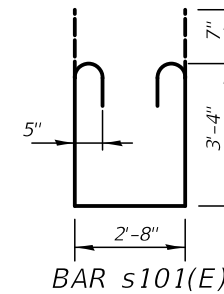

BAR s101(E)

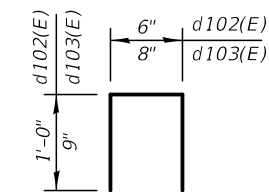

BARS d102(E) & d103(E)

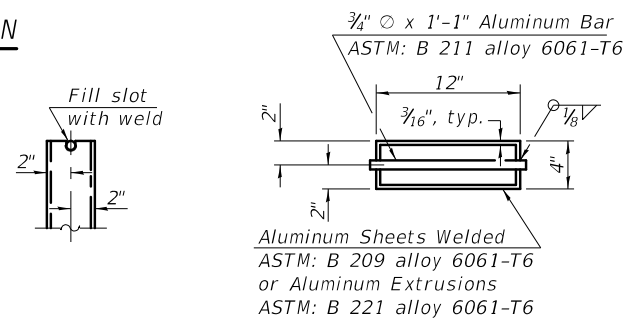

TOP PLAN

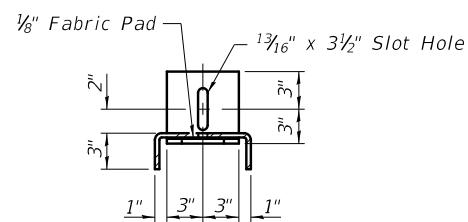

SECTION B-B

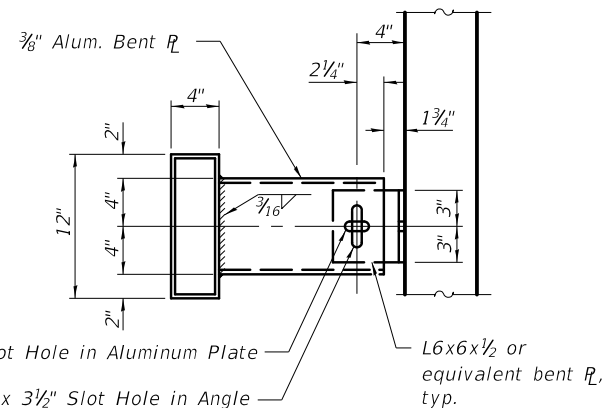

SECTION A-A

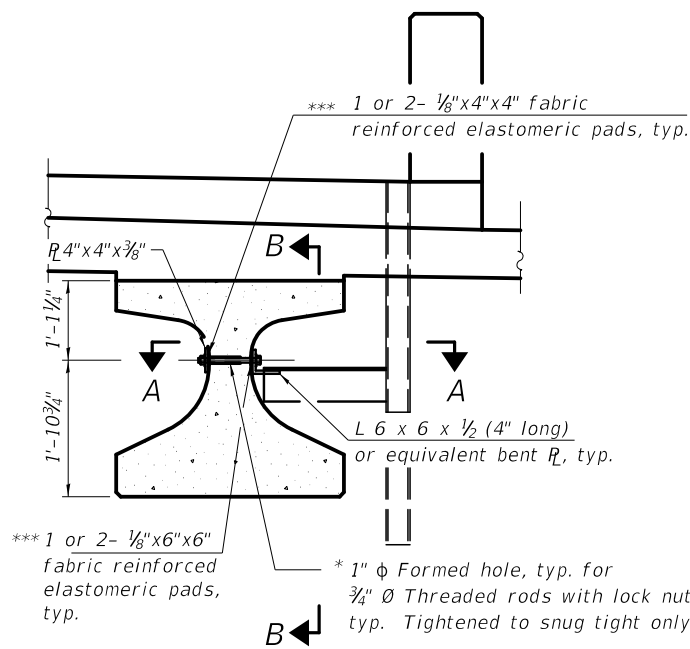

FLOOR DRAIN SUPPORT

*** Place pads as necessary to provide a flat mounting surface between the steel and concrete.

Notes:
The exterior surfaces of the floor drains shall be coated or pigmented by the manufacturer with a color that matches the concrete.
Two hardened washers are required for each set of oversized holes. All holes shall be 1 3/16" Ø unless otherwise noted.
3/16" x 3" x 3" plate washers are required over all slotted holes.
Threaded rods shall be ASTM F 1554 Grade 55.

Notes:
The top portion of aluminum floor drains shall be coated to minimize reaction with wet concrete.
The polyurethane sealant shall be according to Article 1050.04 of the Std. Spec. and the color shall be gray.
Headed bars shall conform to ASTM A970 with threaded attachment; Class HA; and reinforcement bars conforming to ASTM A706. Cost included with Reinforcement Bars, Epoxy Coated.

PLOT DATE = 2/9/2024



DESIGNED	-	FJW	REVISED				
CHECKED	-	LAS	REVISED				
SCALE	-	NONE	DRAWN	-	DJC	REVISED	
DATE	-	2/9/2024	CHECKED	-	LAS	REVISED	

DESIGNED	-	FJW	REVISED	
CHECKED	-	LAS	REVISED	
DRAWN	-	DJC	REVISED	
CHECKED	-	LAS	REVISED	

STATE OF ILLINOIS
DEPARTMENT OF TRANSPORTATION

DECK MISCELLANEOUS DETAILS
STRUCTURE NUMBER 022-3055

SHEET S-18 OF 36 SHEETS

F.A.U. RTE.	SECTION	COUNTY	TOTAL SHEETS	SHEET NO.
1479	14-00124-00-BR	DUPAGE	208	136
			CONTRACT NO. 61J14	
ILLINOIS FED. AID PROJECT				

PLOT DATE = 2/9/2024

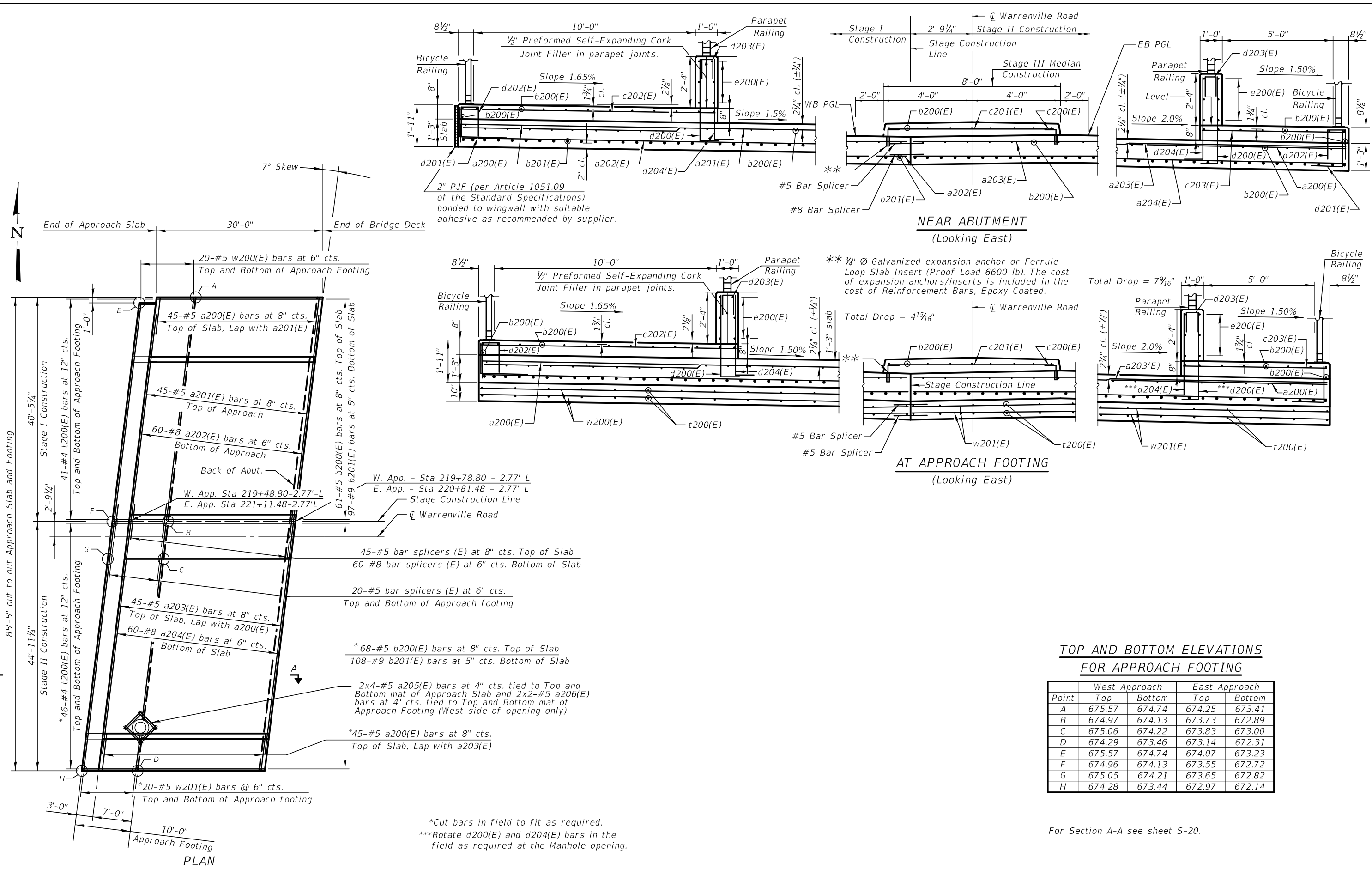

DESIGNED - FJW
 CHECKED - LAS
 SCALE - NONE
 DATE - 2/9/2024

REVISOR - FJW
 REVISION - LAS
 DRAWN - DJC
 CHECKED - LAS

STATE OF ILLINOIS
 DEPARTMENT OF TRANSPORTATION

BRIDGE APPROACH SLAB PLAN
 STRUCTURE NUMBER 022-3055
 SHEET S-19 OF 36 SHEETS

F.A.U. RTE. 1479
 SECTION 14-00124-00-BR
 COUNTY DUPAGE
 TOTAL SHEETS 208
 SHEET NO. 137
 CONTRACT NO. 61J14
 ILLINOIS FED. AID PROJECT

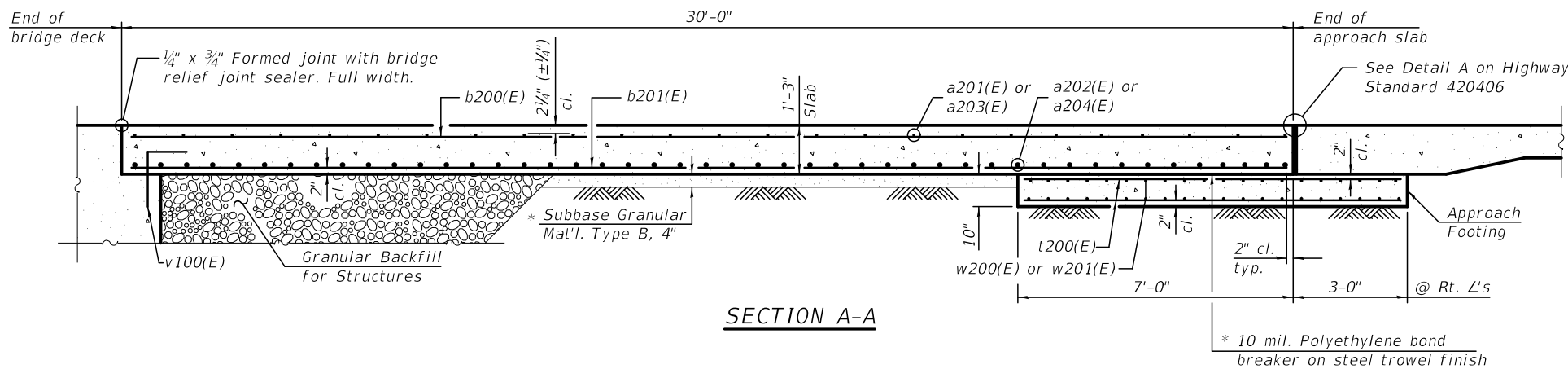

SECTION A-A

Notes:
 The joint opening shall be adjusted for temperature per Article 520.04 of the Standard Specifications. However, since this detail is for jointless structures, the length of bridge used to calculate the adjustment shall be equal to half the total bridge length plus the length of the bridge approach slab.
 Parapet, sidewalk, median, and multi-use path concrete shall be paid for as Concrete Superstructure.
 Approach slab shall be paid for as Concrete Superstructure (Approach Slab).
 Approach footing concrete shall be paid for as Concrete Structures.
 The approach footing maximum applied service bearing pressure (Qmax) = 2.0 ksf.
 Cost of excavation for approach footing included with Concrete Structures.
 For Granular Backfill for Structures and drainage treatment details, see sheet S-2.

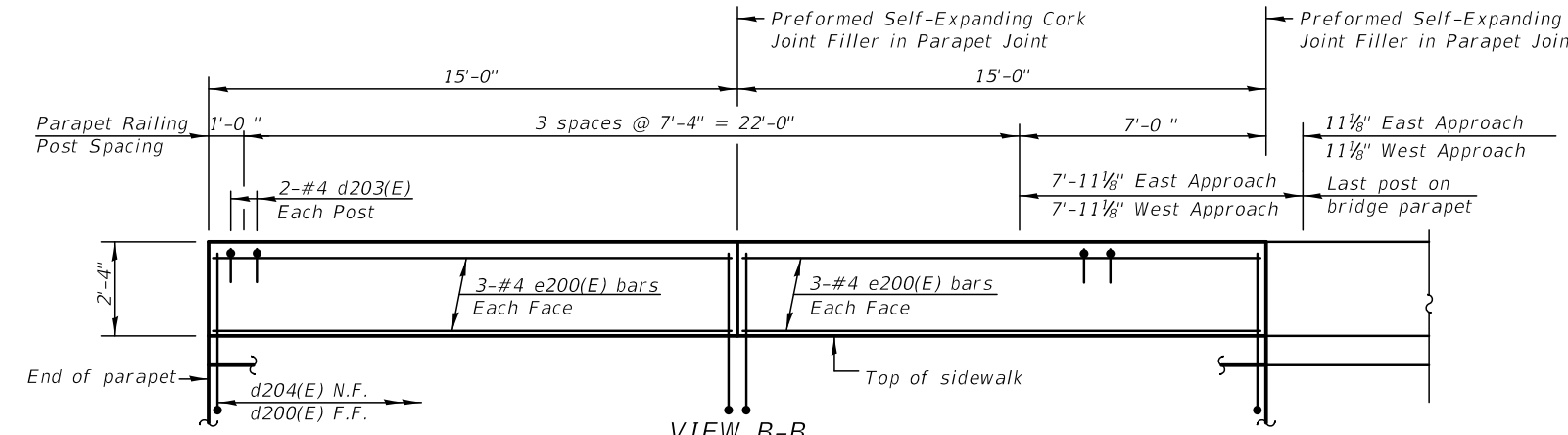
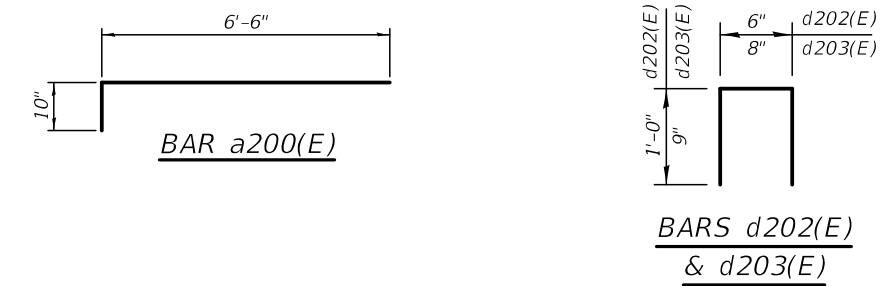

VIEW B-B

Dimensions along roadway face of parapet
 East Approach parapet shown, West Approach parapet opposite hand

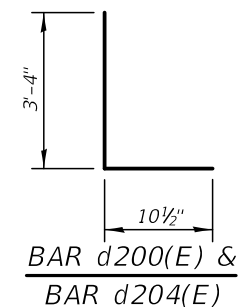
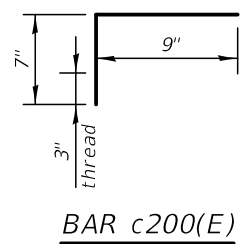

TWO APPROACHES
 BILL OF MATERIAL

Bar	No.	Size	Length	Shape
a200(E)	180	#5	7'-4"	┌
a201(E)	90	#5	40'-3"	—
a202(E)	120	#8	40'-3"	—
a203(E)	90	#5	45'-0"	—
a204(E)	120	#8	45'-0"	—
a205(E)	16	#5	4'-6"	—
a206(E)	8	#5	3'-10"	—
b200(E)	322	#5	29'-8"	—
b201(E)	410	#9	29'-8"	—
c200(E)	124	#5	1'-4"	┌
c201(E)	62	#5	7'-8"	—
c202(E)	62	#5	11'-4"	—
c203(E)	62	#5	6'-4"	—
d200(E)	120	#4	4'-3"	┌
d201(E)	120	#4	2'-0"	┌
d202(E)	40	#4	2'-6"	┌
d203(E)	32	#4	2'-2"	┌
d204(E)	120	#6	4'-3"	┌
e200(E)	48	#4	14'-8"	—
t200(E)	348	#4	9'-8"	—
w200(E)	80	#5	40'-3"	—
w201(E)	80	#5	45'-0"	—
Concrete Superstructure			Cu. Yd.	287.8
Concrete Superstructure (Approach Slab)			Cu. Yd.	237.4
Concrete Structures			Cu. Yd.	52.8
Bridge Deck Grooving			Sq. Yd.	367
Protective Coat			Sq. Yd.	644
Bar Splicers			Each	290
Reinforcement Bars, Epoxy Coated			Pound	101,140

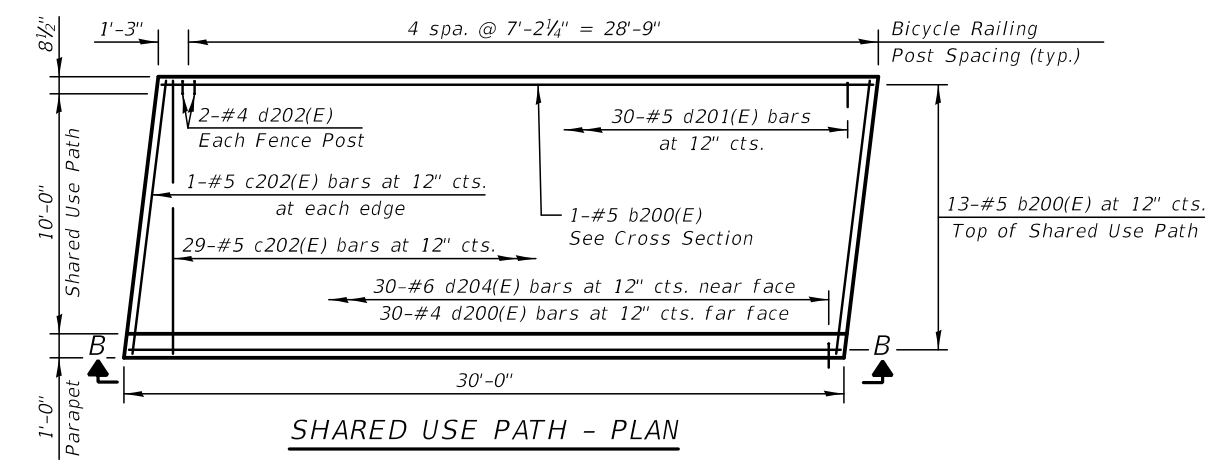

SHARED USE PATH - PLAN

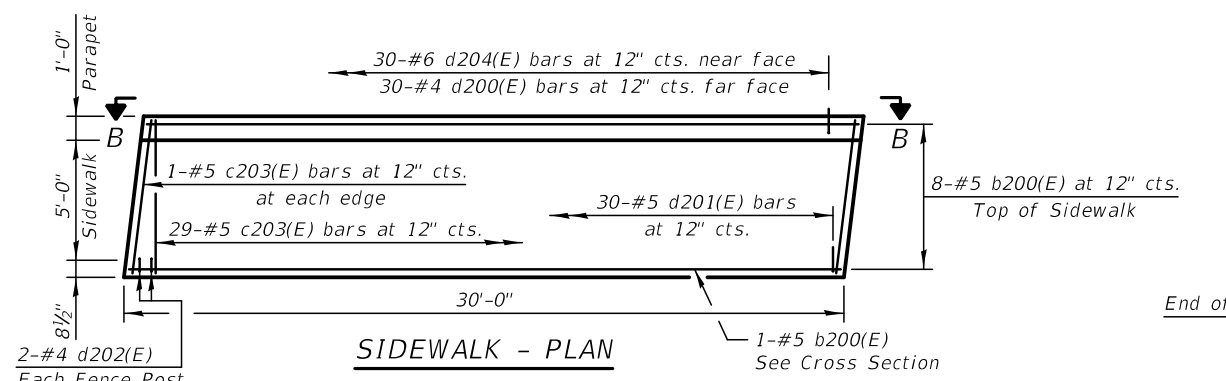

SIDEWALK - PLAN

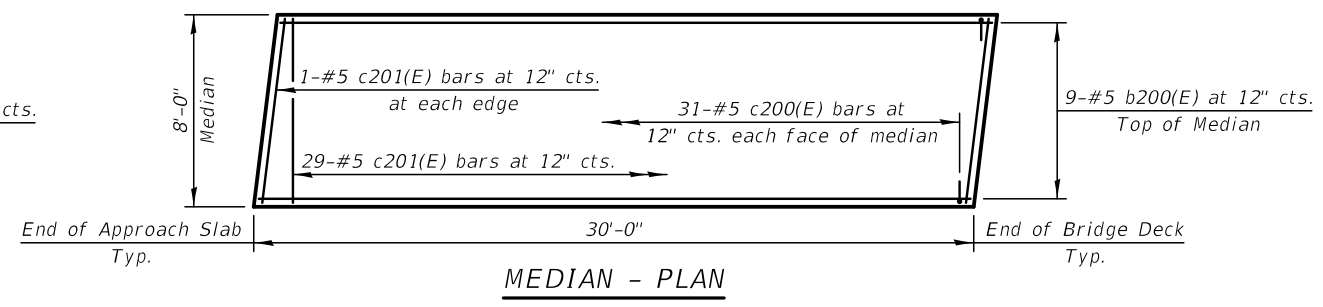

MEDIAN - PLAN

PLOT DATE = 2/9/2024



DESIGNED - FJW	REVISIONS
CHECKED - LAS	REVISIONS
DRAWN - DJC	REVISIONS
CHECKED - LAS	REVISIONS

STATE OF ILLINOIS
 DEPARTMENT OF TRANSPORTATION

BRIDGE APPROACH SLAB DETAILS
 STRUCTURE NUMBER 022-3055

SHEET S-20 OF 36 SHEETS

F.A.U. RTE.	SECTION	COUNTY	TOTAL SHEETS	SHEET NO.
1479	14-00124-00-BR	DUPAGE	208	138
CONTRACT NO. 61J14				

ILLINOIS FED. AID PROJECT

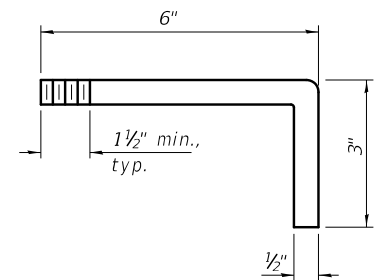
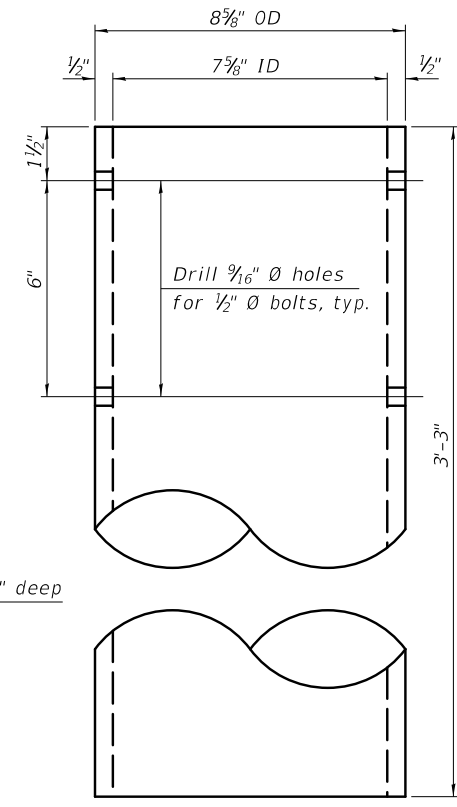
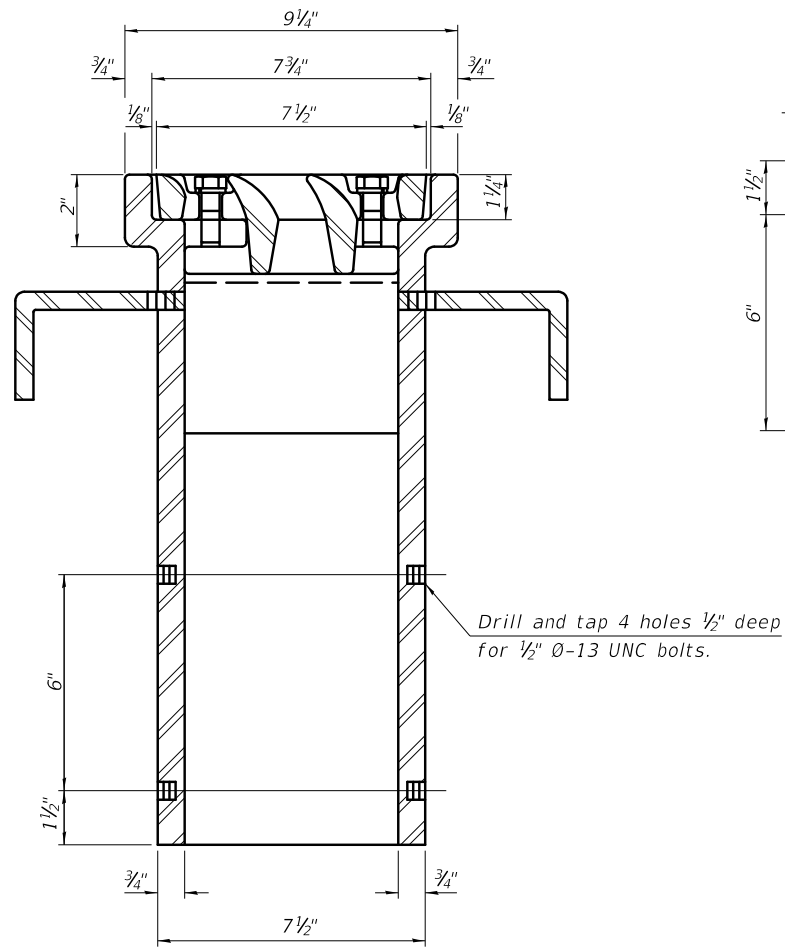
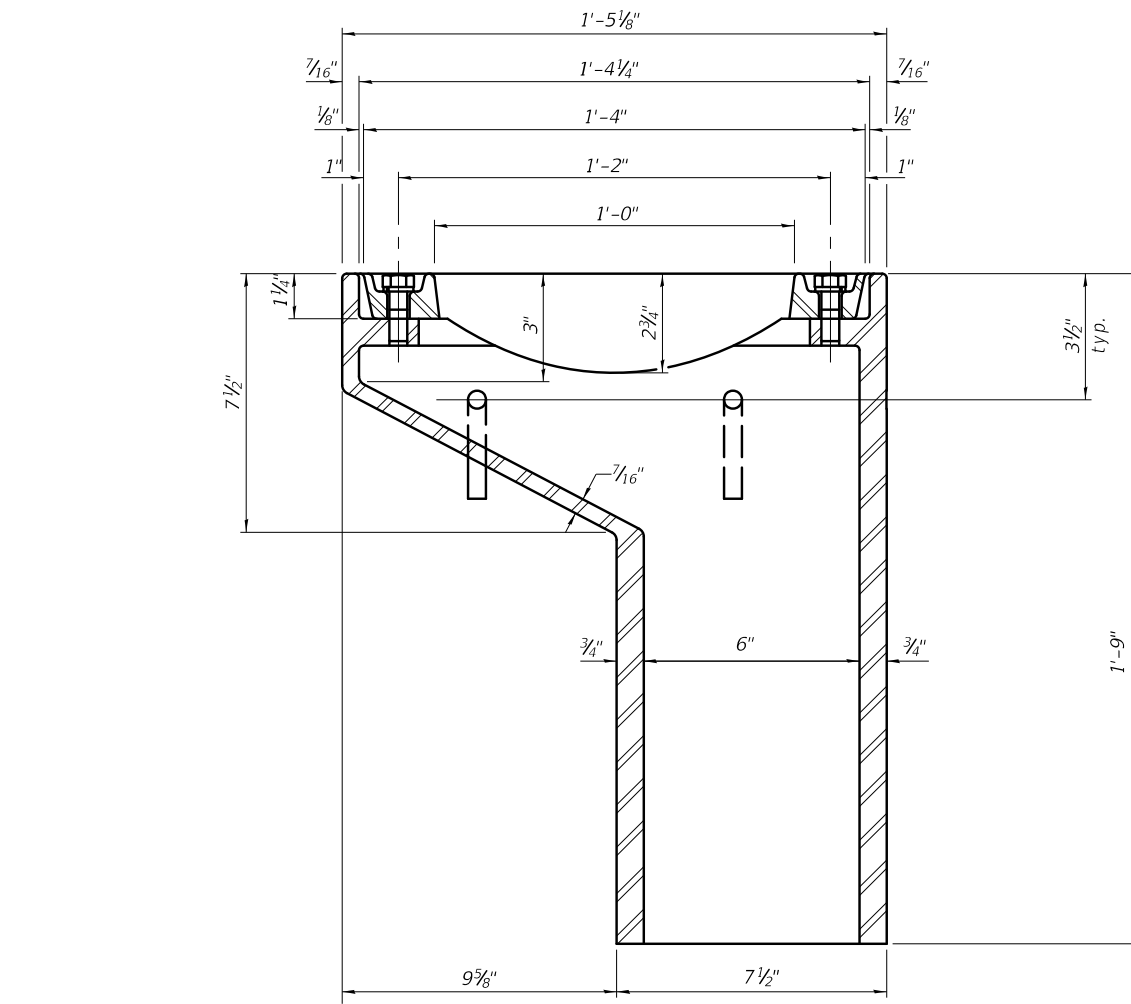
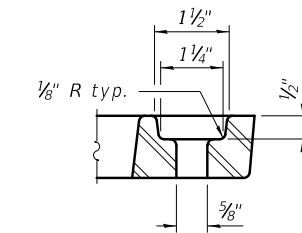
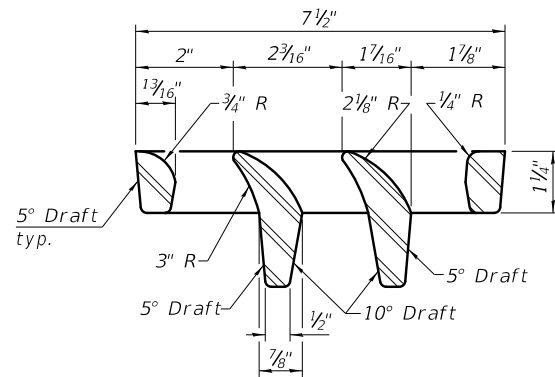
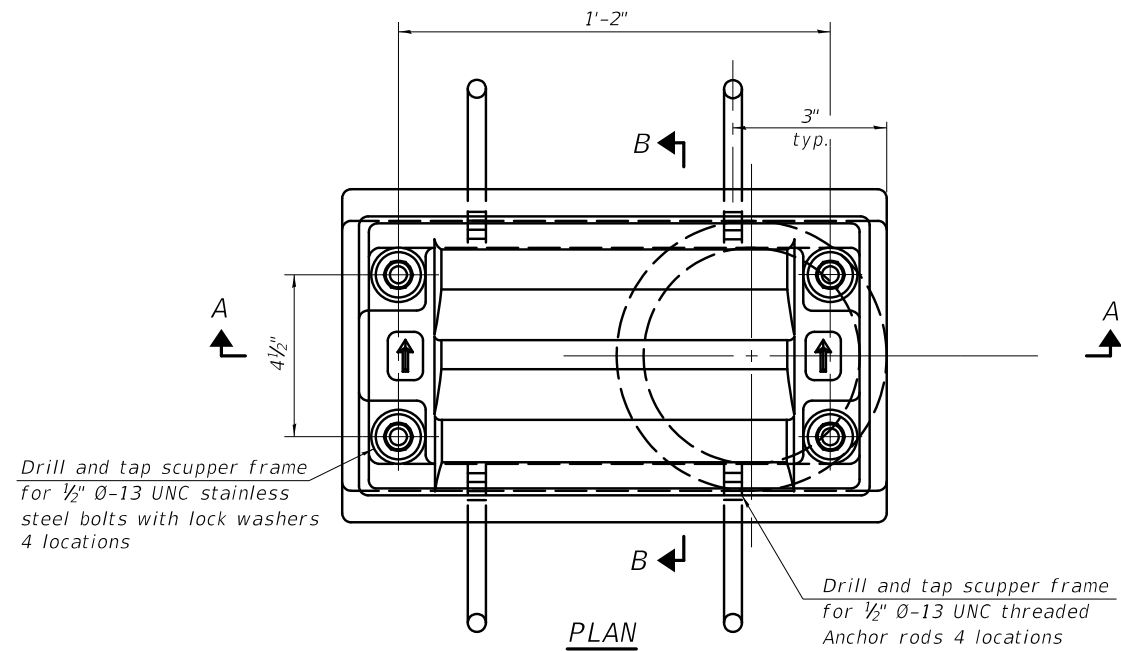

BILL OF MATERIAL

ITEM	UNIT	QUANTITY
Drainage Scupper, DS-11	Each	4

Notes:

All cast iron parts shall be gray iron conforming to the requirements of AASHTO M105, Class 35B and AASHTO M306.

Bolts, anchor rods, nuts and washers shall be according to ASTM A307 and shall be galvanized according to AASHTO M232. As an alternate stainless steel may be used.

Stainless steel hardware shall be according to Article 1006.29(d) of the Standard Specifications.

Structural steel weldments of equal sections and of the same configuration may be substituted for the cast iron scupper frames and downspouts; however, the scupper grates shall remain cast iron. Fillet or full penetration welds shall be used for the weldments. Details shall be submitted to the Engineer for approval.

Structural steel scupper frames and downspouts, when utilized, shall be galvanized according to AASHTO M111.

As an alternate, fiberglass may be used for downspouts according to ASTM D2996 with a short-time rupture strength hoop tensile stress of 30,000 psi min. in lieu of the cast iron or structural steel.

Exterior surfaces of downspouts and exterior exposed surfaces of the scupper frame below deck shall be treated as specified on sheet S-18 of S-36.

The Contractor shall take appropriate measures to assure that Protective Coat is not applied to the scupper.

Cost of the grate, frame, downspout, anchor rods, nuts and washers including complete installation of the scupper shall be paid for at the contract unit price for Drainage Scupper, DS-11.

DS-11

1-1-2020



DESIGNED - FJW	REVISED
CHECKED - LAS	REVISED
DRAWN - DJC	REVISED
CHECKED - LAS	REVISED

STATE OF ILLINOIS
DEPARTMENT OF TRANSPORTATION

DRAINAGE SCUPPER, DS-11
STRUCTURE NUMBER 022-3055

F.A.U. RTE.	SECTION	COUNTY	TOTAL SHEETS	SHEET NO.
1479	14-00124-00-BR	DUPAGE	208	139
CONTRACT NO. 61J14				

SHEET S-21 OF 36 SHEETS

ILLINOIS FED. AID PROJECT

PLOT DATE = 2/9/2024

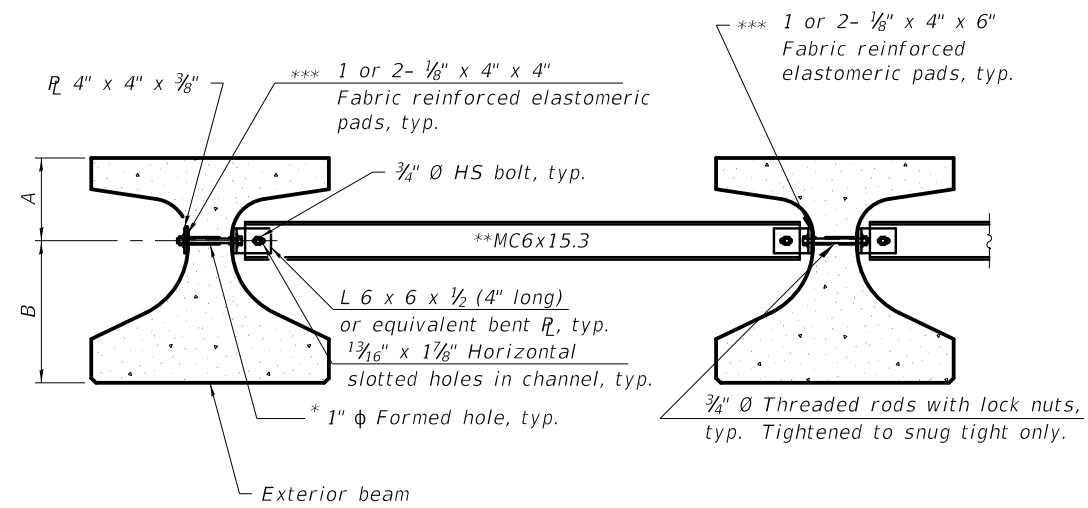

Notes:
 All material for bracing shall be hot dip galvanized according to AASHTO M111 unless otherwise noted.
 Two hardened washers are required for each set of oversized holes.
 All holes shall be 1 5/16" Ø unless otherwise noted.
 5/16" x 3" x 3" plate washers are required over all slotted holes.
 All bolts, threaded rods, and hardware shall be galvanized according to AASHTO M232.
 Threaded rods shall be ASTM F 1554 Grade 55.
 Bracing shall be installed as beams are erected and tightened as soon as possible during erection.
 Permanent bracing shall not be paid for separately, but shall be included in the cost of Furnishing and Erecting Precast Prestressed Concrete Beams.

Beam	A	B
IL27	11 1/4"	1'-3 3/4"
IL36	1'-1 1/4"	1'-10 3/4"

- * Fabricator shall locate to miss strands within permissible tolerances.
- ** Alternate MC6x18 channels are permitted to facilitate material acquisition.
- *** Place pads as necessary to provide a flat mounting surface between the steel and concrete.

PERMANENT BRACING DETAILS FOR IL27 AND IL36 BEAMS

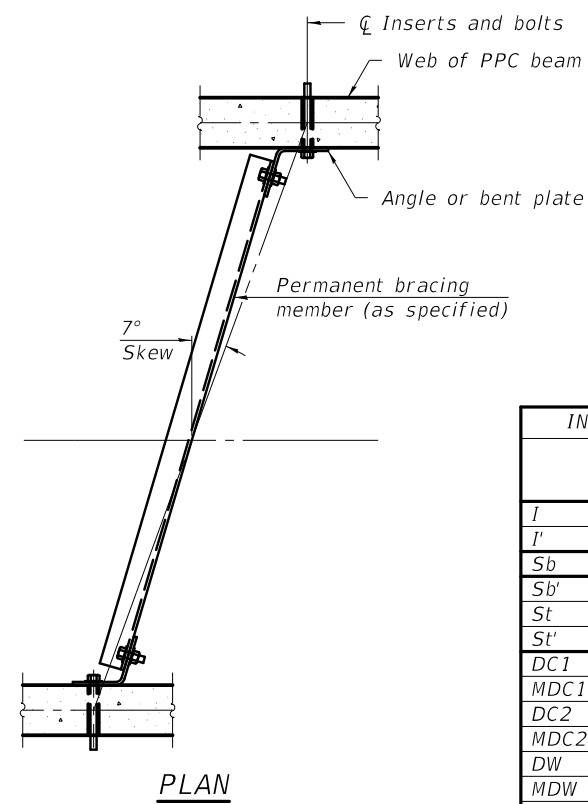

INTERIOR BEAM MOMENT TABLE		
0.5 Sp. 1		
I	(in ⁴)	124,639
I'	(in ⁴)	282,114
S _b	(in ³)	7,563
S _b '	(in ³)	11,435.5
S _t	(in ³)	6385.1
S _t '	(in ³)	24,899.7
DC1	(k/')	1.419
MDC1	('k)	1800.1
DC2	(k/')	0.202
MDC2	('k)	256.6
DW	(k/')	0.223
MDW	('k)	283.2
M _L + IM	('k)	1439.6

INTERIOR BEAM REACTION TABLE		
Abut.		
RDC1	(k)	71.5
RDC2	(k)	10.2
RDW	(k)	11.3
R _L + IM	(k)	78.3
RTotal	(k)	171.3

- I: Non-composite moment of inertia of beam section (in.⁴).
- I': Composite moment of inertia of beam section (in.⁴).
- S_b: Non-composite section modulus for the bottom fiber of the prestressed beam (in.³).
- S_b': Composite section modulus for the bottom fiber of the prestressed beam (in.³).
- S_t: Non-composite section modulus for the top fiber of the prestressed beam (in.³).
- S_t': Composite section modulus for the top fiber of the prestressed beam (in.³).
- DC1: Un-factored non-composite dead load (kips/ft.).
- MDC1: Un-factored moment due to non-composite dead load (kip-ft.).

- DC2: Un-factored long-term composite (superimposed excluding future wearing surface) dead load (kips/ft.).
- MDC2: Un-factored moment due to long-term composite (superimposed excluding future wearing surface) dead load (kip-ft.).
- DW: Un-factored long-term composite (superimposed future wearing surface only) dead load (kips/ft.).
- MDW: Un-factored moment due to long-term composite (superimposed future wearing surface only) dead load (kip-ft.).
- M_L + IM: Un-factored live load moment plus dynamic load allowance (impact) (kip-ft.).

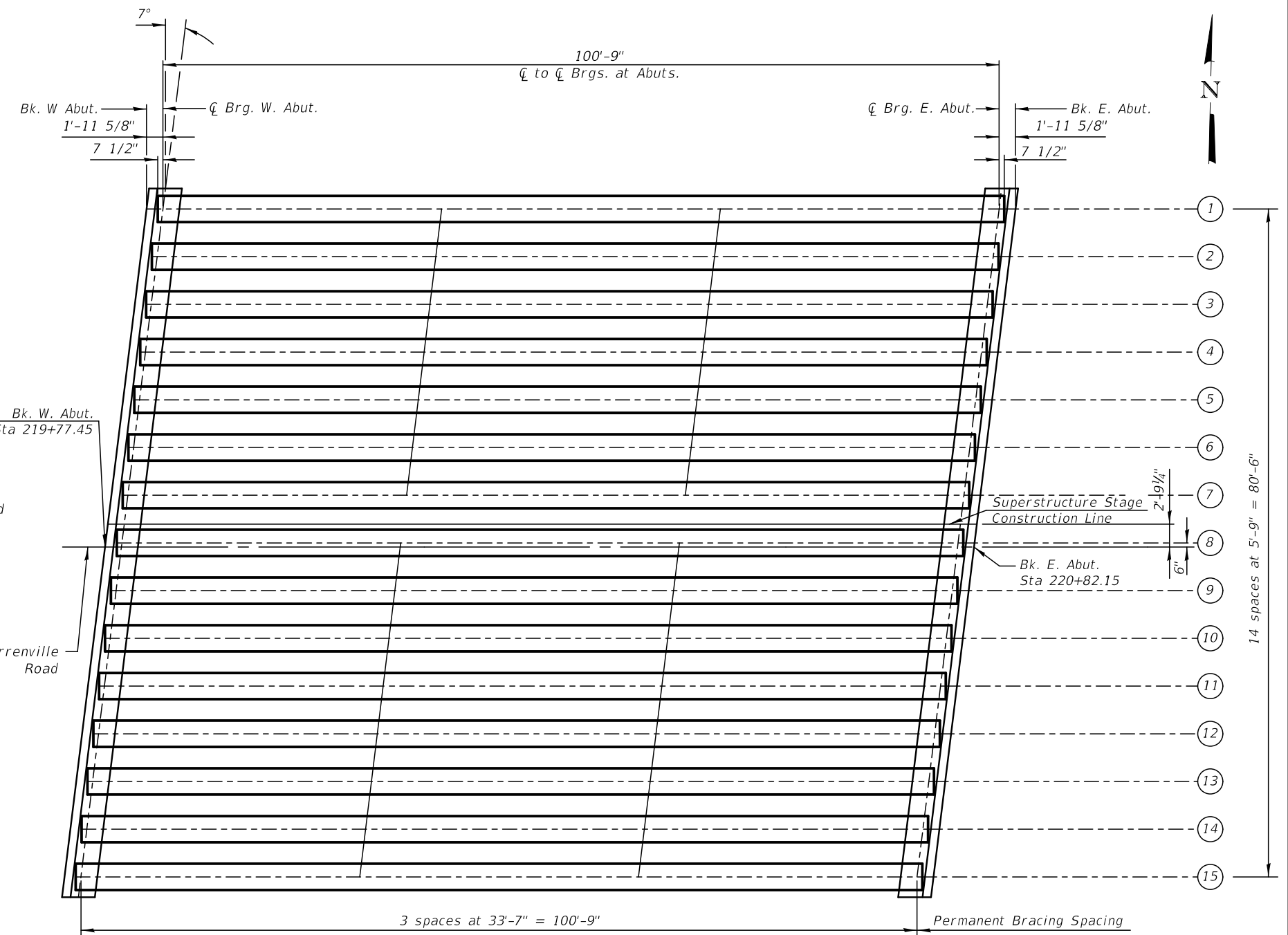

PLOT DATE = 2/9/2024



DESIGNED - FJW	REVISED
CHECKED - LAS	REVISED
DRAWN - DJC	REVISED
CHECKED - LAS	REVISED

STATE OF ILLINOIS
 DEPARTMENT OF TRANSPORTATION

FRAMING PLAN & PERMANENT BRACING DETAILS
 STRUCTURE NUMBER 022-3055

F.A.U. RTE.	SECTION	COUNTY	TOTAL SHEETS	SHEET NO.
1479	14-00124-00-BR	DUPAGE	208	140
CONTRACT NO. 61J14				

SHEET S-22 OF 36 SHEETS

ILLINOIS FED. AID PROJECT

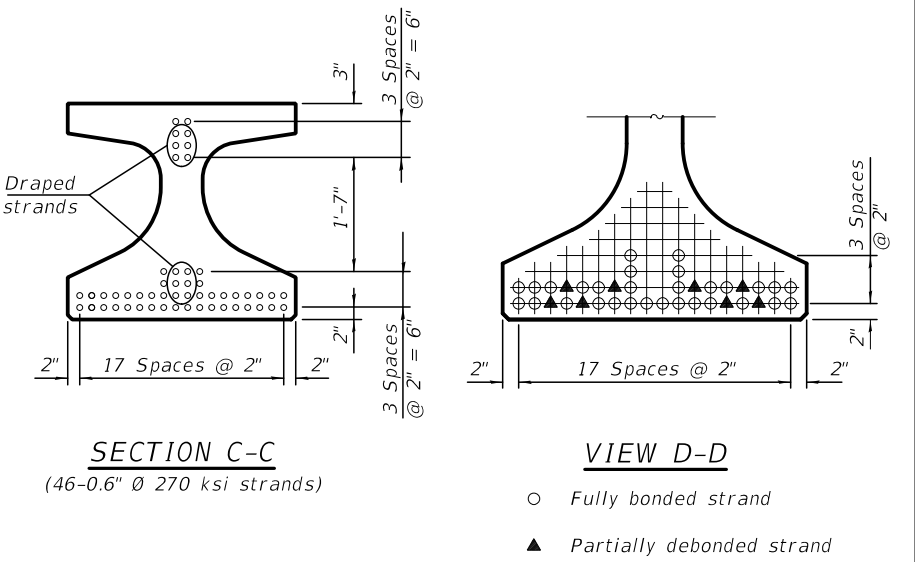
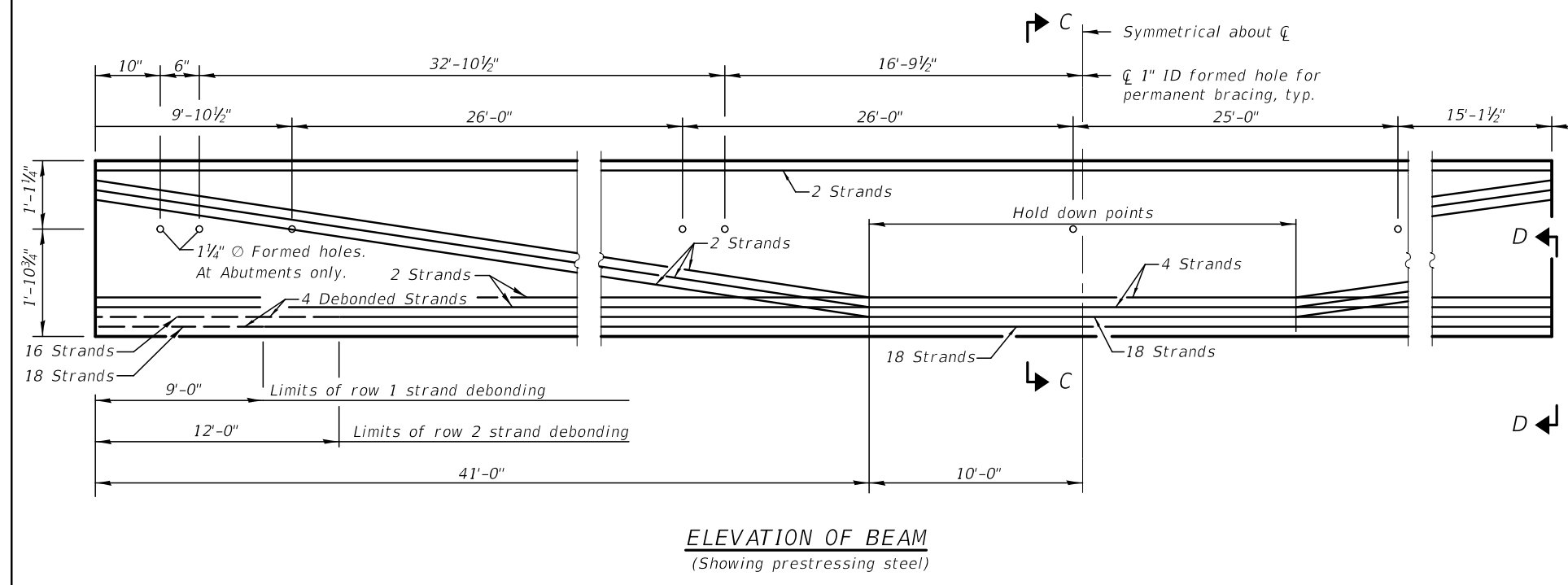
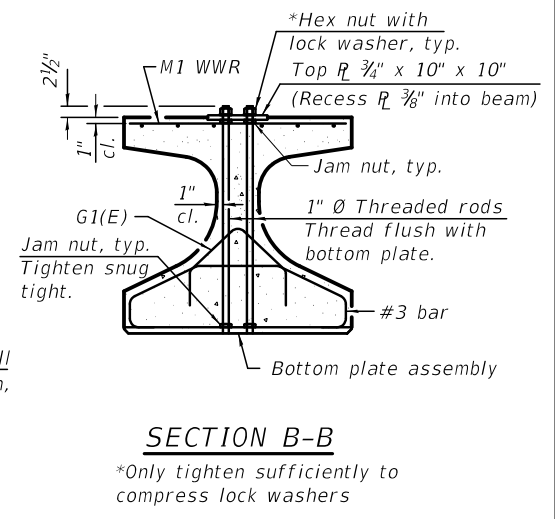
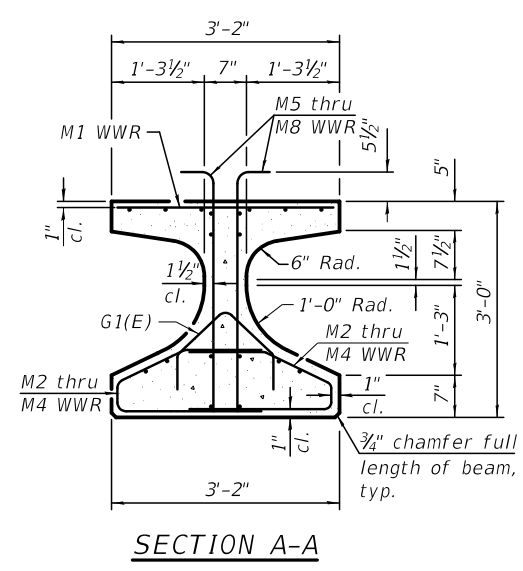
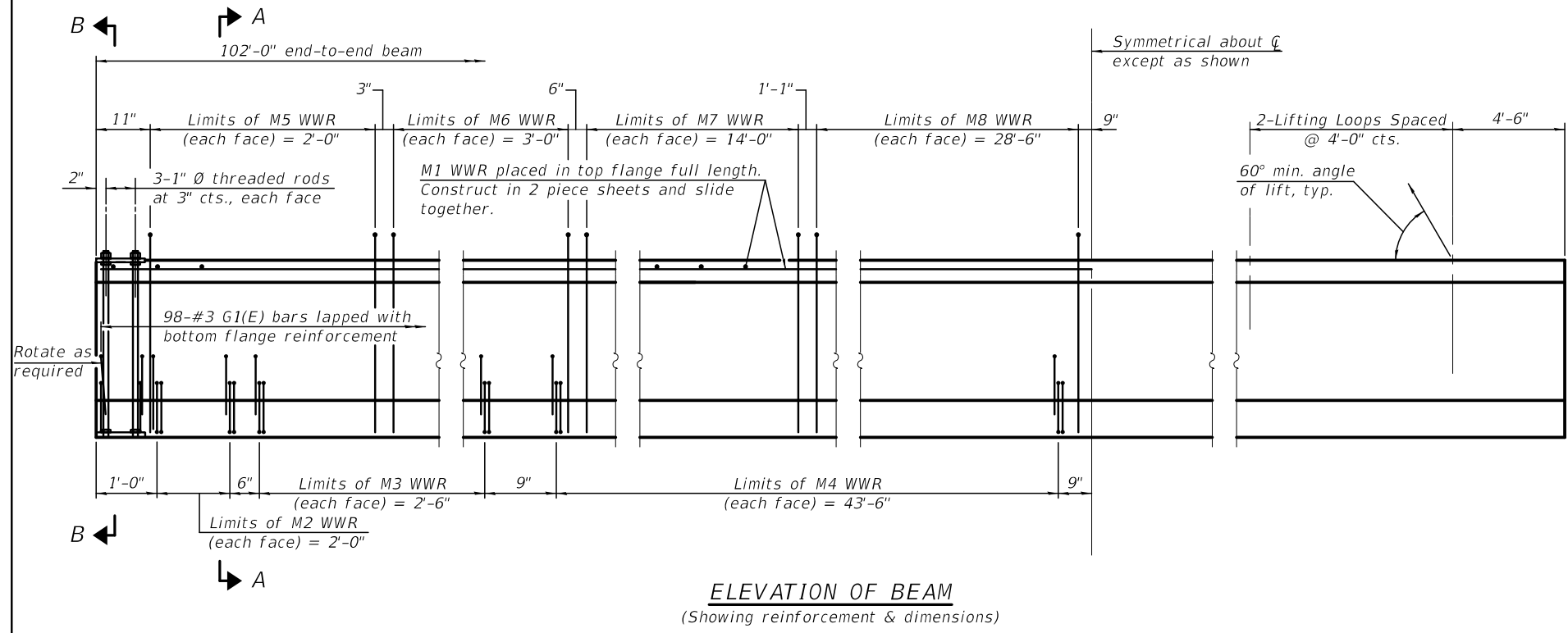

Notes:
See sheet S-24 for additional details and Bill of Material.
Fabricator shall locate formed holes to miss strands within permissible tolerances for floor drain connections

IL36-3838
2-25-2019
KNIGHT
Member of WSP

DESIGNED - FJW	REVIS
CHECKED - LAS	REVIS
DRAWN - DJC	REVIS
CHECKED - LAS	REVIS
SCALE - NONE	
DATE - 2/9/2024	

STATE OF ILLINOIS
DEPARTMENT OF TRANSPORTATION

IL36 BEAM
STRUCTURE NUMBER 022-3055
SHEET S-23 OF 36 SHEETS

F.A.U. RTE.	SECTION	COUNTY	TOTAL SHEETS	SHEET NO.
1479	14-00124-00-BR	DUPAGE	208	141
CONTRACT NO. 61J14				

ILLINOIS FED. AID PROJECT

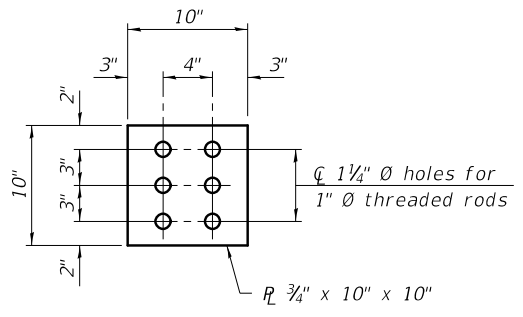

PLAN - TOP PLATE

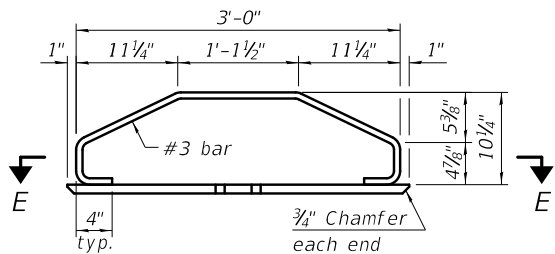

ELEVATION - BOTTOM PLATE ASSEMBLY

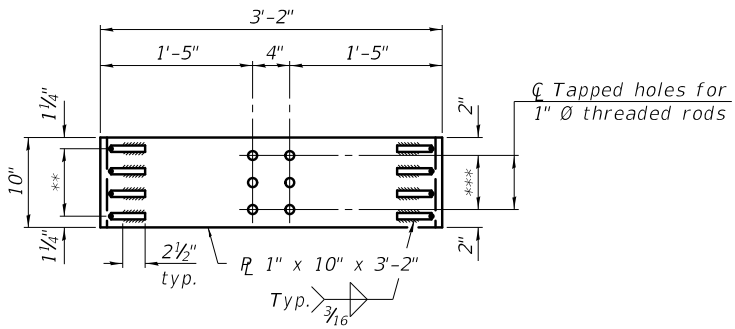

SECTION E-E

** 3 Spaces at 2 1/2" = 7 1/2"
 *** 2 Spaces at 3" = 6"

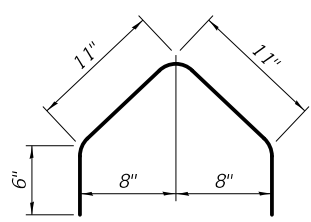

BAR G1(E)

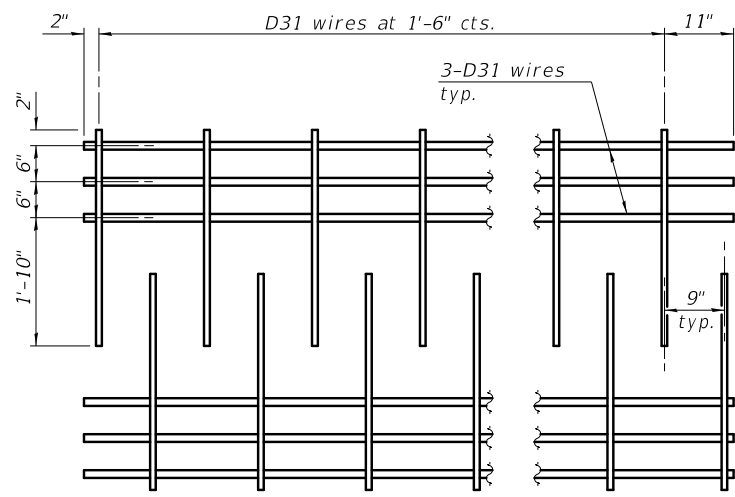

M1 WWR DETAIL

When multiple sheets of M1 WWR are required along the beam length, #5(E) bars (5'-0" long) shall be used to splice the longitudinal D31 wires together (Min. Lap 2'-2").

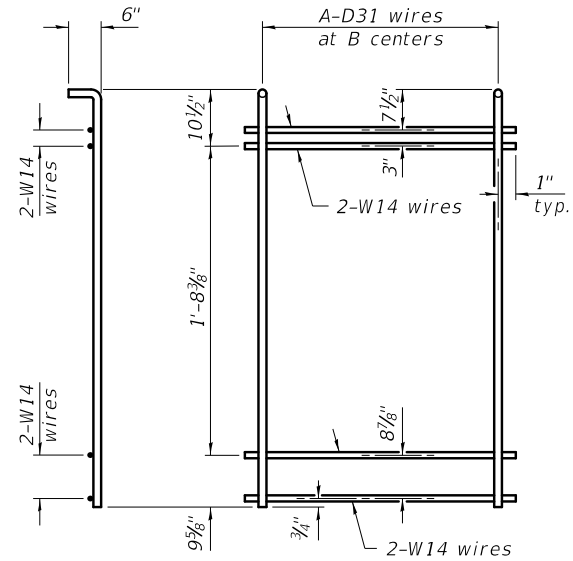

M5 THRU M8 WWR DETAIL

(See Table of Dimensions)

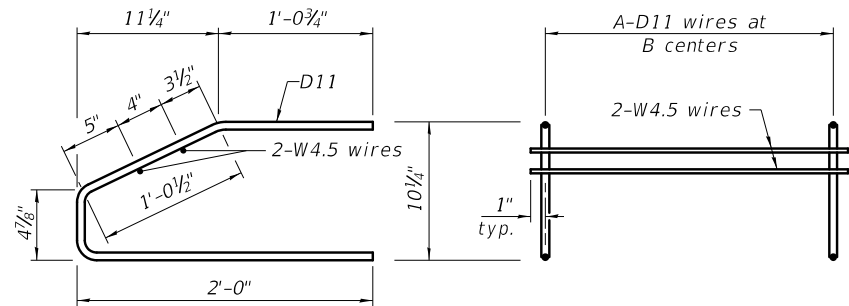

M2 THRU M4 WWR DETAIL

(See Table of Dimensions)

TABLE OF DIMENSIONS

SPAN 1		
WWR	A	B
M2	9	3"
M3	6	6"
M4	30	1'-6"
M5	9	3"
M6	7	6"
M7	15	1'-0"
M8	20	1'-6"

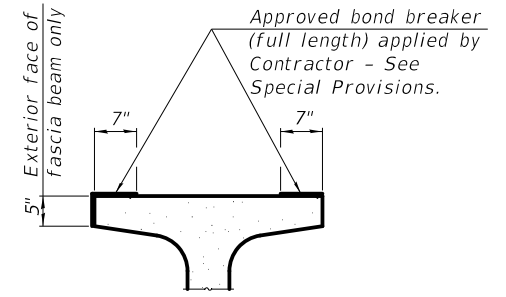

SECTION THRU TOP FLANGE

(Showing limits of bond breaker)

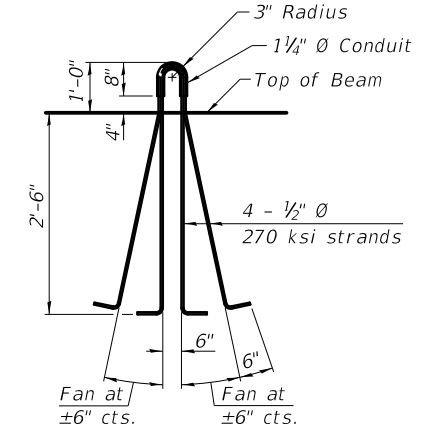

LIFTING LOOP DETAIL

BILL OF MATERIAL

Item	Unit	Total
Furnishing and Erecting Precast Prestressed Concrete Beams, IL36	Ft.	1530

NOTES

Inserts for 3/4" Ø threaded dowel rods, when specified, are to be two strut, ferrule type for interior beams and single ferrule, flared loop type for exterior beams.

Prestressing steel shall be uncoated high strength, low relaxation 7-wire strand, Grade 270. The nominal diameter for beam strands shall be 0.6" and the nominal cross-sectional area shall be 0.217 sq. in. The nominal diameter for lifting loops shall be 1/2" and the nominal cross sectional area shall be 0.153 sq. in.

The beams shall have a final concrete compressive strength, f'c, of 8500 psi and a release concrete compressive strength, f'ci, of 6500 psi.

A minimum 2 1/2" Ø lifting pin shall be used to engage the lifting loops during handling.

Bend the extended strands inward on the fascia beams to maintain 1 1/2" clearance inside the pier diaphragm.

The top and bottom plates shall be AASHTO M270 Grade 50.

The top plates and bottom plate assemblies shall be galvanized according to AASHTO M111.

The threaded rods, nuts and washers shall be galvanized according to AASHTO M232.

Threaded rods shall be ASTM F 1554 Grade 55.

Welded Wire Reinforcement (WWR) shall conform to ASTM A884 with a Class A, Type 1 epoxy coating or ASTM A1060, Table 3 galvanized coating.

PLOT DATE = 2/9/2024

IL36-3838D

8-13-2021



DESIGNED - FJW	REVIS
CHECKED - LAS	REVIS
SCALE - NONE	REVIS
DATE - 2/9/2024	REVIS

DESIGNED - FJW	REVIS
CHECKED - LAS	REVIS
DRAWN - DJC	REVIS
CHECKED - LAS	REVIS

STATE OF ILLINOIS
 DEPARTMENT OF TRANSPORTATION

IL36 BEAM DETAILS
 STRUCTURE NUMBER 022-3055
 SHEET S-24 OF 36 SHEETS

F.A.U. RTE.	SECTION	COUNTY	TOTAL SHEETS	SHEET NO.
1479	14-00124-00-BR	DUPAGE	208	142
CONTRACT NO. 61J14				
ILLINOIS FED. AID PROJECT				

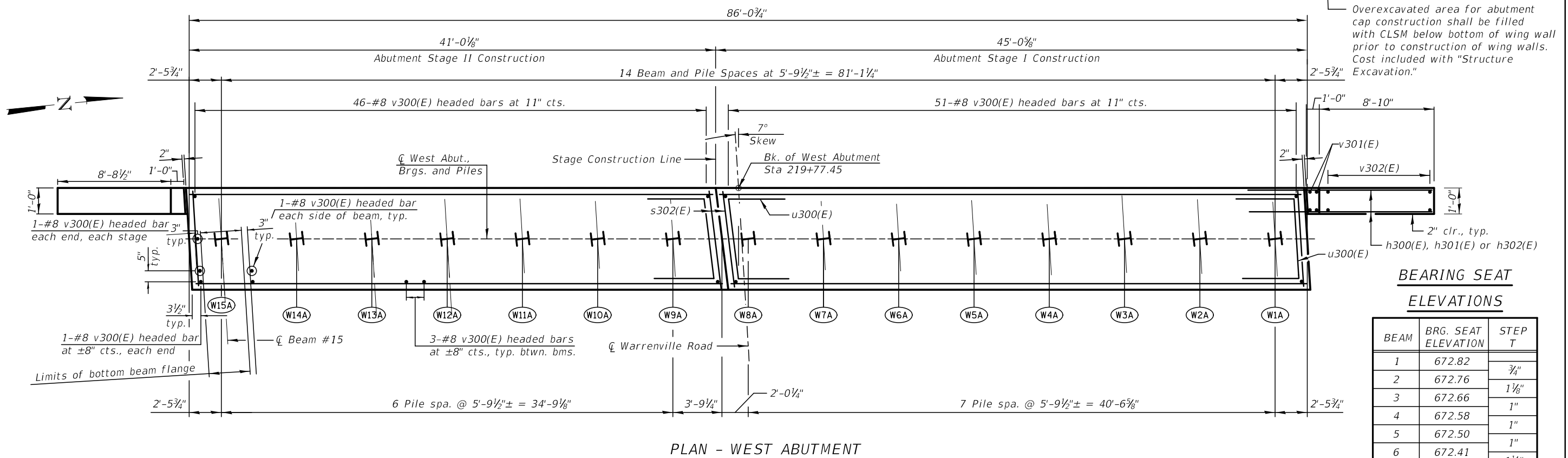
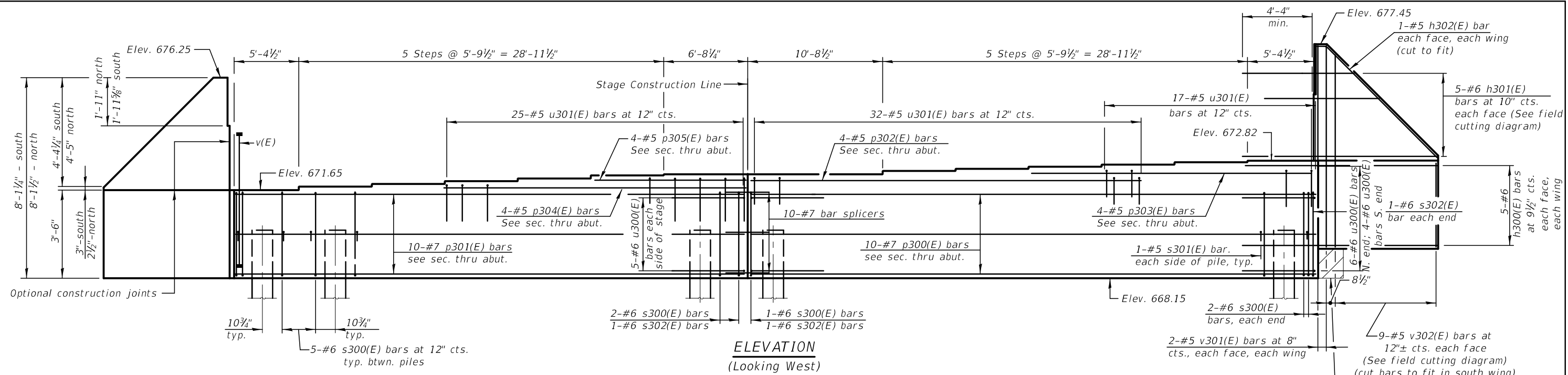

BEARING SEAT ELEVATIONS

BEAM	BRG. SEAT ELEVATION	STEP T
1	672.82	3/4"
2	672.76	1 1/8"
3	672.66	1"
4	672.58	1"
5	672.50	1"
6	672.41	1 1/4"
7	672.31	0"
8	672.31	0"
9	672.31	7/8"
10	672.24	1 1/2"
11	672.11	1 1/4"
12	672.01	1 3/8"
13	671.89	1 3/8"
14	671.78	1 5/8"
15	671.65	

- NOTES**
1. Pour steps monolithically with cap.
 2. Headed bars shall conform to ASTM A970 with threaded attachment; Class HA; and reinforcement bars conforming to ASTM A706. Cost included with Reinforcement Bars, Epoxy Coated.
 3. For details of piles see drawing S-30.
 4. See Sheet S-26 For West Abutment details.

LEGEND
 E.F. Each Face
 (W1A) Pile Number/
 Beam Line
MIN. BAR LAP
 #5 - 3'-7"
 #6 - 4'-4"
 #7 - 5'-0"

PILE DATA
 Type & Size: Steel HP 12x63
 Nominal Required Bearing: 497 Kips
 Factored Resistance Available: 273 Kips
 Est. Length: 41 ft
 No. Production Piles: 14
 No. Test Piles: 1

PLOT DATE = 2/9/2024

	DESIGNED - FJW	REVISD	STATE OF ILLINOIS DEPARTMENT OF TRANSPORTATION	WEST ABUTMENT STRUCTURE NUMBER 022-3055	F.A.U. RTE. 1479	SECTION 14-00124-00-BR	COUNTY DUPAGE	TOTAL SHEETS 208	SHEET NO. 143
	CHECKED - LAS	REVISD			CONTRACT NO. 61J14				
SCALE - NONE	DRAWN - DJC	REVISD	SHEET S-25 OF 36 SHEETS		ILLINOIS FED. AID PROJECT				
DATE - 2/9/2024	CHECKED - LAS	REVISD							

BILL OF MATERIAL

Bar	No.	Size	Length	Shape
h300(E)	20	#6	14'-2"	—
h301(E)	10	#6	19'-4"	—
h302(E)	4	#5	10'-6"	—
p300(E)	10	#7	44'-9"	—
p301(E)	10	#7	40'-9"	—
p302(E)	4	#5	31'-6"	—
p303(E)	4	#5	22'-2"	—
p304(E)	4	#5	23'-7"	—
p305(E)	4	#5	12'-2"	—
s300(E)	72	#6	14'-10"	⊞
s301(E)	30	#5	4'-7"	⊞
s302(E)	4	#6	15'-0"	⊞
u300(E)	20	#6	12'-1"	⊞
u301(E)	74	#5	6'-11"	⊞
v300(E)	177	#8	5'-6"	—
v301(E)	8	#5	7'-9"	—
v302(E)	18	#5	10'-10"	—
Structure Excavation		Cu. Yd.	32	
Concrete Structures		Cu. Yd.	57.6	
Reinforcement Bars, Epoxy Coated		Pound	8,490	
Bar Splicer		Each	10	
Furnishing Steel Piles HP12x63		Foot	574	
Driving Piles HP12x63		Foot	574	
Test Pile Steel HP12x63		Each	1	
Pile Shoes		Each	15	

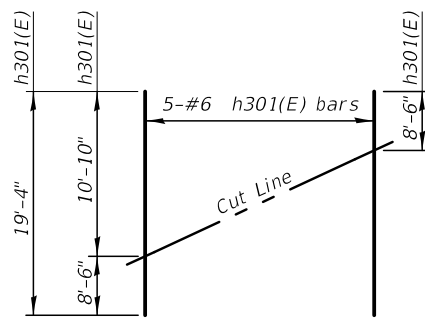

FIELD CUTTING DIAGRAM

Order h301(E) full length. Cut as shown and use remainder of bars in opposite wing.

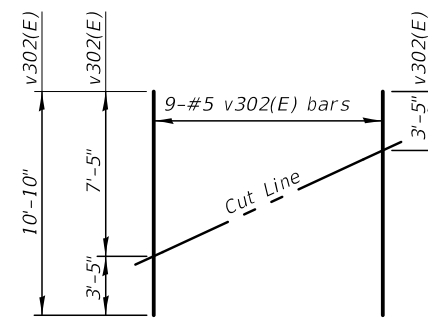

FIELD CUTTING DIAGRAM

Order v302(E) full length. Cut as shown and use remainder of bars in opposite wing.

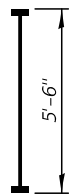

BAR v300(E)
(Headed)

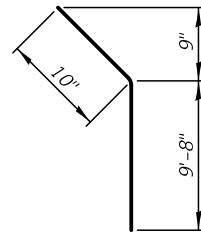

BAR h302(E)

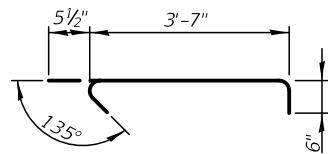

BAR s301(E)

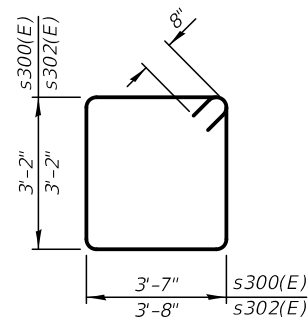

BAR s300(E) & s302(E)

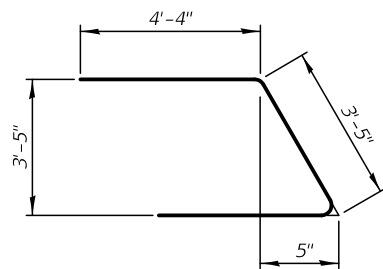

BAR u300(E)

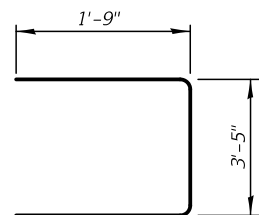

BAR u301(E)

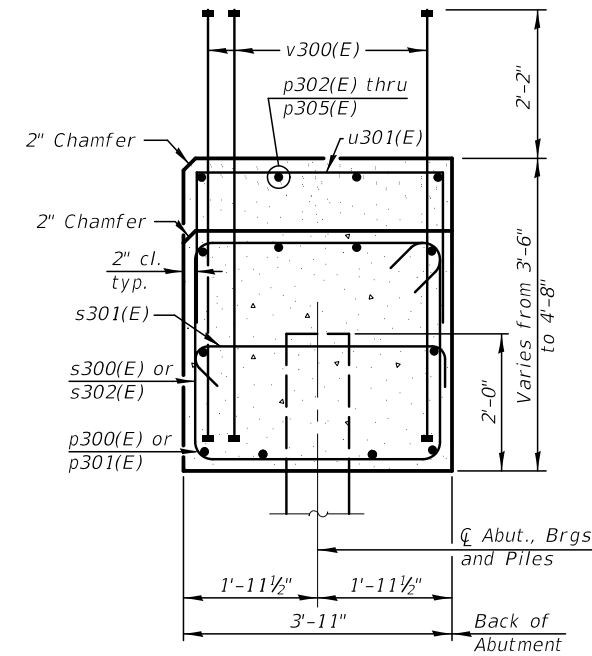

SEC. THRU ABUT.

Dimensions at right angles to abutment.

PLOT DATE = 2/9/2024



DESIGNED - FJW	REVISION
CHECKED - LAS	REVISION
DRAWN - DJC	REVISION
CHECKED - LAS	REVISION

SCALE - NONE	DATE - 2/9/2024
--------------	-----------------

STATE OF ILLINOIS
DEPARTMENT OF TRANSPORTATION

WEST ABUTMENT DETAILS
STRUCTURE NUMBER 022-3055

SHEET S-26 OF 36 SHEETS

F.A.U. RTE.	SECTION	COUNTY	TOTAL SHEETS	SHEET NO.
1479	14-00124-00-BR	DUPAGE	208	144
CONTRACT NO. 61J14				
ILLINOIS FED. AID PROJECT				

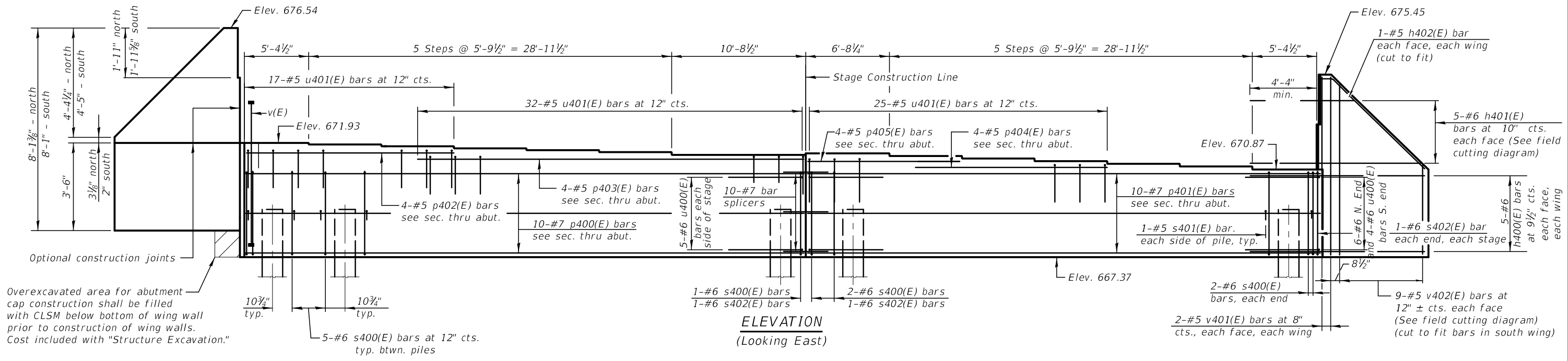

Overexcavated area for abutment cap construction shall be filled with CLSM below bottom of wing wall prior to construction of wing walls. Cost included with "Structure Excavation."

ELEVATION
(Looking East)

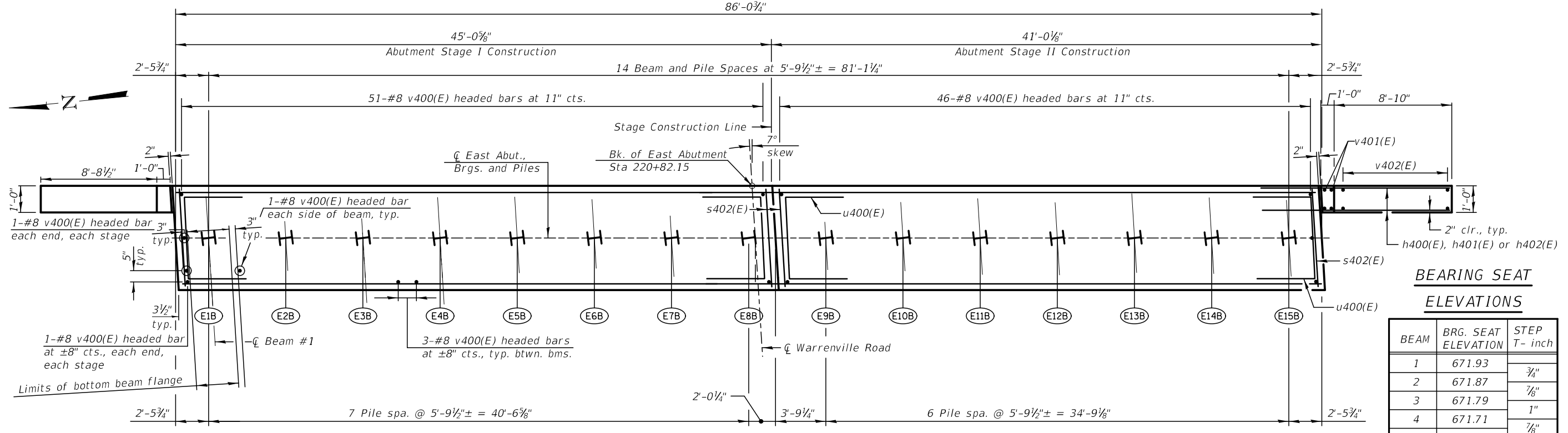

PLAN - EAST ABUTMENT

BEARING SEAT ELEVATIONS

BEAM	BRG. SEAT ELEVATION	STEP T- inch
1	671.93	3/4"
2	671.87	7/8"
3	671.79	1"
4	671.71	7/8"
5	671.64	7/8"
6	671.57	1 3/8"
7	671.45	0"
8	671.45	3/4"
9	671.51	1 1/4"
10	671.41	1 1/4"
11	671.31	1 1/4"
12	671.20	1 1/4"
13	671.10	1 1/4"
14	670.99	1 1/2"
15	670.87	

- NOTES**
1. Pour steps monolithically with cap.
 2. Headed bars shall conform to ASTM A970 with threaded attachment; Class HA; and reinforcement bars conforming to ASTM A706. Cost included with Reinforcement Bars, Epoxy Coated.
 3. For details of piles see drawing S-30.
 4. See Sheet S-28 for East Abutment details.

LEGEND
E.F. Each Face
E1B Pile Number

MIN. BAR LAP
#5 - 3'-7"
#6 - 4'-4"
#7 - 5'-0"

PILE DATA
Type & Size: Steel HP 12x63
Nominal Required Bearing: 497 Kips
Factored Resistance Available: 273 Kips
Est. Length: 38 ft
No. Production Piles: 14
No. Test Piles: 1

PLOT DATE = 2/9/2024

ILLINOIS FED. AID PROJECT

BILL OF MATERIAL

Bar	No.	Size	Length	Shape
h400(E)	20	#6	14'-2"	—
h401(E)	10	#6	19'-4"	—
h402(E)	4	#5	10'-6"	—
p400(E)	10	#7	44'-9"	—
p401(E)	10	#7	40'-9"	—
p402(E)	4	#5	16'-9"	—
p403(E)	4	#5	31'-6"	—
p404(E)	4	#5	15'-6"	—
p405(E)	4	#5	12'-1"	—
s400(E)	72	#6	14'-10"	□
s401(E)	30	#5	4'-7"	□
s402(E)	4	#6	15'-0"	□
u400(E)	20	#6	12'-1"	—
u401(E)	74	#5	6'-11"	—
v400(E)	177	#8	5'-6"	—
v401(E)	8	#5	7'-9"	—
v402(E)	18	#5	10'-10"	—
Structure Excavation		Cu. Yd.	51	
Concrete Structures		Cu. Yd.	56.9	
Reinforcement Bars, Epoxy Coated		Pound	8430	
Bar Splicer		Each	10	
Furnishing Steel Piles HP12x63		Foot	532	
Driving Piles		Foot	532	
Test Pile Steel HP12x63		Each	1	
Pile Shoes		Each	15	

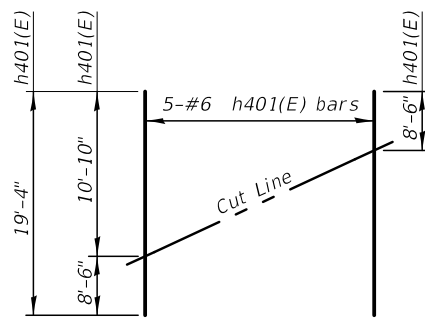

FIELD CUTTING DIAGRAM

Order h401(E) full length. Cut as shown and use remainder of bars in opposite wing.

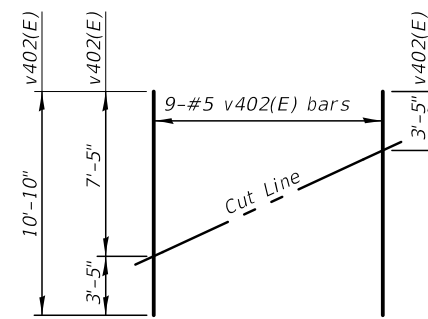

FIELD CUTTING DIAGRAM

Order v402(E) full length. Cut as shown and use remainder of bars in opposite wing.

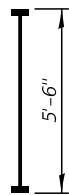

BAR v400(E)
(Headed)

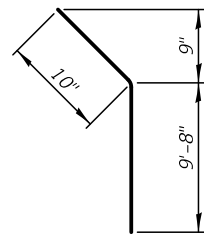

BAR h402(E)

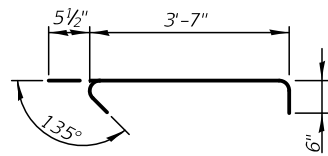

BAR s401(E)

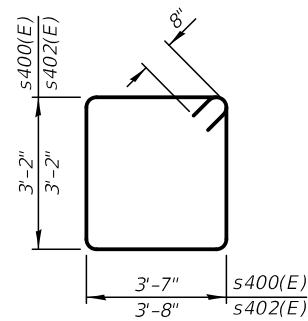

BAR s400(E) & s402(E)

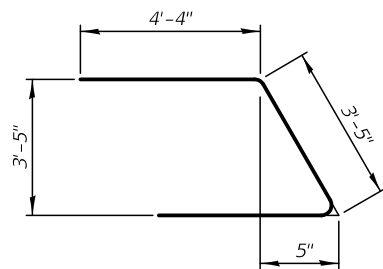

BAR u400(E)

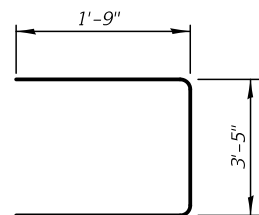

BAR u401(E)

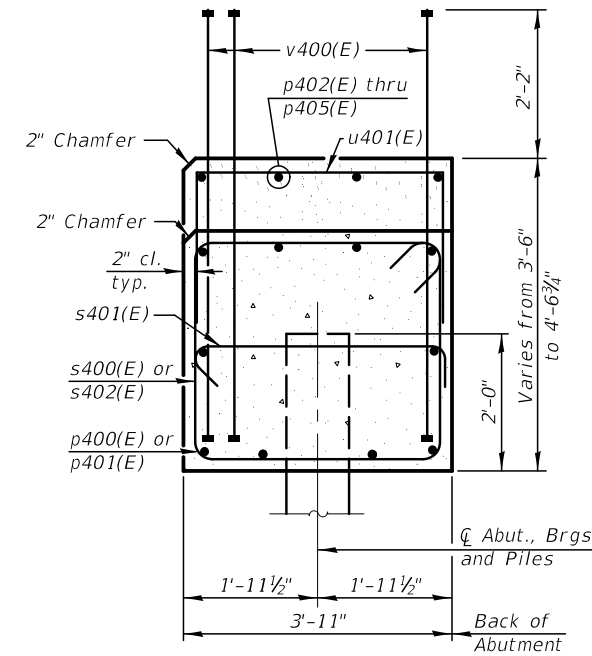

SEC. THRU ABUT.

Dimensions at right angles to abutment.

PLOT DATE = 2/9/2024



DESIGNED - FJW	REVISION
CHECKED - LAS	REVISION
DRAWN - DJC	REVISION
CHECKED - LAS	REVISION
SCALE - NONE	
DATE - 2/9/2024	

DESIGNED - FJW	REVISION
CHECKED - LAS	REVISION
DRAWN - DJC	REVISION
CHECKED - LAS	REVISION

STATE OF ILLINOIS
DEPARTMENT OF TRANSPORTATION

EAST ABUTMENT DETAILS
STRUCTURE NUMBER 022-3055

SHEET S-28 OF 36 SHEETS

F.A.U. RTE.	SECTION	COUNTY	TOTAL SHEETS	SHEET NO.
1479	14-00124-00-BR	DUPAGE	208	146
CONTRACT NO. 61J14				
ILLINOIS FED. AID PROJECT				

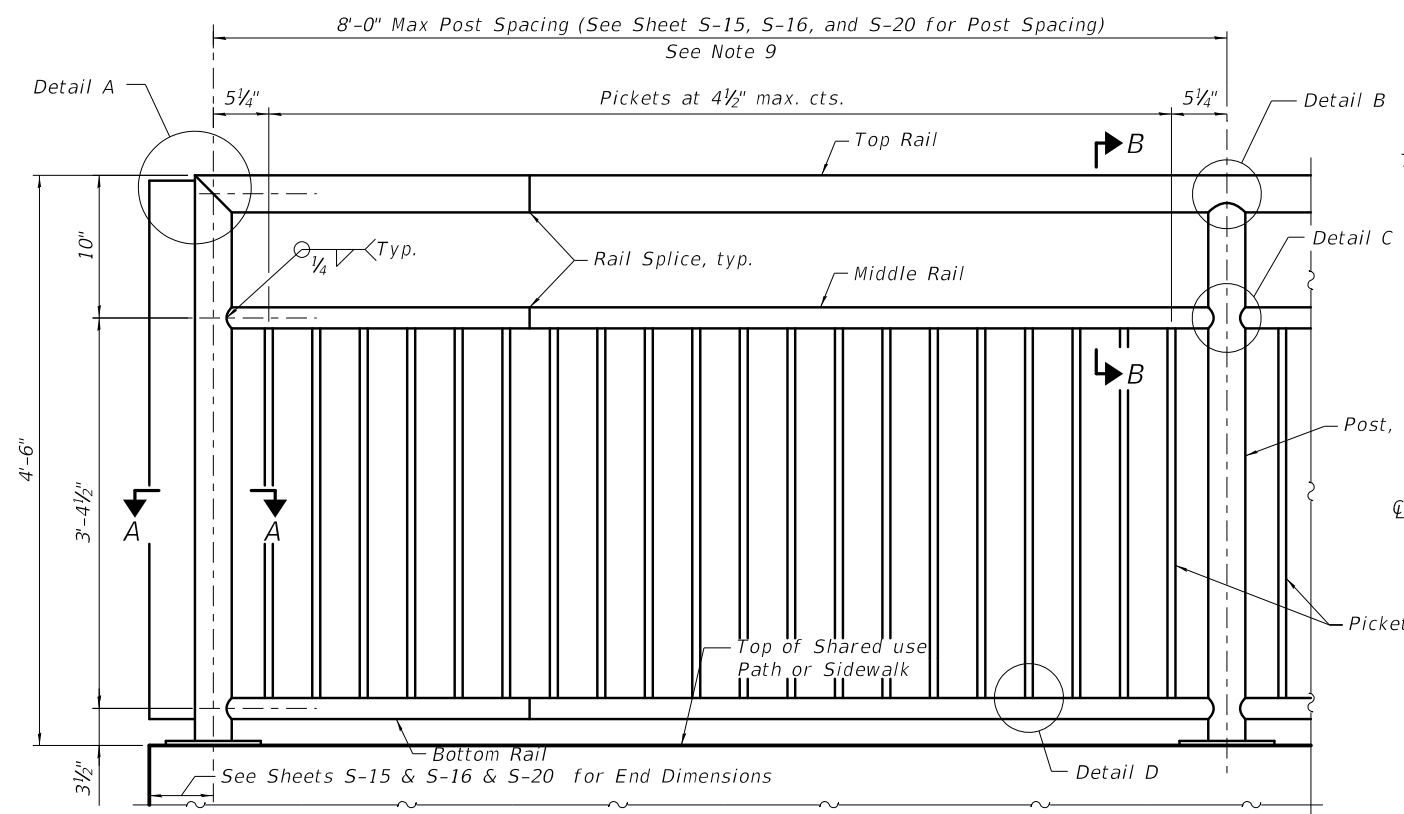

BICYCLE RAILING ELEVATION

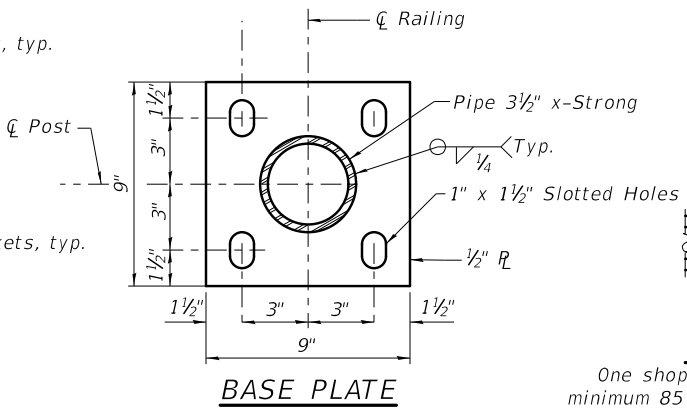
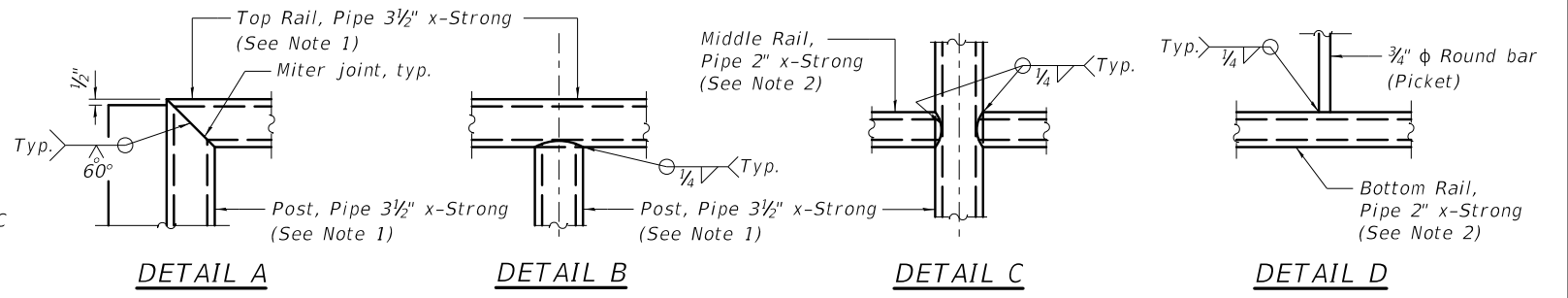

BASE PLATE

RAIL SHOP SPLICE
One shop splice per panel is permitted with minimum 85 percent penetration. The weld may be square groove or single vee groove. Grind smooth

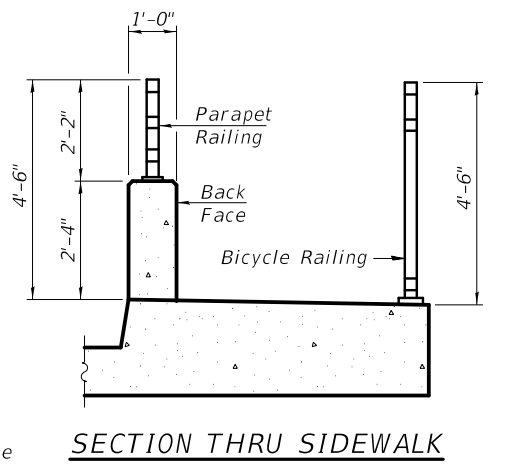

SECTION THRU SIDEWALK

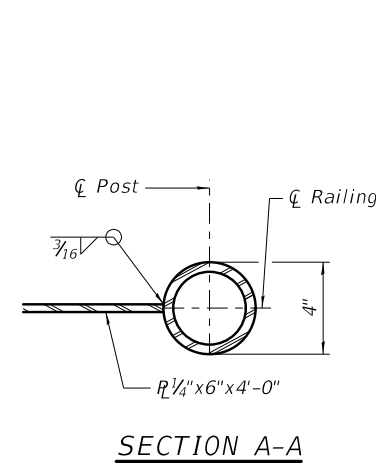

SECTION A-A

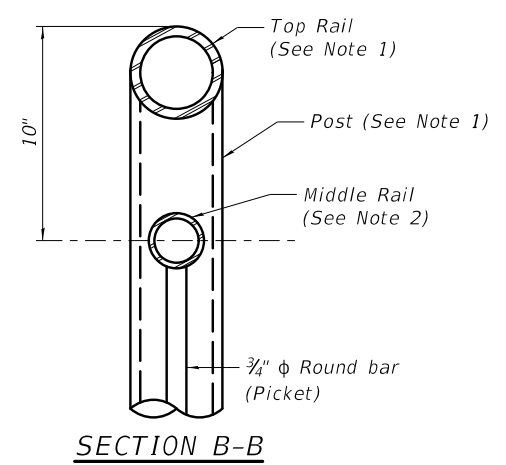

SECTION B-B

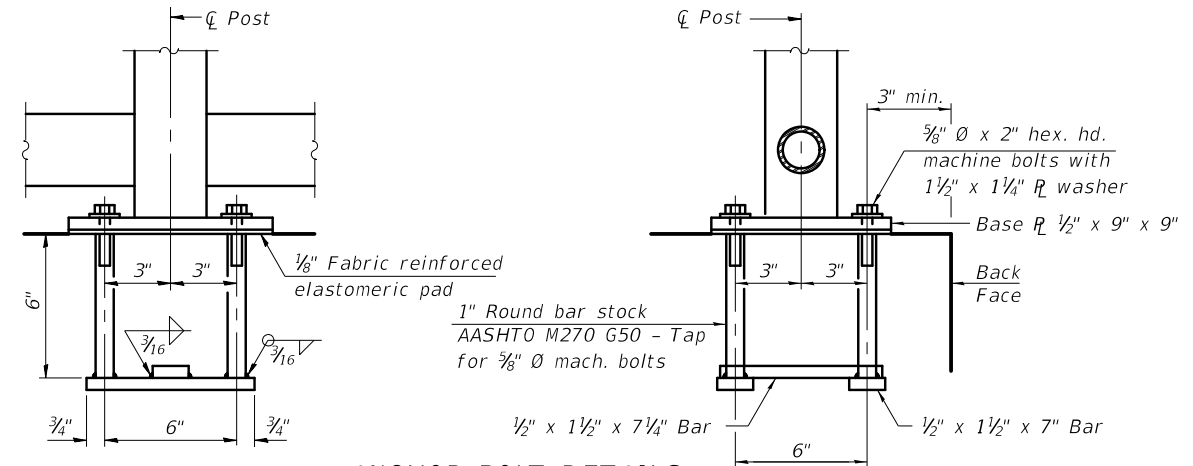

ANCHOR BOLT DETAILS

In lieu of the cast-in-place anchor device shown, the Contractor has the option of drilling and setting 5/8" Ø anchor rods according to Article 509.06 of the Standard Specifications. Embedment shall be according to the manufacturer's specifications.

- Notes:
1. Use Pipe 3 1/2" x-Strong (4" O.D., 0.318" wall thickness) for posts and top rail. Provide holes as needed in post and top rail for powder coating drainage and hanging. Plumb all posts.
 2. Use 2" O x-Strong Pipe (2.380" O.D., 0.218" wall thickness) for middle and bottom rails. Parallel to top of shared use path or sidewalk. Provide holes as needed for powder coating drainage and hanging.
 3. Pipe will conform to ASTM-A53 Grade B. Steel plates and steel bars will conform to AASHTO M270 Gr. 50.
 4. All rail elements shall be powder coated according to ASTM D7803.
 5. Railing and any wall or other surface adjacent to them shall be free of any sharp or abrasive elements.
 6. Submit shop drawings to the Engineer unless noted otherwise.
 7. For all railings, erection drawings shall be submitted for approval to ensure proper installation. Drawings shall show field splice locations, railing expansion joints (placed at the existing joint locations in the reinforced concrete wall), post spacing, anchor bolt drilling and setting procedures, profile slope, splice joint locations, shim plates, and railing lengths with identification showing where each railing goes on the layout.
 8. Railing shall be fabricated such that longitudinal elements are parallel to the top of sidewalk and posts are plumb. Contractor shall field verify sidewalk profile slope.
 9. All exposed edges will be rounded or chamfered to approximately 1/8" by grinding.

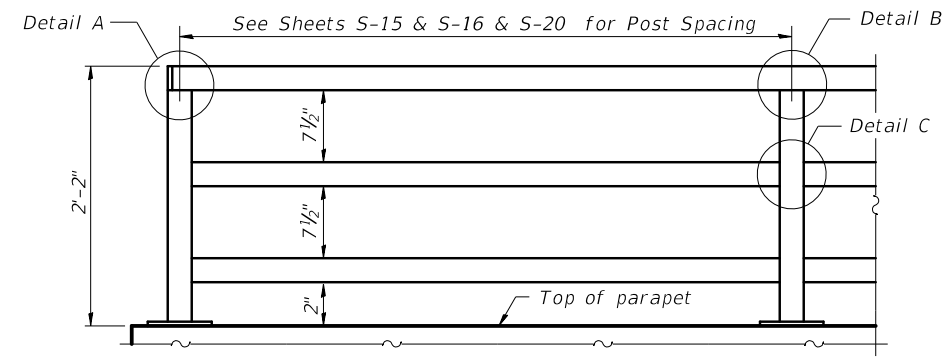

PARAPET RAILING ELEVATION
(Inside Face of Three Element Rail)

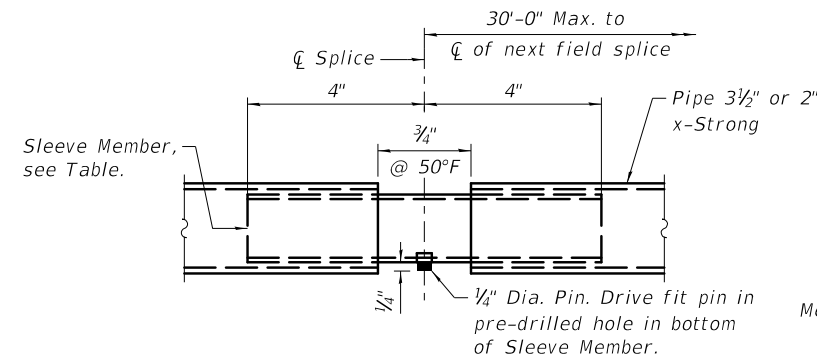

RAIL FIELD SPLICE

SLEEVE MEMBER

Rail Size	Sleeve Member
3 1/2" x-Strong	3 1/4" O MT Pipe (3 3/4" O.D., 0.120" wall thickness)
2" x-Strong	1 3/16" O MT Pipe (1 3/16" O.D., 0.120" wall thickness)

Mechanical tubing (MT) will conform to ASTM A513 Grade 1015 or higher.

BILL OF MATERIAL

Item	Unit	Quantity
Bicycle Railing	Foot	326
Parapet Railing	Foot	326

PLOT DATE = 2/19/2024

KNIGHT
Member of WSP

DESIGNED - FJW	REVIS
CHECKED - LAS	REVIS
DRAWN - DJC	REVIS
CHECKED - LAS	REVIS

SCALE - NONE	DATE - 2/19/2024
--------------	------------------

STATE OF ILLINOIS
DEPARTMENT OF TRANSPORTATION

BICYCLE RAILING
STRUCTURE NUMBER 022-3055
SHEET S-29 OF 36 SHEETS

F.A.U. RTE. 1479	SECTION 14-00124-00-BR	COUNTY DUPAGE	TOTAL SHEETS 208	SHEET NO. 147
CONTRACT NO. 61J14				
ILLINOIS FED. AID PROJECT				

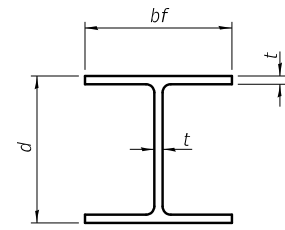

STEEL PILE TABLE

Designation	Depth d	Flange width bf	Web and Flange thickness t	Encasement diameter A
HP 14x117	14 1/4"	14 7/8"	1 3/16"	30"
x102	14"	14 3/4"	1 1/16"	30"
x89	13 7/8"	14 3/4"	5/8"	30"
x73	13 3/8"	14 3/8"	1/2"	30"
HP 12x84	12 1/4"	12 1/4"	1 1/16"	24"
x74	12 1/8"	12 1/4"	5/8"	24"
x63	12"	12 1/8"	1/2"	24"
x53	11 3/4"	12"	7/16"	24"
HP 10x57	10"	10 1/4"	9/16"	24"
x42	9 3/4"	10 1/8"	7/16"	24"
HP 8x36	8"	8 1/8"	7/16"	18"

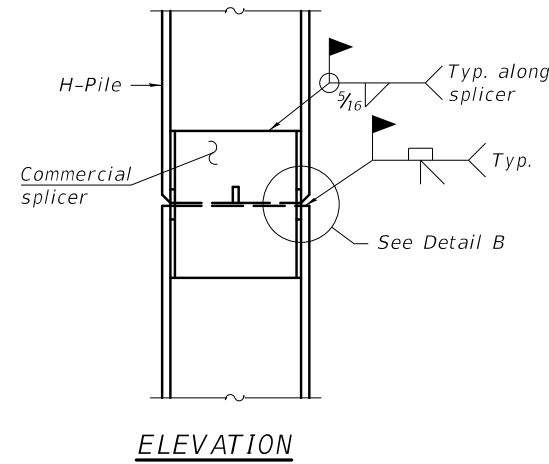

ELEVATION

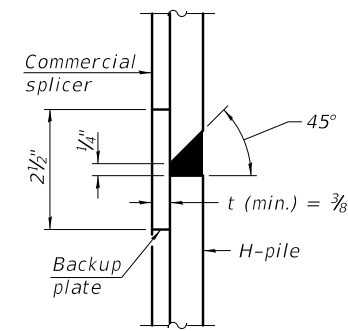

DETAIL "B"

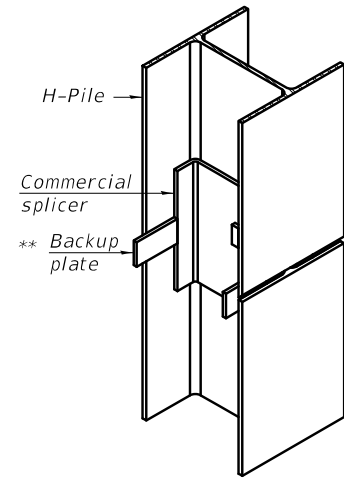

ISOMETRIC VIEW

WELDED COMMERCIAL SPLICE

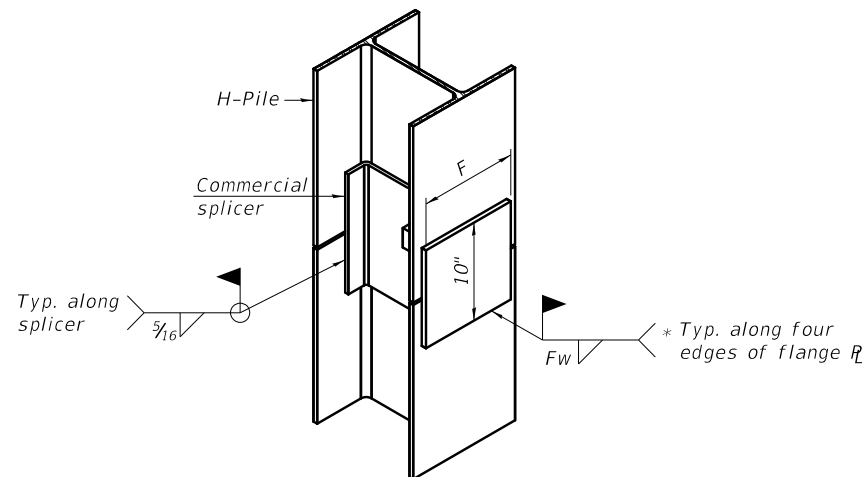

ISOMETRIC VIEW

WELDED COMMERCIAL SPLICE ALTERNATE

- * Interrupt welds 1/4" from end of web and/or each flange.
- ** Remove portions of backup plates that extend outside the flanges.
- *** Weld size per pile shoe manufacturer (5/16" min.).

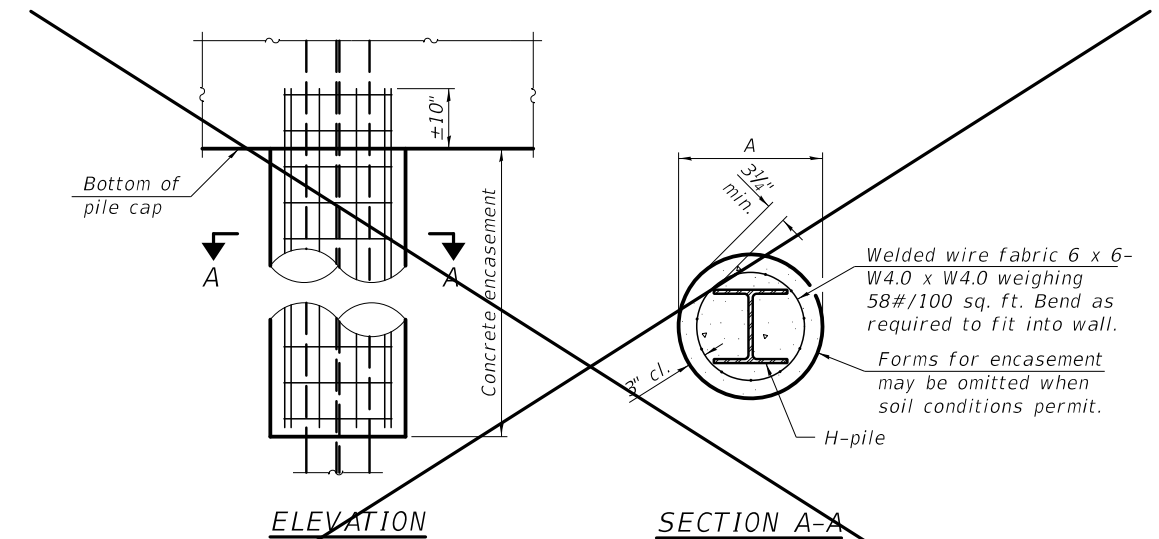

ELEVATION

SECTION A-A

INDIVIDUAL PILE CONCRETE ENCASUREMENT (when specified)

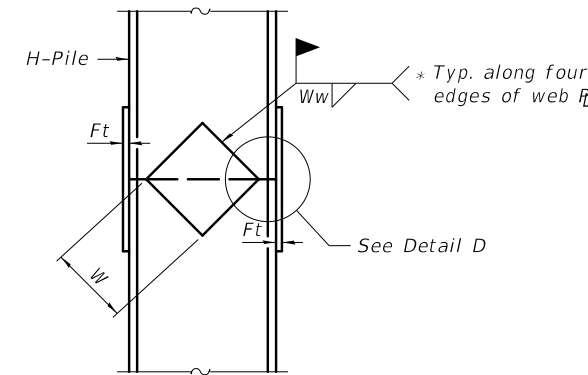

ELEVATION

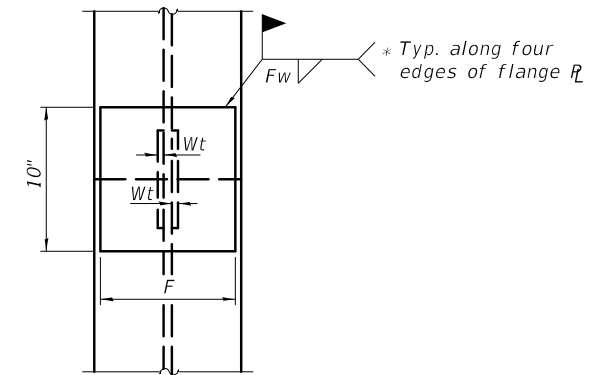

END VIEW

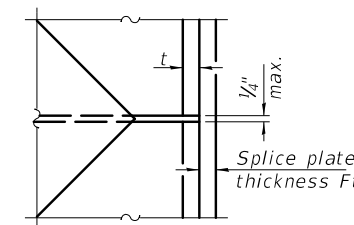

DETAIL D

WELDED PLATE FIELD SPLICE

Designation	F	Ft	Fw	W	Wt	Ww
HP 14x117	12 1/2"	1"	7/8"	7 3/4"	5/8"	1/2"
x102	12 1/2"	7/8"	3/4"	7 3/4"	5/8"	1/2"
x89	12 1/2"	3/4"	1 1/16"	7 3/4"	5/8"	1/2"
x73	12 1/2"	5/8"	9/16"	7 3/4"	5/8"	1/2"
HP 12x84	10"	7/8"	1 1/16"	6 1/2"	5/8"	1/2"
x74	10"	7/8"	1 1/16"	6 1/2"	5/8"	1/2"
x63	10"	5/8"	1/2"	6 1/2"	1/2"	3/8"
x53	10"	5/8"	1/2"	6 1/2"	1/2"	3/8"
HP 10x57	8"	3/4"	9/16"	5 1/4"	1/2"	3/8"
x42	8"	5/8"	9/16"	5 1/4"	1/2"	3/8"
HP 8x36	7"	5/8"	7/16"	4 1/4"	1/2"	3/8"

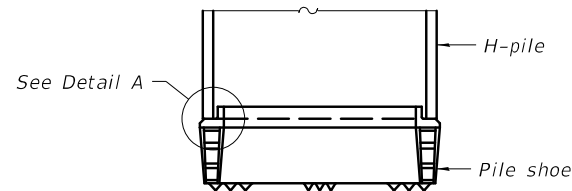

ELEVATION

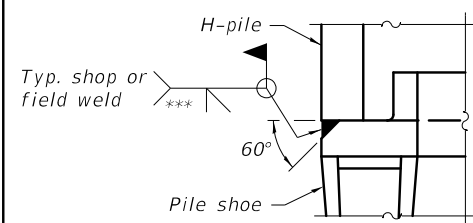

DETAIL A

SHOE ATTACHMENT

Note:
The steel H-piles shall be according to AASHTO M270 Grade 50.

F-HP 1-1-2020



DESIGNED - FJW	REVIS
CHECKED - LAS	REVIS
SCALE - NONE	REVIS
DATE - 2/9/2024	REVIS

DRAWN - DJC	REVIS
CHECKED - LAS	REVIS

STATE OF ILLINOIS
DEPARTMENT OF TRANSPORTATION

HP PILE DETAILS
STRUCTURE NUMBER 022-3055
SHEET S-30 OF 36 SHEETS

F.A.U. RTE.	SECTION	COUNTY	TOTAL SHEETS	SHEET NO.
1479	14-00124-00-BR	DUPAGE	208	148
CONTRACT NO. 61J14				

ILLINOIS FED. AID PROJECT

PLOT DATE = 2/9/2024

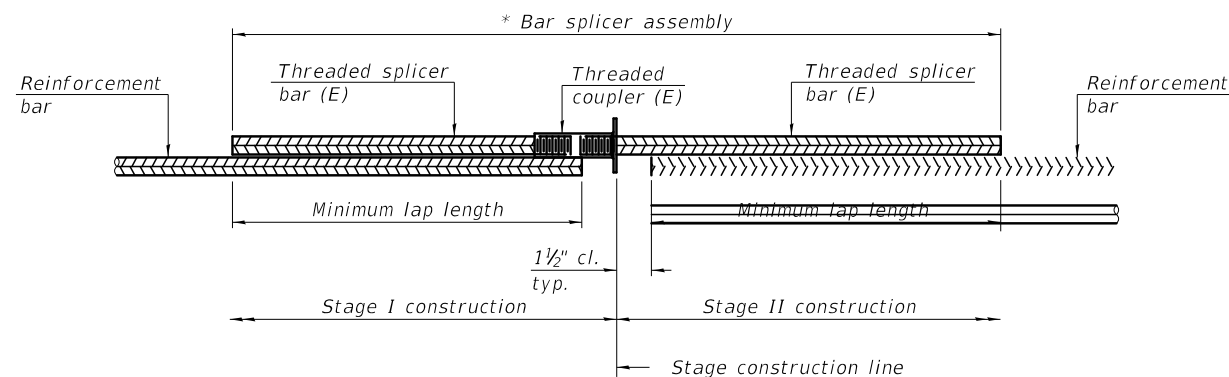

STANDARD BAR SPLICER ASSEMBLY PLAN

(All components shall be provided from one supplier)

Threaded splicer bar length = min. lap length + 1 1/2" + thread length

* Epoxy not required on Bar Splicer Assembly components used in conjunction with black bars.

Location	Bar size	No. assemblies required	Minimum lap length
West Abutment	#7	10	5'-0"
East Abutment	#7	10	5'-0"
Deck (Top Bars)	#5	166	3'-6"
Deck (Bottom Bars)	#5	124	3'-6"
Diaphragm	#6	8	4'-0"
Diaphragm** (Between webs)	#6	4	2'-9", 1'-6"
Diaphragm** (Between flanges)	#6	2	1'-9", 6"
Approach slab	#5	90	3'-6"
Approach slab	#8	120	6'-4"
Approach Footing	#5	80	3'-6"

** See Bar Splicer Assembly at Stage Construction Line detail below.

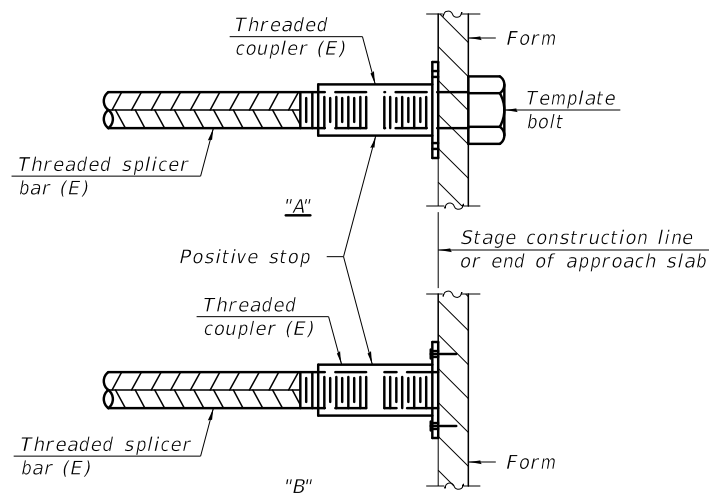

INSTALLATION AND SETTING METHODS

"A" : Set bar splicer assembly by means of a template bolt.

"B" : Set bar splicer assembly by nailing to wood forms or cementing to steel forms.

(E) : Indicates epoxy coating.

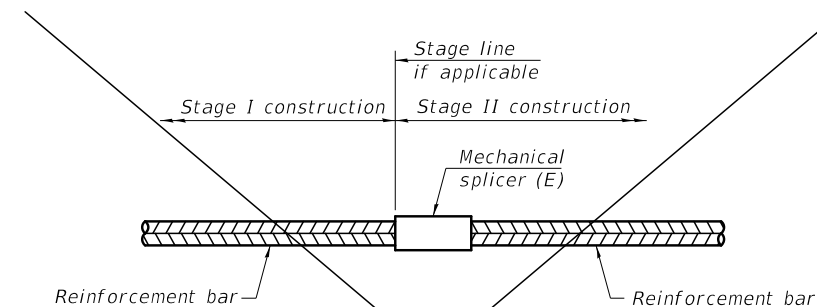

STANDARD MECHANICAL SPLICER

Location	Bar size	No. assemblies required

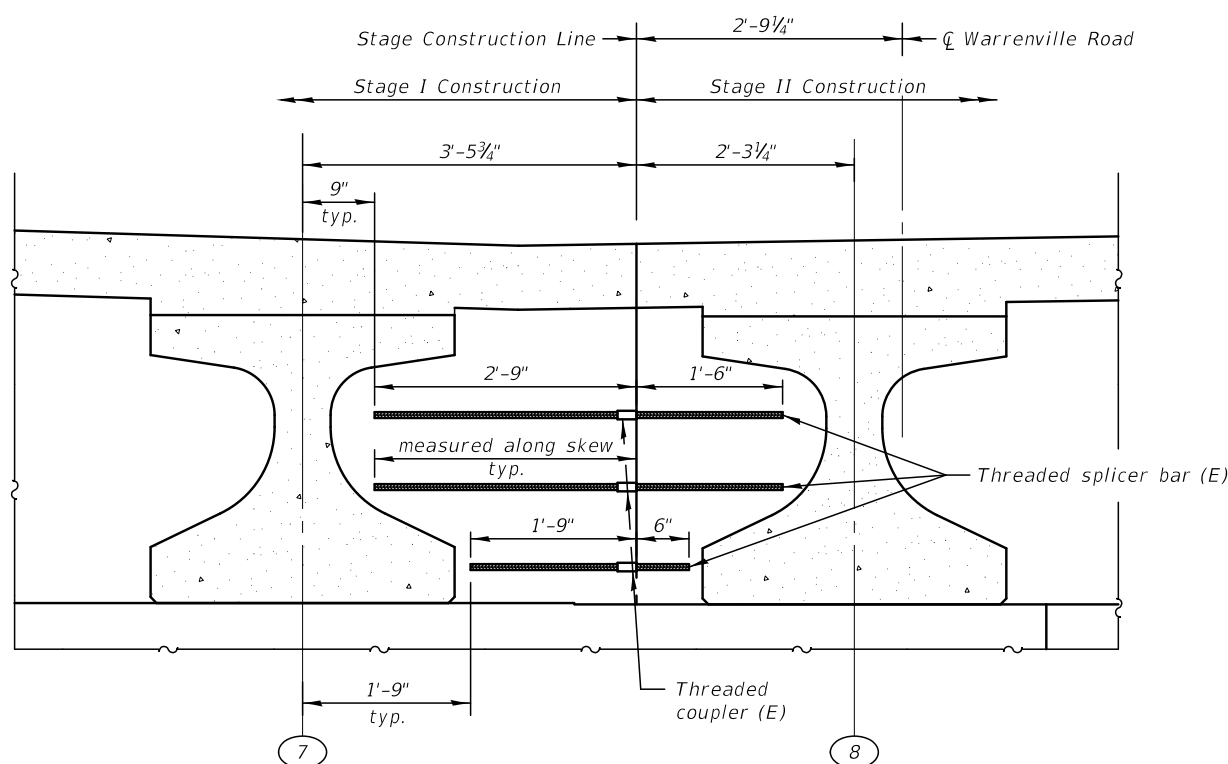

BAR SPLICER ASSEMBLY

AT STAGE CONSTRUCTION LINE

(Dimensions are at right angles to Warrenville Road unless noted otherwise.)

Notes:
 Splicer bars shall be deformed with threaded ends and have a minimum 60 ksi yield strength.
 All reinforcement shall be lapped and tied to the splicer bars.
 Bar splicer assemblies shall be epoxy coated according to the requirements for reinforcement bars. See Section 508 of the Standard Specifications.
 See approved list of bar splicer assemblies and mechanical splicers for alternatives.

PLOT DATE = 2/9/2024

BSD-1 1-1-2020



DESIGNED - FJW	REVISD
CHECKED - LAS	REVISD
SCALE - NONE	REVISD
DATE - 2/9/2024	REVISD

STATE OF ILLINOIS
DEPARTMENT OF TRANSPORTATION

BAR SPLICER ASSEMBLY AND MECHANICAL SPLICER DETAILS
STRUCTURE NUMBER 022-3055

SHEET S-31 OF 36 SHEETS

F.A.U. RTE.	SECTION	COUNTY	TOTAL SHEETS	SHEET NO.
1479	14-00124-00-BR	DUPAGE	208	149
CONTRACT NO. 61J14				

ILLINOIS FED. AID PROJECT

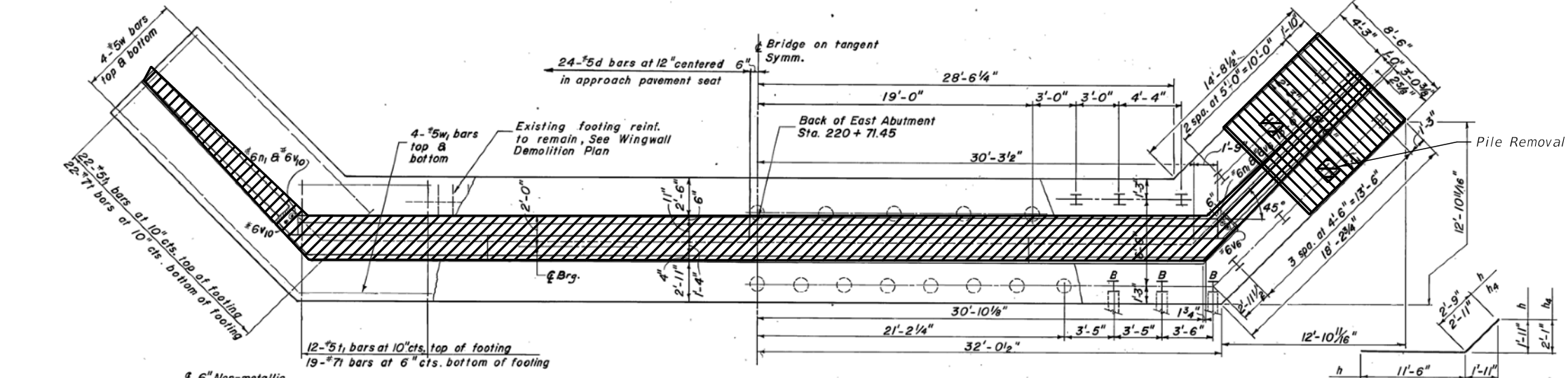
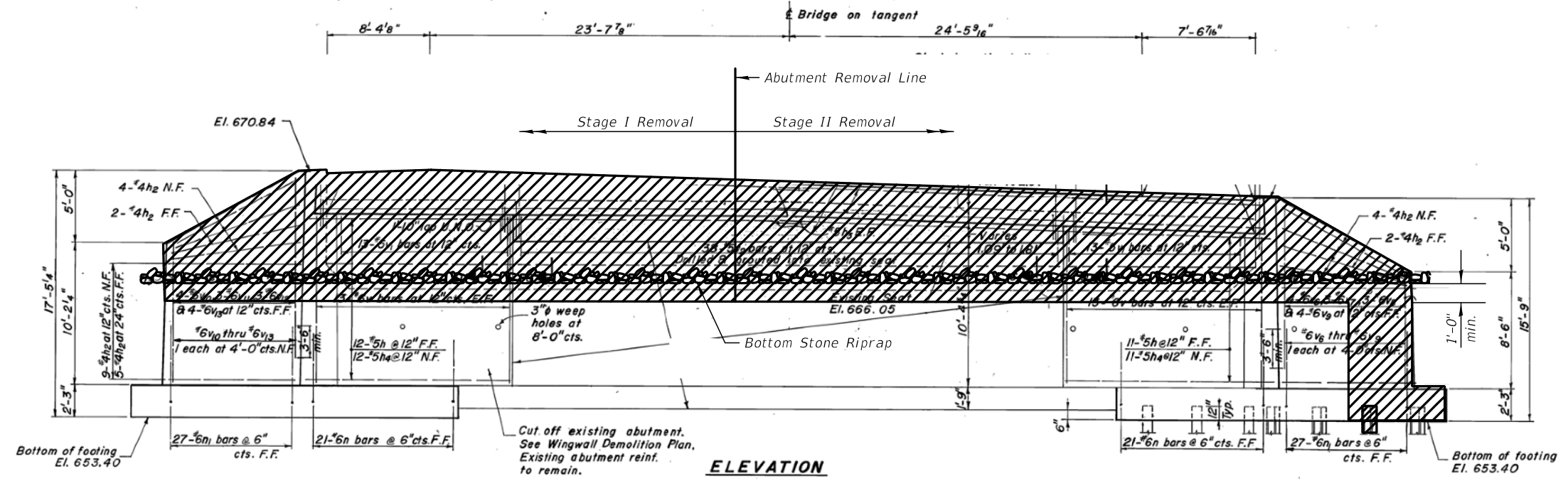

BAR	NO.	SIZE	LENGTH	SHAPE
d	48	"5	2'-6"	—
h	23	"5	14'-3"	—
h ₁	18	"5	33'-2"	—
h ₂	40	"4	13'-3"	—
h ₃	4	"5	21'-6"	—
n	42	"6	7'-6"	—
n ₁	56	"6	8'-3"	—
h ₄	23	"5	15'-1"	—
t	82	"7	9'-6"	—
t ₁	68	"5	8'-0"	—
v	52	"6	10'-9"	—
v ₁	26	"5	5'-8"	—
v ₂	38	"5	5'-6"	—
v ₃	66	"5	9'-6"	—
v ₄	66	"5	4'-6"	—
v ₅	28	"5	8'-6"	—
v ₆	7	"4	12'-3"	—
v ₇	4	"6	11'-1"	—
v ₈	4	"6	9'-11"	—
v ₉	5	"6	8'-5"	—
v ₁₀	7	"6	13'-5"	—
v ₁₁	4	"6	2'-3"	—
v ₁₂	4	"6	11'-1"	—
v ₁₃	5	"6	9'-7"	—
w	6	"5	18'-1"	—
w ₁	16	"5	10'-0"	—

Class X Concrete	Cu.Yds.	93.0
Reinforcement Bars	Lbs.	6580
Steel Piles (HP 8 x 36)	Lin.Ft.	400
Test Piles	Ea.	1
Concrete Removal	Cu.Yds.	37

LEGEND
 N.F. = Near Face
 F.F. = Far Face
 E.F. = Each Face

PILE DATA
 Type: Steel HP 8x36
 No. Req'd: 26
 Est. Length: 16'-0"
 Drive To Refusal

FOR REMOVAL INFORMATION ONLY

LEGEND:
 Abutment Removal

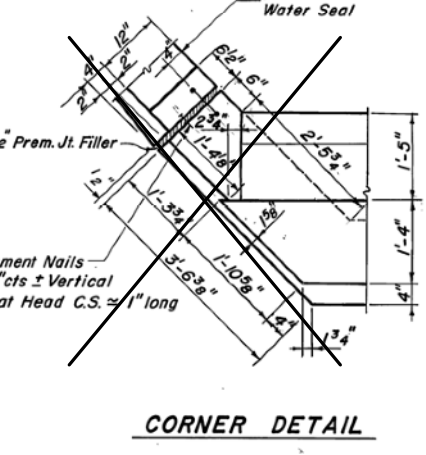
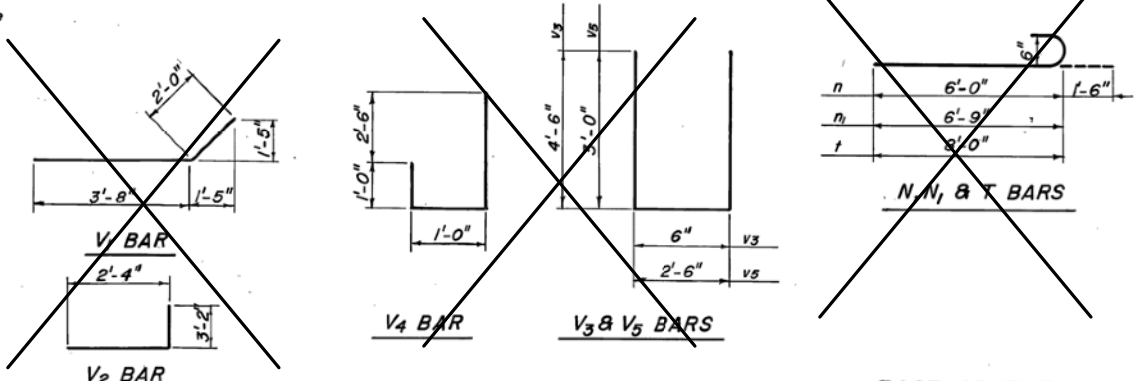

CEMCON, Ltd.
 Consulting Engineers, Land Surveyors & Planners

933 WEST LIBERTY DRIVE
 WHEATON, ILLINOIS 60187
 PHONE: AC 312/653-1030

prepared for
Du PAGE COUNTY HIGHWAY DEPARTMENT
 130 No. COUNTY FARM ROAD WHEATON, ILLINOIS 60187

REVISIONS			
NO.	DATE	DESCRIPTION	
1	7/17/81 TM		

Job No. 365.002		SHEET	
Dra By: D.M. - T.M.		11 of 24	
Ckd By: J.S.P.			

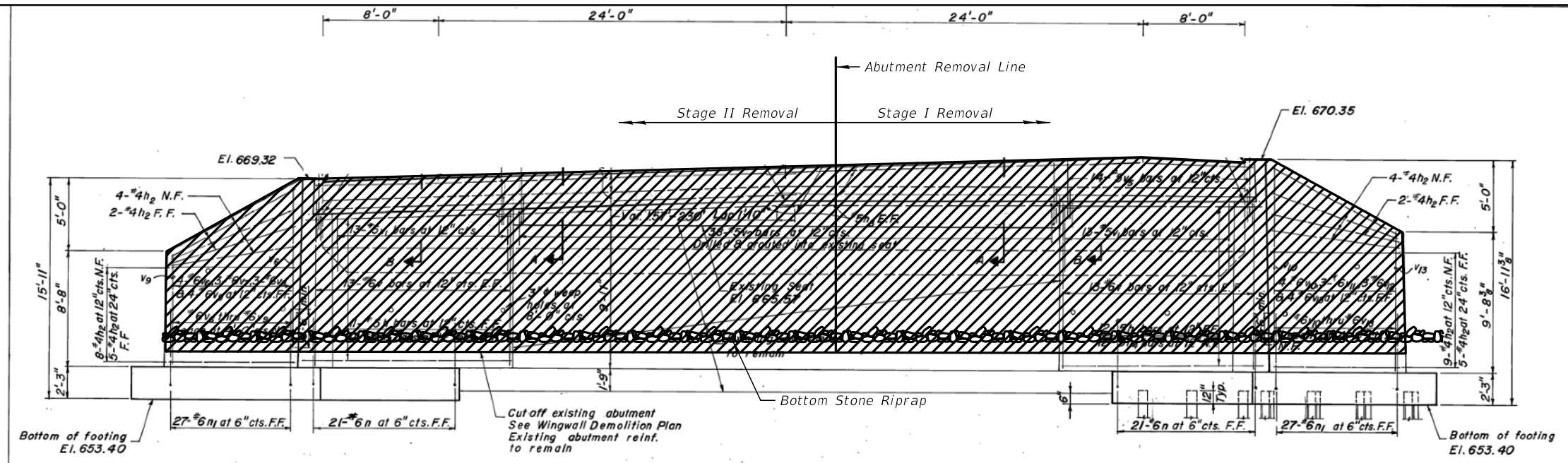

ELEVATION

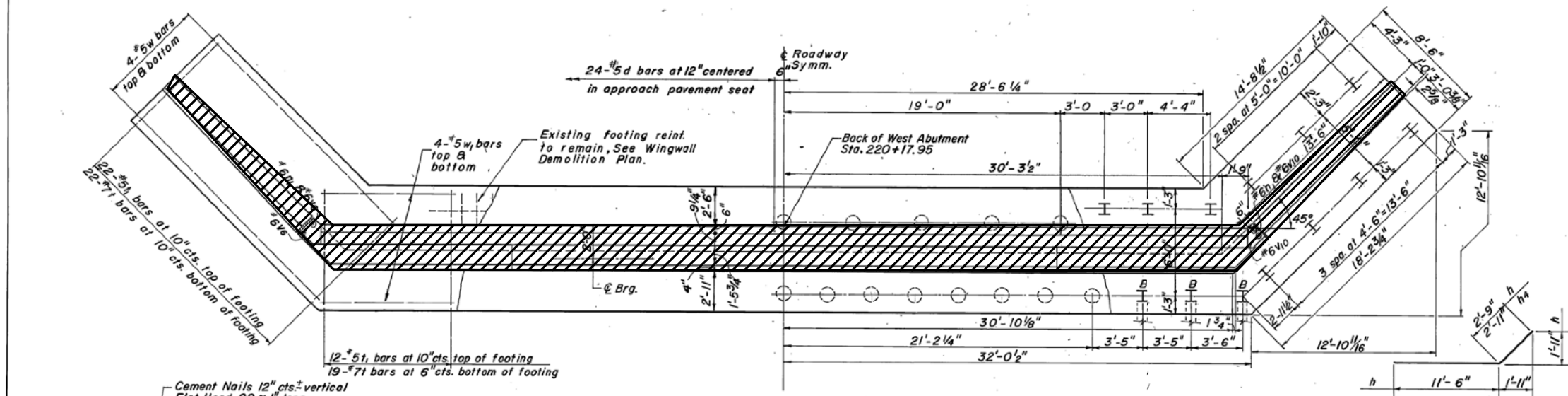

PLAN

Note: B indicates Battered Piles (6 Req'd.) 3"/ft.

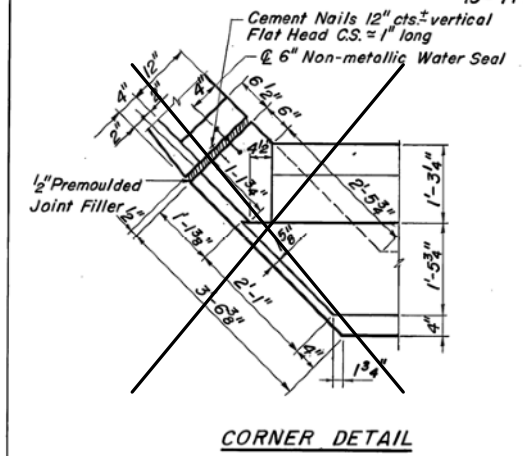

CORNER DETAIL

FOR REMOVAL INFORMATION ONLY

LEGEND:
 Abutment Removal

LEGEND
 N.F. = Near Face
 F.F. = Far Face
 E.F. = Each Face

PILE DATA
 Type: Steel HP 8x36
 No. Req'd: 26
 Est. Length: 18'-0"
 Drive To Refusal

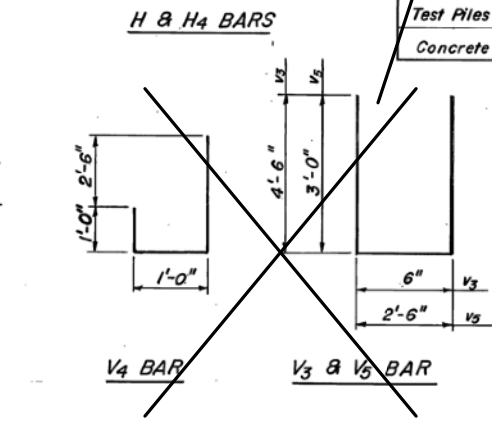

BILL OF MATERIAL				
BAR	NO.	SIZE	LENGTH	SHAPE
d	48	#5	2'-6"	—
h	23	#5	14'-3"	—
h	18	#5	33'-2"	—
h	39	#4	13'-3"	—
h ₃	4	#5	21'-6"	—
h ₄	23	#5	15'-1"	—
n	42	#6	7'-6"	U
n ₁	56	#6	8'-3"	U
t	32	#7	9'-6"	U
t ₁	68	#5	8'-0"	—
v	52	#6	10'-9"	—
v ₁	26	#5	5'-8"	—
v ₂	38	#5	5'-6"	—
v ₃	66	#5	9'-6"	—
v ₄	66	#5	4'-6"	—
v ₅	28	#6	8'-6"	—
v ₆	7	#6	12'-3"	—
v ₇	4	#6	11'-1"	—
v ₈	4	#6	9'-11"	—
v ₉	5	#6	8'-5"	—
v ₁₀	7	#6	13'-5"	—
v ₁₁	4	#6	12'-3"	—
v ₁₂	4	#6	11'-1"	—
v ₁₃	5	#6	9'-7"	—
w	16	#5	18'-1"	—
w ₁	16	#5	10'-0"	—
Class X Concrete		Cu. Yds.	34.5	
Reinforcement Bars		Lbs.	8,570	
Steel Piles (HP 8 X 36)		Lin. Ft.	430	
Test Piles		Ea.	1	
Concrete Removal		Cu. Yds.	37	

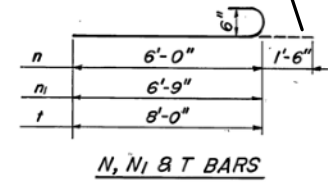

N, N1 & T BARS

CEMCON, Ltd.
 Consulting Engineers, Land Surveyors & Planners

933 WEST LIBERTY DRIVE
 WHEATON, ILLINOIS 60187
 PHONE: AC 312 / 653-1030

prepared for
DUPAGE COUNTY HIGHWAY DEPARTMENT
 130 No. COUNTY FARM ROAD WHEATON, ILLINOIS 60187

REVISIONS			
NO.	DATE	DESCRIPTION	

WEST ABUTMENT
 Job No. 385.002
 Dra By: D.M.-T.M.
 Ckd By:
SHEET
 10 of 24

PLOT DATE = 2/9/2024

KNIGHT
 Member of WSP

DESIGNED - FJW	REVISED
CHECKED - LAS	REVISED
DRAWN - DJC	REVISED
CHECKED - LAS	REVISED
SCALE - NONE	
DATE - 2/9/2024	

STATE OF ILLINOIS
 DEPARTMENT OF TRANSPORTATION

EXISTING WEST ABUTMENT REMOVAL DETAILS
 STRUCTURE NUMBER 022-3055

SHEET S-33 OF 36 SHEETS

F.A.U. RTE.	SECTION	COUNTY	TOTAL SHEETS	SHEET NO.
1479	14-00124-00-BR	DUPAGE	208	151
CONTRACT NO. 61J14				
ILLINOIS FED. AID PROJECT				

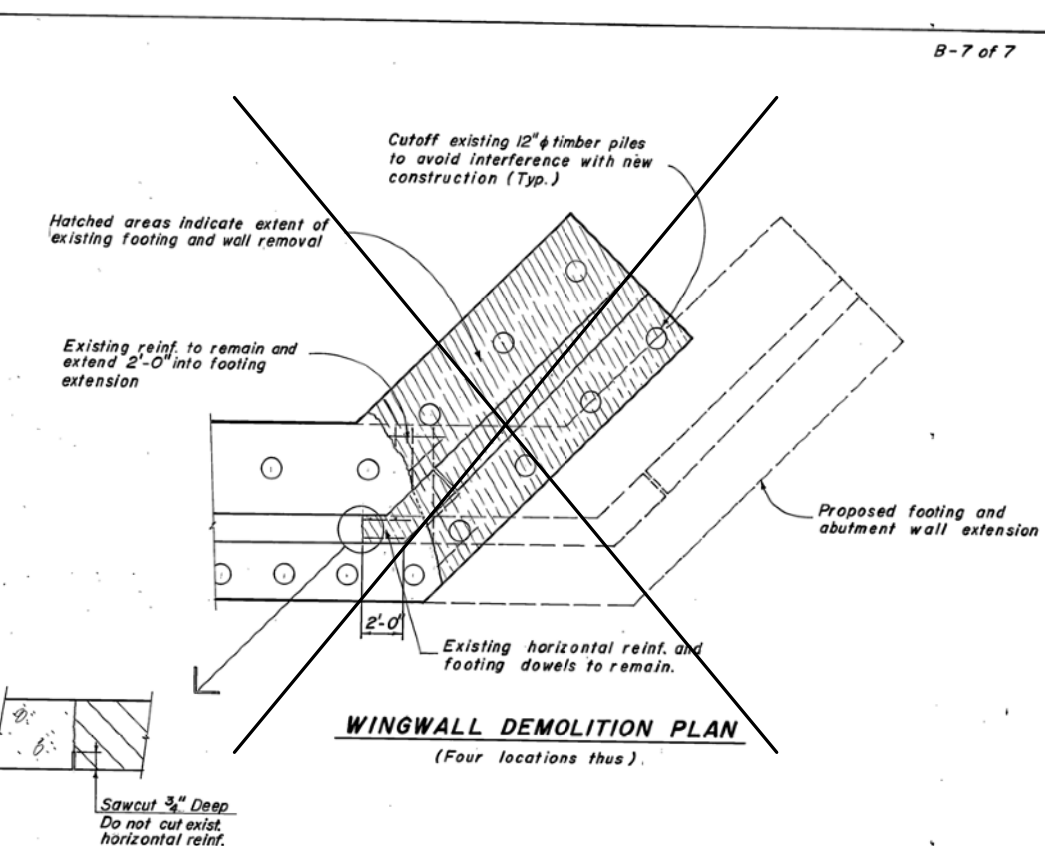
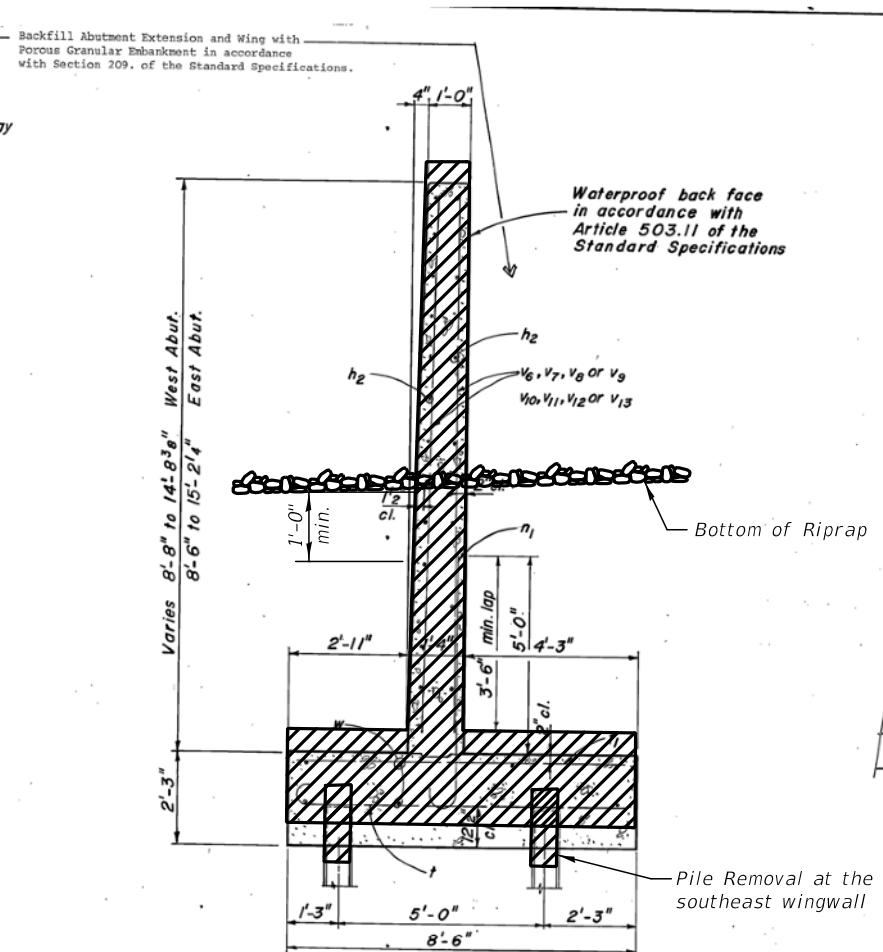
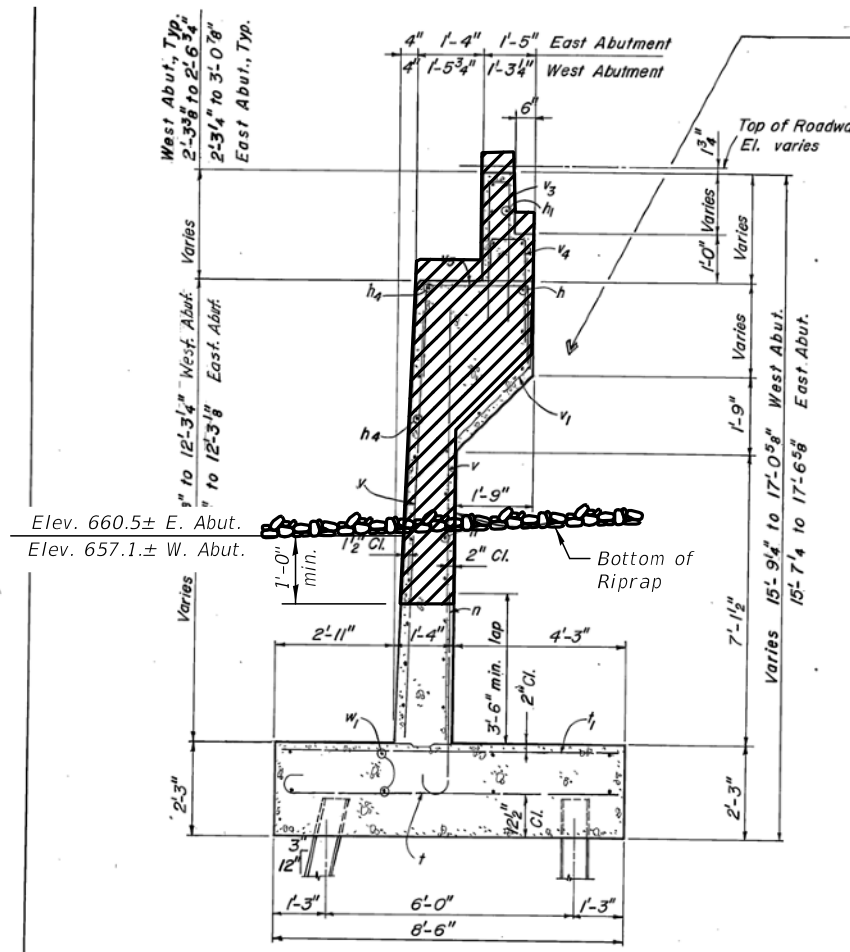

FOR REMOVAL INFORMATION ONLY

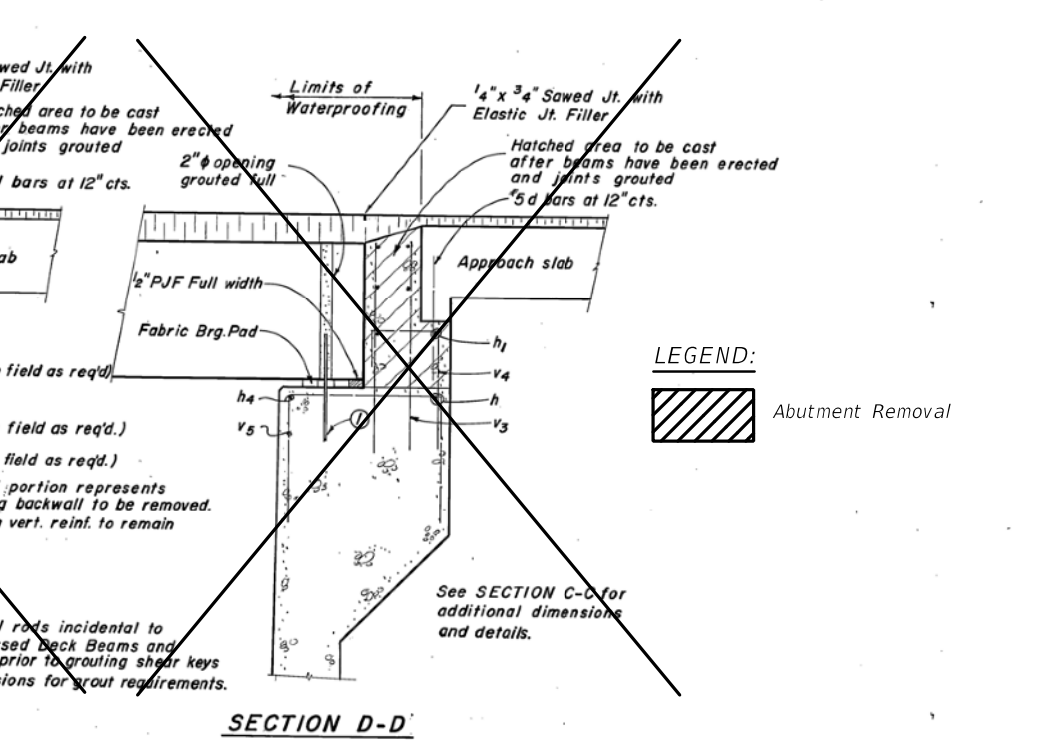
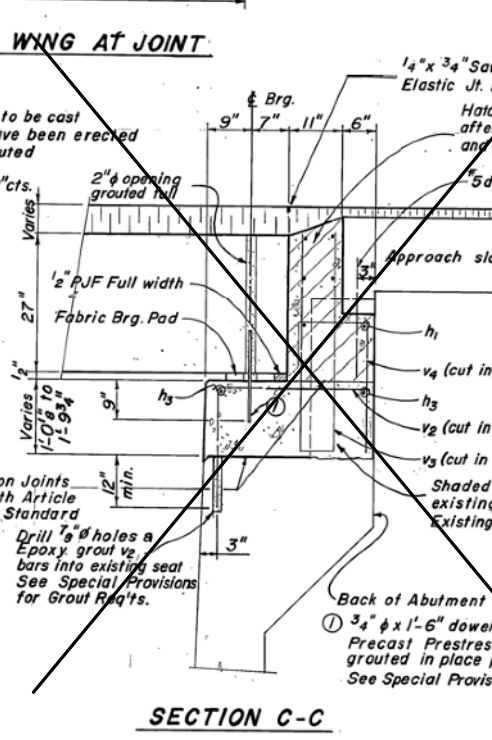
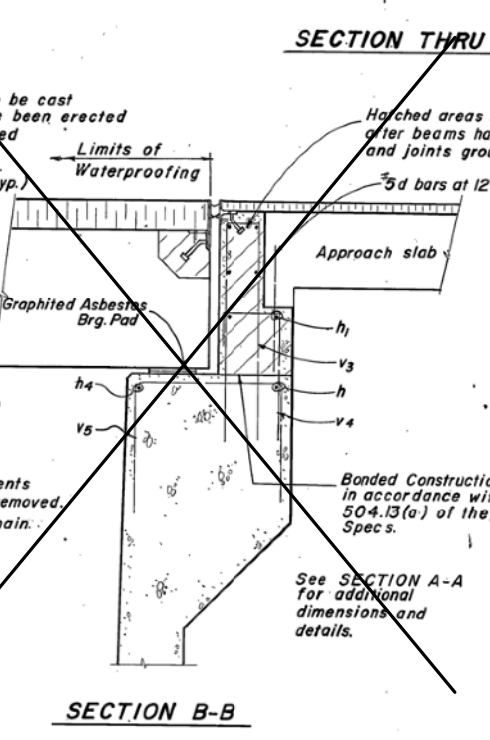
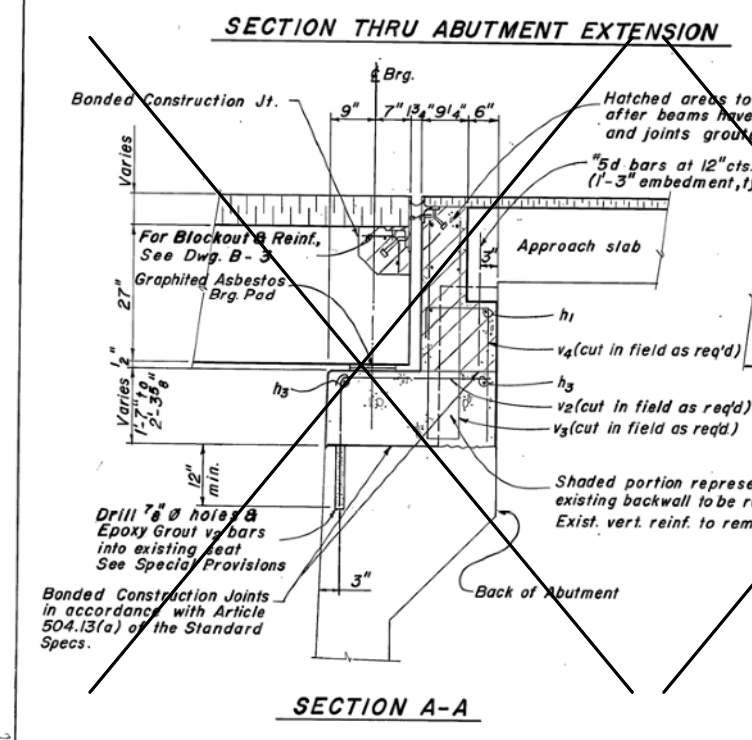

LEGEND:
 Abutment Removal

CEMCON, Ltd.
 Consulting Engineers, Land Surveyors & Planners
 933 WEST LIBERTY DRIVE
 WHEATON, ILLINOIS 60187
 PHONE: AC312/853-1030

prepared for
Du PAGE COUNTY HIGHWAY DEPARTMENT
 130 No. COUNTY FARM ROAD WHEATON, ILLINOIS 60187

ABUTMENT SECTIONS & DETAILS

NO.		DATE		DESCRIPTION	

Job No. 365 002
 Dwn By: D.M. - T.M.
 Ck'd By: J.J.M.

SHEET
 12 of 24

KNIGHT Member of WSP	DESIGNED - FJW	REVISED	STATE OF ILLINOIS DEPARTMENT OF TRANSPORTATION	EXISTING ABUTMENT REMOVAL DETAILS STRUCTURE NUMBER 022-3055 SHEET S-34 OF 36 SHEETS	SECTION	COUNTY	TOTAL SHEETS	SHEET NO.
	CHECKED - LAS	REVISED			1479	14-00124-00-BR	DUPAGE	208
SCALE - NONE	DRAWN - DJC	REVISED						CONTRACT NO. 61J14
DATE - 2/9/2024	CHECKED - LAS	REVISED						ILLINOIS FED. AID PROJECT

ROUTE Warrenville Road DESCRIPTION Bridge Replacement LOGGED BY JH

SECTION NA LOCATION Northside of bridge Northing 1872924.279 Easting 1053102.359

COUNTY Dupage DRILLING METHOD HSA HAMMER TYPE AUTO

STRUCT. NO. 022-3003
 Station NA
 BORING NO. S-01
 Station
 Offset
 Ground Surface Elev. 669.00 ft (ft)

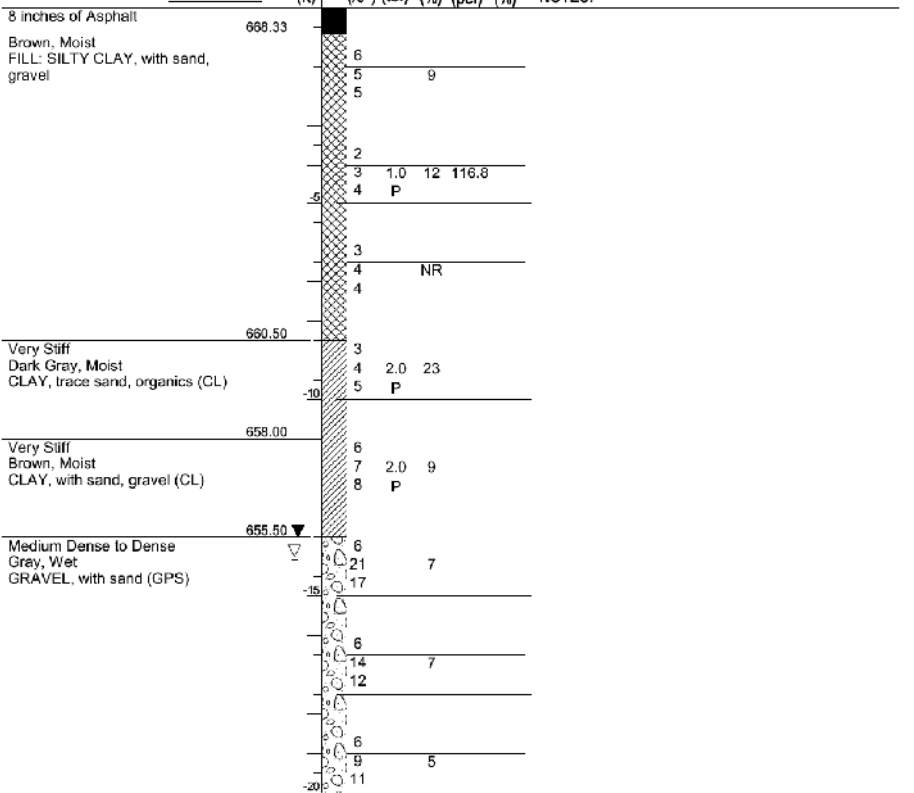

The Unconfined Compressive Strength (UCS) Failure Mode is indicated by (B-Bulge, S-Shear, P-Penetrometer)
 The SPT (N value) is the sum of the last two blow values in each sampling zone (AASHTO T206)

ROUTE Warrenville Road DESCRIPTION Bridge Replacement LOGGED BY JH

SECTION NA LOCATION Northside of bridge Northing 1872924.279 Easting 1053102.359

COUNTY Dupage DRILLING METHOD HSA HAMMER TYPE AUTO

STRUCT. NO. 022-3003
 Station NA
 BORING NO. S-01
 Station
 Offset
 Ground Surface Elev. 669.00 ft (ft)

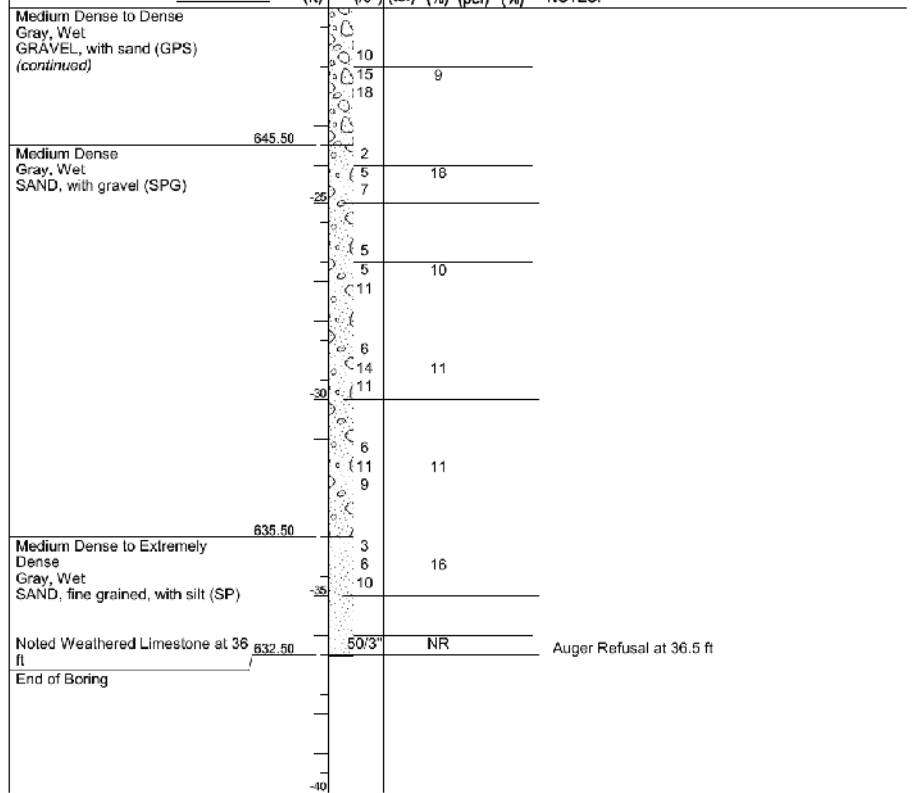

The Unconfined Compressive Strength (UCS) Failure Mode is indicated by (B-Bulge, S-Shear, P-Penetrometer)
 The SPT (N value) is the sum of the last two blow values in each sampling zone (AASHTO T206)

ROUTE Warrenville Road DESCRIPTION Bridge Replacement LOGGED BY JH

SECTION NA LOCATION Southside of bridge Northing 1872847.137 Easting 1053015.617

COUNTY Dupage DRILLING METHOD HSA HAMMER TYPE AUTO

STRUCT. NO. 022-3003
 Station NA
 BORING NO. S-02
 Station
 Offset
 Ground Surface Elev. 663.00 ft (ft)

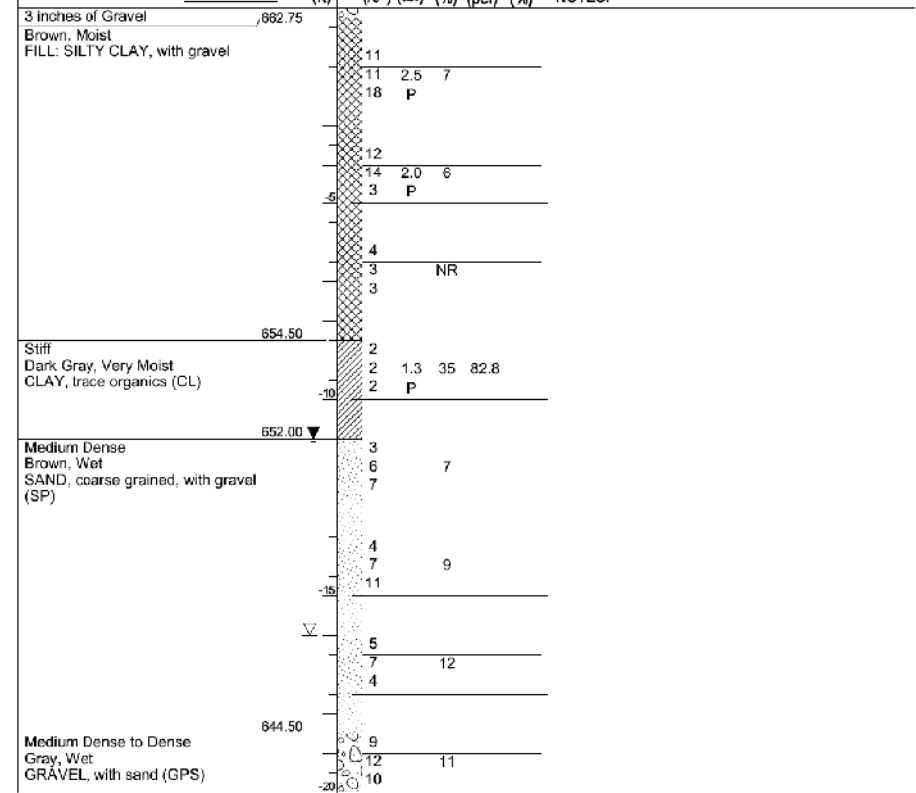

The Unconfined Compressive Strength (UCS) Failure Mode is indicated by (B-Bulge, S-Shear, P-Penetrometer)
 The SPT (N value) is the sum of the last two blow values in each sampling zone (AASHTO T206)

PLOT DATE = 2/9/2024

ROUTE Warrenville Road DESCRIPTION Bridge Replacement LOGGED BY JH
 SECTION NA LOCATION Southside of bridge Northing 1872847.137 Easting 1053015.617
 COUNTY Dupage DRILLING METHOD HSA HAMMER TYPE AUTO

STRUCT. NO. 022-3003 D E P T H LOG (ft) (6") (tsf) (%) (pcf) (%) NOTES:
 Station NA
 BORING NO. S-02
 Station
 Offset
 Ground Surface Elev. 663.00 ft

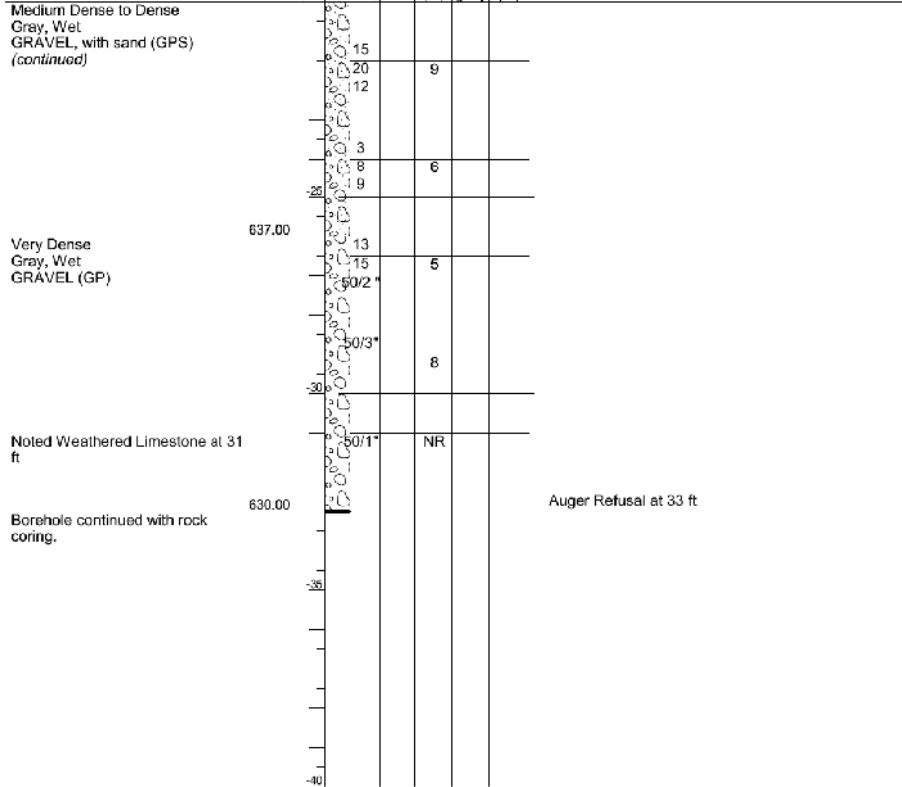

The Unconfined Compressive Strength (UCS) Failure Mode is indicated by (B-Bulge, S-Shear, P-Penetrometer)
 The SPT (N value) is the sum of the last two blow values in each sampling zone (AASHTO T206)

ROUTE Warrenville Road DESCRIPTION Bridge Replacement LOGGED BY JH
 SECTION NA LOCATION Southside of bridge Northing 1872847.137 Easting 1053015.617
 COUNTY Dupage CORING METHOD Rotary, Diamond Bit Core Barrel

STRUCT. NO. 022-3003 CORING BARREL TYPE & SIZE NX 5 split barrel R E C O R D I N G S T R E N G T H
 Station NA D E P T H (ft) (#) (%) (%) (min/ft) (tsf)
 BORING NO. S-02 Core Diameter 2 in
 Station Top of Rock Elev. 632.00 ft
 Offset Begin Core Elev. 630.00 ft
 Ground Surface Elev. 663.00 ft

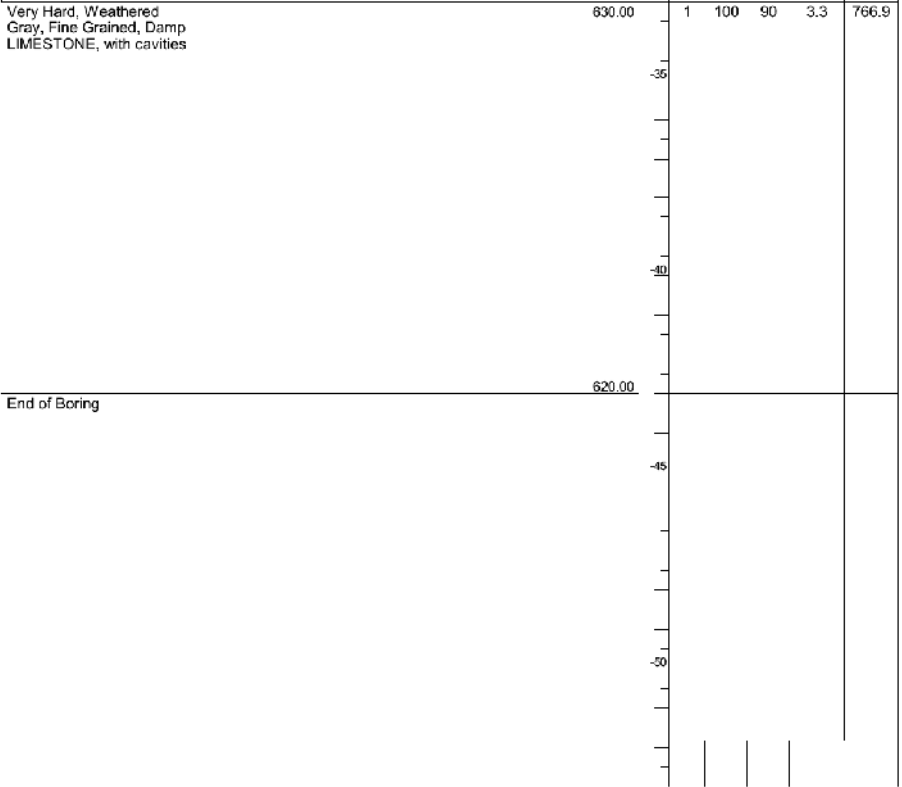

Color pictures of the cores Yes
 Cores will be stored for examination until 1/2016
 The "Strength" column represents the uniaxial compressive strength of the core sample (ASTM D-2938)

PLOT DATE = 2/9/2024

Bench Mark: Bronze disc on top of curb at northeast corner of Warrenville Road Bridge over EB - DuPage River; Elev. - 670.86
 Existing Structure: None.
 Staging: Retaining walls will be constructed during Stage 1 Construction and Two-Way Traffic will be maintained on eastbound lanes.

DESIGN SPECIFICATIONS
 2020 AASHTO LRFD Bridge Design Specifications, 9th Edition

LOADING

2 ft Live Load Surcharge
 Equivalent Fluid Soil Pressure = 40 psf
 $K_a = 0.30$

DESIGN STRESSES

FIELD UNITS
 $f_c = 3,500$ psi
 $f_y = 60,000$ psi (Reinf.)

WEST WALL ELEVATIONS

Mark	Station	Offset	B/Footing Elev.	Proposed Ground Elev.	T/Sidewalk Elev.	T/Wall Elev.
Start	212+79.95	43.19' Lt.	675.24	684.08	684.08	684.08
1	213+06.28	43.60' Lt.	671.39	679.25	682.55	682.82
2	213+56.28	45.25' Lt.	667.53	675.39	680.43	680.43
3	213+62.48	45.50' Lt.	667.53	674.89	680.20	680.22
4	214+46.28	45.85' Lt.	666.41	671.50	677.43	677.43
End	215+25.24	46.18' Lt.	666.41	675.00	675.25	675.25

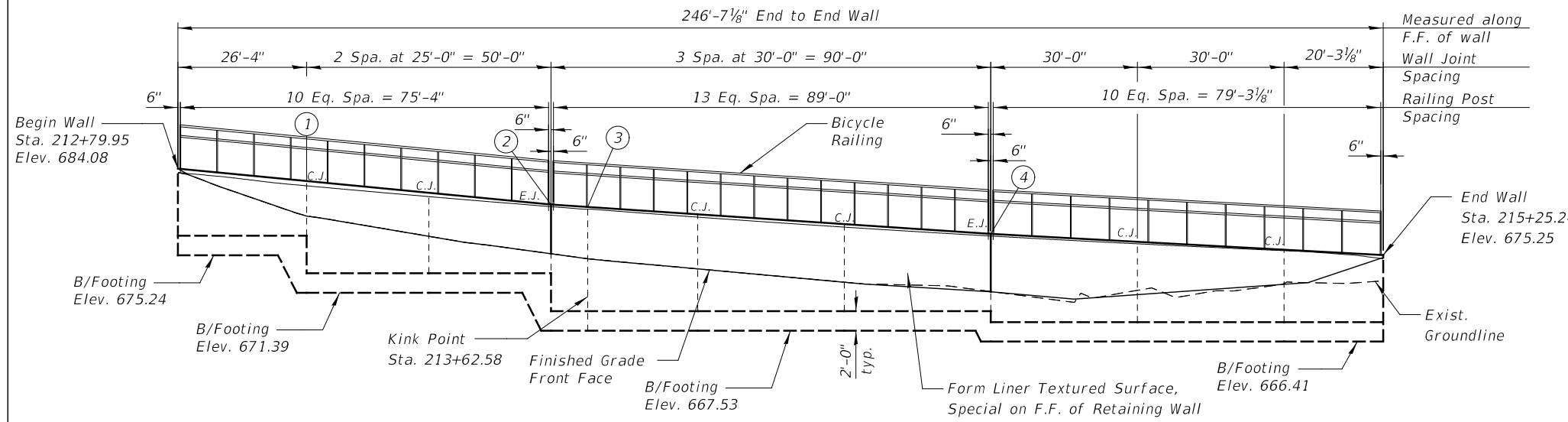

ELEVATION
 (Looking North at Back Face of Wall)

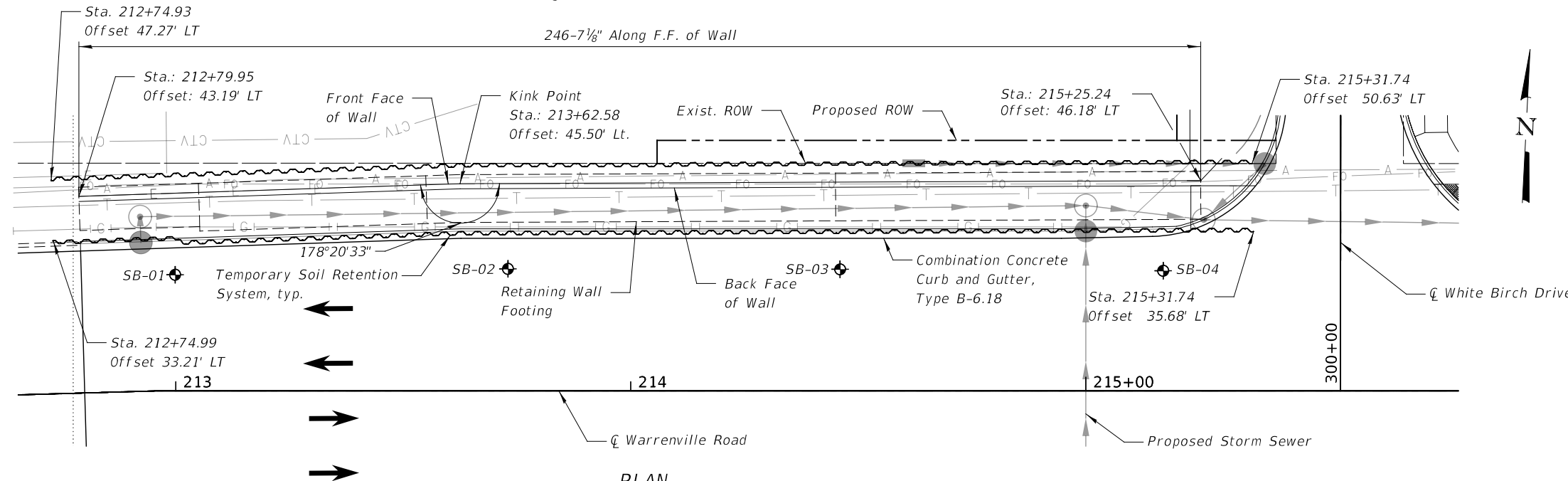

PLAN

Notes:
 Wall offsets are measured from \bar{C} Warrenville Rd. to the front face of retaining wall.
 Temporary Soil Retention System must be staged with the storm sewer installation.
 F.F. - Front Face
 B.F. - Back Face

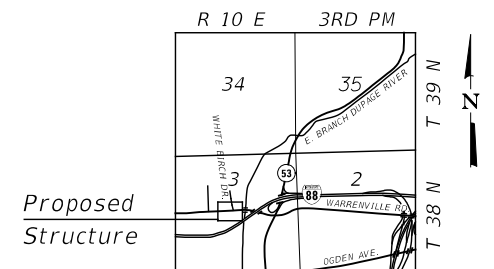

LOCATION SKETCH

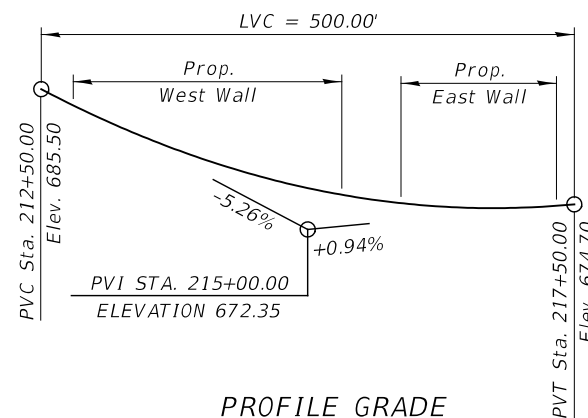

PROFILE GRADE
 (Along \bar{C} Warrenville Road)

LEGEND

- A — Existing Aerial lines
- T — Existing Underground Telephone
- FO — Existing Underground Fiber Optic
- G — Existing Underground Gasline
- CTV — Existing Underground Cable TV
- E — Existing Underground Electric
- ⊕ Soil Boring

GENERAL PLAN & ELEVATION - 1
WARRENVILLE ROAD
RETAINING WALL
F.A.U. RTE. 1479
DUPAGE COUNTY
STA. 212+79.95



I certify that to the best of my knowledge, information and belief, this design is structurally adequate for the design loading shown on the plans. The design is an economical one for the style of structure and complies with the requirements of the current AASHTO LRFD Bridge Design Specifications.

DATE 12/18/2023

PATRICK J. LAUX, P.E., S.E.
 ILLINOIS LICENSED STRUCTURAL ENGINEER
 LICENSE EXPIRES 11-30-2024.

PLOT DATE = 2/9/2024



DESIGNED - NR	REVIS
CHECKED - MS	REVIS
DRAWN - MN	REVIS
CHECKED - MS	REVIS

STATE OF ILLINOIS
 DEPARTMENT OF TRANSPORTATION

GENERAL PLAN & ELEVATION - 1
 WEST RETAINING WALL

SHEET SA-01 OF 13 SHEETS

F.A.U. RTE.	SECTION	COUNTY	TOTAL SHEETS	SHEET NO.
1479	14-00124-00-BR	DUPAGE	208	155
CONTRACT NO. 61J14				

ILLINOIS FED. AID PROJECT

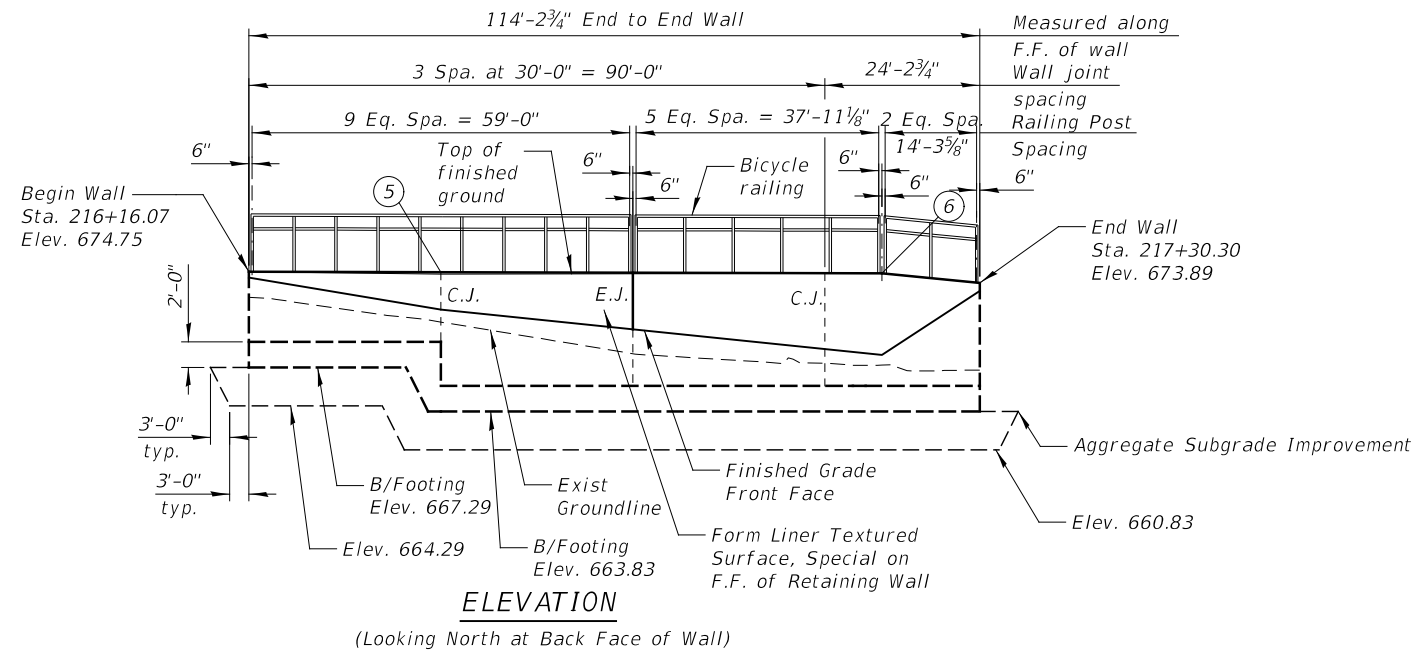

EAST WALL ELEVATIONS

Mark	Station	Offset	B/Footing Elev.	Proposed Ground Elev.	T/Sidewalk Elev.	T/Wall Elev.
Start	216+16.07	46.50' Lt.	667.29	674.30	674.75	674.75
5	216+46.07	46.50' Lt.	663.83	671.80	674.58	674.72
6	217+15.00	46.50' Lt.	663.83	668.25	674.64	674.64
End	217+30.30	46.50' Lt.	663.83	673.25	673.89	673.89

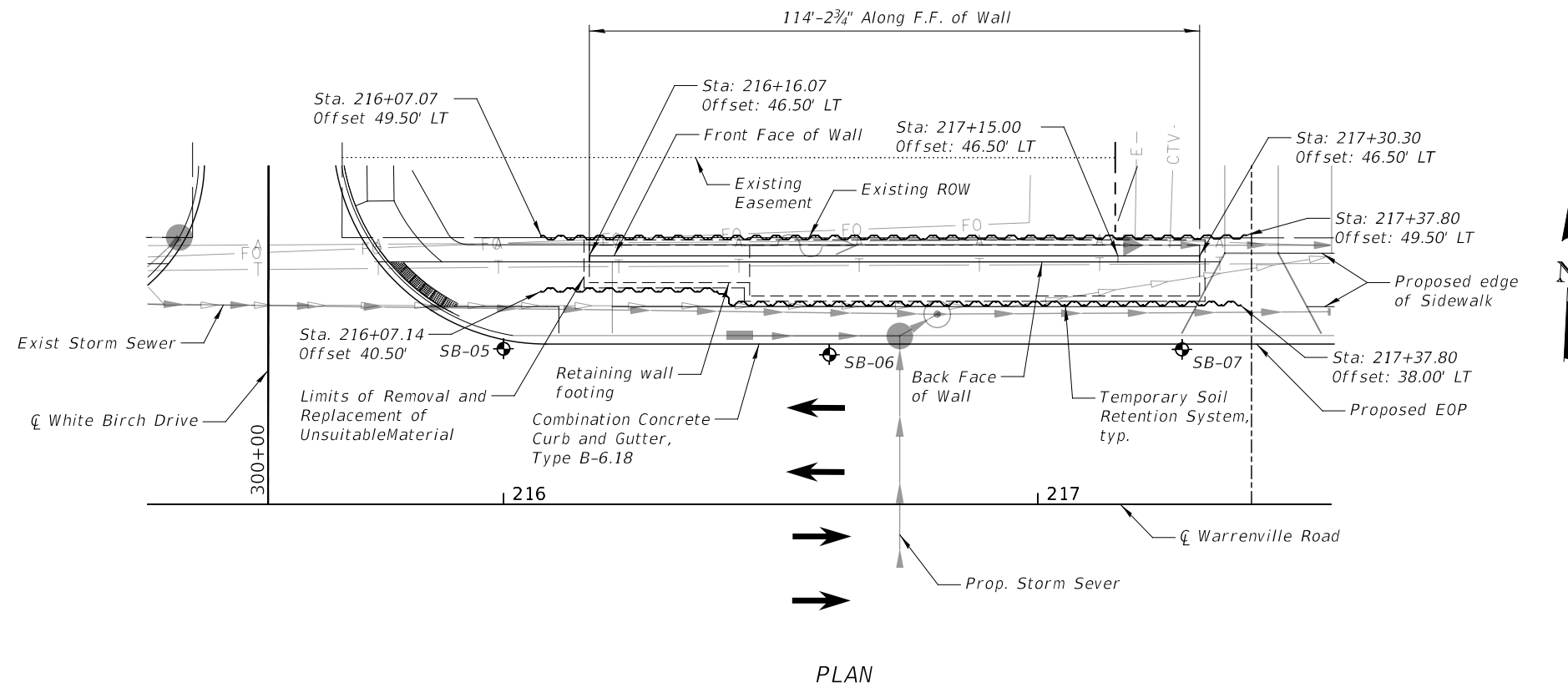

Notes

For legend, see SA-01
Existing Utilities to be relocated

GENERAL PLAN & ELEVATION - 2
WARRENVILLE ROAD
RETAINING WALL
F.A.U. RTE. 1479
DUPAGE COUNTY
STA. 212+79.95

PLOT DATE = 2/9/2024

KNIGHT Member of WSP	DESIGNED - NR	REVISOR	STATE OF ILLINOIS DEPARTMENT OF TRANSPORTATION	GENERAL PLAN & ELEVATION - 2 EAST RETAINING WALL	F.A.U. RTE. 1479	SECTION 14-00124-00-BR	COUNTY DUPAGE	TOTAL SHEETS 208	SHEET NO. 156
	SCALE - NONE	CHECKED - MS			REVISOR	CONTRACT NO. 61J14			
DATE - 2/9/2024	CHECKED - MS	REVISOR	SHEET SA-02 OF 13 SHEETS		ILLINOIS FED. AID PROJECT				

GENERAL NOTES

Bars indicated thus 1 x 2-#8 etc. indicate 1 line of bars with 2 lengths per line.
 Reinforcement bars designated (E) shall be epoxy-coated.
 All exposed concrete edges shall be chamfered 3/4" except as noted.
 Backfill remainder of structure excavation and over excavation with the same material specified for roadway embankment.
 Any unsuitable material, as identified by the Engineer, encountered below the proposed footing limits shall be removed in accordance with Article 502.
 Existing Utilities will be removed and relocated prior to construction.
 Contractor shall not scale dimensions from the Contract Plans for construction purposes. Scales shown are for information only.
 No construction joints except those shown on the plans will be allowed unless approved by the Engineer.
 It shall be the Contractor's responsibility to verify the location of all utilities prior to starting construction. Contact J.U.L.I.E., 800-892-0123.
 The soil boring logs represent point information. Presentation of this information in no way implies that subsurface conditions are the same at locations other than the exact location of the boring.
 Undercut shall be paid for at the contract unit price per cubic yard as Removal and Disposal of Unsuitable Material for Structures. If any unsuitable material is noted in addition to the areas shown in the plans during construction with unconfined compressive strength less than 1.5 tsf, the unsuitable soils shall be removed and replaced in accordance with Aggregate Subgrade Improvement Special Provision.
 A cantilevered sheet piling design does not appear feasible and additional members or retention systems may be necessary. The Contractor shall submit a temporary soil retention system design including plan details and calculations for review and acceptance by the Engineer.

INDEX OF SHEETS

- SA-01 General Plan and Elevation - 1
- SA-02 General Plan and elevation - 2
- SA-03 General Notes, Bill of material and TSRS
- SA-04 Typical Cross Section
- SA-05 West Wall Elevation - 1
- SA-06 West Wall Elevation - 2
- SA-07 East Wall Elevation
- SA-08 Wall Details
- SA-09 Form Liner Details
- SA-10 Bicycle Railing
- SA-11 Soil Boring Logs - 1
- SA-12 Soil Boring Logs - 2
- SA-13 Soil Boring Logs - 3

TOTAL BILL OF MATERIAL

ITEM	UNIT	QUANTITY
Porous Granular Backfill	Cu. Yd.	356
Aggregate Subgrade Improvement	Cu. Yd.	146
Structure Excavation	Cu. Yd.	1,101
Removal and Disposal of Unsuitable Material for Structures	Cu. Yd.	146
Reinforcement Bars, Epoxy Coated	Pound	43,180
Bicycle Railing	Foot	361
Temporary Soil Retention System	Sq. Ft.	5,895
Concrete Structures (Retaining Wall)	Cu. Yd.	400
Geocomposite Wall Drain	Sq. Yd.	268
Pipe Underdrains for Structures 4"	Foot	401
Concrete Surface Color Treatment	Sq. Ft.	1,972
Anti-Graffiti Coating	Sq. Ft.	1,972
Form Liner Textured Surface, Special	Sq. Ft.	1,746

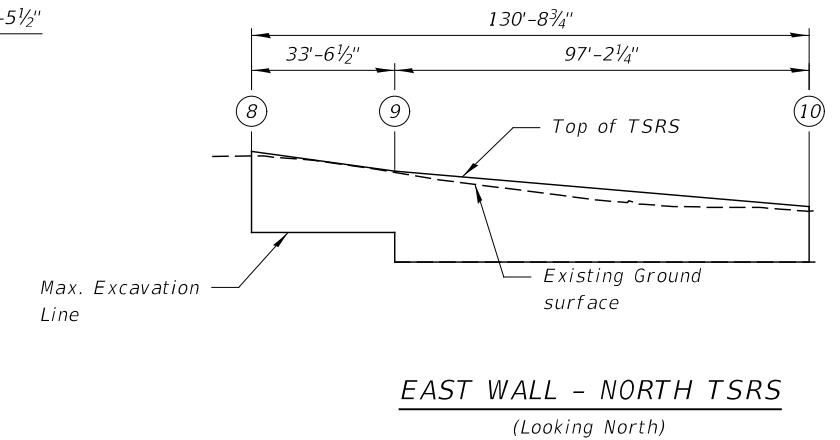
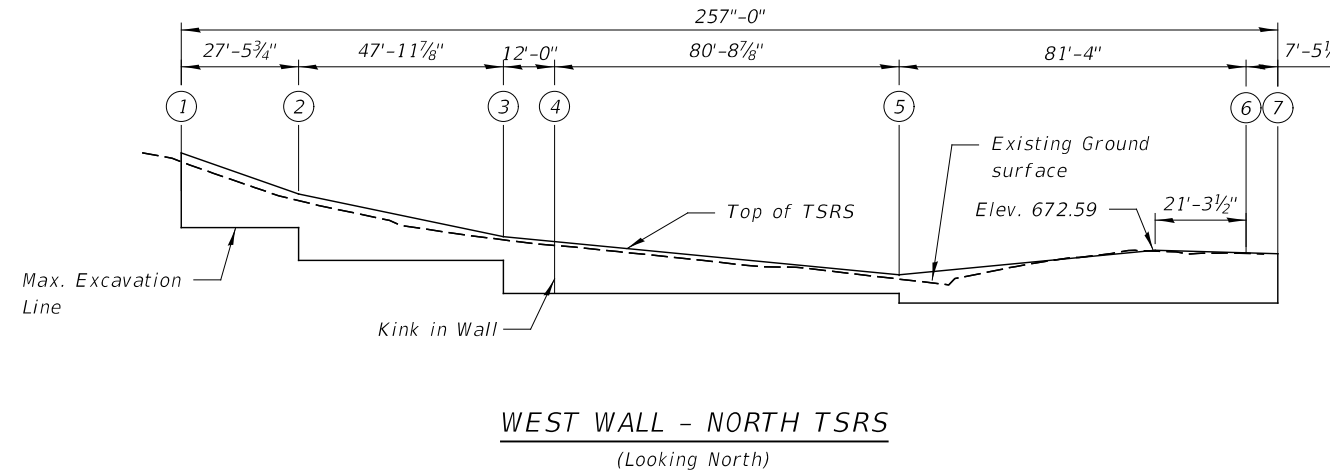

TSRS ELEVATIONS

Mark	Station	Offset	T/TSRS	B/Excavation Elev.
1	212+74.93	47.27	684.01	675.24
2	213+01.05	47.57	679.18	671.39
3	213+49.00	49.16	674.18	667.53
4	213+61.01	49.56	673.60	667.53
5	214+41.86	49.88	669.71	666.41
6	215+23.09	50.27	672.30	666.41
7	215+31.74	59.56	672.20	666.41
8	216+07.07	49.50	673.81	664.29
9	216+40.61	49.50	671.50	660.83
10	217+37.80	49.50	667.35	660.83
11	212+74.99	33.21	684.01	675.24
12	212+99.51	33.62	682.87	671.39
13	213+49.51	34.16	680.64	667.53
14	213+62.68	34.63	680.03	667.53
15	214+41.93	34.90	676.48	666.41
16	214+27.90	35.37	672.64	666.41
17	215+31.74	49.94	672.49	666.41
18	216+07.14	40.50	671.08	664.29
19	216+39.01	40.50	670.19	660.83
20	217+37.80	38.00	667.35	660.83

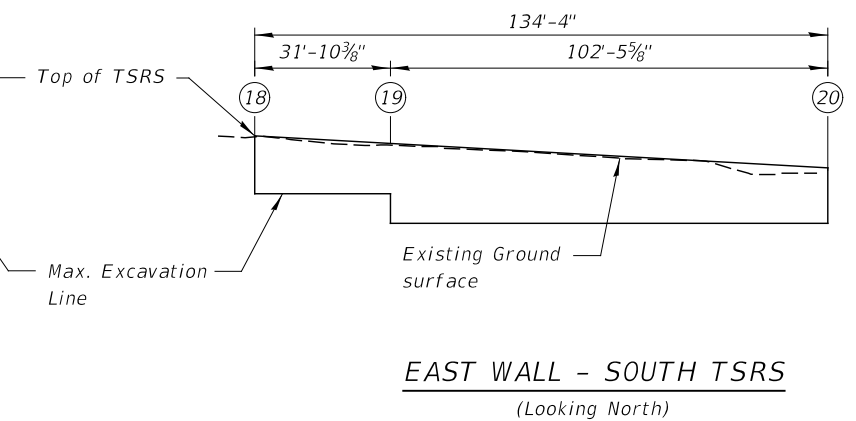
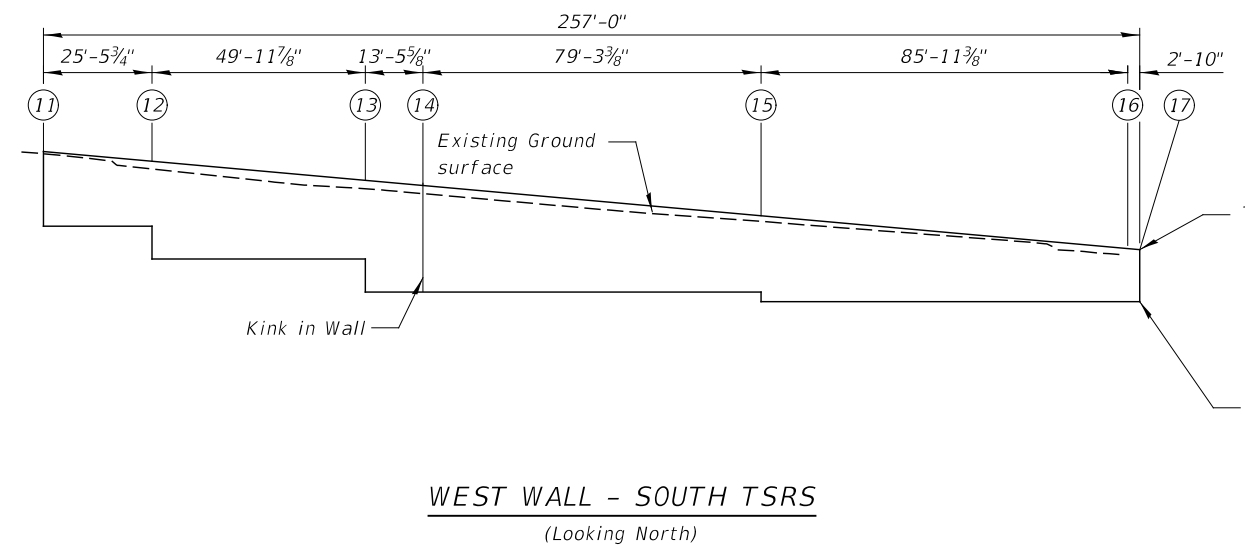

PLOT DATE = 2/9/2024



DESIGNED - NR	REVISION
CHECKED - MS	REVISION
SCALE - NONE	REVISION
DATE - 2/9/2024	REVISION
DRAWN - MN	REVISION
CHECKED - MS	REVISION

STATE OF ILLINOIS
DEPARTMENT OF TRANSPORTATION

GENERAL NOTES, BILL OF MATERIAL AND TSRS
EAST & WEST RETAINING WALLS

SHEET SA-03 OF 13 SHEETS

F.A.U. RTE.	SECTION	COUNTY	TOTAL SHEETS	SHEET NO.
1479	14-00124-00-BR	DUPAGE	208	157
CONTRACT NO. 61J14				
ILLINOIS FED. AID PROJECT				

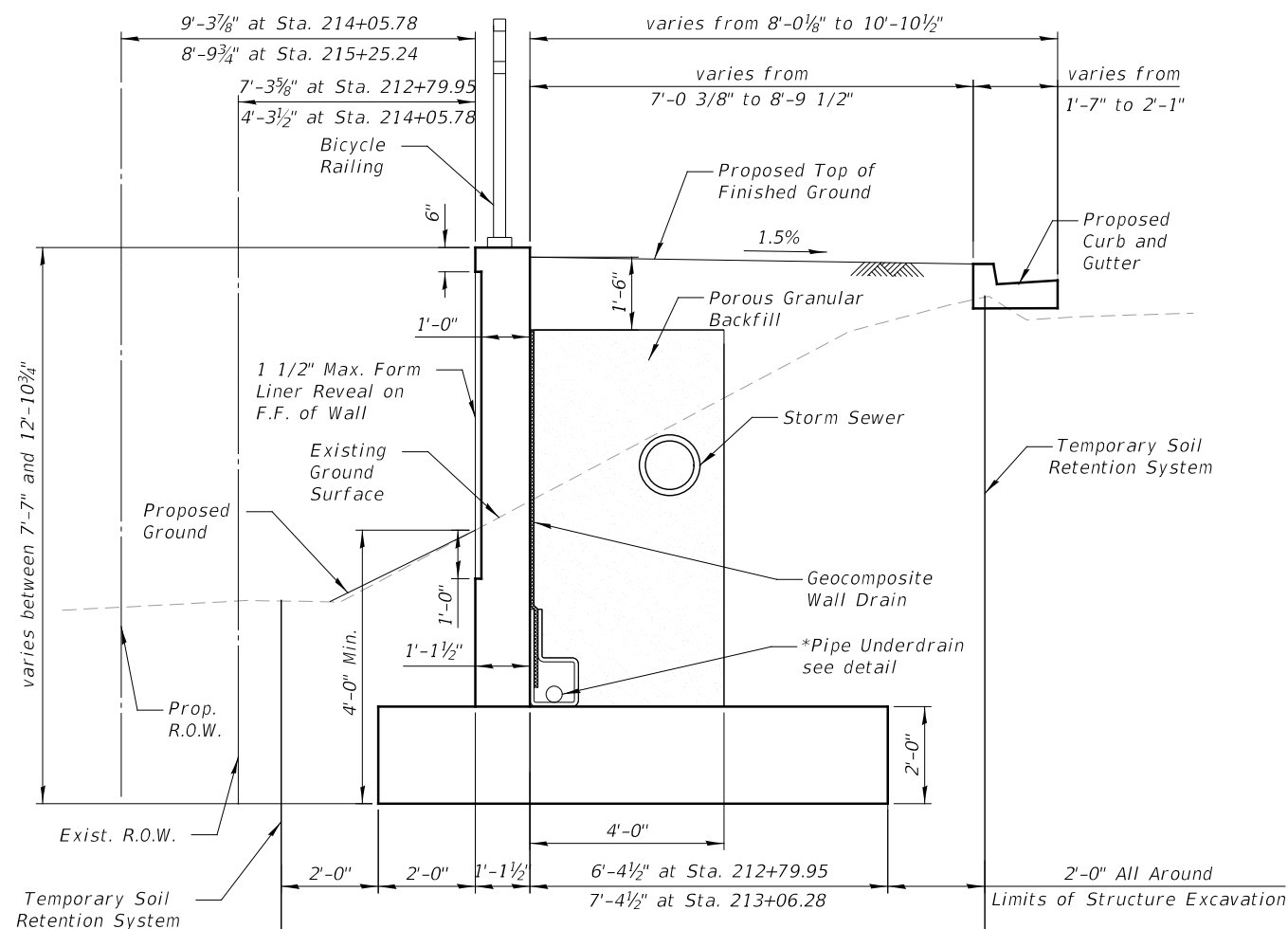

TYPICAL SECTION THRU WEST WALL

(from Sta. 212+79.95 to 215+25.24)

* Connect to Drainage Structure S-2

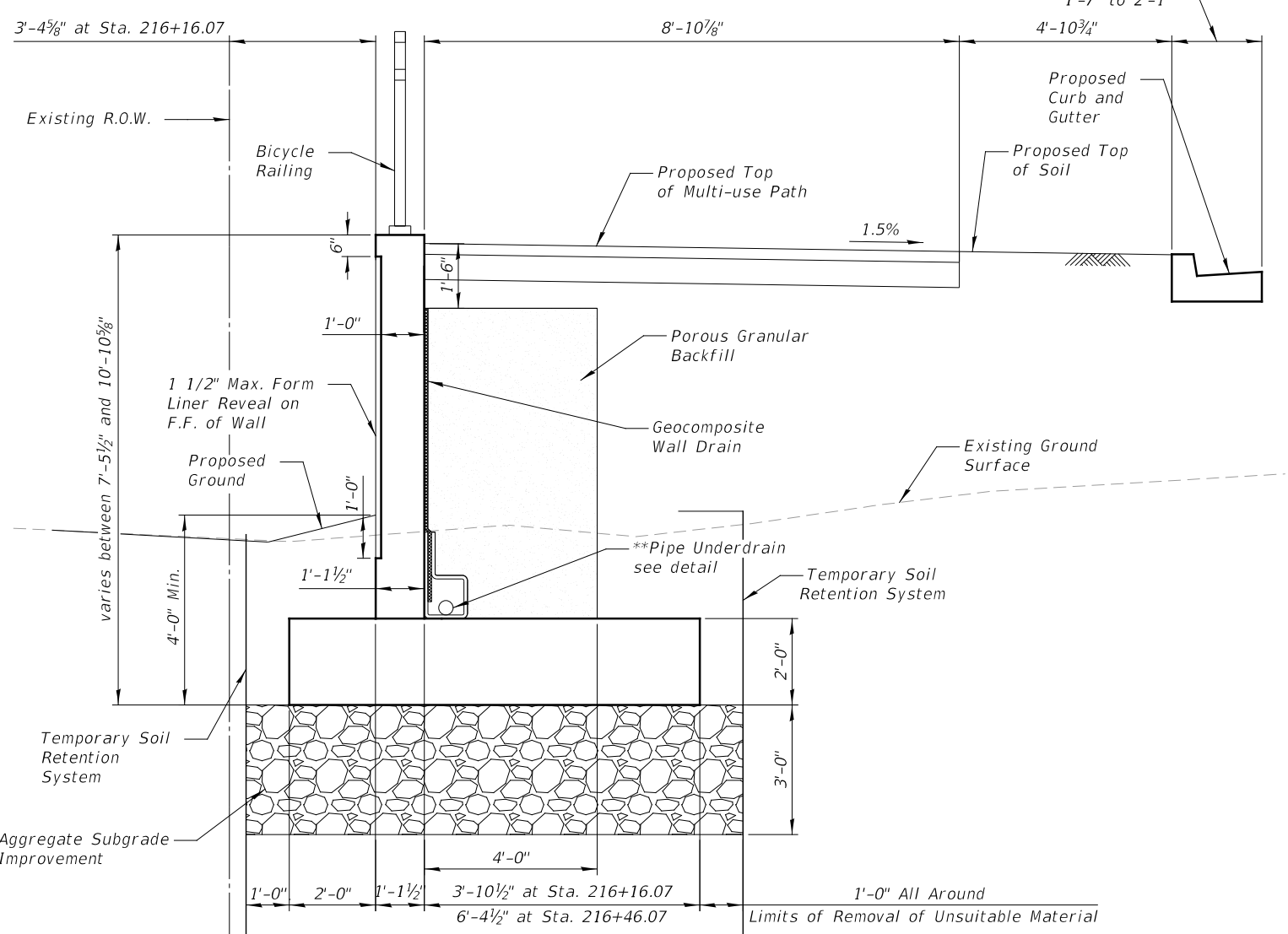

TYPICAL SECTION THRU EAST WALL

(from Sta. 216+16.07 to 217+30.30)

** Connect to Drainage Structure S-4

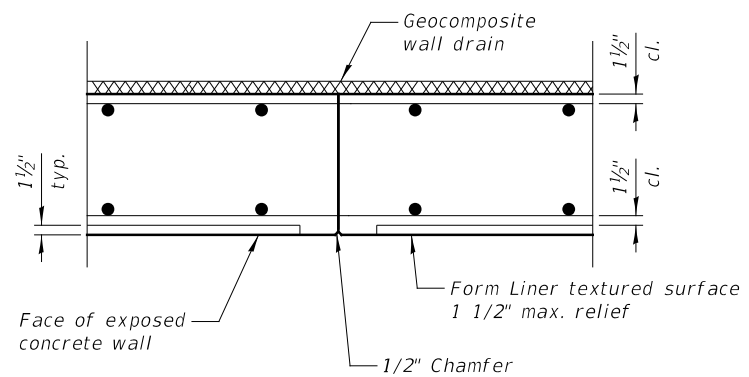

CONSTRUCTION JOINT DETAIL

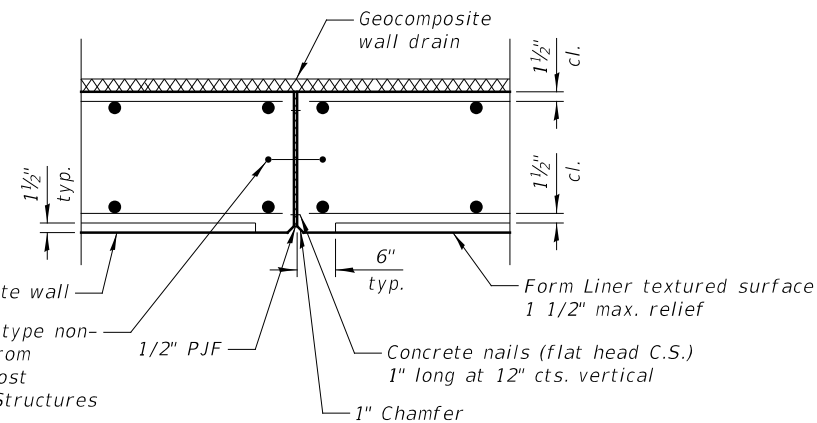

EXPANSION JOINT DETAIL

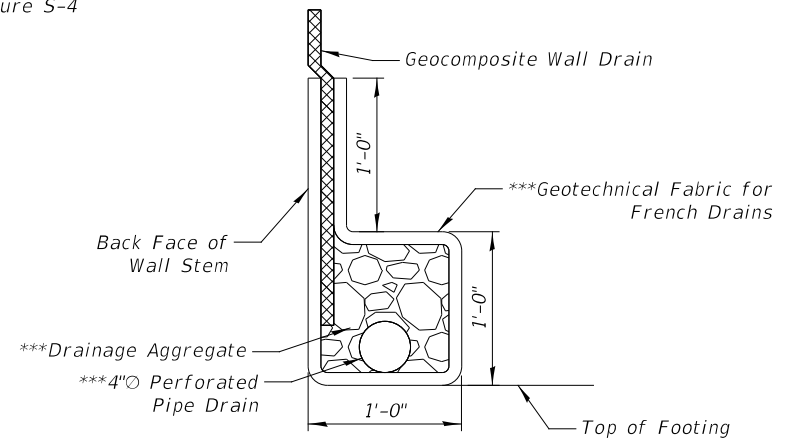

PIPE UNDERDRAIN DETAIL

***Included in the cost of "Pipe Underdrains for Structures 4"

PLOT DATE = 2/9/2024



DESIGNED	-	NR	REVISED
CHECKED	-	MS	REVISED
SCALE	-	NONE	REVISED
DATE	-	2/9/2024	REVISED
DRAWN	-	MN	
CHECKED	-	MS	

DESIGNED	-	NR	REVISED
CHECKED	-	MS	REVISED
DRAWN	-	MN	REVISED
CHECKED	-	MS	REVISED

DESIGNED	-	NR	REVISED
CHECKED	-	MS	REVISED
DRAWN	-	MN	REVISED
CHECKED	-	MS	REVISED

STATE OF ILLINOIS
DEPARTMENT OF TRANSPORTATION

TYPICAL CROSS SECTIONS
EAST & WEST RETAINING WALLS

SHEET SA-04 OF 13 SHEETS

F.A.U. RTE.	SECTION	COUNTY	TOTAL SHEETS	SHEET NO.
1479	14-00124-00-BR	DUPAGE	208	158
CONTRACT NO. 61J14				
ILLINOIS FED. AID PROJECT				

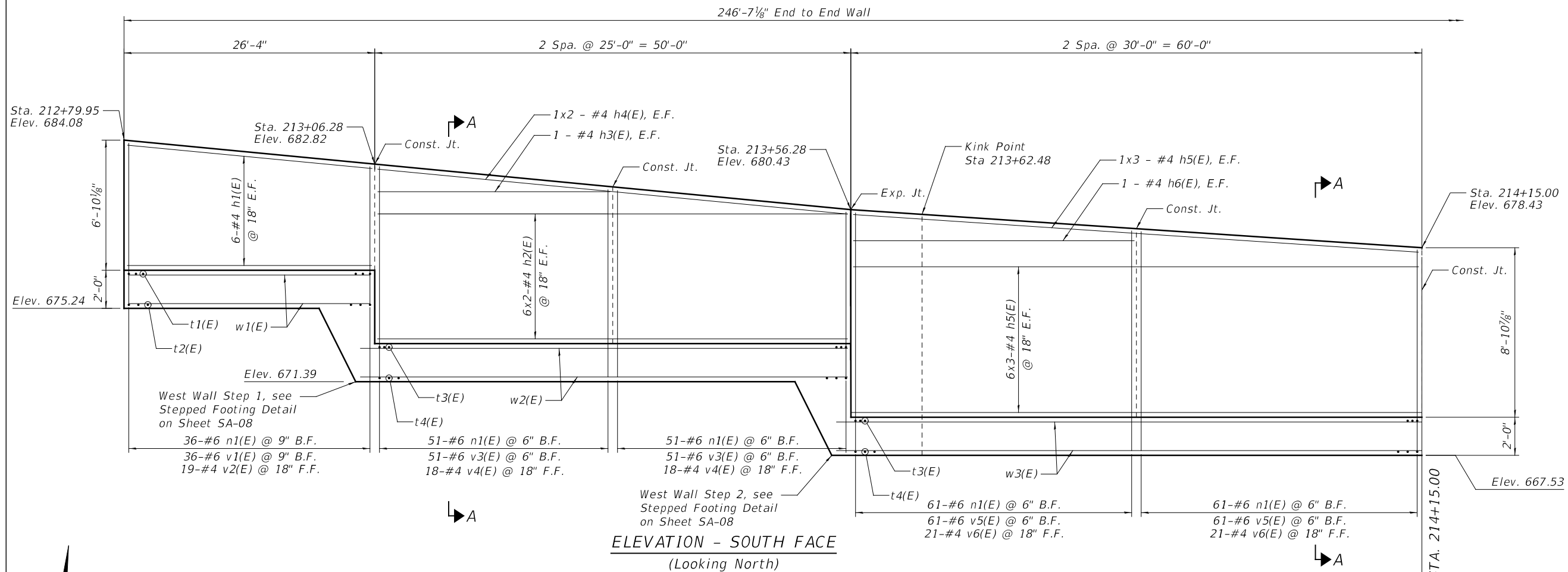

ELEVATION - SOUTH FACE
(Looking North)

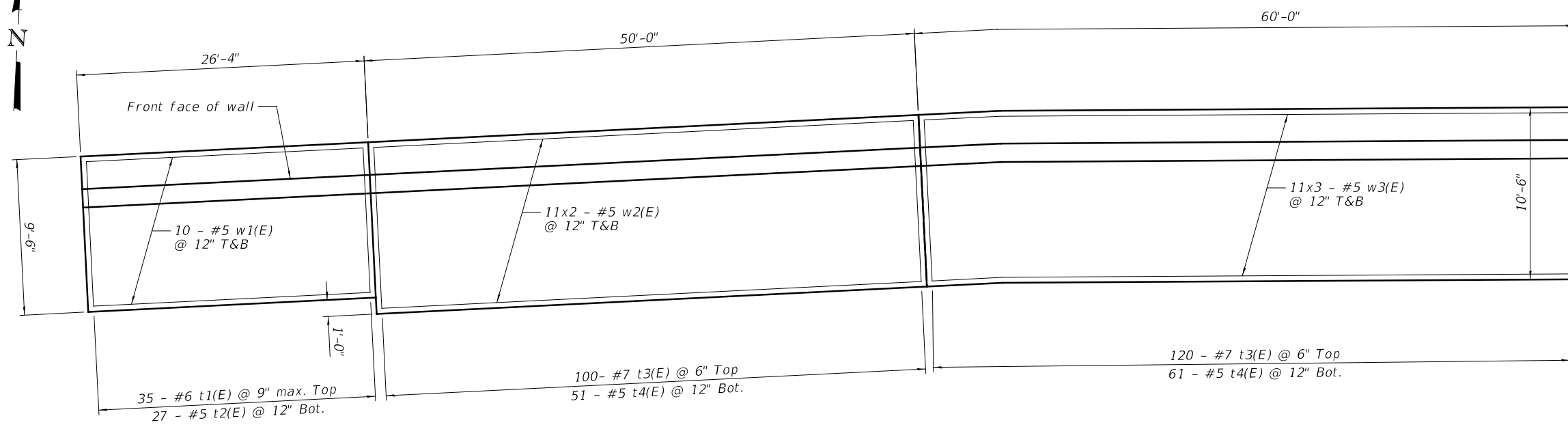

FOOTING PLAN

LEGEND
 E.F. Each Face
 B.F. Back Face
 F.F. Front Face
 T&B Top and Bottom

Min. Bar Laps
 #4 Bars = 2'-11" (Horiz. Top Bars)
 #5 Bars = 3'-2"

Notes:
 All dimensions are along front face of wall.
 See sheet SA-08 for Section A-A.

PLOT DATE = 2/9/2024



DESIGNED - NR	REVISION
CHECKED - MS	REVISION
DRAWN - MN	REVISION
CHECKED - MS	REVISION
SCALE - NONE	
DATE - 2/9/2024	

STATE OF ILLINOIS
DEPARTMENT OF TRANSPORTATION

PLAN AND ELEVATION - 1
WEST RETAINING WALL
SHEET SA-05 OF 13 SHEETS

F.A.U. RTE.	SECTION	COUNTY	TOTAL SHEETS	SHEET NO.
1479	14-00124-00-BR	DUPAGE	208	159
CONTRACT NO. 61J14				
ILLINOIS FED. AID PROJECT				

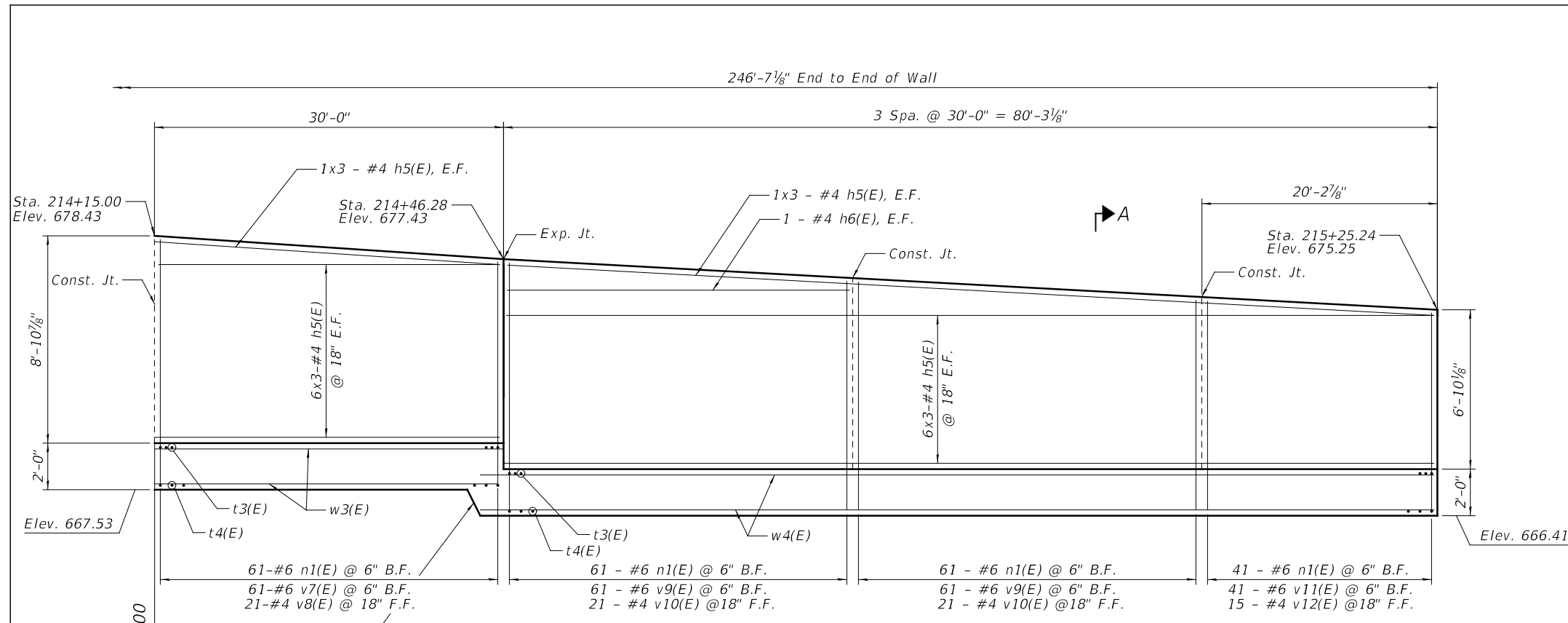

ELEVATION - SOUTH FACE
(Looking North)

MATCHLINE STA. 214+15.00

West Wall Step 3, see Stepped Footing Detail on Sheet SA-08

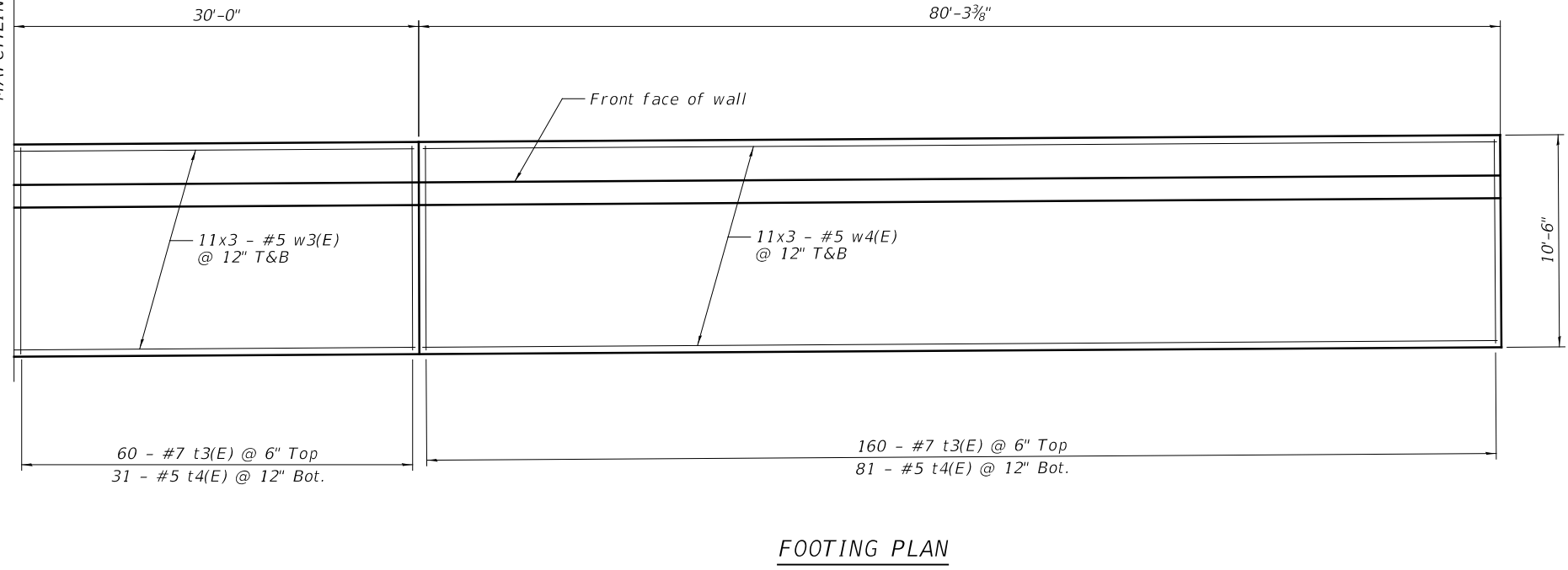

FOOTING PLAN

LEGEND
E.F. Each Face
B.F. Back Face
F.F. Front Face
T&B Top and Bottom

Min. Bar Laps
#4 Bars = 2'-11" (Horiz. Top Bars)
#5 Bars = 3'-2"

Notes:
All dimensions are along front face of wall.
See sheet SA-08 for Section A-A.

PLOT DATE = 2/9/2024

KNIGHT
Member of WSP

DESIGNED - NR	REVIS
CHECKED - MS	REVIS
SCALE - NONE	REVIS
DATE - 2/9/2024	REVIS

STATE OF ILLINOIS
DEPARTMENT OF TRANSPORTATION

PLAN AND ELEVATION - 2
WEST RETAINING WALL

SHEET SA-06 OF 13 SHEETS

F.A.U. RTE.	SECTION	COUNTY	TOTAL SHEETS	SHEET NO.
1479	14-00124-00-BR	DUPAGE	208	160
CONTRACT NO. 61J14				
ILLINOIS FED. AID PROJECT				

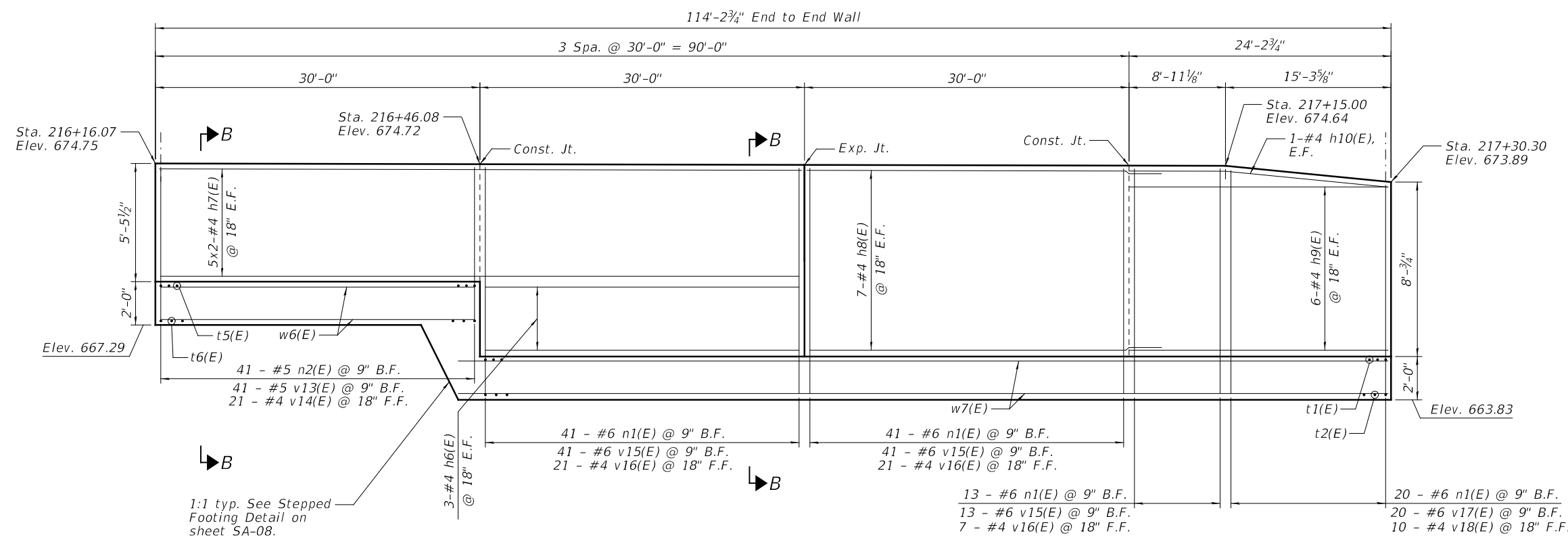

ELEVATION - SOUTH FACE
(Looking North)

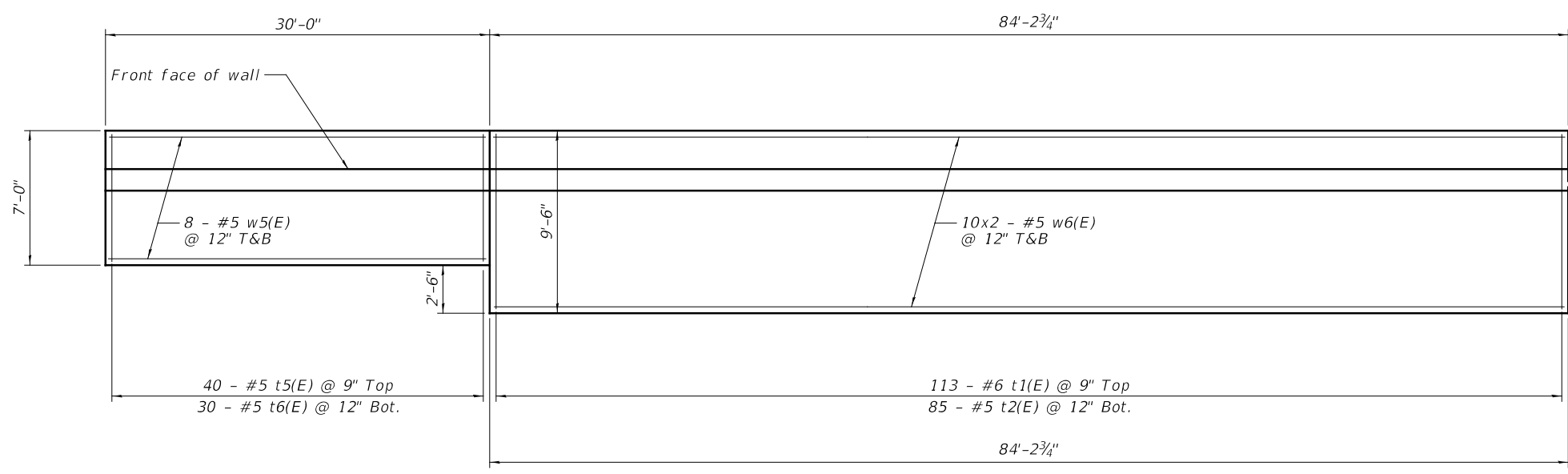

FOOTING PLAN

LEGEND

- E.F. Each Face
- B.F. Back Face
- F.F. Front Face
- T&B Top and Bottom

Min. Bar Laps

- #4 Bars = 2'-11" (Horiz. Top Bars)
- #5 Bars = 3'-2"

Notes:
All dimensions are along front face of wall.
See sheet SA-08 for Section B-B.

PLOT DATE = 2/9/2024



DESIGNED	-	NR	REVISED	
CHECKED	-	MS	REVISED	
SCALE	-	NONE	REVISED	
DATE	-	2/9/2024	REVISED	

DESIGNED	-	NR	REVISED	
CHECKED	-	MS	REVISED	
DRAWN	-	MN	REVISED	
CHECKED	-	MS	REVISED	

DESIGNED	-	NR	REVISED	
CHECKED	-	MS	REVISED	
DRAWN	-	MN	REVISED	
CHECKED	-	MS	REVISED	

STATE OF ILLINOIS
DEPARTMENT OF TRANSPORTATION

PLAN AND ELEVATION
EAST RETAINING WALL

SHEET SA-07 OF 13 SHEETS

F.A.U. RTE.	SECTION	COUNTY	TOTAL SHEETS	SHEET NO.
1479	14-00124-00-BR	DUPAGE	208	161
CONTRACT NO. 61J14				
ILLINOIS FED. AID PROJECT				

BILL OF MATERIAL

Bar	No.	Size	Length	Shape
h1(E)	12	#4	25'-10"	---
h2(E)	24	#4	26'-3"	---
h3(E)	2	#4	24'-8"	---
h4(E)	4	#4	26'-3"	---
h5(E)	84	#4	32'-11"	---
h6(E)	10	#4	29'-8"	---
h7(E)	20	#4	31'-3"	---
h8(E)	14	#4	32'-9"	---
h9(E)	12	#4	24'-1"	---
h10(E)	2	#4	23'-11"	---
n1(E)	599	#6	6'-3"	---
n2(E)	41	#5	5'-6"	---
t1(E)	148	#6	9'-2"	---
t2(E)	116	#5	9'-2"	---
t3(E)	440	#7	10'-2"	---
t4(E)	234	#5	10'-2"	---
t5(E)	40	#5	6'-6"	---
t6(E)	36	#5	6'-6"	---
t7(E)	21	#5	14'-0"	---
t8(E)	21	#5	7'-1"	---
t9(E)	11	#5	10'-0"	---
t10(E)	11	#5	4'-4"	---
t11(E)	8	#5	13'-5"	---
t12(E)	8	#5	6'-8"	---
v1(E)	18	#6	11'-9"	---
v2(E)	10	#4	11'-9"	---
v3(E)	51	#6	15'-10"	---
v4(E)	18	#4	15'-10"	---
v5(E)	61	#6	19'-2"	---
v6(E)	21	#4	19'-2"	---
v7(E)	31	#6	16'-2"	---
v8(E)	11	#4	16'-2"	---
v9(E)	61	#6	15'-8"	---
v10(E)	21	#4	15'-8"	---
v11(E)	21	#6	13'-6"	---
v12(E)	8	#4	13'-6"	---
v13(E)	41	#5	5'-1"	---
v14(E)	21	#4	5'-1"	---
v15(E)	95	#6	8'-6"	---
v16(E)	49	#4	8'-6"	---
v17(E)	10	#6	16'-2"	---
v18(E)	5	#4	16'-2"	---
w1(E)	20	#5	25'-10"	---
w2(E)	44	#5	26'-4"	---
w3(E)	66	#5	33'-2"	---
w4(E)	66	#5	28'-10"	---
w5(E)	16	#5	29'-6"	---
w6(E)	60	#5	30'-2"	---
Reinforcement Bars, Epoxy Coated	Pound	43,180		
Concrete Structures, (Retaining wall)	Cu. Yd.	400		
Geocomposite Wall Drain	Sq. Yd.	268		
Pipe Underdrains for Structures 4"	Foot	401		
Concrete Surface Color Treatment	Sq. Ft.	1,972		
Form Liner Textured Surface, Special	Sq. Ft.	1,746		

Notes:
 1. Reinforcement bars designated (E) shall be epoxy coated.
 2. Bars indicated thus 1x2 #5 etc indicates 1 line of bars with 2 lengths per line.

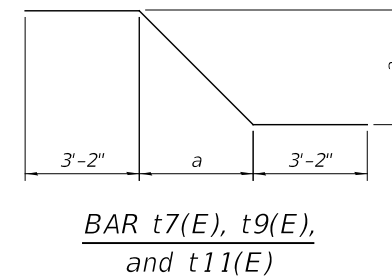
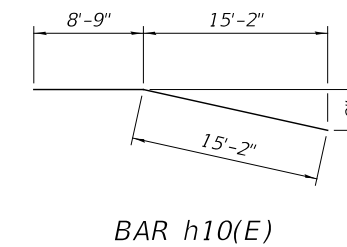
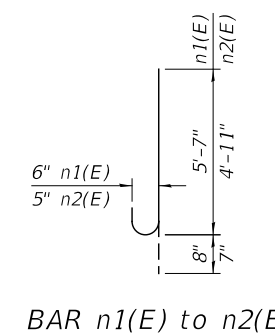
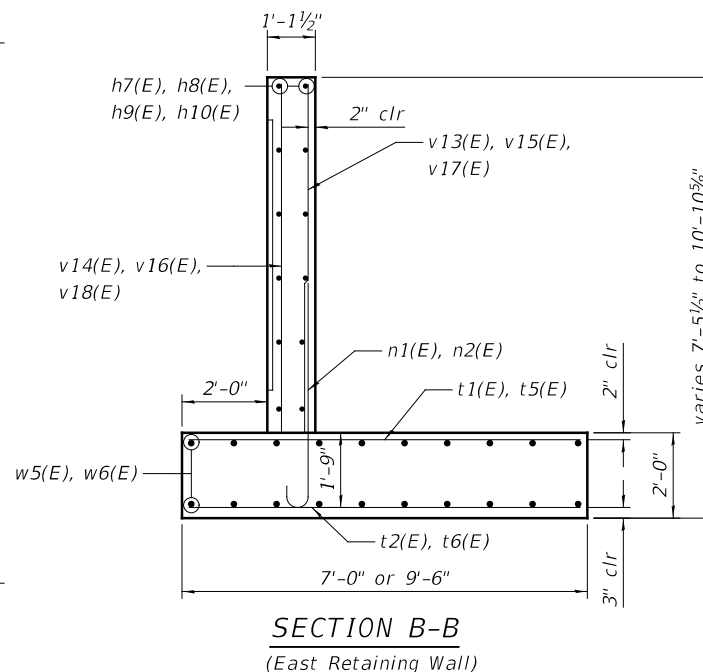
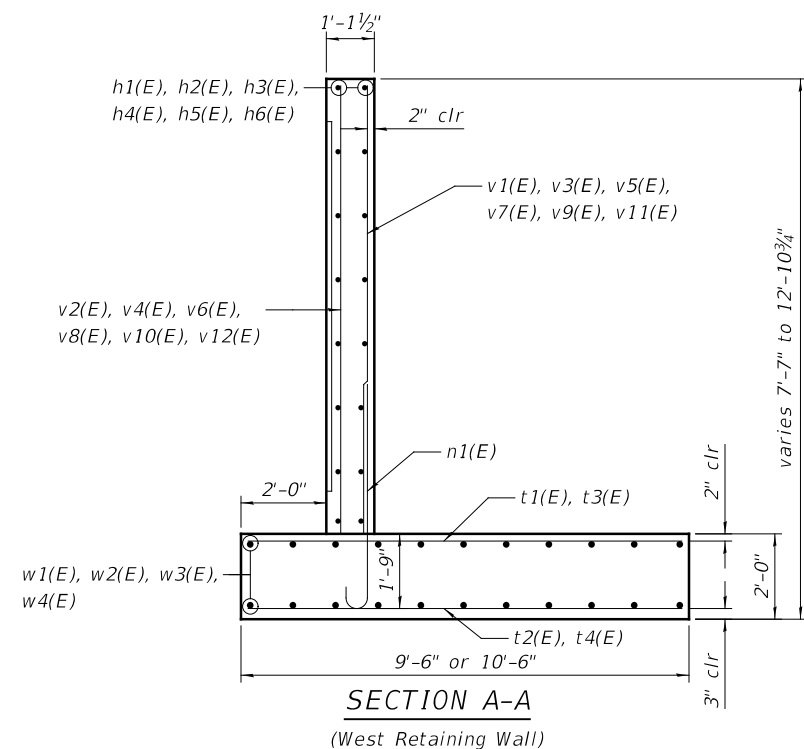

Bar	a
t7(E)	5'-5"
t9(E)	2'-8"
t11(E)	5'-0"

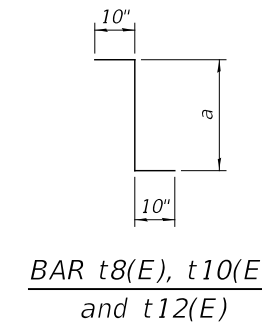

Bar	a
t8(E)	5'-5"
t10(E)	2'-8"
t12(E)	5'-0"

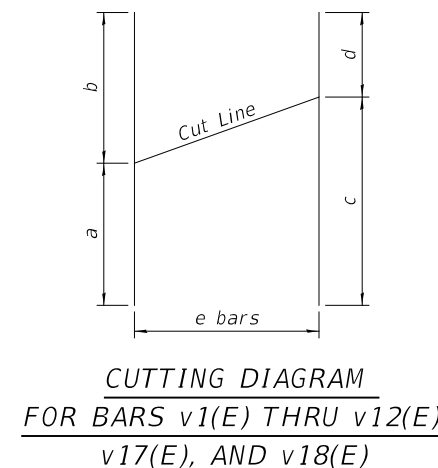
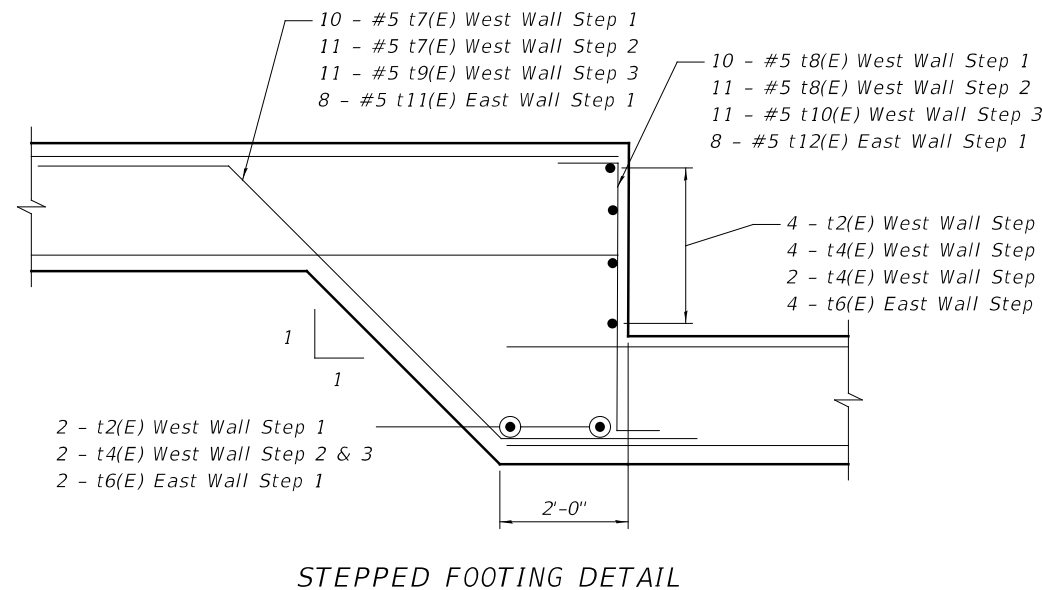

Bar	a	b	c	d	e
v1(E)	6'-6"	5'-3"	5'-11"	5'-11"	18
v2(E)	6'-6"	5'-3"	5'-11"	5'-11"	10
v3(E)	9'-1"	6'-9"	7'-11"	7'-11"	51
v4(E)	9'-1"	6'-9"	7'-11"	7'-11"	18
v5(E)	10'-7"	8'-7"	9'-7"	9'-7"	61
v6(E)	10'-7"	8'-7"	9'-7"	9'-7"	21
v7(E)	8'-7"	7'-7"	8'-1"	8'-1"	31
v8(E)	8'-7"	7'-7"	8'-1"	8'-1"	11
v9(E)	8'-8"	7'-0"	7'-10"	7'-10"	61
v10(E)	8'-8"	7'-0"	7'-10"	7'-10"	21
v11(E)	7'-0"	6'-6"	6'-9"	6'-9"	21
v12(E)	7'-0"	6'-6"	6'-9"	6'-9"	8
v17(E)	8'-5"	7'-9"	8'-1"	8'-1"	10
v18(E)	8'-5"	7'-9"	8'-1"	8'-1"	5

PLOT DATE = 2/9/2024



DESIGNED - NR	REVISION
CHECKED - MS	REVISION
SCALE - NONE	REVISION
DATE - 2/9/2024	REVISION
DRAWN - MN	REVISION
CHECKED - MS	REVISION

STATE OF ILLINOIS
DEPARTMENT OF TRANSPORTATION

RETAINING WALL DETAILS
EAST & WEST RETAINING WALLS

SHEET SA-08 OF 13 SHEETS

F.A.U. RTE.	SECTION	COUNTY	TOTAL SHEETS	SHEET NO.
1479	14-00124-00-BR	DUPAGE	208	162
CONTRACT NO. 61J14				
ILLINOIS FED. AID PROJECT				

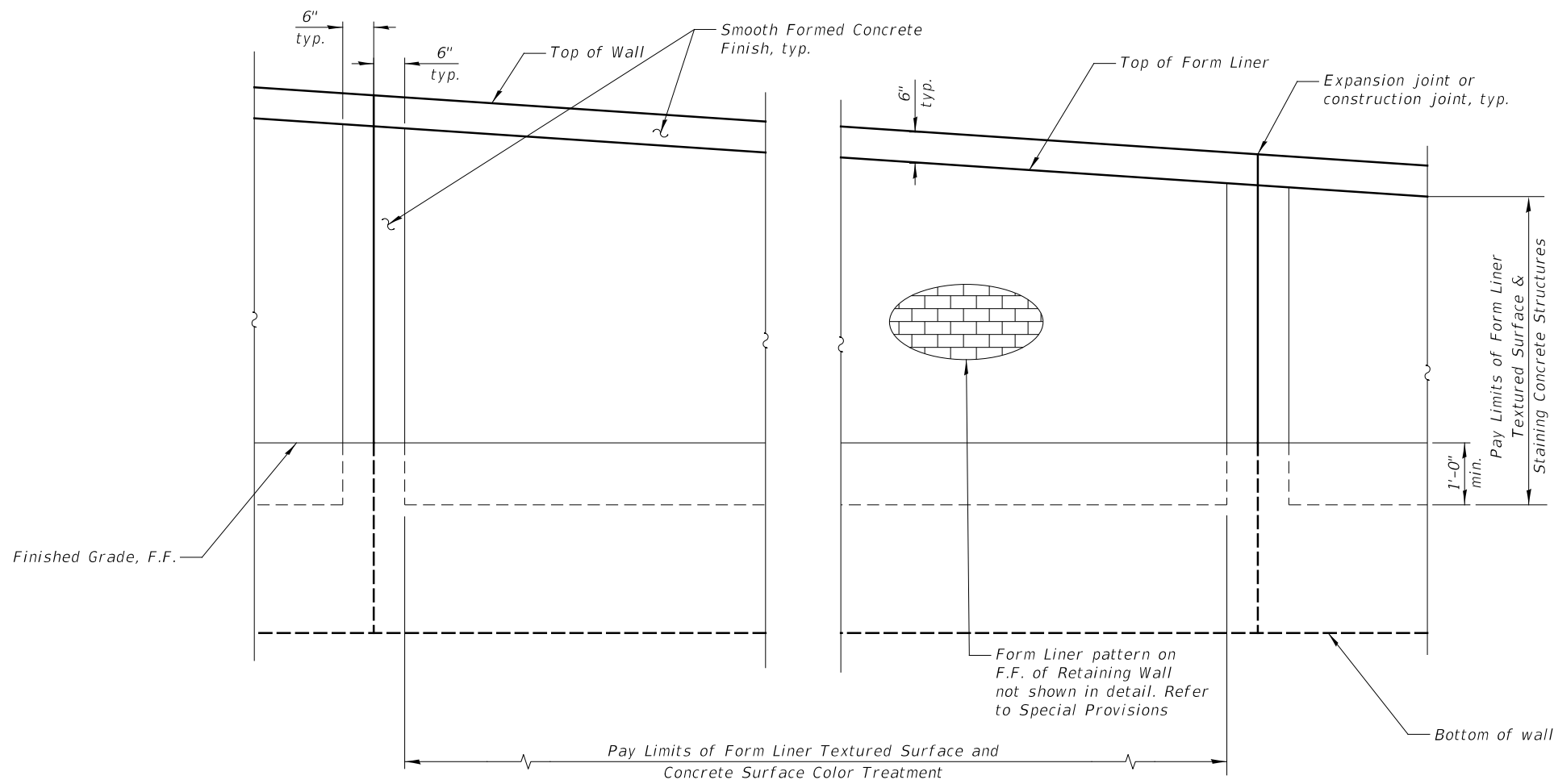

FORM LINER TEXTURED SURFACE DETAIL

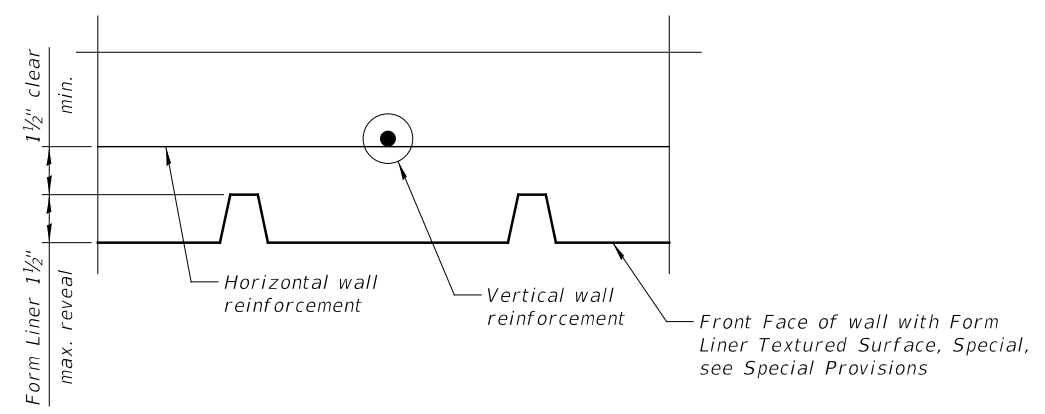

PLAN - FORM LINER

NOTES:

1. The front face of concrete retaining wall shall have an 8" x 16" Split Face block #1407 pattern for the full length of the wall.
2. Top of wall shall be Smooth Formed Concrete to create appearance of Concrete Cap over Formliner Pattern below. See detail for depth from top of wall to where cap transitions to formliner. Formliner pattern shall be cut so that application of Grout Material (per the project Special Provision for Formliner Textured Surface) at the base of cap and start of formliner has the appearance of a Grout Line with natural stone masonry.

PLOT DATE = 2/9/2024

KNIGHT
Member of WSP

DESIGNED - NR	REVIS
CHECKED - MS	REVIS
SCALE - NONE	REVIS
DATE - 2/9/2024	REVIS

STATE OF ILLINOIS
DEPARTMENT OF TRANSPORTATION

**FORM LINER DETAILS
EAST & WEST RETAINING WALLS**

SHEET SA-09 OF 13 SHEETS

F.A.U. RTE.	SECTION	COUNTY	TOTAL SHEETS	SHEET NO.
1479	14-00124-00-BR	DUPAGE	208	163
CONTRACT NO. 61J14				
ILLINOIS FED. AID PROJECT				

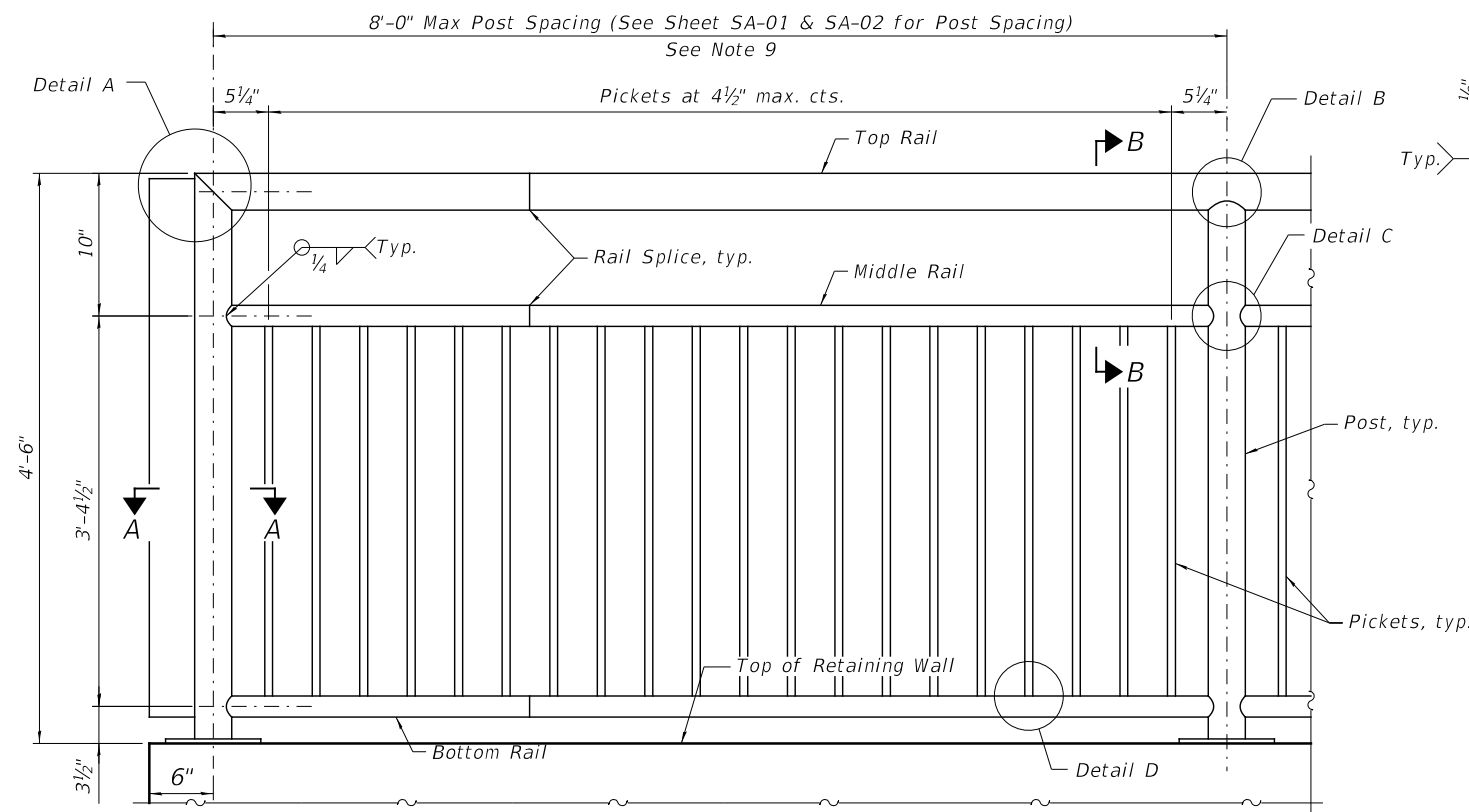

BICYCLE RAILING ELEVATION

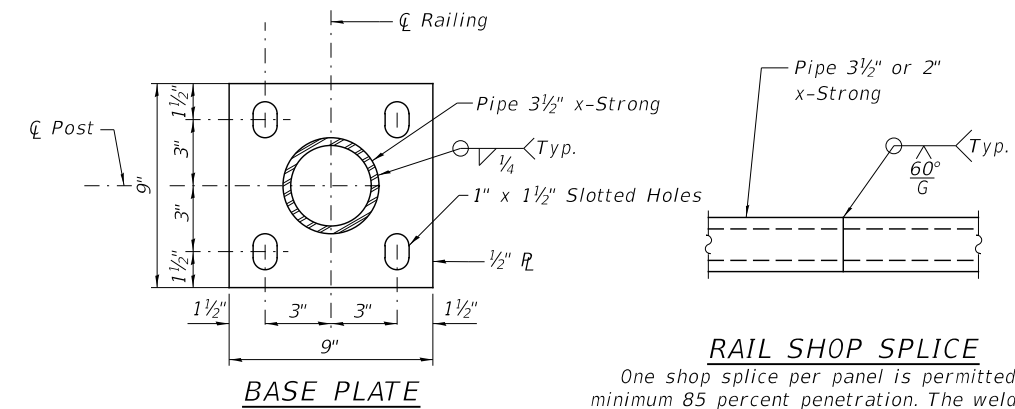
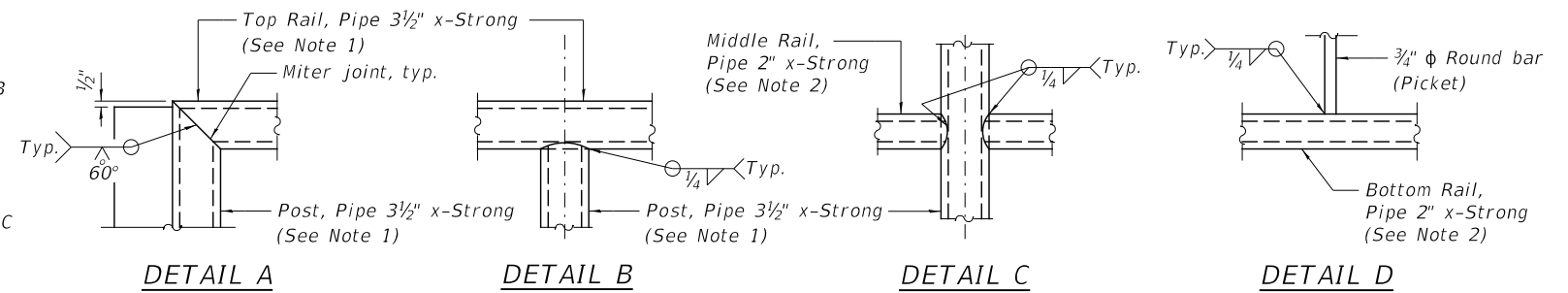

RAIL SHOP SPLICE

One shop splice per panel is permitted with minimum 85 percent penetration. The weld may be square groove or single vee groove. Grind smooth

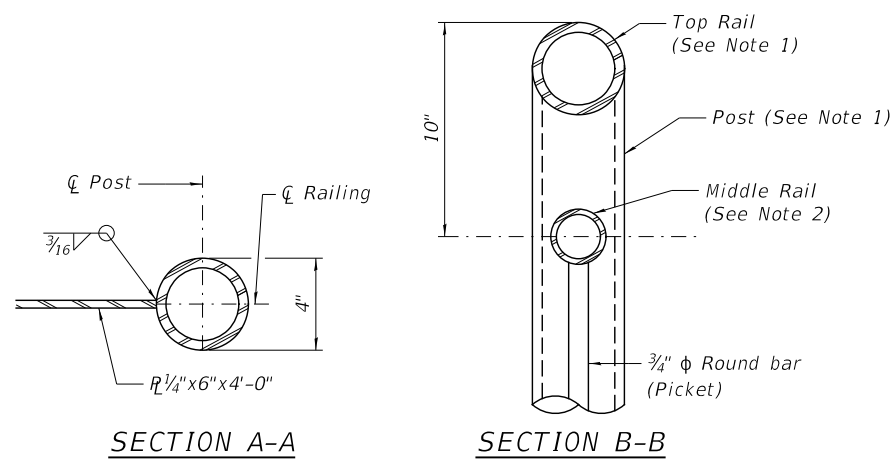

SECTION A-A

SECTION B-B

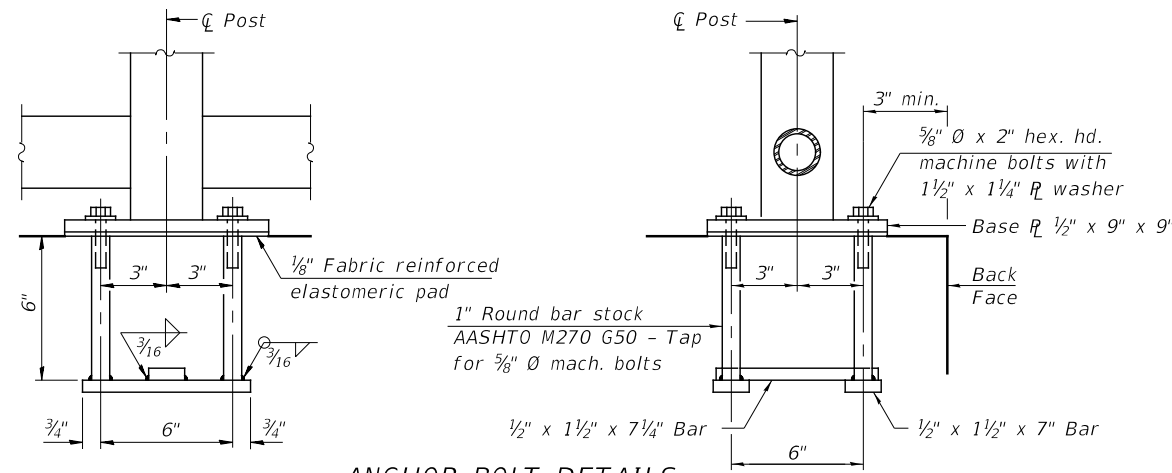

ANCHOR BOLT DETAILS

In lieu of the cast-in-place anchor device shown, the Contractor has the option of drilling and setting 3/8" Ø anchor rods according to Article 509.06 of the Standard Specifications. Embedment shall be according to the manufacturer's specifications.

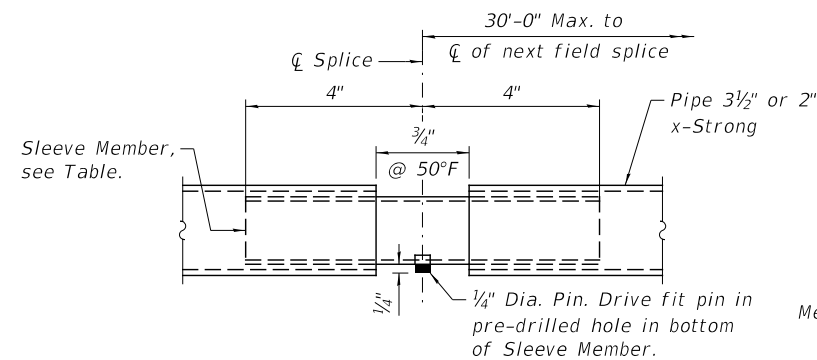

RAIL FIELD SPLICE

SLEEVE MEMBER

Rail Size	Sleeve Member
3 1/2" x-Strong	3/4" Ø MT Pipe (3/4" O.D., 0.120" wall thickness)
2" x-Strong	1 13/16" Ø MT Pipe (1 13/16" O.D., 0.120" wall thickness)

Mechanical tubing (MT) will conform to ASTM A513 Grade 1015 or higher.

Notes:

1. Use Pipe 3 1/2" x-Strong (4" O.D., 0.318" wall thickness) for posts and top rail. Provide holes as needed in post and top rail for powder coating drainage and hanging. Plumb all posts.
2. Use 2" Ø x-Strong Pipe (2.380" O.D., 0.218" wall thickness) for middle and bottom rails. Parallel to top of retaining wall. Provide holes as needed for powder coating drainage and hanging.
3. Pipe will conform to ASTM-A53 Grade B. Steel plates and steel bars will conform to AASHTO M270 Gr. 50.
4. All rail elements shall be powder coated according to ASTM D7803.
5. Railing and any wall or other surface adjacent to them shall be free of any sharp or abrasive elements.
6. Submit shop drawings to the Engineer unless noted otherwise.
7. For all railings, erection drawings shall be submitted for approval to ensure proper installation. Drawings shall show field splice locations, railing expansion joints (placed at the existing joint locations in the reinforced concrete wall), post spacing, anchor bolt drilling and setting procedures, profile slope, splice joint locations, shim plates, and railing lengths with identification showing where each railing goes on the layout.
8. Railing shall be fabricated such that longitudinal elements are parallel to the top of sidewalk and posts are plumb. Contractor shall field verify sidewalk profile slope.
9. All exposed edges will be rounded or chamfered to approximately 1/8" by grinding.

BILL OF MATERIAL

Item	Unit	Quantity
Bicycle Railing	Foot	405

PLOT DATE = 2/9/2024



DESIGNED - NR	REVISIONS
CHECKED - MS	REVISIONS
SCALE - NONE	REVISIONS
DATE - 2/9/2024	REVISIONS

DRAWN - MN	REVISIONS
CHECKED - MS	REVISIONS

STATE OF ILLINOIS
DEPARTMENT OF TRANSPORTATION

**BICYCLE RAILING
EAST & WEST RETAINING WALLS**

SHEET SA-10 OF 13 SHEETS

F.A.U. RTE.	SECTION	COUNTY	TOTAL SHEETS	SHEET NO.
1479	14-00124-00-BR	DUPAGE	208	164
CONTRACT NO. 61J14				
ILLINOIS FED. AID PROJECT				



SOIL BORING LOG

Date 8/1/22

ROUTE Warrenville Rd. DESCRIPTION Warrenville Rd. Retaining Walls LOGGED BY Sponaugle

SECTION LOCATION 1872905.433, 1052308.770

COUNTY DuPage DRILLING METHOD Hollow Stem Auger HAMMER TYPE D50 Auto (84% efficiency)

Table with columns for DEPTH (ft), BULGE (in), UCS (tsf), MOISTURE (%), and SOIL DESCRIPTION. Includes data for borings SB-01 and SB-02 with soil types like ASPHALT, SILTY LOAM, and SAND.

The Unconfined Compressive Strength (UCS) Failure Mode is indicated by (B-Bulge, S-Shear, P-Penetrometer)

BBS, from 137 (Rev. 8-99)



SOIL BORING LOG

Date 8/1/22

ROUTE Warrenville Rd. DESCRIPTION Warrenville Rd. Retaining Walls LOGGED BY Sponaugle

SECTION LOCATION 1872908.901, 1052381.501

COUNTY DuPage DRILLING METHOD Hollow Stem Auger HAMMER TYPE D50 Auto (84% efficiency)

Table with columns for DEPTH (ft), BULGE (in), UCS (tsf), MOISTURE (%), and SOIL DESCRIPTION. Includes data for borings SB-02 and SB-03 with soil types like ASPHALT, LOAM, and CLAY.

The Unconfined Compressive Strength (UCS) Failure Mode is indicated by (B-Bulge, S-Shear, P-Penetrometer)

BBS, from 137 (Rev. 8-99)



SOIL BORING LOG

Date 8/1/22

ROUTE Warrenville Rd. DESCRIPTION Warrenville Rd. Retaining Walls LOGGED BY Sponaugle

SECTION LOCATION 1872911.690, 1052454.728

COUNTY DuPage DRILLING METHOD Hollow Stem Auger HAMMER TYPE D50 Auto (84% efficiency)

Table with columns for DEPTH (ft), BULGE (in), UCS (tsf), MOISTURE (%), and SOIL DESCRIPTION. Includes data for borings SB-03 and SB-04 with soil types like ASPHALT, SANDY CLAY LOAM, and SILT.

The Unconfined Compressive Strength (UCS) Failure Mode is indicated by (B-Bulge, S-Shear, P-Penetrometer)

BBS, from 137 (Rev. 8-99)



Table with columns for DESIGNED, CHECKED, DRAWN, and REVISIONS.

STATE OF ILLINOIS DEPARTMENT OF TRANSPORTATION

BORING LOGS - 1 EAST & WEST RETAINING WALLS

Table with columns for F.A.U. RTE., SECTION, COUNTY, TOTAL SHEETS, SHEET NO., and CONTRACT NO.



SOIL BORING LOG

Page 1 of 1

Date 8/1/22

ROUTE Warrenville Rd. DESCRIPTION Warrenville Rd. Retaining Walls LOGGED BY Sponaugle

SECTION LOCATION 1872913.394,1052525.524

COUNTY DuPage DRILLING METHOD Hollow Stem Auger HAMMER TYPE D50 Auto (84% efficiency)

STRUCT. NO. Station	DEPTH H	BLOW S	UCS Qu	MOIST T	Surface Water Elev. _____ ft				DEPTH H	BLOW S	UCS Qu	MOIST T
					Stream Bed Elev. _____ ft							
BORING NO. SB-04 Station 215+17 Offset 26.30ft LT Ground Surface Elev. 673.00 ft					Groundwater Elev.: First Encounter 654.5 ft Upon Completion 649.8 ft After _____ Hrs. Not taken ft							
ASPHALT (8")	0	672.30			Loose, gray, moist SILT (continued)				0	652.50		
Stiff, black with green mottling, moist SILTY CLAY, trace coarse to fine sand, low plasticity	2				Very stiff, gray, moist SILTY CLAY, low plasticity				4		21.5	
	5		23.5						4			
	5	1.4							6	2.3		
Very stiff, trace fine gravel	2				Very stiff				4		22.3	
	3		21.4						6			
	4	2.9			End of boring at 25'				7	2.1		
Collected Shelby tube 6-8'												
Very stiff	2											
	4		27.6									
	5	2.3										
Medium stiff, green with black mottling, medium plasticity	1		59.7									
	2	0.9										
Medium dense, brown, moist coarse to fine SANDY LOAM, some fine gravel	5		10.9									
	10											
	10											
Loose, gray, moist SILT sand seams at 16.3' and 16.8'	4		24.6									
	3											
	4											
Loose, trace clay	3		22.4									
	4											
	5											

The Unconfined Compressive Strength (UCS) Failure Mode is indicated by (B-Bulge, S-Shear, P-Penetrometer)

BBS, from 137 (Rev. 8-99)



SOIL BORING LOG

Page 1 of 1

Date 7/29/22

ROUTE Warrenville Rd. DESCRIPTION Warrenville Rd. Retaining Walls LOGGED BY Sponaugle

SECTION LOCATION 1872917.925,1052606.076

COUNTY DuPage DRILLING METHOD Hollow Stem Auger HAMMER TYPE B57 Auto (91% efficiency)

STRUCT. NO. Station	DEPTH H	BLOW S	UCS Qu	MOIST T	Surface Water Elev. _____ ft				DEPTH H	BLOW S	UCS Qu	MOIST T
					Stream Bed Elev. _____ ft							
BORING NO. SB-05 Station 215+97 Offset 29.10ft LT Ground Surface Elev. 670.95 ft					Groundwater Elev.: First Encounter 655.0 ft Upon Completion 657.4 ft After _____ Hrs. Not taken ft							
ASPHALT (8")	0	670.25			Stiff, gray, moist SILTY CLAY (continued)				0	650.45		
Stiff, black, moist SILTY CLAY, trace fine gravel, trace coarse to fine sand, low plasticity	5				Medium dense, gray, wet well graded SAND, trace gravel				3		7.0	
	3		12.0						5			
	2	1.5							7			
Collected Shelby tube 3.5-5.5'					Medium dense, some fine gravel				7		10.1	
Stiff, trace organics	2		34.4									
	2	1.7										
Medium stiff, black with green mottling, no sand or gravel, medium plasticity	2		50.5									
	1	1.0										
Loose, brown, moist coarse to fine SANDY LOAM, trace fine gravel	2		19.1									
	3											
	5											
Medium dense, gray, moist SILT	4		17.0									
	4											
Loose, gray, moist well graded SAND, trace fine gravel, trace silt	4		17.0									
	10											
Free water at 16'	2		23.4									
Loose, wet	3											
	4											
Stiff, gray, moist SILTY CLAY	2		23.0									
	2	1.8										

The Unconfined Compressive Strength (UCS) Failure Mode is indicated by (B-Bulge, S-Shear, P-Penetrometer)

BBS, from 137 (Rev. 8-99)



SOIL BORING LOG

Page 1 of 1

Date 7/29/22

ROUTE Warrenville Rd. DESCRIPTION Warrenville Rd. Retaining Walls LOGGED BY Sponaugle

SECTION LOCATION 1872919.681,1052668.969

COUNTY DuPage DRILLING METHOD Hollow Stem Auger HAMMER TYPE B57 Auto (91% efficiency)

STRUCT. NO. Station	DEPTH H	BLOW S	UCS Qu	MOIST T	Surface Water Elev. _____ ft				DEPTH H	BLOW S	UCS Qu	MOIST T
					Stream Bed Elev. _____ ft							
BORING NO. SB-08 Station 216+61 Offset 28.00ft LT Ground Surface Elev. 669.69 ft					Groundwater Elev.: First Encounter 658.7 ft Upon Completion 657.7 ft After _____ Hrs. Not taken ft							
ASPHALT (8")	0	668.99			Medium stiff, brown with black mottling, moist SILTY CLAY, little coarse to fine sand, trace gravel, low plasticity				2		13.2	
	2								2			
	2	0.5										
Soft, black, moist CLAY LOAM, some coarse to fine sand Disturbed sample	3				Medium dense, wet, SANDY LOAM, trace gravel				3		15.4	
	1								1			
	3								3			
Shelby tube collected 6-8'												
Soft, brown, moist coarse to fine SANDY CLAY LOAM, trace fine gravel Disturbed sample	1		15.8									
	2											
	2											
Medium dense, wet, SANDY LOAM, trace gravel	5		11.3									
	6											
Free water at 11'	5											
Loose, gray, wet	3		10.8									
	4											
	4											
Stiff, gray, moist SILTY CLAY, trace coarse to fine sand, low plasticity	2		23.4									
	2											
	5	1.5										
Soft, moist Disturbed sample	2		22.6									
	5											
	7											

The Unconfined Compressive Strength (UCS) Failure Mode is indicated by (B-Bulge, S-Shear, P-Penetrometer)

BBS, from 137 (Rev. 8-99)

PLOT DATE = 2/9/2024



DESIGNED - NR	REVISED
CHECKED - MS	REVISED
DRAWN - MN	REVISED
CHECKED - MS	REVISED

STATE OF ILLINOIS DEPARTMENT OF TRANSPORTATION

BORING LOGS - 2 EAST & WEST RETAINING WALLS

SHEET SA-12 OF 13 SHEETS

F.A.U. RTE.	SECTION	COUNTY	TOTAL SHEETS	SHEET NO.
1479	14-00124-00-BR	DUPAGE	208	166
CONTRACT NO. 61J14				
ILLINOIS FED. AID PROJECT				



SOIL BORING LOG

Page 1 of 1

Date 7/29/22

ROUTE Warrenville Rd. DESCRIPTION Warrenville Rd. Retaining Walls LOGGED BY Sponaugle

SECTION LOCATION 1872921.360,1052731.585

COUNTY DuPage DRILLING METHOD Hollow Stem Auger HAMMER TYPE B57 Auto (91% efficiency)

STRUCT. NO.	Station	D E P T H	B L O W S	U C S Qu	M O I S T	Surface Water Elev. _____ ft	Stream Bed Elev. _____ ft
BORING NO.	Station	(ft)	(/6")	(tsf)	(%)	Groundwater Elev.:	
	Offset					First Encounter	
	Ground Surface Elev.					Upon Completion	
						After _____ Hrs.	Not taken ft
ASPHALT (7")	658.17						
Very stiff, brown with black and green mottling, moist SILTY CLAY, trace fine gravel, trace fine sand, low plasticity		2	4	2.0	17.2		
		4		B			
Very stiff, black, trace organics		2	2	2.1	25.1		
		3		S			
Shelby tube collected 6-8'				PUSH	32.7		
Soft, blackish brown, trace organics		1	2		30.2		
		10	1	0.3			
	658.27			P			
Medium dense, gray, wet coarse to fine SANDY LOAM, little fine gravel		5					
Free water at 11'		6			11.2		
		4					
Medium dense, gray, moist SILT, trace clay	655.77						
		3					
		5			16.9		
		15					
Loose, gray, wet coarse to fine SILTY LOAM, some fine gravel	653.27						
		5					
		3			8.6		
		8					
Medium dense		5			13.4		
End of boring at 20'	648.77	20	6				

The Unconfined Compressive Strength (UCS) Failure Mode is indicated by (B-Bulge, S-Shear, P-Penetrometer)

BBS, from 137 (Rev. 8-99)

PLOT DATE = 2/9/2024



DESIGNED - NR	REVISED
CHECKED - MS	REVISED
SCALE - NONE	REVISED
DATE - 2/9/2024	REVISED
DRAWN - MN	REVISED
CHECKED - MS	REVISED

STATE OF ILLINOIS
DEPARTMENT OF TRANSPORTATION

BORING LOGS - 3
EAST & WEST RETAINING WALLS

SHEET SA-13 OF 13 SHEETS

F.A.U. RTE.	SECTION	COUNTY	TOTAL SHEETS	SHEET NO.
1479	14-00124-00-BR	DUPAGE	208	167
CONTRACT NO. 61J14				
ILLINOIS FED. AID PROJECT				

PAVEMENT MARKING LOCATION

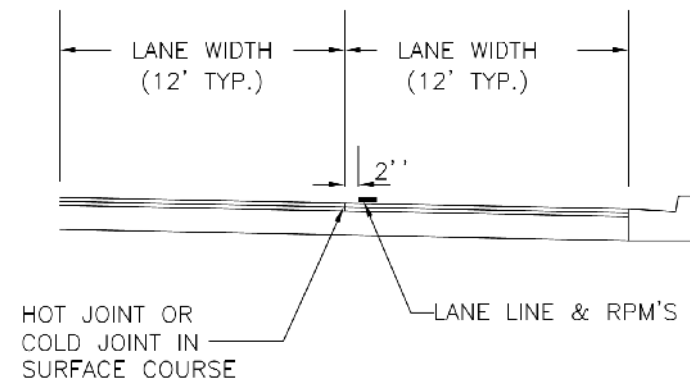

12-14-2017
DuPage County D.O.T.

DETAILS FOR STEEL PLATE BEAM GUARDRAIL ADJACENT TO CURB AND GUTTER

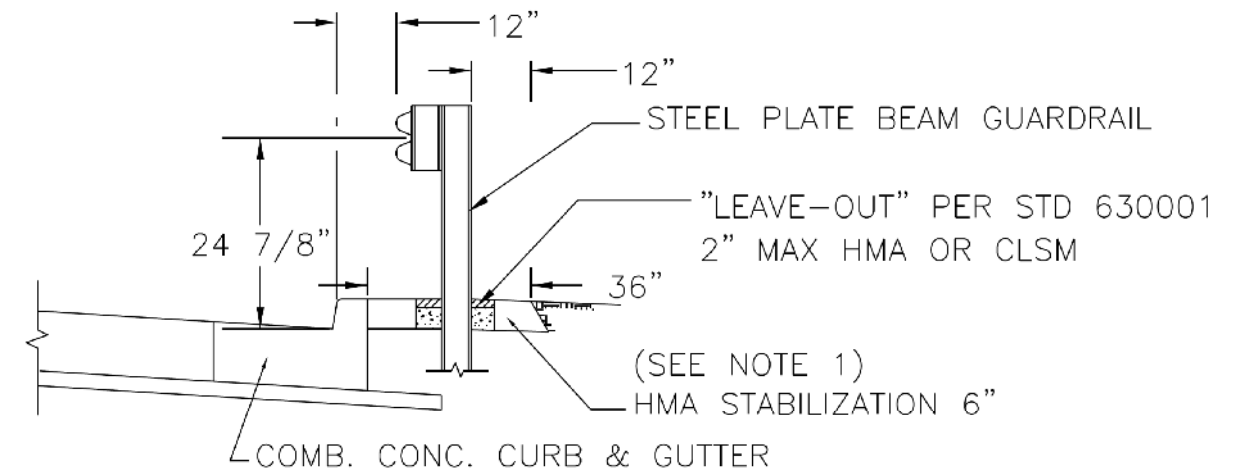

- NOTES:
1. THE HMA STABILIZATION SHALL EXTEND UNDER THE TRAFFIC BARRIER TERMINAL.
 2. GUARDRAIL MAY BE PLACED AT THE BACK OF CURB WHEN DIRECTED BY THE ENGINEER.
 3. GUARDRAIL POSTS TO CORED PER ARTICLE 630.06.
 4. WHEN THE DISTANCE BETWEEN THE FACE OF CURB AND THE FACE OF GUARDRAIL IS GREATER THAN 12", THE CURB SHALL BE "MOUNTABLE".

1/29/2018
DuPAGE COUNTY D.O.T.

TRAFFIC BARRIER TERMINAL TYPE 1 SPECIAL ADJACENT TO CURB AND GUTTER

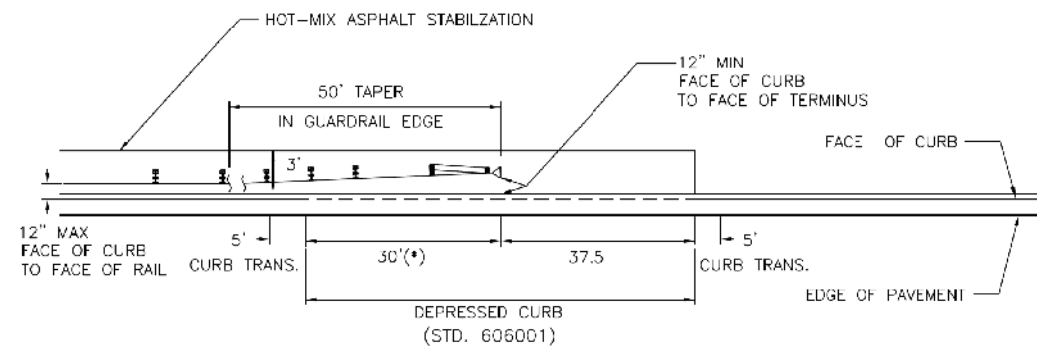

(*) NOTE: DEPRESSED CURB WHERE FACE OF GUARDRAIL OR TRAFFIC BARRIER TERMINAL IS MORE THAN 12" FROM FACE OF CURB.

1/31/2018
DuPAGE COUNTY D.O.T.

MODEL: 440BELNAMES
FILE NAME: 719402-114-DOTStandards_01.dgn

KNIGHT
Member of WSP

DESIGNED -	D.M.S.	REVISED -	
DRAWN -	D.M.S.	REVISED -	
CHECKED -	J.R.S.	REVISED -	
DATE -	2/8/2024	REVISED -	

**STATE OF ILLINOIS
DEPARTMENT OF TRANSPORTATION**

**DUPAGE COUNTY DOT STANDARD DETAILS
WARRENVILLE ROAD**

SCALE: NONE SHEET 1 OF 5 SHEETS STA. TO STA.

F.A.U. RTE.	SECTION	COUNTY	TOTAL SHEETS	SHEET NO.
1479	14-00124-04-BR	DUPAGE	208	168
CONTRACT NO. 61114				
ILLINOIS FED. AID PROJECT				

MEDIAN DETAILS

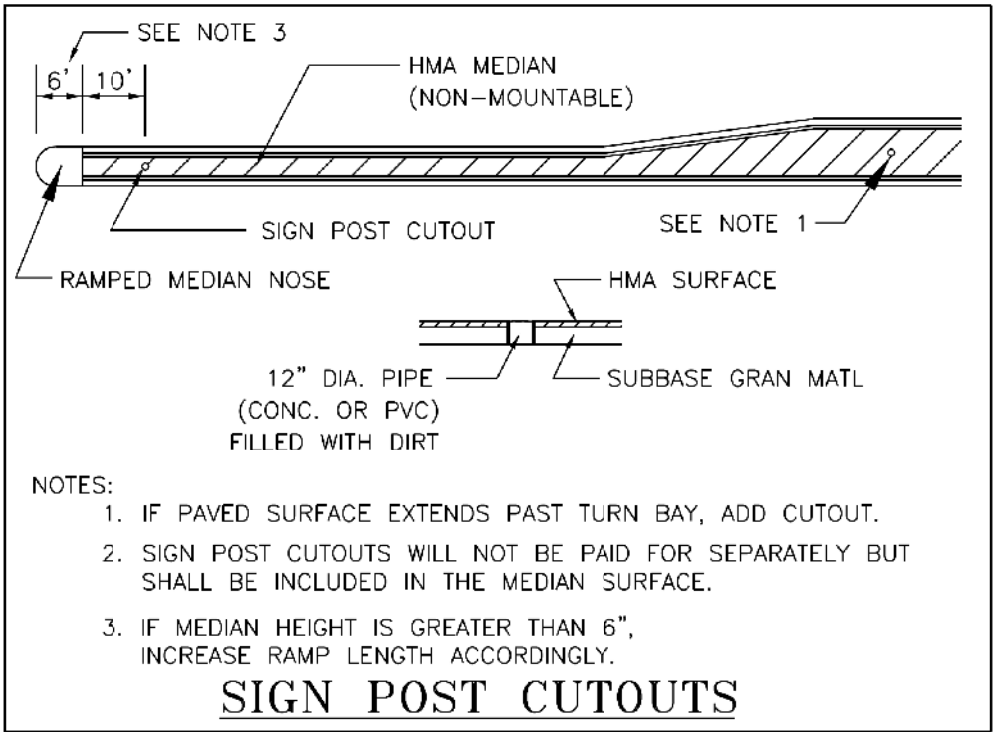
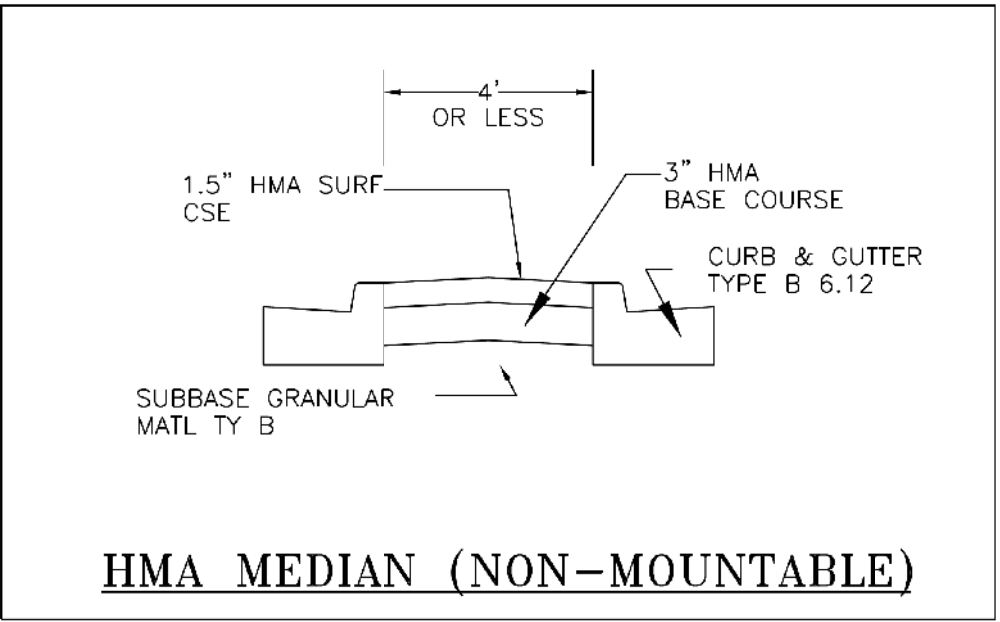
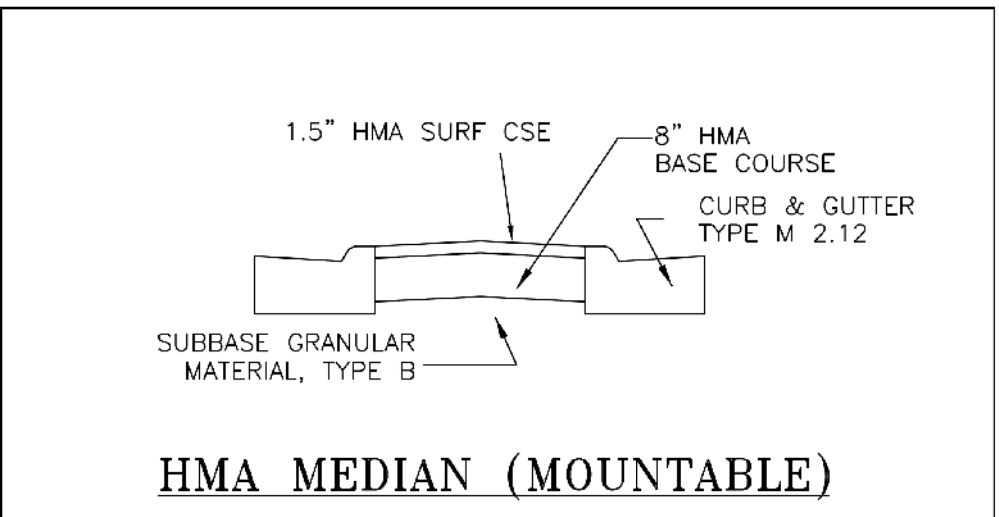
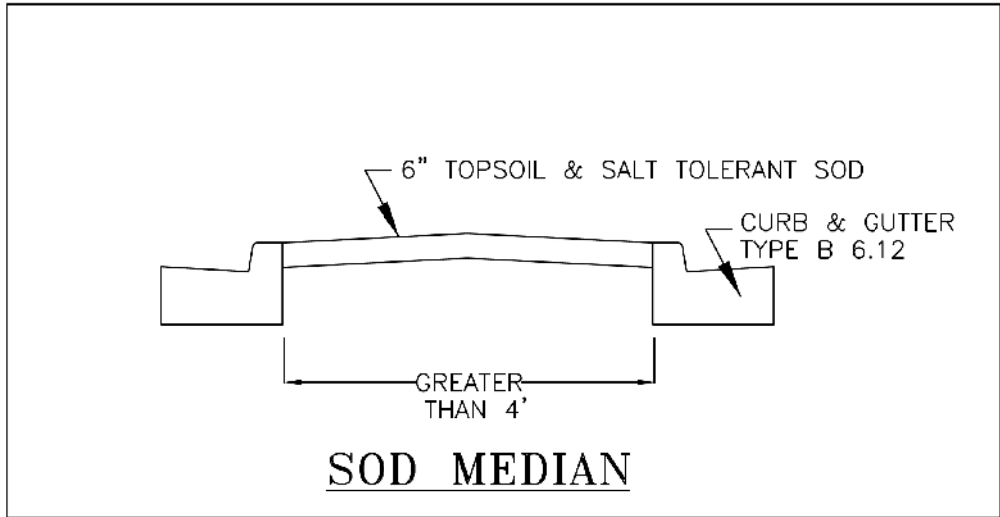

- NOTES:
1. IF PAVED SURFACE EXTENDS PAST TURN BAY, ADD CUTOUT.
 2. SIGN POST CUTOUTS WILL NOT BE PAID FOR SEPARATELY BUT SHALL BE INCLUDED IN THE MEDIAN SURFACE.
 3. IF MEDIAN HEIGHT IS GREATER THAN 6", INCREASE RAMP LENGTH ACCORDINGLY.

1/30/2018
DuPAGE COUNTY D.O.T.

MODEL: 4400BELNAMES
FILE: NAME: 7194005-14-CURB-GUTTER-Standard_01.dgn



DESIGNED -	D.M.S.	REVISED -	
DRAWN -	D.M.S.	REVISED -	
CHECKED -	J.R.S.	REVISED -	
DATE -	2/8/2024	REVISED -	

**STATE OF ILLINOIS
DEPARTMENT OF TRANSPORTATION**

**DUPAGE COUNTY DOT STANDARD DETAILS
WARRENVILLE ROAD**

SCALE: NONE SHEET 2 OF 5 SHEETS STA. TO STA.

F.A.U. RTE.	SECTION	COUNTY	TOTAL SHEETS	SHEET NO.
1479	14-00124-04-BR	DUPAGE	208	169
CONTRACT NO. 61114				
		ILLINOIS FED. AID PROJECT		

PAVEMENT MARKINGS AND PAVEMENT MARKERS

MATERIALS FOR PAVEMENT MARKINGS:

<u>LOCATION</u>	<u>MATERIAL</u>
ALL MARKINGS ON BITUMINOUS PAVEMENT	THERMOPLASTIC PAVEMENT MARKINGS
ALL MARKINGS ON CONCRETE SURFACES	URETHANE PAVEMENT MARKINGS

INSTALLATION OF PAVEMENT MARKINGS:

<u>LOCATION</u>		<u>TYPE OF MARKING</u>
PAINTED MEDIANS		4" DOUBLE YELLOW; 11" c-c AND 12" YELLOW @ 45°; 30' c-c
BARRIER MEDIANS		4" YELLOW
TURN BAY TAPERS ALONG THRU LANES	6" WHITE, 2' LONG, 6' SPACE (DOTTED WHITE)	
START OF TURN BAYS		ARROW AND "ONLY"
END OF TURN BAYS 150'-200' LONG		ADDITIONAL ARROW 10' FROM END
TURN BAYS > 200' LONG		ADDITIONAL "ONLY"
ALL OTHER MARKINGS PER MANUAL OF UNIFORM TRAFFIC CONTROL DEVICES OF ILLINOIS.		

INSTALLATION OF RECESSED REFLECTIVE PAVEMENT MARKERS:

<u>LOCATION</u>		<u>SPACING</u>
DOUBLE YELLOW CENTERLINE, & SKIP-DASH WHITE LANE LINES APPROACH & DEPARTURE FROM INTERSECTIONS & CURVES* * EQUAL TO LENGTH OF TURN BAY, OR 200'		40'
ALONG CURVES OR TAPERS		40'
TANGENT SECTIONS		40'
SOLID LANE LINES (TURN BAYS)		40'
END OF PAINTED MEDIANS		3 @ 3' LATERAL
<u>LOCATION</u>	<u>TYPE</u>	
DOUBLE YELLOW CENTERLINE	2-WAY YELLOW	
PAINTED MEDIANS ≤ 4' WIDE	2-WAY YELLOW	
PAINTED MEDIANS > 4' WIDE	1-WAY YELLOW	
YELLOW LINE ALONG BARRIER MEDIANS ** EXCEPT IN SPECIAL CIRCUMSTANCES	NONE **	
SKIP-DASH WHITE LANE LINES, SOLID LANE LINES (TURN BAYS)	1-WAY WHITE	
2-WAY, UNDIVIDED ROADWAY	2-WAY WHITE / RED	
1-WAY ROADWAY, OR DIVIDED WITH BARRIER MEDIAN		

9/1/2020
DuPAGE COUNTY D.O.T.

RECESSED PAVEMENT MARKER

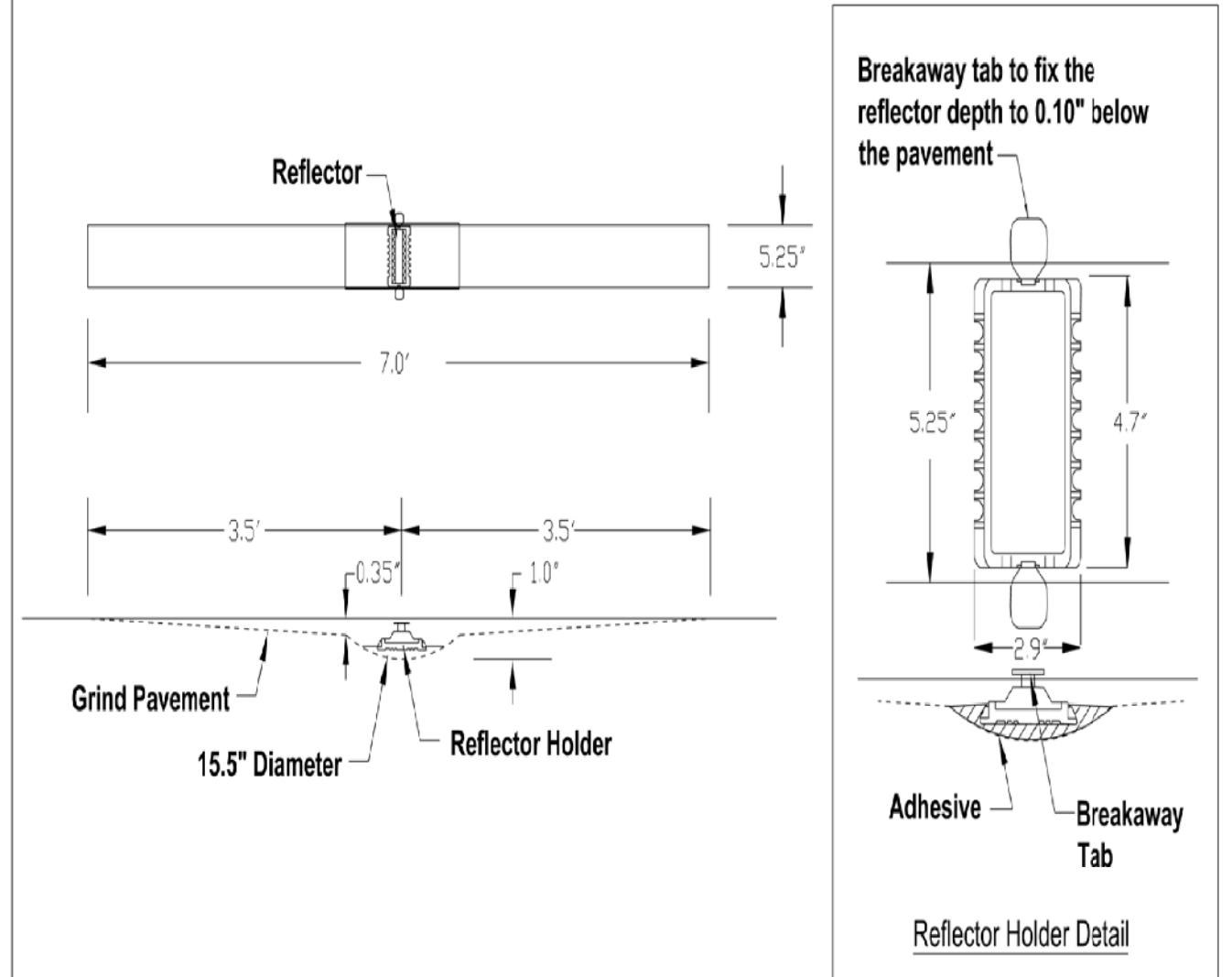

9/1/2020
DuPAGE COUNTY D.O.T.

MODEL: 4400BELMARKS
FILE NAME: 719402-14-04-DOTStandards_01.dgn

KNIGHT
Member of WSP

DESIGNED -	D.M.S.	REVISED -	
DRAWN -	D.M.S.	REVISED -	
CHECKED -	J.R.S.	REVISED -	
DATE -	2/8/2024	REVISED -	

**STATE OF ILLINOIS
DEPARTMENT OF TRANSPORTATION**

**DUPAGE COUNTY DOT STANDARD DETAILS
WARRENVILLE ROAD**

SCALE: NONE SHEET 3 OF 5 SHEETS STA. TO STA.

F.A.U. RTE.	SECTION	COUNTY	TOTAL SHEETS	SHEET NO.
1479	14-00124-04-BR	DUPAGE	208	170
CONTRACT NO. 61114				
ILLINOIS FED. AID PROJECT				

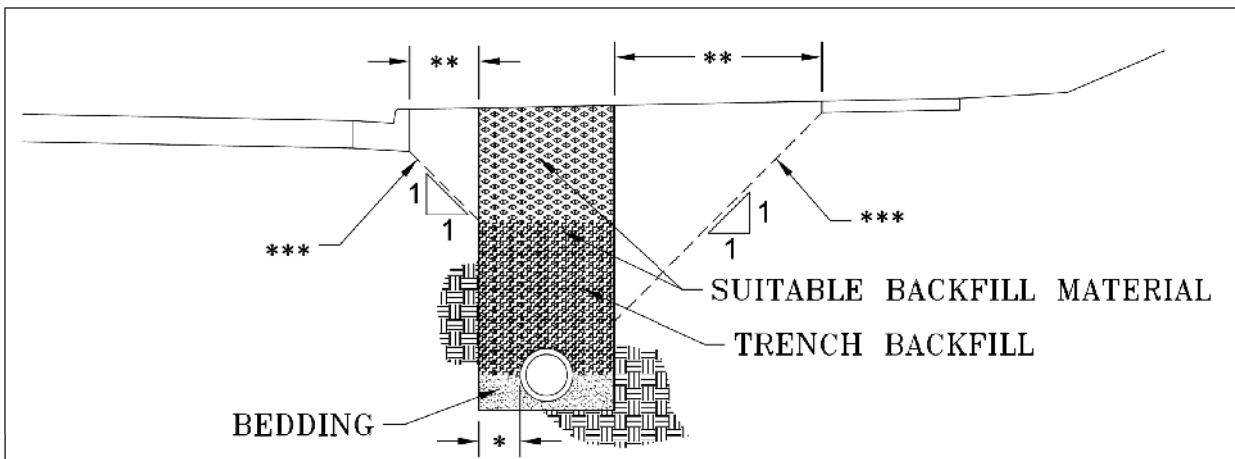

* TRENCH WIDTH PER ARTICLE 550.04 OF THE STANDARD SPECIFICATIONS. WHERE THE TRENCH WIDTH IS WIDER, THE ADDITIONAL TRENCH BACKFILL SHALL BE AT THE CONTRACTOR'S EXPENSE.

*** LINE OF INFLUENCE: USE TRENCH BACKFILL MATERIAL FOR THE FULL WIDTH OF THE TRENCH WHEN THE INNER EDGE OF THE TRENCH IS BELOW A LINE EXTENDING 1H:1V FROM THE EDGE OF PAVEMENT, CURB, GUTTER, CURB AND GUTTER, STABILIZED SHOULDER, OR SIDEWALK.

DuPAGE COUNTY TRENCH BACKFILL DETAIL

1/31/2018
DuPAGE COUNTY D.O.T.

**DUPAGE COUNTY DIVISION OF TRANSPORTATION
TRENCH BACKFILL STANDARD IN PAVED AREAS**

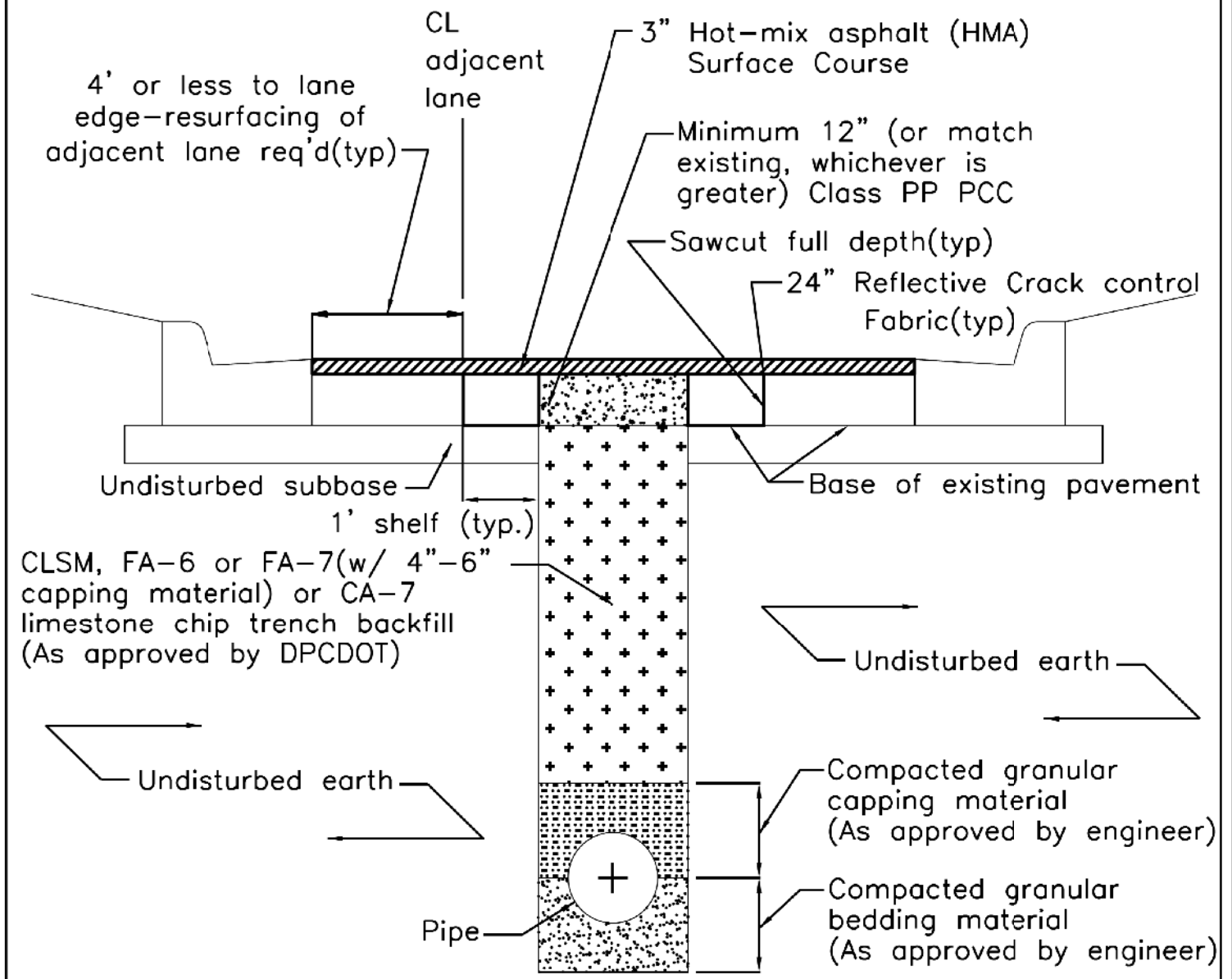

CLSM, FA-6 or FA-7(w/ 4"-6" capping material) or CA-7 limestone chip trench backfill (As approved by DPCDOT)

Notes:

1. All materials per IDOT's "Standard Specifications for Road & Bridge Construction" (latest edition) and "Supplemental Recurring Special Provisions" (latest edition).
2. Replace all pavement markings, striping, symbols and pavement markers in kind.

TYPICAL TURN BAYS

NOTES:
1. SEE MEDIAN DETAILS FOR MEDIAN DEPTH DESIGN, CURB TYPE, AND SIGN POST CUTOUTS.
*ADJUST FOR CURVE SECTION (12:1/0:1)

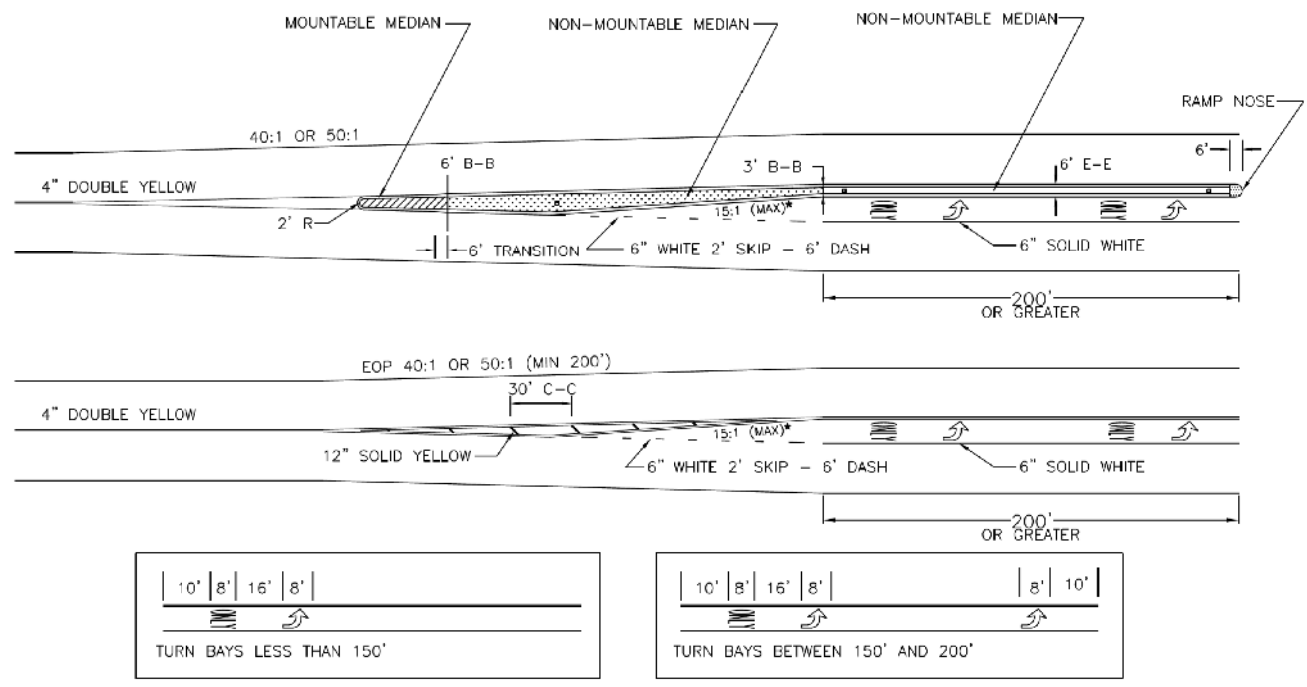

MODEL: 4400BELNAMES
FILE NAME: 719402-14-DOTStandards_01.dgn



DESIGNED -	D.M.S.	REVISED -	
DRAWN -	D.M.S.	REVISED -	
CHECKED -	J.R.S.	REVISED -	
DATE -	2/8/2024	REVISED -	

STATE OF ILLINOIS
DEPARTMENT OF TRANSPORTATION

DUPAGE COUNTY DOT STANDARD DETAILS
WARRENVILLE ROAD

SCALE: NONE SHEET 4 OF 5 SHEETS STA. TO STA.

F.A.U. RTE.	SECTION	COUNTY	TOTAL SHEETS	SHEET NO.
1479	14-00124-04-BR	DUPAGE	208	171
CONTRACT NO. 61114				
ILLINOIS FED. AID PROJECT				

TYPICAL CURBED SIDE ROAD APPROACH

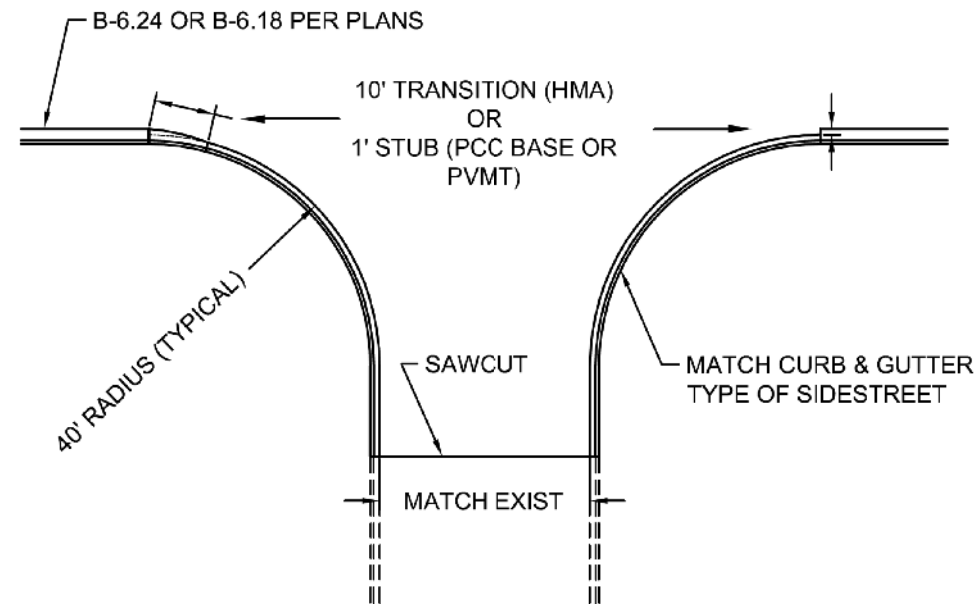

SIDEROAD PAVEMENT SECTION:
 1.75" HMA SURFACE COURSE, MIX D, N50
 2.25" HMA BINDER COURSE, IL-19.0, N50
 6" HMA BASE COURSE
 8" SUB-BASE GRANULAR MATERIAL

DUPAGE COUNTY DIVISION OF TRANSPORTATION PRIVATE ENTRANCE DETAIL

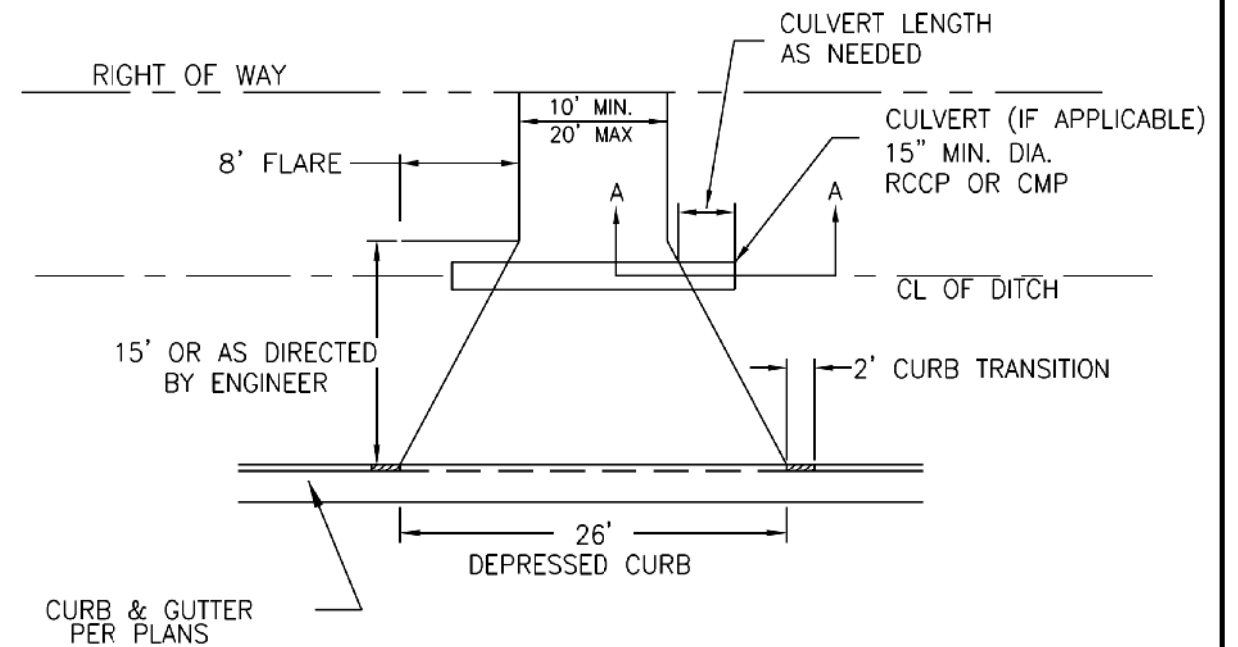

HMA DRIVEWAY
 1½" HMA SURFACE COURSE
 1½" HMA BINDER COURSE
 8" AGGREGATE BASE COURSE, TYPE B

PCC DRIVEWAY
 7" PCC DRIVEWAY PAVEMENT
 8" AGGREGATE BASE COURSE, TYPE B

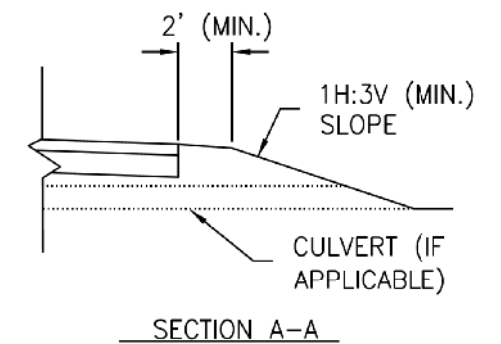

1/29/2018 DuPAGE COUNTY D.O.T.

MODEL: 4400BELNAMES
 FILE: M:\m\7194002-114-DuDOTStandards_01.dgn



DESIGNED -	D.M.S.	REVISED -	
DRAWN -	D.M.S.	REVISED -	
CHECKED -	J.R.S.	REVISED -	
DATE -	2/8/2024	REVISED -	

STATE OF ILLINOIS
 DEPARTMENT OF TRANSPORTATION

DUPAGE COUNTY DOT STANDARD DETAILS
 WARRENVILLE ROAD

SCALE: NONE SHEET 5 OF 5 SHEETS STA. TO STA.

F.A.U. RTE.	SECTION	COUNTY	TOTAL SHEETS	SHEET NO.
1479	14-00124-04-BR	DUPAGE	208	172
CONTRACT NO. 61114				
ILLINOIS FED. AID PROJECT				

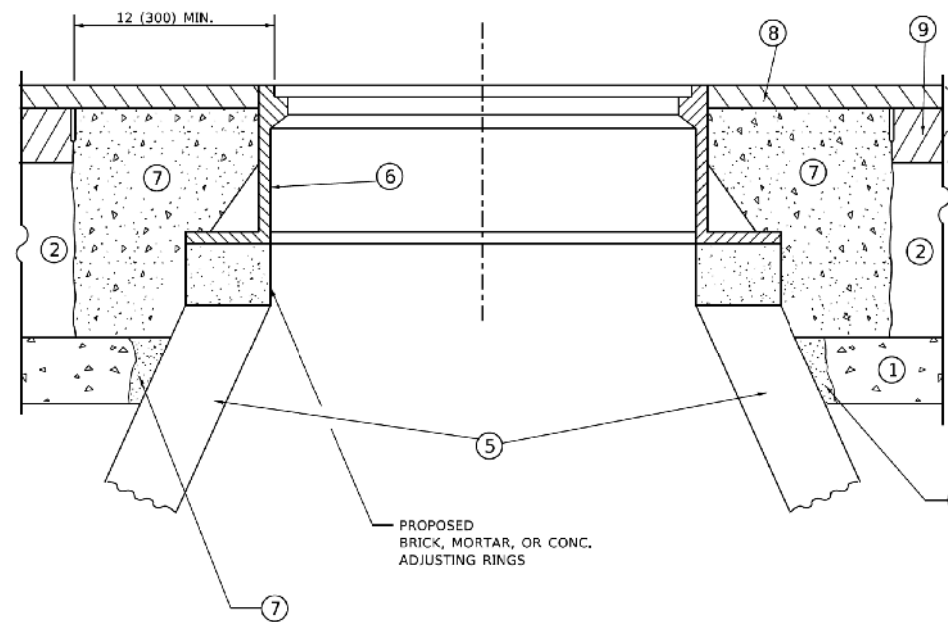
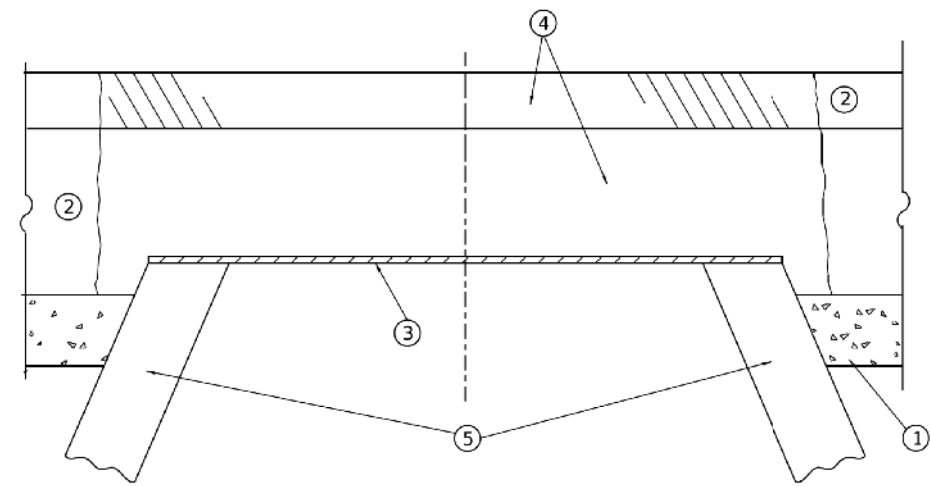

**DETAILS FOR FRAMES AND LIDS ADJUSTMENT
WITH MILLING**

NOTES

- EXISTING BROKEN FRAMES AND LIDS SHALL BE REMOVED AND DISPOSED OF BY THE CONTRACTOR AND SHALL BE REPLACED AS DIRECTED BY THE ENGINEER. REPLACEMENT FRAMES AND LIDS WILL BE PAID FOR IN ACCORDANCE WITH ARTICLE 109.04 OF THE STANDARD SPECIFICATIONS UNLESS A SEPARATE PAY ITEM HAS BEEN PROVIDED.
- IF THE EXISTING LIDS ARE OPEN, THE FRAME WILL BE ADJUSTED TO THE ELEVATION OF THE MILLED PAVEMENT SURFACE PRIOR TO THE MILLING OPERATION. THE FRAME WILL NOT BE REMOVED AND COVERED BY THE METAL PLATE.
- CITY OF CHICAGO CASTINGS ARE THE PROPERTY OF THE CITY AND THE CONTRACTOR SHALL NOTIFY THE CITY FOR REMOVAL AND DISPOSITION OF THE CASTINGS.
- THE METAL PLATE USED TO COVER THE STRUCTURE SHALL REMAIN THE PROPERTY OF THE CONTRACTOR.
- THE CONTRACTOR SHALL REMOVE ALL TRAFFIC CONTROL DEVICES BY THE END OF EACH WORK SHIFT.

CONSTRUCTION PROCEDURES

STAGE 1 (BEFORE PAVEMENT MILLING)

- REMOVE A MINIMUM OF 12 (300) OF THE PAVEMENT FROM AROUND THE STRUCTURE.
- REMOVE THE EXISTING FRAME AND LID FROM THE STRUCTURE.
- COVER THE STRUCTURE OPENING WITH A 36 (900) DIAMETER METAL PLATE.
- BACKFILL WITH CRUSHED STONE AND HMA SURFACE MIX APPROVED BY THE ENGINEER. (MIN. 3 (80) HMA TO REMAIN AFTER MILLING).

STAGE 2 (AFTER PAVEMENT MILLING)

- REMOVE THE HMA SURFACE MIX AND CRUSHED STONE.
- INSTALL THE FRAME AND LID; ADJUST THE FRAME TO ITS FINAL SURFACE ELEVATION.
- THE SURROUNDING SPACE SHALL BE FILLED WITH CLASS PP-2* CONCRETE TO THE ELEVATION OF THE SURFACE OF THE EXISTING BASE COURSE OR THE BINDER COURSE.

* UNLESS OTHERWISE SPECIFIED IN THE PLANS.

THE PROCEDURE EXPLAINED ABOVE SHALL CONFORM TO THE APPLICABLE PORTIONS OF SECTIONS 353, 406, 602, AND 603 OF THE STANDARD SPECIFICATIONS EXCEPT THAT "THE CONTRACTOR SHALL ADJUST THE STRUCTURES TO THE FINISHED PAVEMENT ELEVATION NO MORE THAN 5 CALENDAR DAYS PRIOR TO PLACEMENT OF THE FINAL LIFT OF SURFACE UNLESS APPROVED BY THE ENGINEER."

LEGEND

- | | |
|--|-------------------------------|
| ① SUB-BASE GRANULAR MATERIAL | ⑥ FRAME AND LID (SEE NOTES) |
| ② EXISTING PAVEMENT | ⑦ CLASS PP-2* CONCRETE |
| ③ 36 (900) DIAMETER METAL PLATE | ⑧ PROPOSED HMA SURFACE COURSE |
| ④ PROPOSED CRUSHED STONE AND HMA SURFACE MIX | ⑨ PROPOSED HMA BINDER COURSE |
| ⑤ EXISTING STRUCTURE | |

LOCATION OF STRUCTURES

THE CONTRACTOR WILL BE REQUIRED TO KEEP A RECORD OF THE LOCATIONS OF THE BURIED STRUCTURES ACCORDING TO THE STATION AND DISTANCE LEFT OR RIGHT OF THE CENTERLINE OF PAVEMENT. UPON COMPLETION OF THE WORK, THE CONTRACTOR WILL DELIVER THE RECORD TO THE ENGINEER.

BASIS OF PAYMENT

- REMOVING FRAMES AND LIDS ON DRAINAGE AND UTILITY STRUCTURES IN THE PAVEMENT PRIOR TO MILLING, AND ADJUSTING TO FINAL GRADE PRIOR TO PLACING THE SURFACE COURSE, WILL BE PAID FOR AT THE CONTRACT UNIT PRICE EACH FOR "FRAMES AND LIDS TO BE ADJUSTED (SPECIAL)."
- THIS WORK WILL NOT BE PAID FOR WHEN DRAINAGE AND UTILITY STRUCTURES ARE SPECIFIED FOR PAYMENT AS STRUCTURE RECONSTRUCTION.
- NEW FRAMES AND LIDS, WHEN SPECIFIED, WILL BE PAID FOR SEPARATELY.
- WHEN STRUCTURES ARE TO BE ADJUSTED OR RECONSTRUCTED, THE LOWERING AND RAISING OF THE FRAMES AND LIDS WILL NOT BE PAID FOR SEPARATELY BUT WILL BE INCLUDED IN THE COST OF THE CORRESPONDING PAY ITEM.

ALL DIMENSIONS ARE IN INCHES (MILLIMETERS) UNLESS OTHERWISE SHOWN

MODEL: 146468
FILE: 146468_1464680274346468.dgn



USER NAME = Lawrence.DeManche	DESIGNED - R. SHAH	REVISED - R. BORO 03-09-11
	DRAWN -	REVISED - R. BORO 12-06-11
PLOT SCALE = 100.0000' / 1" =	CHECKED -	REVISED - K. SMITH 11-18-22
PLOT DATE = 9/15/2023	DATE - 10-25-94	REVISED - K. SMITH 09-15-23

**STATE OF ILLINOIS
DEPARTMENT OF TRANSPORTATION**

**DETAILS FOR
FRAMES AND LIDS ADJUSTMENT WITH MILLING**

SCALE: NONE SHEET 1 OF 1 SHEETS STA. TO STA.

F.A. RTE.	SECTION	COUNTY	TOTAL SHEETS	SHEET NO.
1479	14-00124-04-BR	DUPAGE	208	173
BD600-03 (BD-08)			CONTRACT NO. 61114	
(ILLINOIS) FED. AID PROJECT				

METHOD OF MEASUREMENT

REFER TO SECTION 442 OF THE STANDARD SPECIFICATIONS FOR ROAD AND BRIDGE CONSTRUCTION AND THE RECURRING SPECIAL PROVISION "PATCHING WITH HOT-MIX ASPHALT OVERLAY REMOVAL."

BASIS OF PAYMENT

1. REFER TO SECTION 442 OF THE STANDARD SPECIFICATIONS FOR ROAD AND BRIDGE CONSTRUCTION AND THE RECURRING SPECIAL PROVISION "PATCHING WITH HOT-MIX ASPHALT OVERLAY REMOVAL."
2. SAW CUT/SCORING OF EXISTING HMA OVERLAY IS INCLUDED IN THE COST OF PAVEMENT PATCHING.
3. SAW CUT/SCORING OF EXISTING PAVEMENT IS INCLUDED IN THE COST OF PAVEMENT PATCHING.

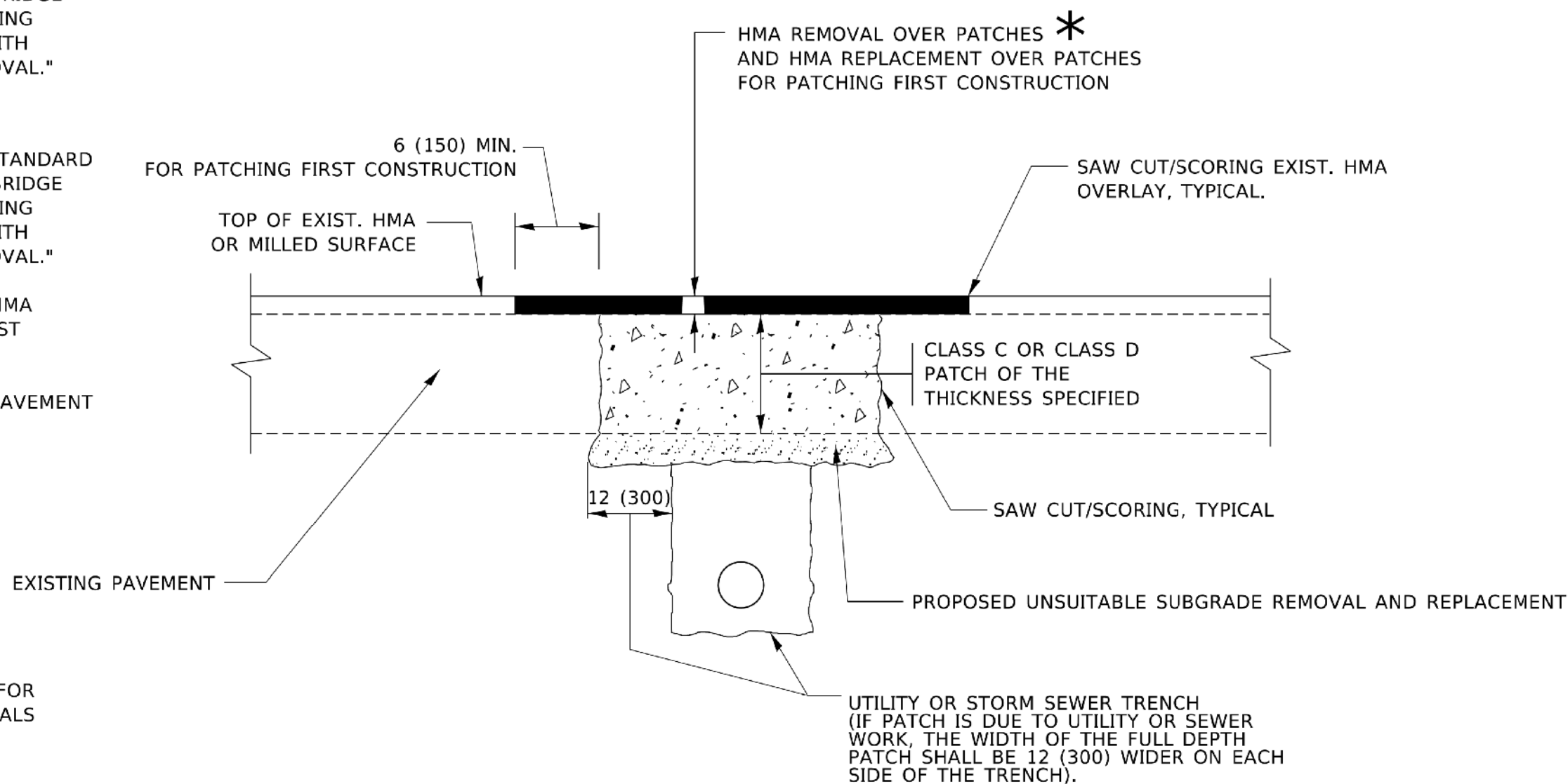

* SEE TYPICAL SECTIONS FOR THICKNESS AND MATERIALS

SEQUENCE OF CONSTRUCTION (PATCHING FIRST)

1. REMOVE THE EXISTING HMA MATERIAL OVER THE AREA TO BE PATCHED.
2. REMOVE AND REPLACE WITH CLASS C OR D PATCH.
3. REPLACE HMA MATERIAL OVER THE AREA TO BE PATCHED.

SEQUENCE OF CONSTRUCTION (MILLING FIRST)

1. MILL HMA FIRST IF THERE IS AT LEAST 4½ INCHES OR MORE OF HMA MATERIAL ON TOP OF THE EXISTING PAVEMENT OR IF THE PAVEMENT IS FULL DEPTH HMA. A MINIMUM OF 2 INCHES OF HMA MATERIAL SHALL BE IN PLACE AFTER MILLING.
2. REMOVE AND REPLACE WITH FULL DEPTH CLASS D PATCHES TO TOP OF MILLED SURFACE.

ALL DIMENSIONS ARE IN INCHES (MILLIMETERS) UNLESS OTHERWISE SHOWN.

MODEL: Default
FILE: \bentley\production\dwg\entire\DOT\chicago\140024\140024-04-BR\140024-04-BR-22.dgn

 Member of WSP	USER NAME = Lawrence.DeManche DESIGNED - R. SHAH DRAWN - CHECKED - DATE - 10-25-94	REVISED - R. BORO 01-01-07 REVISED - R. BORO 09-04-07 REVISED - K. ENG 10-27-08 REVISED - K. SMITH 11-18-22	STATE OF ILLINOIS DEPARTMENT OF TRANSPORTATION	PAVEMENT PATCHING FOR HMA SURFACED PAVEMENT			F.A. RTE.	SECTION	COUNTY	TOTAL SHEETS	SHEET NO.	
	PLOT SCALE = 100,0000 1/1 in.	PLOT DATE = 11/18/2022					SCALE: NONE	SHEET 1	OF 1	SHEETS	STA.	TO STA.
						BD400-04 (BD-22)			CONTRACT NO. 61114			
						ILLINOIS			FED. AID PROJECT			

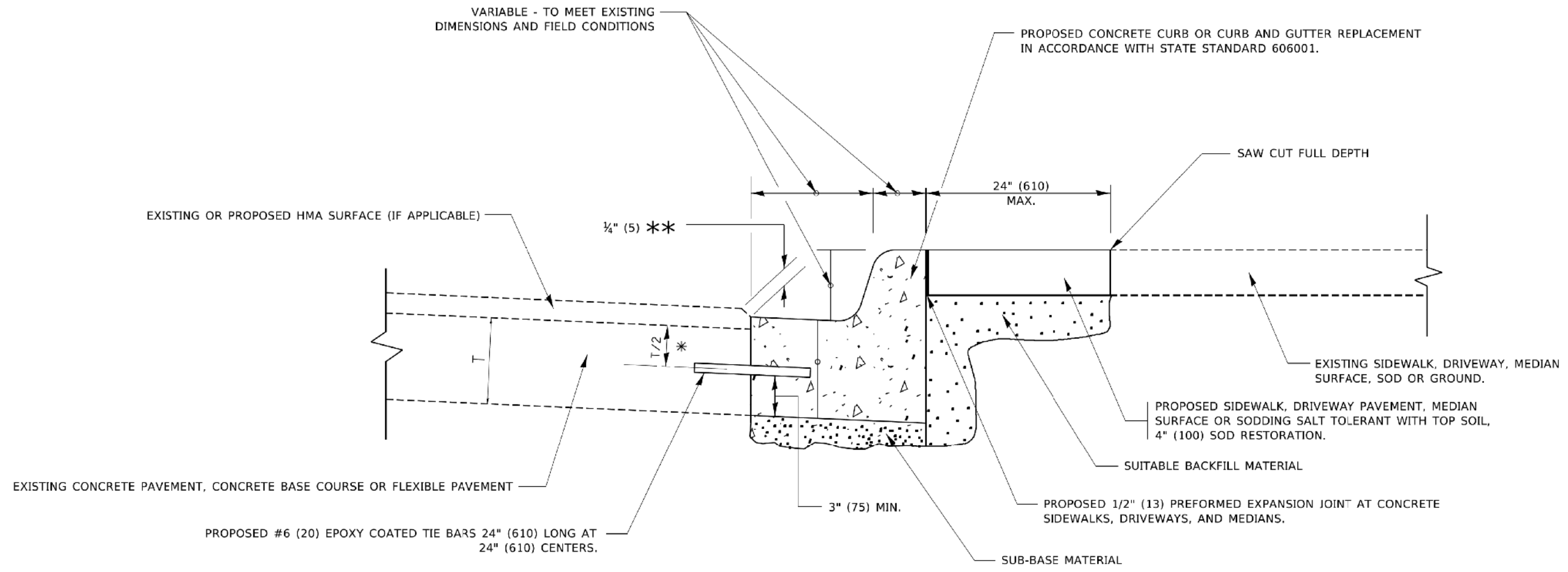

- * 3" (75) MINIMUM FROM TOP AND BOTTOM OF THE CONCRETE PAVEMENT OR BASE COURSE.
- ** IF THE FINAL SURFACE OF THE PAVEMENT IS CONCRETE, THE GUTTER IS TO BE FLUSH WITH THE PAVEMENT.

CURB OR CURB AND GUTTER REMOVAL AND REPLACEMENT

ALL DIMENSIONS ARE IN INCHES (MILLIMETERS) UNLESS OTHERWISE SHOWN.

MODEL: D:\pilot\pilot.dwg
 FILE: D:\pilot\pilot.dwg
 PLOT: D:\pilot\pilot.dwg
 PLOT DATE: 7/11/2019
 PLOT SCALE: 1/16" = 1'-0"
 PLOT SIZE: 11" x 17"



USER NAME = foote[m]	DESIGNED - A. HOUSEH	REVISED - A. ABBAS 03-21-97
	DRAWN -	REVISED - M. GOMEZ 01-22-01
PLOT SCALE = 50.0000 ' / in.	CHECKED -	REVISED - R. BORO 12-15-09
PLOT DATE = 7/11/2019	DATE - 03-11-94	REVISED - K. SMITH 07-11-19

STATE OF ILLINOIS
DEPARTMENT OF TRANSPORTATION

CURB OR CURB AND GUTTER REMOVAL AND REPLACEMENT			
SCALE: NONE	SHEET 1 OF 1 SHEETS	STA. TO STA.	

F.A. RTE.	SECTION	COUNTY	TOTAL SHEETS	SHEET NO.
1479	14-00124-04-BR	DUPAGE	208	175
BD600-06 (BD-24)		CONTRACT NO. 61114		
ILLINOIS FED. AID PROJECT				

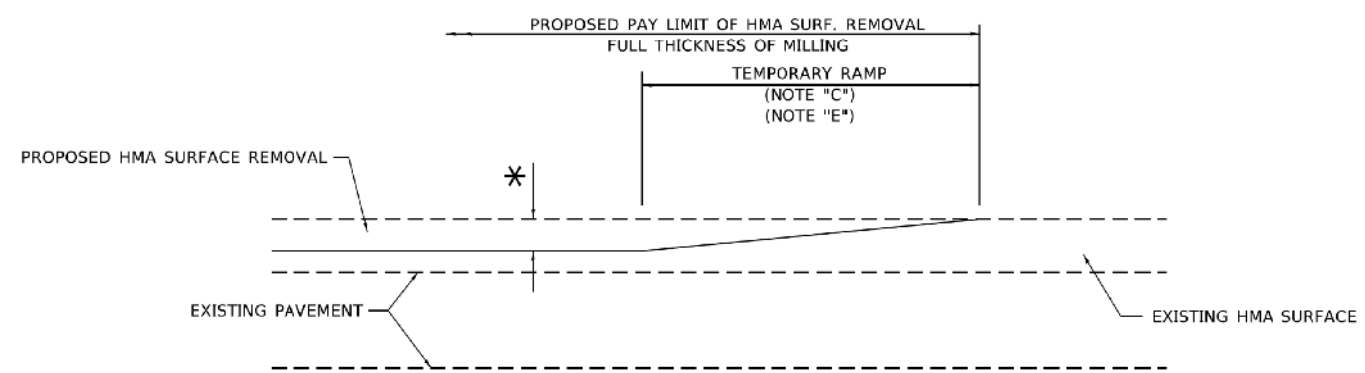

MILLED TEMPORARY RAMP
(FOR BUTT JOINT AND HMA TAPER SEE DETAIL BELOW)

OPTION 1

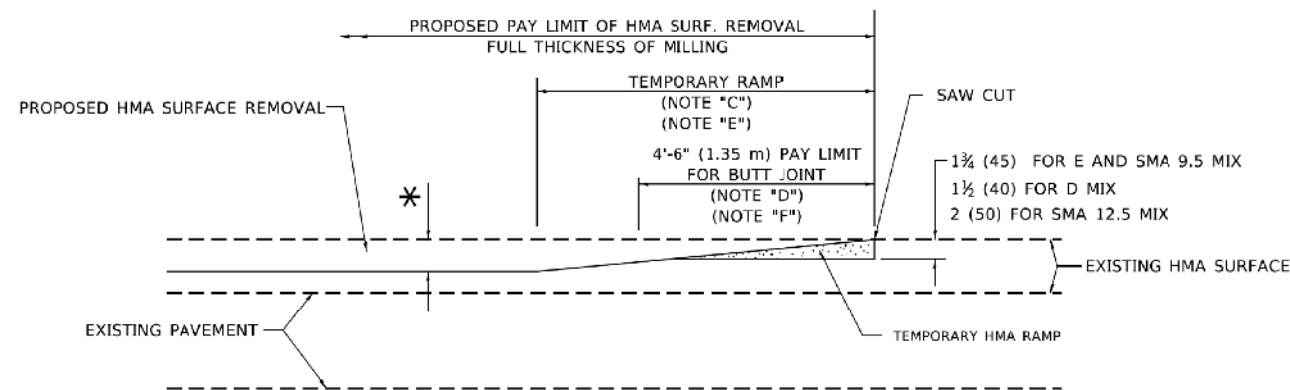

HMA CONSTRUCTED TEMPORARY RAMP
(FOR BUTT JOINT AND HMA TAPER SEE DETAIL BELOW)

OPTION 2

TYPICAL TEMPORARY RAMP

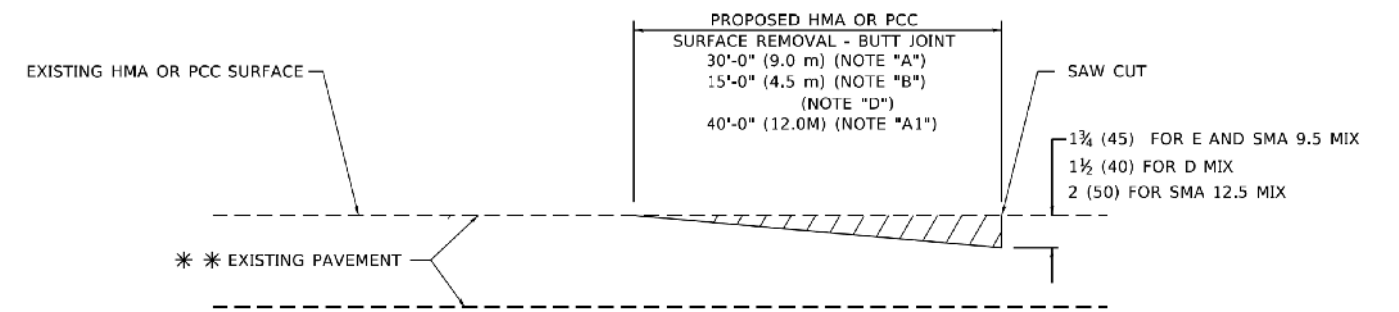

BUTT JOINT DETAIL

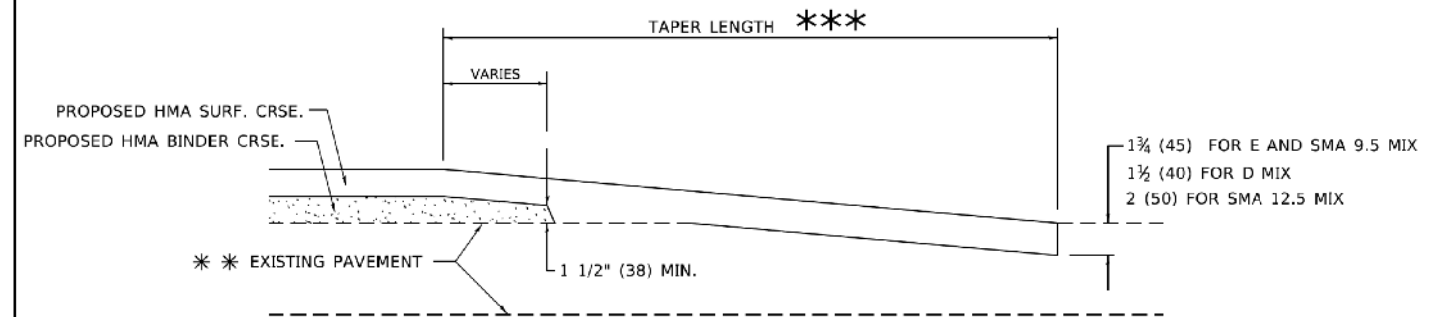

HMA TAPER DETAIL

TYPICAL BUTT JOINT AND HMA TAPER FOR RESURFACING ONLY

*** PC CONCRETE, HMA OR HMA RESURFACED PAVEMENT.

GENERAL NOTES

- A. MAINLINE ARTERIAL ROADWAYS AND MAJOR SIDE ROADS.
- A1. INTERSTATES
- B. MINOR SIDE ROADS.
- C. THE TEMP. RAMP SHALL BE CONSTRUCTED IMMEDIATELY UPON REMOVAL OF THE EXISTING HMA SURFACE.
- D. THE BUTT JOINT SHALL BE CONSTRUCTED IMMEDIATELY PRIOR TO PLACING THE PROPOSED HMA COURSES.
- E. TAPER THE TEMP. RAMP AT A RATE OF 3' - 4" (1.02m) PER 1 INCH (25 mm) OF MILLING THICKNESS.
* SEE TYPICAL SECTIONS FOR MILLING THICKNESS.
- F. SEE ARTICLE 406.08 AND 406.14 OF THE STANDARD SPECIFICATIONS FOR "HMA AND/OR PCC SURFACE REMOVAL, BUTT JOINT".
*** 20'-0" (6.1 m) PER 1 (25) RESURFACING (NOTE "A")
10'-0" (3.0 m) PER 1 (25) RESURFACING (NOTE "B")

BASIS OF PAYMENT

- 1. THE BUTT JOINT WILL BE PAID FOR AT THE CONTRACT UNIT PRICE PER SQUARE YARD (SQUARE METER) FOR "HOT-MIX ASPHALT SURFACE REMOVAL - BUTT JOINT" OR FOR "PORTLAND CEMENT CONCRETE SURFACE REMOVAL - BUTT JOINT".
- 2. THE TEMPORARY RAMP AND SAW CUT SHALL BE INCLUDED IN THE UNIT COST FOR HMA OR PCC SURFACE REMOVAL-BUTT JOINT.

ALL DIMENSIONS ARE IN INCHES (MILLIMETERS) UNLESS OTHERWISE SHOWN.

MODEL: J:\dtd\p...
 FILE: \p\1479...
 PROJECT: 1479...
 SHEET: 1479...

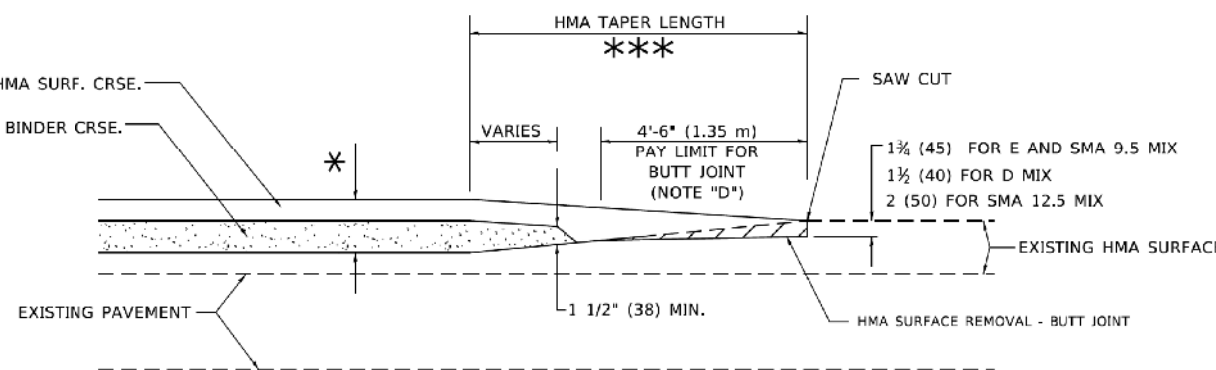

BUTT JOINT AND HMA TAPER

TYPICAL BUTT JOINT AND HMA TAPER FOR MILLING AND RESURFACING



USER NAME = Lawrence.DeManche	DESIGNED - M. DE YONG	REVISED - A. ABBAS 03-21-97
	DRAWN -	REVISED - M. GOMEZ 04-06-01
PLOT SCALE = 100,0000 1' = 1 in.	CHECKED -	REVISED - R. BORO 01-01-07
PLOT DATE = 11/18/2022	DATE - 06-13-90	REVISED - K. SMITH 11-18-22

STATE OF ILLINOIS
DEPARTMENT OF TRANSPORTATION

SCALE: NONE		SHEET 1 OF 1 SHEETS		STA. TO STA.	
-------------	--	---------------------	--	--------------	--

BUTT JOINT AND HMA TAPER DETAILS

F.A. RTE.	SECTION	COUNTY	TOTAL SHEETS	SHEET NO.
1479	14-00124-04-BR	DUPAGE	208	176
BD400-05 BD-32		CONTRACT NO. 61114		
ILLINOIS FED. AID PROJECT				

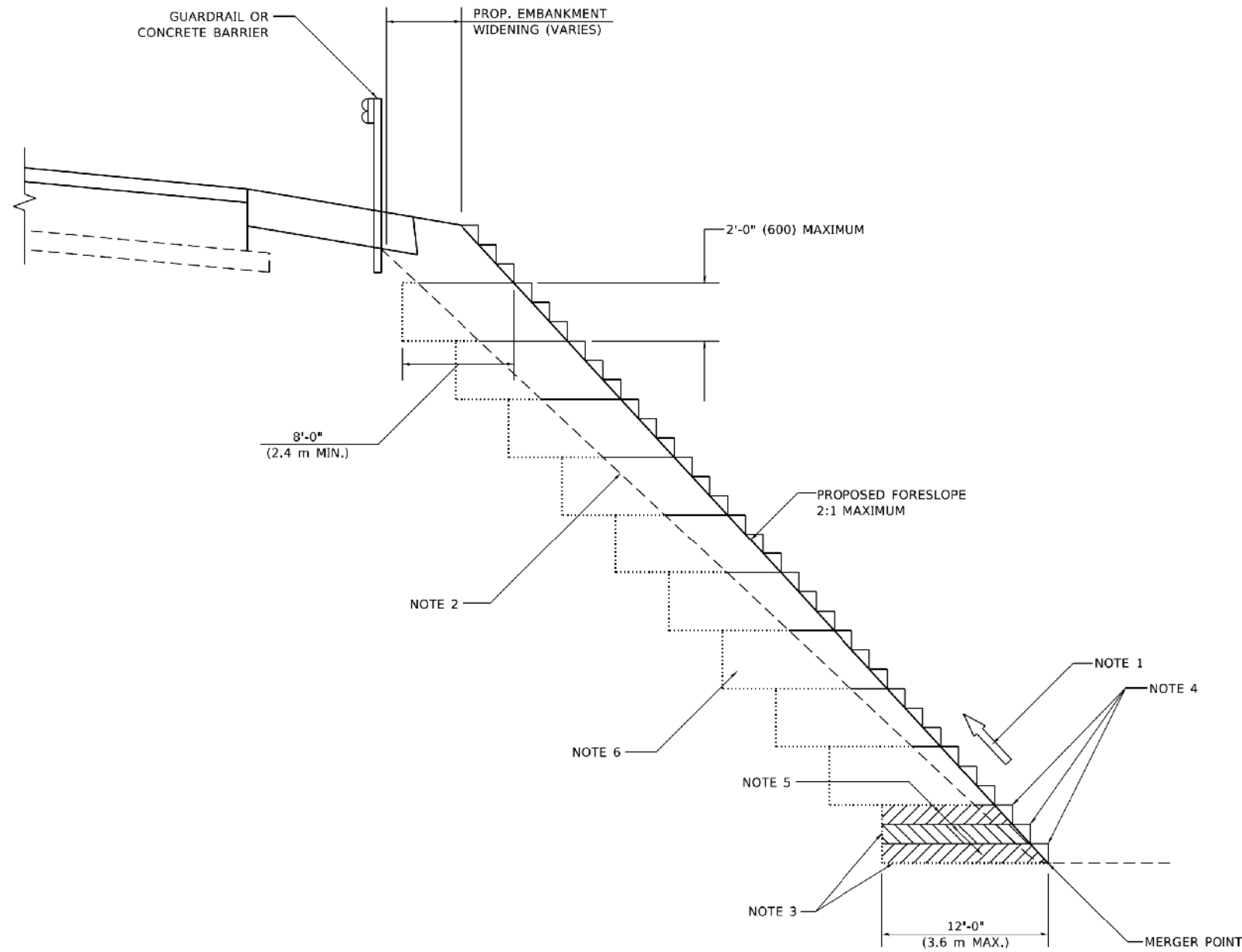

**TYPICAL BENCHING DETAIL
FOR EMBANKMENT**

GENERAL NOTES

1. CONSTRUCT SUCCEEDING BENCH CUTS AND EMBANKMENT PLACEMENT AND COMPACTION FROM BOTTOM TO TOP IN STAIRSTEP FASHION.
2. EXISTING FORESLOPE PREPARED IN ACCORDANCE WITH ARTICLE 205.03 OF THE STANDARD SPECIFICATIONS.
3. BENCH CUT EXISTING SLOPE TYPICAL FOR EACH STEP.
4. TRIM TO FINAL SLOPE.
5. EQUAL 8-INCH (200) LIFTS OF EMBANKMENT COMPACTED IN ACCORDANCE WITH ARTICLE 205.05 OF THE STANDARD SPECIFICATIONS.

BASIS OF PAYMENT

1. EXCAVATION OF BENCH CUTS WITHIN EXISTING EMBANKMENT WILL BE PAID FOR AT THE CONTRACT UNIT PRICE PER CUBIC METER OR CUBIC YARD FOR "EARTH EXCAVATION". THIS PRICE WILL INCLUDE ALL LABOR AND MATERIAL, NO ADDITIONAL COMPENSATION WILL BE ALLOWED.

ALL DIMENSIONS ARE IN INCHES (MILLIMETERS)
UNLESS OTHERWISE SHOWN.

MODEL: I:\dgn\14-00124-04-BR\14-00124-04-BR.dgn
 FILE: 14-00124-04-BR\14-00124-04-BR.dgn
 PLOT DATE: 11/18/2022



USER NAME = Lawrence.DeManche	DESIGNED -	REVISED - K. SMITH 11-18-22
	DRAWN - CADD	REVISED -
PLOT SCALE = 100.0000' / in.	CHECKED - S.E.B.	REVISED -
PLOT DATE = 11/18/2022	DATE - 06-16-04	REVISED -

**STATE OF ILLINOIS
DEPARTMENT OF TRANSPORTATION**

BENCHING DETAIL FOR EMBANKMENT WIDENING			
SCALE: NONE	SHEET 1	OF 1 SHEETS	STA. TO STA.

F.A. RTE.	SECTION	COUNTY	TOTAL SHEETS	SHEET NO.
1479	14-00124-04-BR	DUPAGE	208	177
BD-51			CONTRACT NO. 61114	
ILLINOIS FED. AID PROJECT				

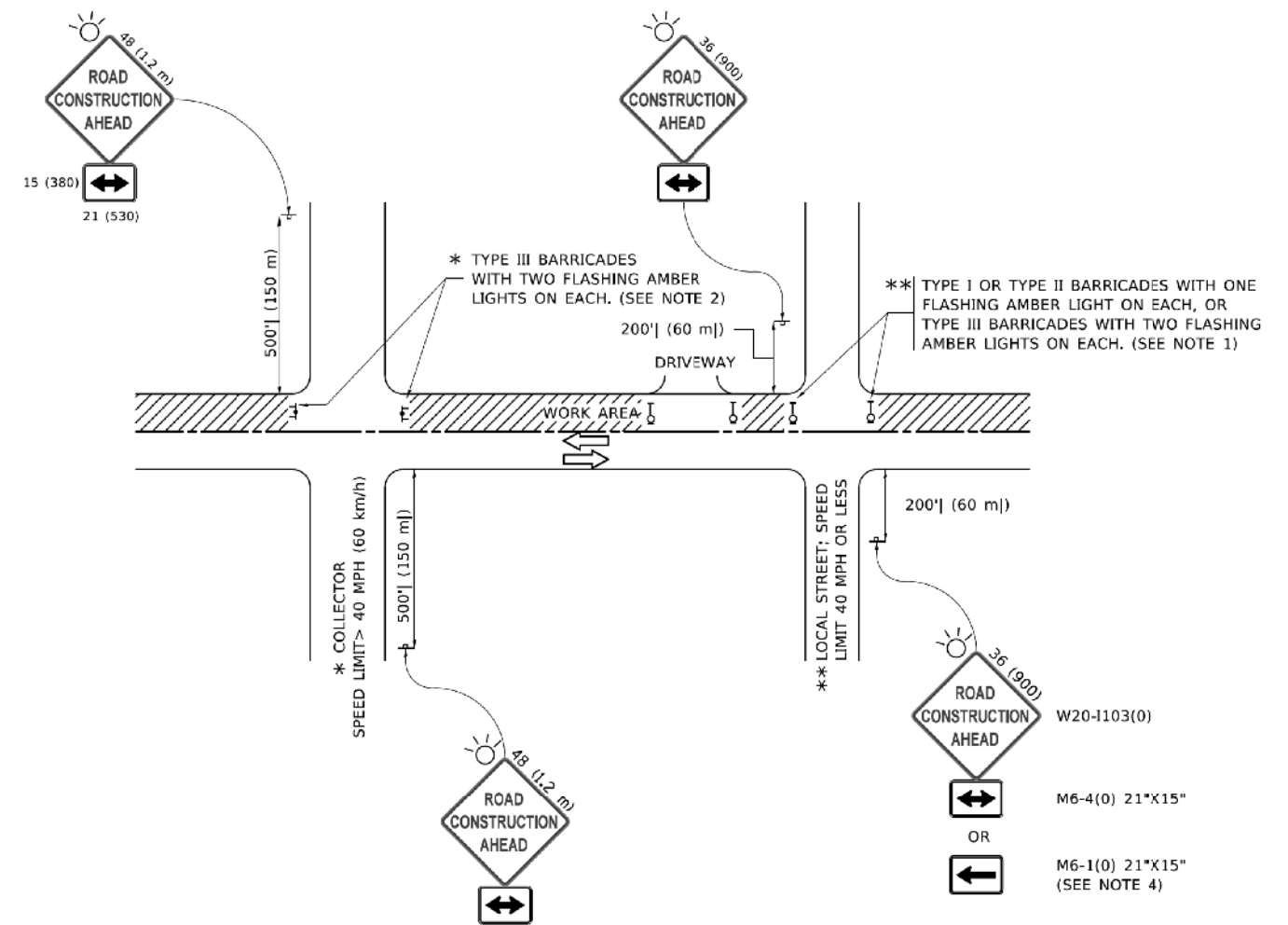

NOTES:

- SIDE ROAD WITH A SPEED LIMIT OF 40 MPH (60 km/h) OR LESS AS SHOWN ON THE DRAWING AND AS DIRECTED BY THE ENGINEER:
 - ONE "ROAD CONSTRUCTION AHEAD" SIGN 36 x 36 (900x900) WITH A FLASHER MOUNTED ON IT APPROXIMATELY 200' (60 m) IN ADVANCE OF THE MAIN ROUTE.
 - THE CLOSED PORTION OF THE MAIN ROUTE SHALL BE PROTECTED BY BLOCKING WITH TYPE I, TYPE II OR TYPE III BARRICADES, 1/3 OF THE CROSS SECTION OF THE CLOSED PORTION.
- SIDE ROAD WITH A SPEED LIMIT GREATER THAN 40 MPH (60 km/h) AS SHOWN ON THE DRAWING AND AS DIRECTED BY THE ENGINEER:
 - ONE "ROAD CONSTRUCTION AHEAD" SIGN 48 x 48 (1.2 m x 1.2 m) WITH A FLASHER MOUNTED ON IT APPROXIMATELY 500' (150 m) IN ADVANCE OF THE MAIN ROUTE.
THE CLOSED PORTION OF THE MAIN ROUTE SHALL BE PROTECTED BY BLOCKING WITH TYPE III BARRICADES, 1/2 OF THE CROSS SECTION OF THE CLOSED PORTION.
- CONES MAY BE SUBSTITUTED FOR BARRICADES OR DRUMS AT HALF THE SPACING DURING DAY OPERATIONS. CONES SHALL BE A MINIMUM OF 28 (710) IN HEIGHT.
- SIGNING AND THE WORK ZONE, A SINGLE HEADED ARROW (M6-1) SHALL BE USED IN LIEU OF THE DOUBLE HEADED ARROW (M6-4).
- WHEN WORK IS BEING PERFORMED ON A SIDE ROAD OR DRIVEWAY, FOLLOW THE APPLICABLE STANDARD(S). THE DIRECTIONAL ARROW (M6-1 OR M6-4) SHALL BE COVERED OR REMOVED WHEN NO LONGER CONSISTENT WITH THE TRAFFIC CONTROL SET-UP.
- ADVANCE WARNING SIGNS ARE TO BE OMITTED ON DRIVEWAYS UNLESS OTHERWISE SPECIFIED IN THE PLANS OR BY THE ENGINEER.
- THE TRAFFIC CONTROL AND PROTECTION FOR SIDE ROADS, INTERSECTIONS, AND DRIVEWAYS SHALL BE INCLUDED IN THE COST OF SPECIFIED TRAFFIC CONTROL STANDARDS OR ITEMS.

All dimensions are in inches (millimeters) unless otherwise shown.

MODEL: D:\cfs\p\...
FILE: I:\STATE\PROJECTS\1400124\04-BR\1400124-04-BR-TCP\1400124-04-BR-TCP-SHEETS\1400124-04-BR-TCP-SHEETS-178.dwg

KNIGHT Member of WSP	USER NAME = focteml	DESIGNED - L.H.A.	REVISED - A. HOUSEH 10-15-96
	PLOT SCALE = 50.0000' / in.	DRAWN -	REVISED - T. RAMMACHER 01-06-00
	PLOT DATE = 3/4/2019	CHECKED -	REVISED - A. SCHUETZE 07-01-13
		DATE - 06-89	REVISED - A. SCHUETZE 09-15-16

**STATE OF ILLINOIS
DEPARTMENT OF TRANSPORTATION**

**TRAFFIC CONTROL AND PROTECTION FOR
SIDE ROADS, INTERSECTIONS, AND DRIVEWAYS**

SCALE: NONE SHEET 1 OF 1 SHEETS STA. TO STA.

F.A. RTE.	SECTION	COUNTY	TOTAL SHEETS	SHEET NO.
1479	14-00124-04-BR	DUPAGE	208	178
TC-10			CONTRACT NO. 61114	
ILLINOIS FED. AID PROJECT				

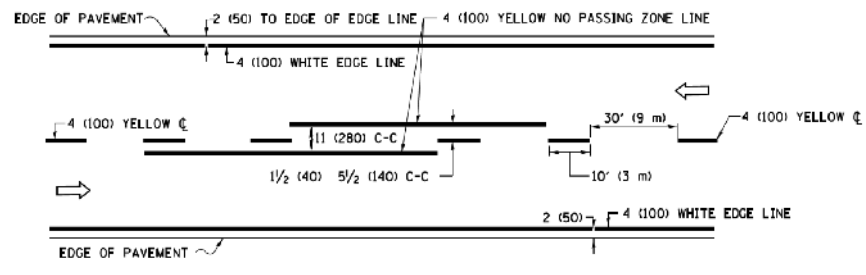

2-LANE ROADWAY

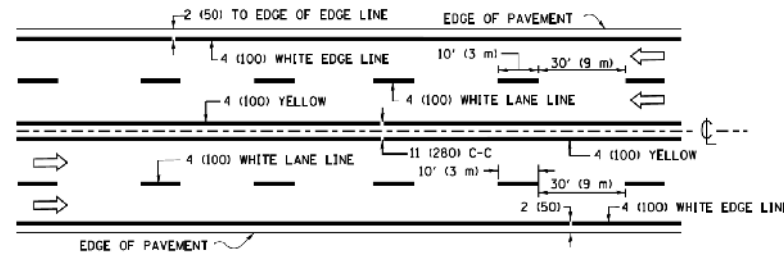

MULTI-LANE UNDIVIDED

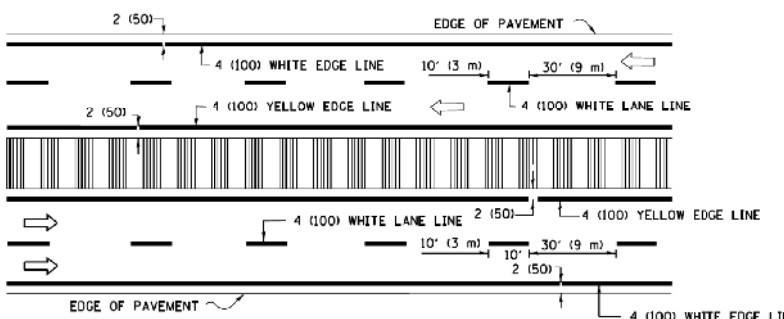

MULTI-LANE DIVIDED WITH MEDIAN

TYPICAL LANE AND EDGE LINE MARKING

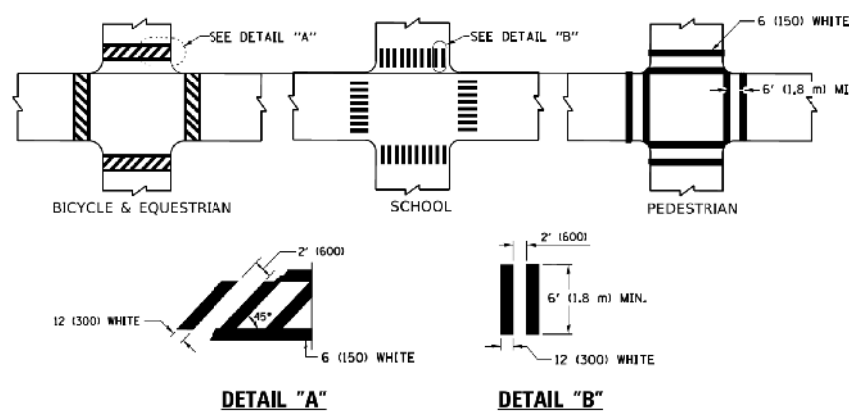

TYPICAL CROSSWALK MARKING

* MARKINGS SHALL BE INSTALLED PARALLEL TO THE CENTERLINE OF THE ROAD WHICH IT CROSSES

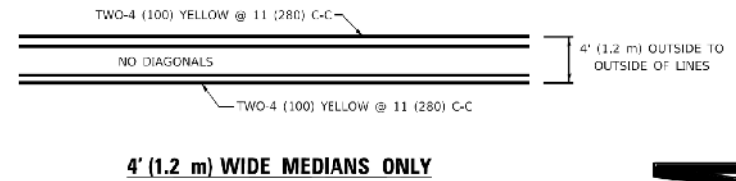

4' (1.2 m) WIDE MEDIANS ONLY

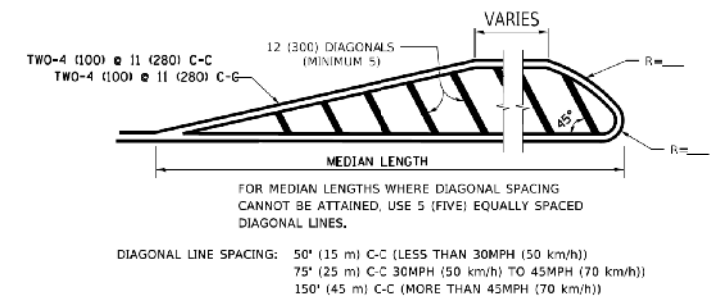

MEDIANS OVER 4' (1.2 m) WIDE

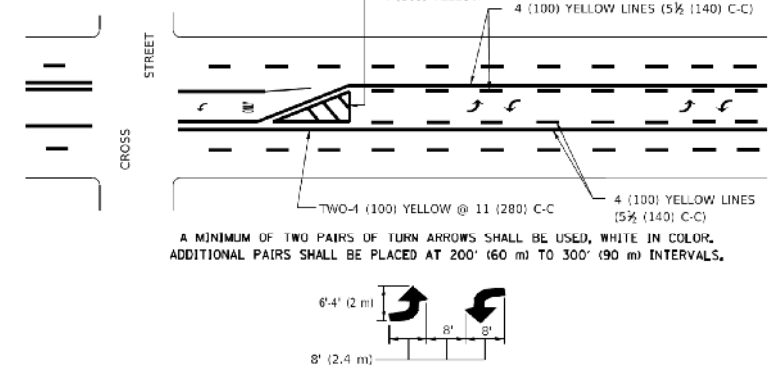

MEDIAN WITH TWO-WAY LEFT TURN LANE

TYPICAL PAINTED MEDIAN MARKING

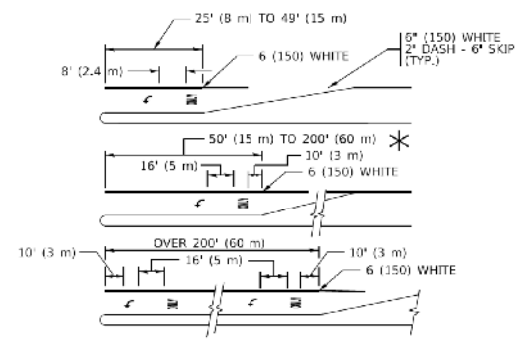

TYPICAL LEFT (OR RIGHT) TURN LANE

TYPICAL TURN LANE MARKING

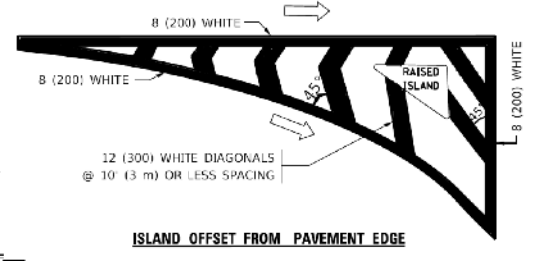

ISLAND OFFSET FROM PAVEMENT EDGE

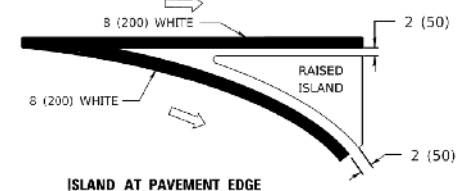

ISLAND AT PAVEMENT EDGE

TYPICAL ISLAND MARKING

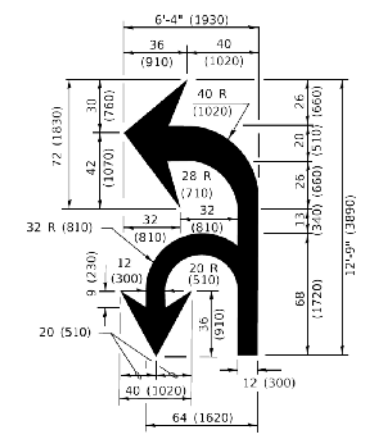

COMBINATION LEFT AND U-TURN

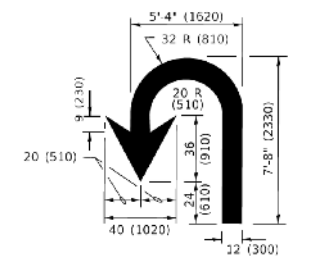

U-TURN

LANE REDUCTION TRANSITION

* LANE REDUCTION ARROWS REQUIRED AT SPEEDS OF 45 MPH OR GREATER OR WHEN SPECIFIED IN PLANS.

D(FT)	SPEED LIMIT
345	30
425	35
500	40
580	45
665	50
750	55

TYPE OF MARKING	WIDTH OF LINE	PATTERN	COLOR	SPACING / REMARKS
CENTERLINE ON 2 LANE PAVEMENT	4 (100)	SKIP-DASH	YELLOW	10' (3 m) LINE WITH 30' (9 m) SPACE
CENTERLINE ON MULTI-LANE UNDIVIDED PAVEMENT	2 @ 4 (100)	SOLID	YELLOW	11 (280) C-C
NO PASSING ZONE LINES: FOR ONE DIRECTION FOR BOTH DIRECTIONS	4 (100) 2 @ 4 (100)	SOLID SOLID	YELLOW YELLOW	5 1/2 (140) C-C FROM SKIP-DASH CENTERLINE 11 (280) C-C OMIT SKIP-DASH CENTERLINE BETWEEN
LANE LINES	4 (100) 5 (125) ON FREEWAYS	SKIP-DASH SKIP-DASH	WHITE WHITE	10' (3 m) LINE WITH 30' (9 m) SPACE
DOTTED LINES (EXTENSIONS OF CENTER, LANE OR TURN LANE MARKINGS)	SAME AS LINE BEING EXTENDED	SKIP-DASH	SAME AS LINE BEING EXTENDED	2' (600) LINE WITH 6' (1.8 m) SPACE
EDGE LINES	4 (100)	SOLID	YELLOW-LEFT WHITE-RIGHT	OUTLINE MEDIANS IN YELLOW
TURN LANE MARKINGS	6 (150) LINE; FULL SIZE LETTERS & SYMBOLS (8' (2.4m))	SOLID	WHITE	SEE TYPICAL TURN LANE MARKING DETAIL
TWO WAY LEFT TURN MARKING	2 @ 4 (100) EACH DIRECTION 8' (2.4m) LEFT ARROW	SKIP-DASH AND SOLID IN PAIRS	YELLOW WHITE	10' (3 m) LINE WITH 30' (9 m) SPACE FOR SKIP-DASH; 5 1/2 (140) C-C BETWEEN SOLID LINE AND SKIP-DASH LINE SEE TYPICAL TWO-WAY LEFT TURN MARKING DETAIL
CROSSWALK LINES (PEDESTRIAN) A. DIAGONALS (BIKE & EQUESTRIAN) B. LONGITUDINAL BARS (SCHOOL)	2 @ 6 (150) 12 (300) @ 45° 12 (300) @ 90°	SOLID SOLID SOLID	WHITE WHITE WHITE	NOT LESS THAN 6' (1.8 m) APART 2' (600) APART 2' (600) APART SEE TYPICAL CROSSWALK MARKING DETAILS.
STOP LINES	24 (600)	SOLID	WHITE	PLACE 4' (1.2 m) IN ADVANCE OF AND PARALLEL TO CROSSWALK, IF PRESENT. OTHERWISE, PLACE AT DESIRED STOPPING POINT. PARALLEL TO CROSSROAD CENTERLINE, WHERE POSSIBLE.
PAINTED MEDIANS	2 @ 4 (100) WITH 12 (300) DIAGONALS @ 45° NO DIAGONALS USED FOR 4' (1.2 m) WIDE MEDIANS	SOLID	YELLOW: TWO WAY TRAFFIC WHITE: ONE WAY TRAFFIC	11 (280) C-C FOR THE DOUBLE LINE SEE TYPICAL PAINTED MEDIAN MARKING.
GORE MARKING AND CHANNELIZING LINES	8 (200) WITH 12 (300) DIAGONALS @ 45°	SOLID	WHITE	DIAGONALS: 15' (4.5 m) C-C (LESS THAN 30MPH (50 km/h)) 20' (6 m) C-C 30MPH (50 km/h) TO 45MPH (70 km/h) 30' (9 m) C-C (OVER 45MPH (70 km/h))
RAILROAD CROSSING	24 (600) TRANSVERSE LINES: "RR" 15' (4.5 m) LETTERS: 16 (400) LINE FOR "X"	SOLID	WHITE	SEE STATE STANDARD 780001 AREA OF: "R"=3.6 SQ. FT. (0.33 m ²) EACH "X"=54.0 SQ. FT. (5.0 m ²)
SHOULDER DIAGONALS (REQUIRED FOR SHOULDERS ≥ 8')	12 (300) @ 45°	SOLID	WHITE - RIGHT YELLOW - LEFT	50' (15 m) C-C (LESS THAN 30MPH (50 km/h)) 75' (25 m) C-C 30 MPH (50 km/h) TO 45MPH (70 km/h) 150' (45 m) C-C (OVER 45MPH (70 km/h))
U TURN ARROW	SEE DETAIL	SOLID	WHITE	16.3 SF
2 ARROW COMBINATION LEFT AND U TURN	SEE DETAIL	SOLID	WHITE	30.4 SF

FOR FURTHER DETAILS ON PAVEMENT MARKING REFER TO STANDARD SPECIFICATIONS FOR ROAD AND BRIDGE CONSTRUCTION AND STATE STANDARD 780001.

All dimensions are in inches (millimeters) unless otherwise shown.

MODEL: D:\p1\p1.dwg
FILE: TYPICAL PAVEMENT MARKINGS.dwg
PROJECT: ILLINOIS STATE DEPARTMENT OF TRANSPORTATION
DRAWN BY: JUCIUS
DATE: 03/19/2019

KNIGHT
Member of WSP

USER NAME - footem	DESIGNED - EVERS	REVISED - C. JUCIUS 09-09-09
PLOT SCALE = 50.0000" / 1'	DRAWN -	REVISED - C. JUCIUS 07-01-13
PLOT DATE = 3/4/2019	CHECKED -	REVISED - C. JUCIUS 12-21-15
	DATE - 03-19-90	REVISED - C. JUCIUS 04-12-16

STATE OF ILLINOIS
DEPARTMENT OF TRANSPORTATION

DISTRICT ONE
TYPICAL PAVEMENT MARKINGS

SCALE: NONE SHEET 1 OF 1 SHEETS STA. TO STA.

F.A. RTE.	SECTION	COUNTY	TOTAL SHEETS	SHEET NO.
1479	14-00124-04-BR	DUPAGE	208	179
TC-13			CONTRACT NO. 61114	

ILLINOIS FED. AID PROJECT

TURN BAY ENTRANCE AT START OF LANE CLOSURE TAPER

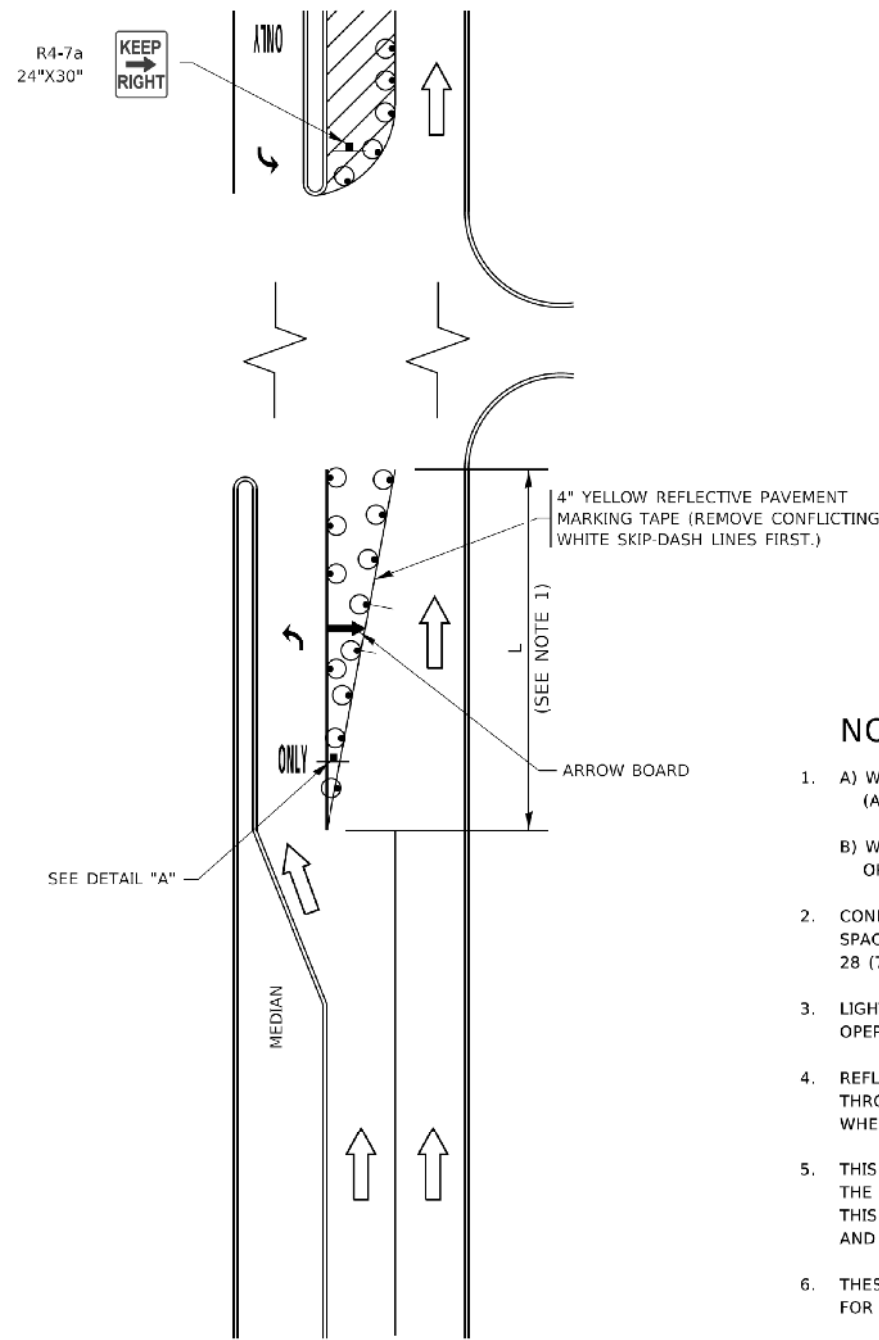

FIGURE 1

TURN BAY ENTRANCE WITHIN A LANE CLOSURE

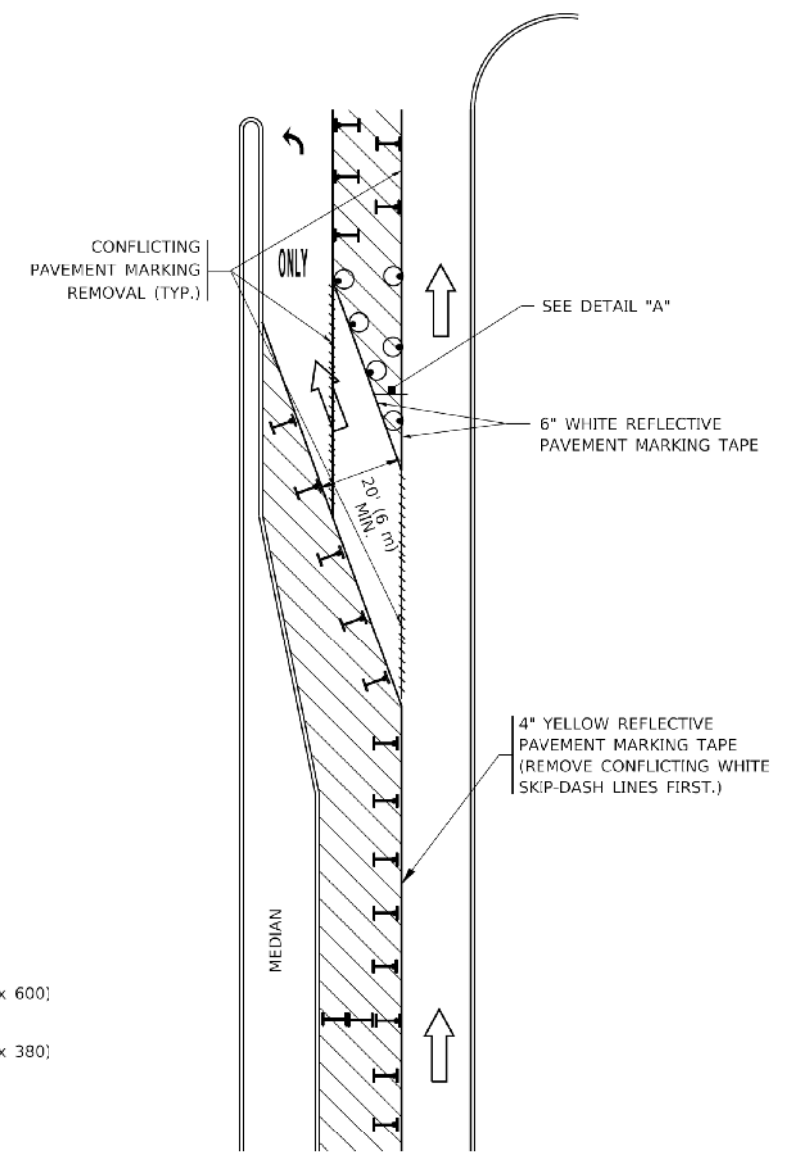

FIGURE 2

LEGEND

- WORK AREA
- LANE OPEN TO TRAFFIC
- ARROW BOARD
- TYPE I OR II BARRICADE OR DRUM WITH STEADY BURN LIGHT
- DRUM WITH STEADY BURN LIGHT
- SIGN ASSEMBLY
- TYPE I OR II CHECK BARRICADE WITH FLASHING LIGHT

NOTES:

1. A) WHEN "L" IS \leq THE STORAGE LENGTH OF THE TURN LANE (AS SHOWN IN FIG. 1), USE FIGURE 1.
B) WHEN "L" IS $>$ THE STORAGE LENGTH OF THE TURN LANE OR THE TURN LANE IS WITHIN THE LANE CLOSURE, USE FIGURE 2.
2. CONES MAY BE SUBSTITUTED FOR BARRICADES OR DRUMS AT HALF THE SPACING DURING DAY OPERATIONS. CONES SHALL BE A MINIMUM OF 28 (710) IN HEIGHT.
3. LIGHTS WILL NOT BE REQUIRED ON BARRICADES OR DRUMS FOR DAY OPERATIONS. ALL LIGHTS SHALL BE MONODIRECTIONAL.
4. REFLECTIVE TEMPORARY PAVEMENT MARKINGS SHALL BE PLACED THROUGHOUT THE BARRICADED AREAS OF EACH TURN BAY AS SHOWN WHERE THE CLOSURE TIME IS GREATER THAN FOURTEEN (14) DAYS.
5. THIS APPLICATION ALSO APPLIES WHEN WORK IS BEING PERFORMED IN THE RIGHT LANE(S) AND THE RIGHT TURN BAY IS TO REMAIN OPEN. UNDER THIS CONDITION, "RIGHT TURN LANE" R3-1100R 24 x 24 (600 x 600) AND M6-2R 21 x 15 (530 x 380) SHALL BE USED.
6. THESE CONTROLS SHALL SUPPLEMENT MAINLINE TRAFFIC CONTROL FOR LANE CLOSURES.
7. THE SIGNS SHALL BE MOUNTED ABOVE THE BARRICADES/DRUMS ON SEPARATE SIGN SUPPORTS THAT MEET NCHRP 350 OR MASH REQUIREMENTS.
8. TRAFFIC CONTROL AND PROTECTION AT TURN BAYS (TO REMAIN OPEN TO TRAFFIC) SHALL BE INCLUDED IN THE COST OF SPECIFIED TRAFFIC CONTROL STANDARDS OR ITEMS.

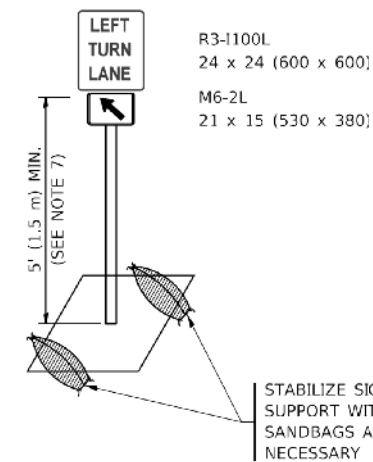

DETAIL A

All dimensions are in inches (millimeters) unless otherwise shown.

MODEL: D:\p1\14-00124-04-01\14-00124-04-01.dwg

KNIGHT
Member of WSP

USER NAME = foctem	DESIGNED - T. RAMMACHER 09-08-94	REVISED - R. BORO 09-14-09
	DRAWN - A. HOUSEH 11-07-95	REVISED - A. SCHUETZE 07-01-13
PLOT SCALE = 50.0000' / in.	CHECKED - A. HOUSEH 10-12-96	REVISED - A. SCHUETZE 09-15-16
PLOT DATE = 3/4/2019	DATE - T. RAMMACHER 01-06-00	REVISED -

STATE OF ILLINOIS
DEPARTMENT OF TRANSPORTATION

TRAFFIC CONTROL AND PROTECTION AT TURN BAYS
(TO REMAIN OPEN TO TRAFFIC)

SCALE: NONE SHEET 1 OF 1 SHEETS STA. TO STA.

F.A. RTE.	SECTION	COUNTY	TOTAL SHEETS	SHEET NO.
1479	14-00124-04-BR	DUPAGE	208	180
TC-14			CONTRACT NO. 61114	
ILLINOIS FED. AID PROJECT				

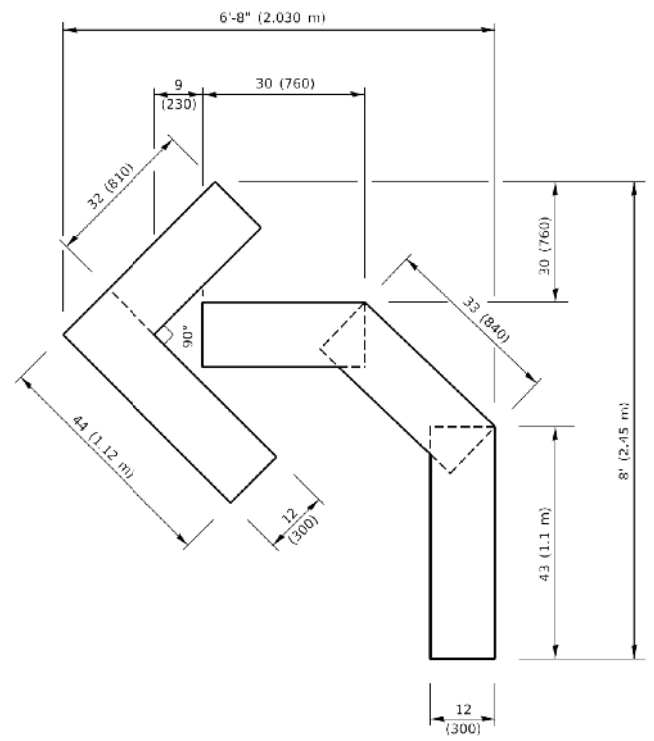

QUANTITY
 4 (100) LINE = 45.5 ft. (13.9 m)
 15.2 sq. ft. (1.41 sq. m)

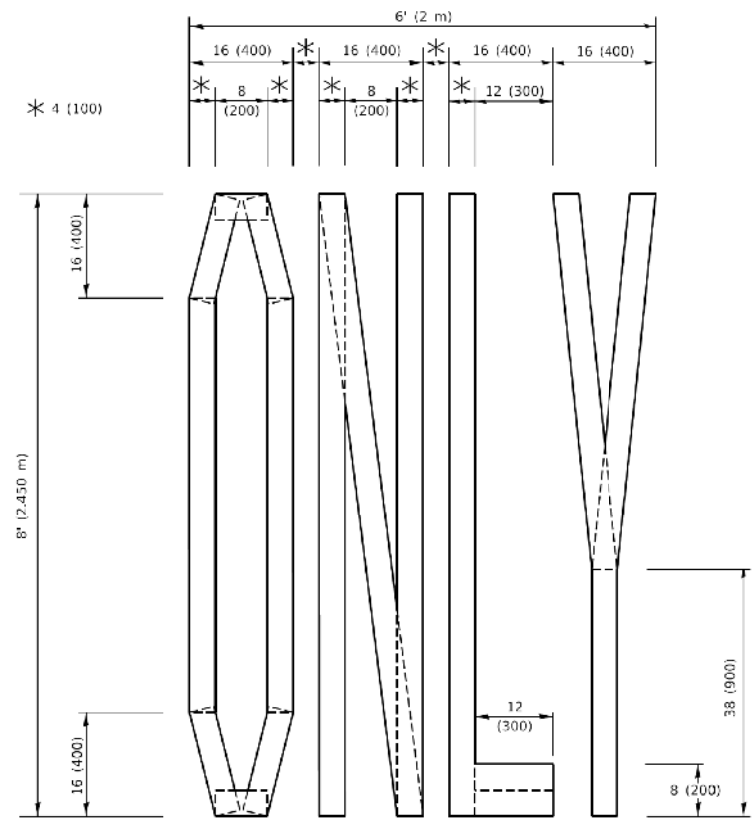

QUANTITY
 4 (100) LINE = 64.1 ft. (19.5 m)
 21.4 sq. ft. (1.99 sq. m)

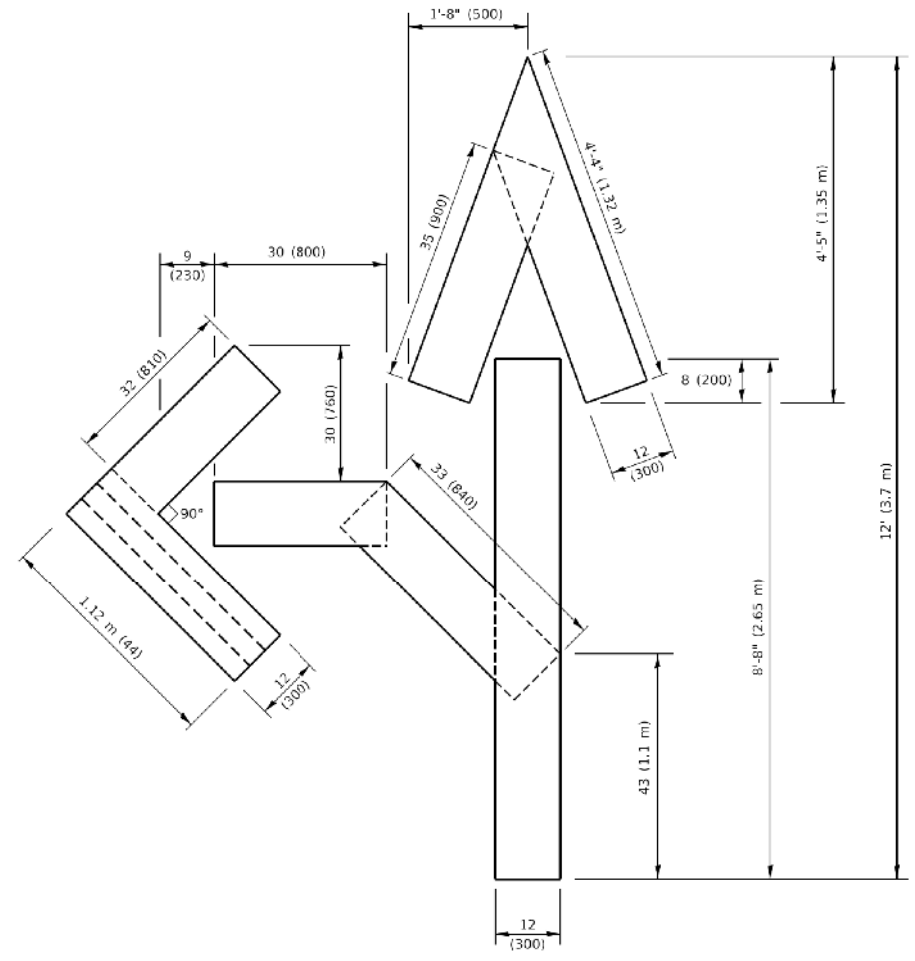

QUANTITY
 4 (100) LINE = 82.5 ft. (25.1 m)
 27.5 sq. ft. (2.53 sq. m)

NOTE:
 ALL QUANTITIES OF PLACEMENT ARE REPRESENTED IN LINEAR FEET OF 4" LINES TO MATCH THE 4" TEMPORARY TAPE PAY ITEM AND REPRESENTS THE TOTAL QUANTITY OF 4" TAPE REQUIRED.

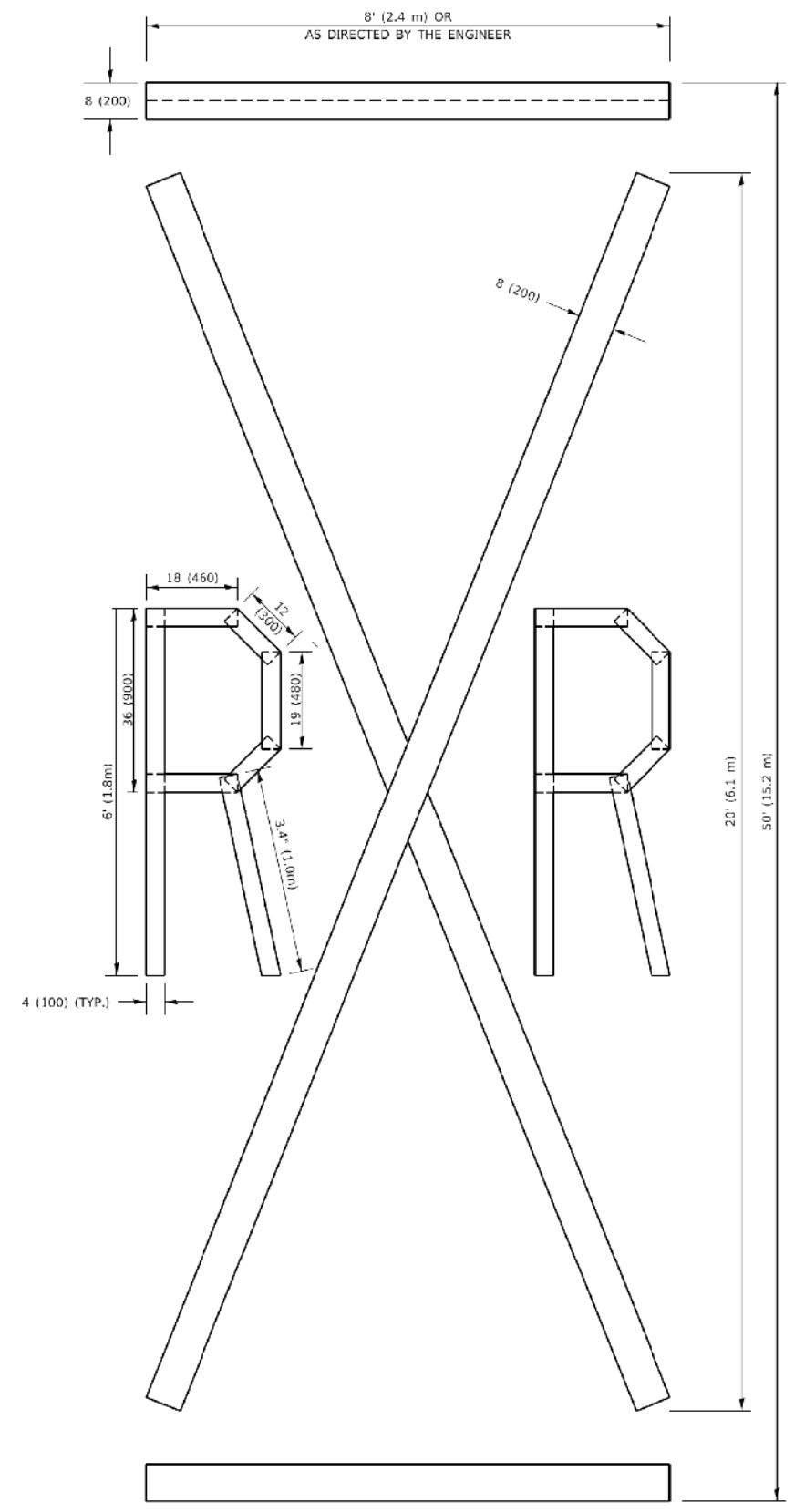

QUANTITY
 4 (100) LINE = 225.9 ft. (68.9 m)
 75.3 sq. ft. (6.99 sq. m)

All dimensions are in inches (millimeters) unless otherwise shown.

MODEL: D:\dell\...
 PLOT DATE = 3/4/2019



USER NAME = f006e[m]	DESIGNED -	REVISED - T. RAMMACHER 03-02-98
PLOT SCALE = 50.0268 1/ In.	DRAWN -	REVISED - E. GOMEZ 08-28-00
PLOT DATE = 3/4/2019	CHECKED -	REVISED - E. GOMEZ 08-28-00
	DATE - 09-18-94	REVISED - A. SCHUETZE 09-15-16

**STATE OF ILLINOIS
 DEPARTMENT OF TRANSPORTATION**

SHORT TERM PAVEMENT MARKING LETTERS AND SYMBOLS

SCALE: NONE SHEET 1 OF 1 SHEETS STA. TO STA.

F.A. RTE.	SECTION	COUNTY	TOTAL SHEETS	SHEET NO.
1479	14-00124-04-BR	DUPAGE	208	181
TC-16		CONTRACT NO. 61114		
ILLINOIS FED. AID PROJECT				

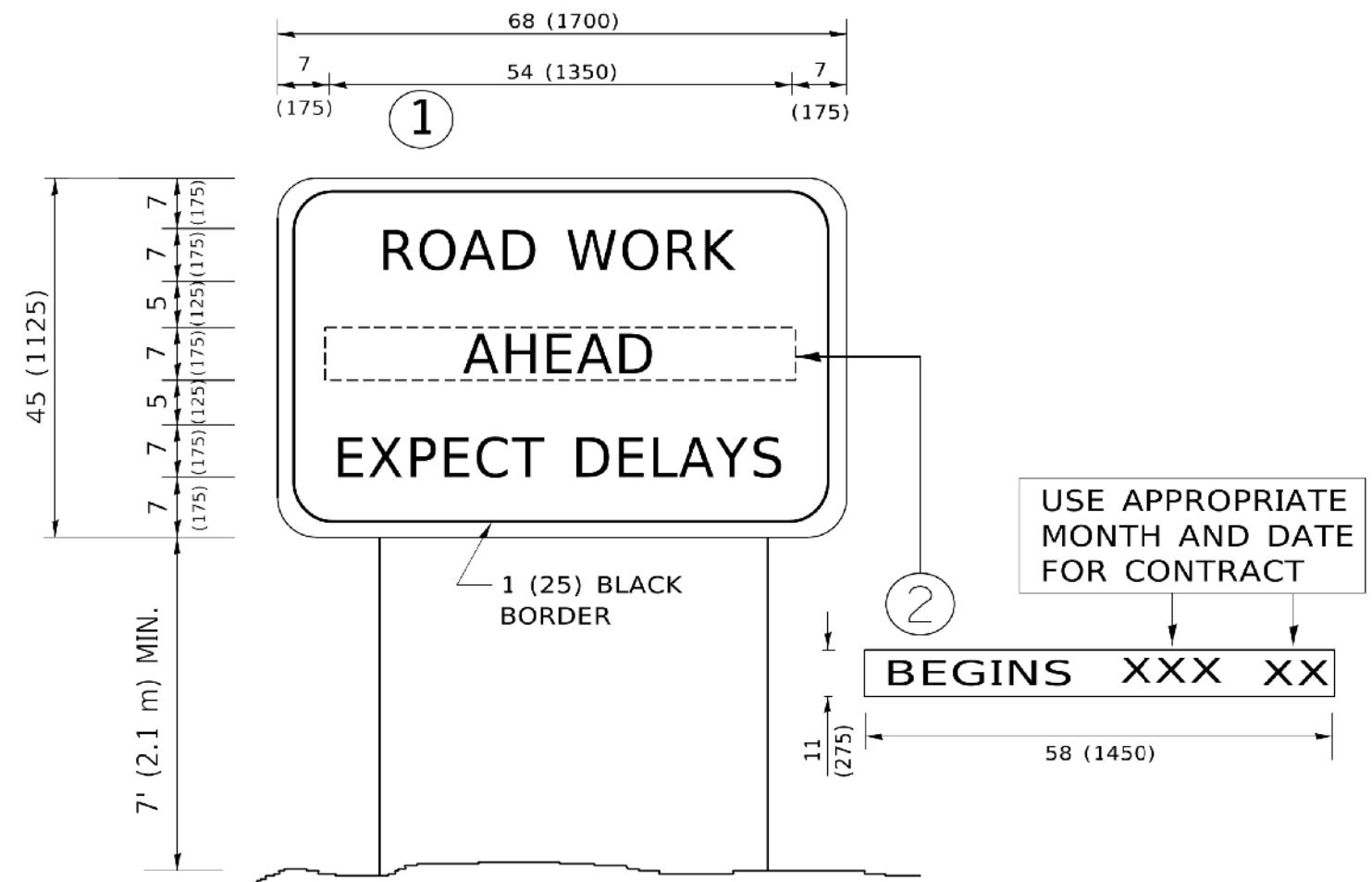

NOTES:

1. USE BLACK LETTERING ON ORANGE BACKGROUND.
2. ERECT SIGNS IN ADVANCE OF THE LOCATION FOR THE "ROAD CONSTRUCTION AHEAD" SIGN AT LOCATIONS AS DIRECTED BY THE ENGINEER.
3. ERECT SIGN ① WITH INSTALLED PANEL ② ONE WEEK PRIOR TO THE START OF CONSTRUCTION.
4. REMOVE PANEL ② SOON AFTER THE START OF CONSTRUCTION.
5. SEE SPECIAL PROVISION FOR "TEMPORARY INFORMATION SIGNING" FOR ADDITIONAL INFORMATION.
6. ONE SIGN ASSEMBLY EQUALS 25.70 SQ. FT. (2.3 SQ. M.)
7. SHALL BE PAID FOR AS TEMPORARY INFORMATION SIGNING.

ALL DIMENSIONS ARE IN INCHES (MILLIMETERS) UNLESS OTHERWISE SHOWN.

MODEL: D:\info\p...
 FILE: D:\info\p...

 Member of WSP	USER NAME = foctem	DESIGNED -	REVISED - R. MIRS 09-15-97	STATE OF ILLINOIS DEPARTMENT OF TRANSPORTATION	ARTERIAL ROAD INFORMATION SIGN		F.A. RTE.	SECTION	COUNTY	TOTAL SHEETS	SHEET NO.
	PLOT SCALE = 50.0000' / 1"	CHECKED -	REVISED - T. RAMMACHER 02-02-99				1479	14-00124-04-BR	DUPAGE	208	182
PLOT DATE = 3/4/2019	DATE -	REVISED - C. JUCIUS 01-31-07			SCALE: NONE	SHEET 1 OF 1 SHEETS	STA.	TO STA.	TC-22 ILLINOIS FED. AID PROJECT		CONTRACT NO. 61114

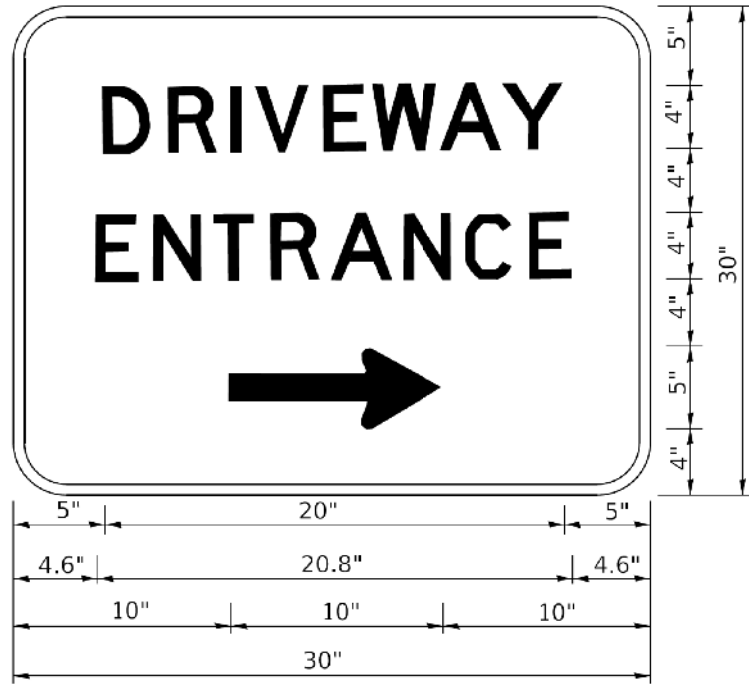

3.0" RADIUS, 0.5" BORDER, WHITE ON GREEN; REFLECTORIZED
 "DRIVEWAY" D; "ENTRANCE" D; STANDARD ARROW CUSTOM 12.0" x 5.0"

NOTES:

1. HALF OF THE SIGNS WILL REQUIRE A LEFT HAND FACING ARROW.
2. TWO SIGNS SHALL BE USED AT EACH COMMERCIAL ENTRANCE
 PLACED BACK-TO-BACK: ONE WITH A RIGHT HAND ARROW (SHOWN)
 SHALL BE PLACED ON THE NEAR RIGHT SIDE THE DRIVEWAY
 AND ONE WITH A LEFT HAND ARROW SHALL BE PLACED ON THE
 FAR LEFT SIDE OF THE DRIVEWAY.
3. SIGNS TO BE PAID FOR AS ITEM "TEMPORARY INFORMATION SIGNING".

MODEL: D:\proj\14-00124-04-DRIVEWAY\14-00124-04-DRIVEWAY_SIGNING.dgn
 FILE: D:\proj\14-00124-04-DRIVEWAY\14-00124-04-DRIVEWAY_SIGNING.dgn



USER NAME = foctemj	DESIGNED -	REVISED - C. JUCIUS 02-15-07
PLOT SCALE = 50.0000 ' / in.	DRAWN -	REVISED -
PLOT DATE = 3/4/2019	CHECKED -	REVISED -
	DATE -	REVISED -

STATE OF ILLINOIS
 DEPARTMENT OF TRANSPORTATION

DRIVEWAY ENTRANCE SIGNING

SCALE: NONE SHEET 1 OF 2 SHEETS STA. TO STA.

F.A. RTE.	SECTION	COUNTY	TOTAL SHEETS	SHEET NO.
1479	14-00124-04-BR	DUPAGE	208	183
TC-26				CONTRACT NO. 61114
ILLINOIS FED. AID PROJECT				

FINAL SURVEY NO.	BY	DATE
SURVEYED		
PLOTTED		
TEMPLATE		
AREAS		
AREAS CHECKED		

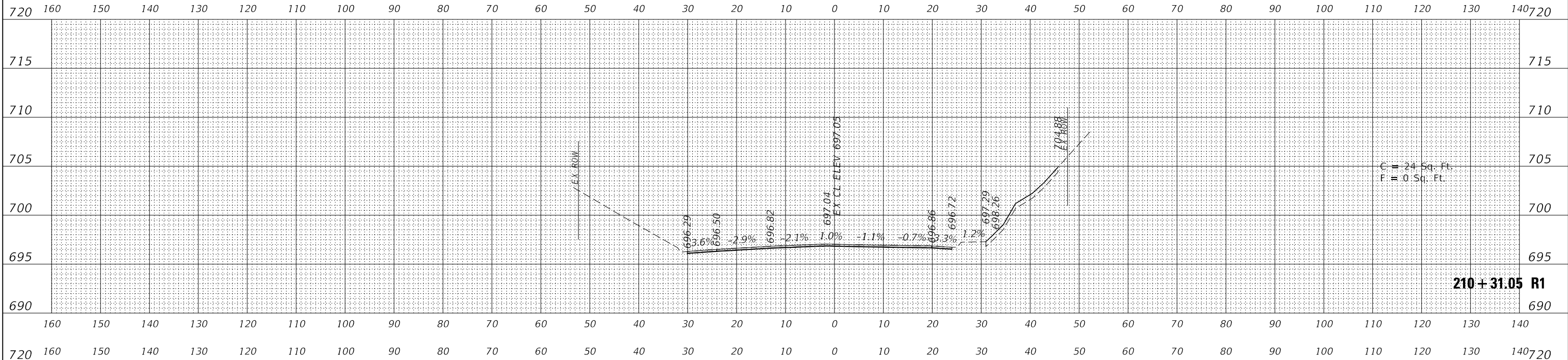

ORIGINAL SURVEY NO.	BY	DATE
SURVEYED		
PLOTTED		
TEMPLATE		
AREAS		
AREAS CHECKED		

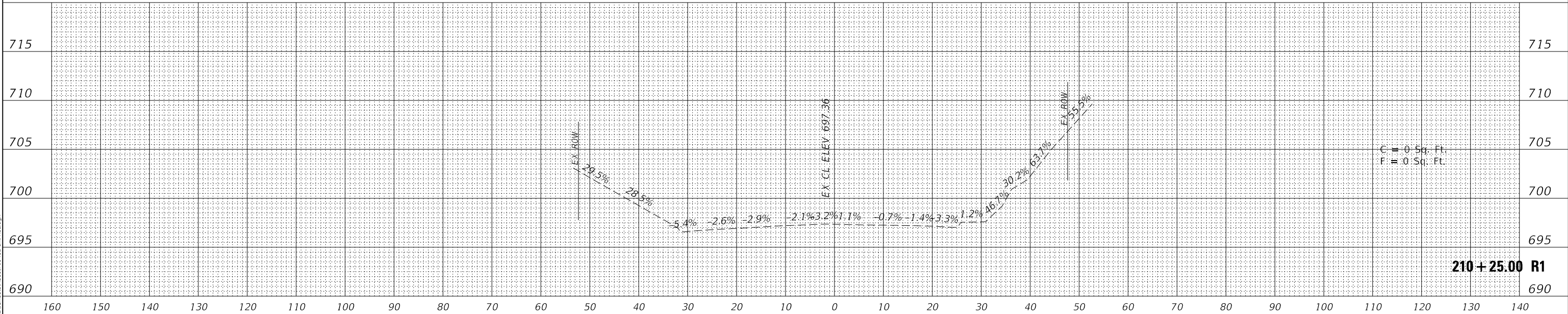

MODEL: \$MODELNAME\$
FILE NAME: I:\14-00124\Drawings\Sheet\19-02-210+25.00.dwg



USER NAME = USZE706065
PLOT SCALE = 1"=10' H : 1"=5' V
PLOT DATE = 2/8/2024

DESIGNED - D.M.S.
DRAWN - D.M.S.
CHECKED - J.R.S.
DATE - 8/12/22

REVISED -
REVISED -
REVISED -
REVISED -

STATE OF ILLINOIS
DEPARTMENT OF TRANSPORTATION

PROPOSED CROSS SECTIONS
WARRENVILLE ROAD

SCALE: 20 SHEET 1 OF 14 SHEETS STA. 210+25.00 R1 TO STA. 210+31.05 R1

F.A. RTE.	SECTION	COUNTY	TOTAL SHEETS	SHEET NO.
1479	14-00124-04-BR	DUPAGE	208	184
CONTRACT NO. 61114				
ILLINOIS		FED. AID PROJECT		

DATE	
BY	
SURVEYED	
PLOTTED	
TEMPLATE	
NOTE BOOK	
AREAS CHECKED	
NO.	

DATE	
BY	
SURVEYED	
PLOTTED	
TEMPLATE	
NOTE BOOK	
AREAS CHECKED	
NO.	

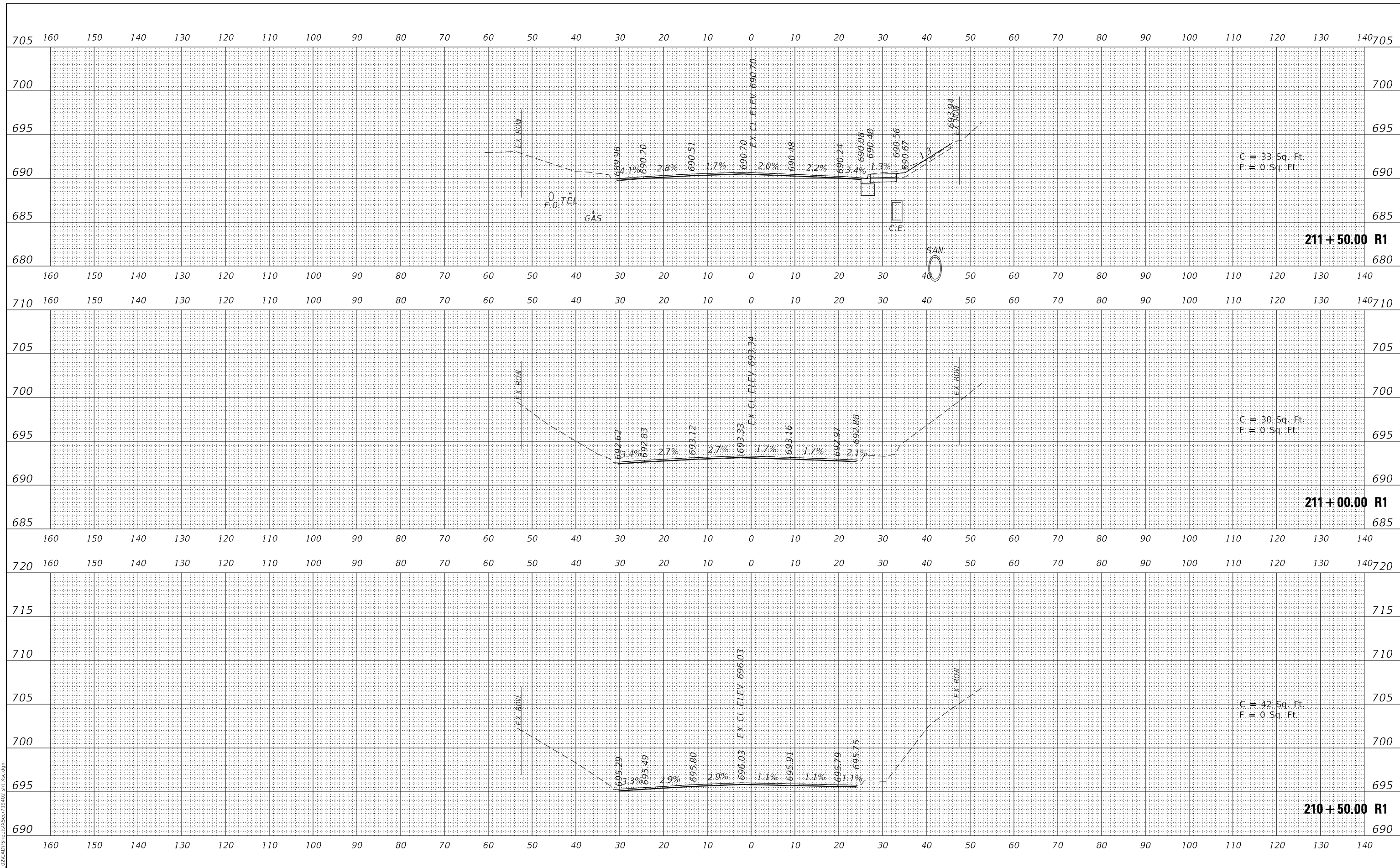

MODEL: \$P0DELIMAMES
FILE NAME: I:\14-00124\Drawings\Sheet\19102-04-01-01.dwg

KNIGHT Engineers & Architects	USER NAME = USZE706065	DESIGNED - D.M.S.	REVISED -
	PLOT SCALE = 1"=10' H : 1"=5' V	DRAWN - D.M.S.	REVISED -
	PLOT DATE = 2/8/2024	CHECKED - J.R.S.	REVISED -
		DATE - 8/12/22	REVISED -

**STATE OF ILLINOIS
DEPARTMENT OF TRANSPORTATION**

PROPOSED CROSS SECTIONS WARRENVILLE ROAD			
SCALE: 20	SHEET 2	OF 14 SHEETS	STA. 210+50.00 R1 TO STA. 211+50.00 R1

F.A. RTE.	SECTION	COUNTY	TOTAL SHEETS	SHEET NO.
1479	14-00124-04-BR	DUPAGE	208	185
CONTRACT NO. 61114				
ILLINOIS FED. AID PROJECT				

DATE	
BY	
SURVEYED	
PLOTTED	
TEMPLATE	
AREAS	
CHECKED	
NO.	
FINAL SURVEY	
NOTE BOOK	
AREAS CHECKED	
NO.	

DATE	
BY	
SURVEYED	
PLOTTED	
TEMPLATE	
AREAS	
CHECKED	
NO.	
ORIGINAL SURVEY	
NOTE BOOK	
AREAS CHECKED	
NO.	

MODEL: \$P0DELIMAMES
FILE NAME: TX194-00124-Sheets\Sheet19-02-24-25.dgn

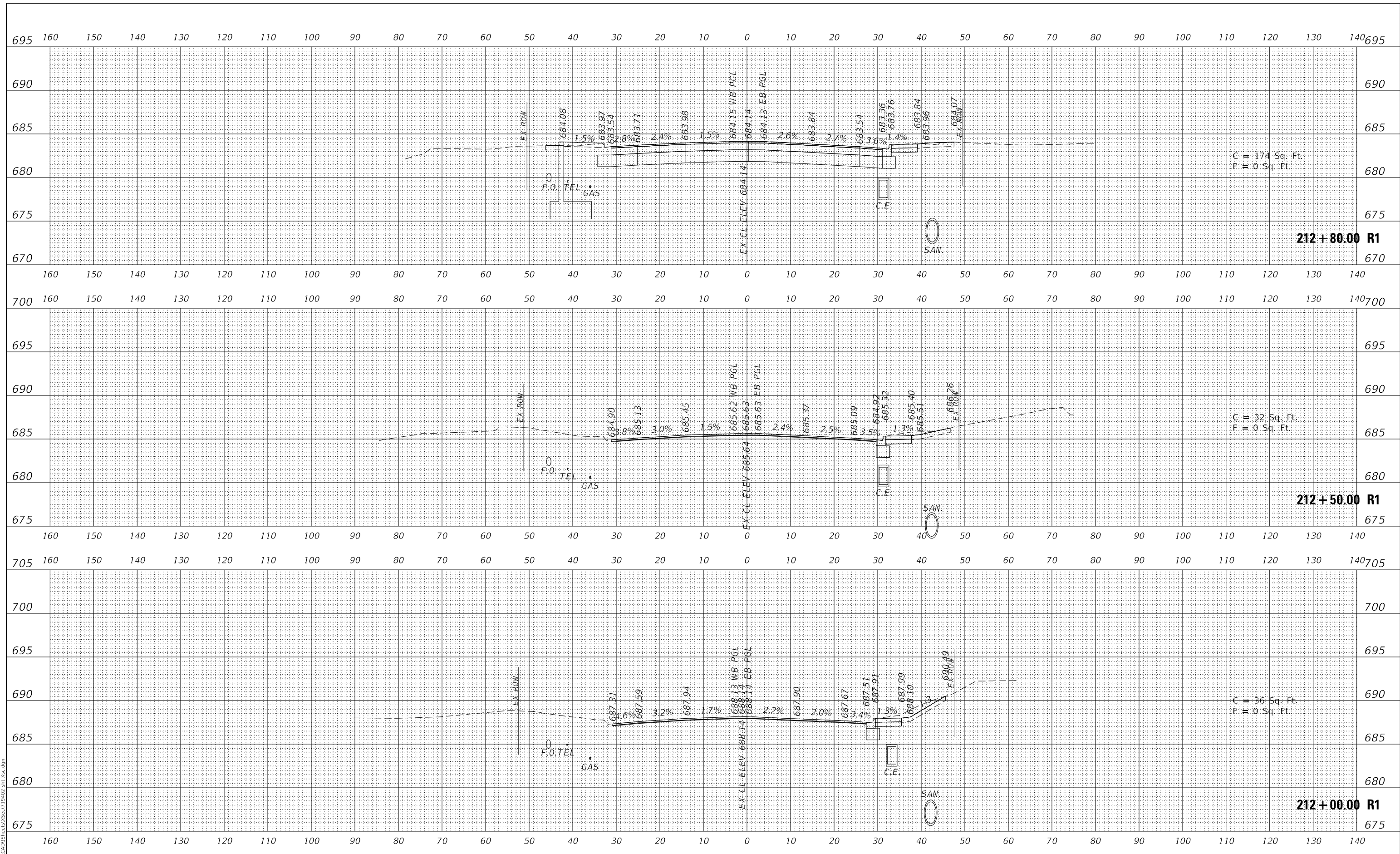

USER NAME = USZE706065	DESIGNED - D.M.S.	REVISED -
PLOT SCALE = 1"=10' H : 1"=5' V	DRAWN - D.M.S.	REVISED -
PLOT DATE = 2/8/2024	CHECKED - J.R.S.	REVISED -
	DATE - 8/12/22	REVISED -

**STATE OF ILLINOIS
DEPARTMENT OF TRANSPORTATION**

PROPOSED CROSS SECTIONS WARRENVILLE ROAD			
SCALE: 20	SHEET 3	OF 14 SHEETS	STA. 212+00.00 R1 TO STA. 212+80.00 R1

F.A. RTE.	SECTION	COUNTY	TOTAL SHEETS	SHEET NO.
1479	14-00124-04-BR	DUPAGE	208	186
CONTRACT NO. 61114				
ILLINOIS		FED. AID PROJECT		

FINAL SURVEY NO.	DATE
SURVEYED	
PLOTTED	
TEMPLATE	
AREAS	
CHECKED	

ORIGINAL SURVEY NO.	DATE
SURVEYED	
PLOTTED	
TEMPLATE	
AREAS	
CHECKED	

MODEL: \$P0DELIMAMES
FILE NAME: I:\14-00124\Drawings\Sheet\19-02-24-X-SEC.dgn

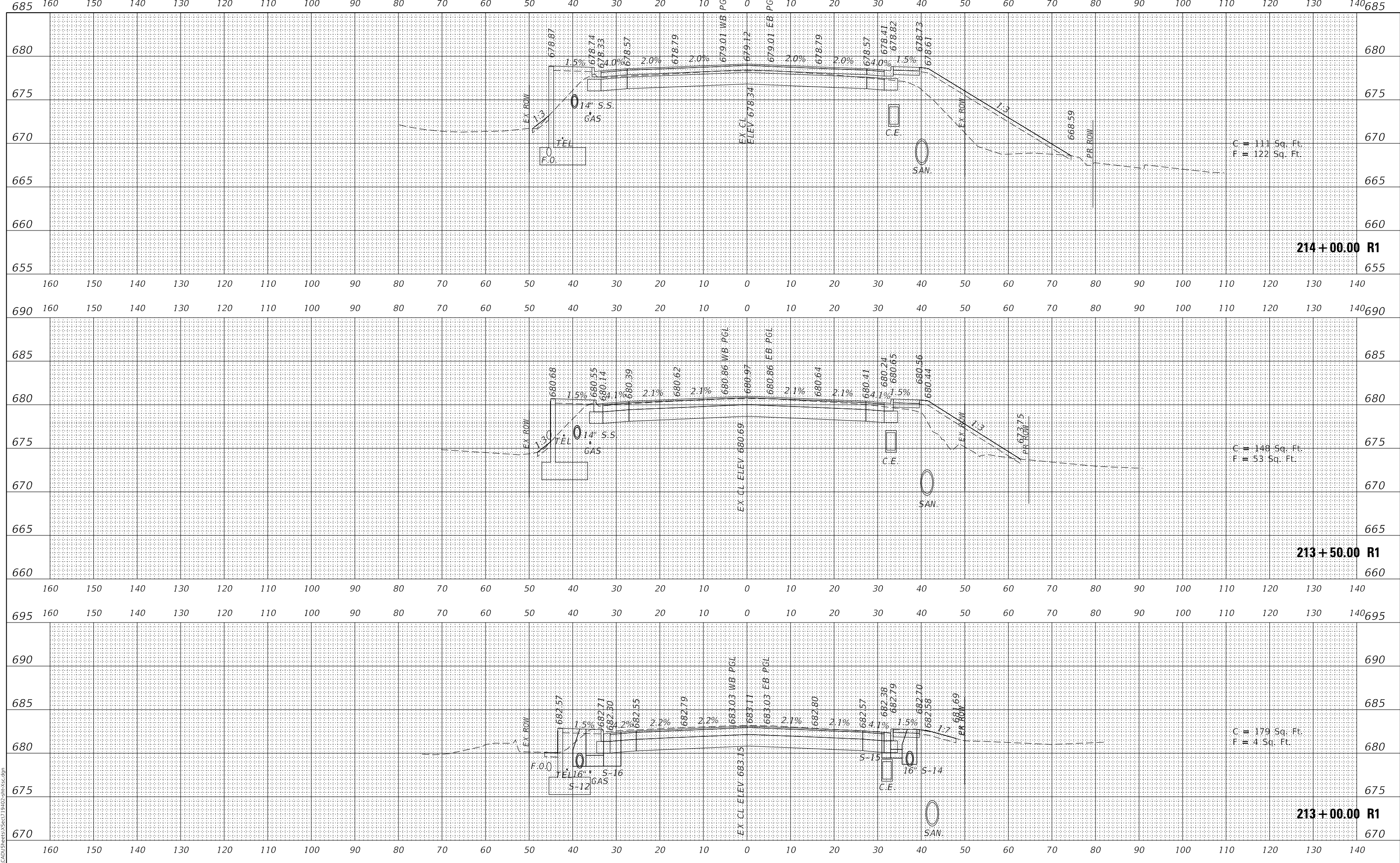

USER NAME = USZE706065
 PLOT SCALE = 1"=10' H : 1"=5' V
 PLOT DATE = 2/8/2024

DESIGNED -	D.M.S.	REVISED -	
DRAWN -	D.M.S.	REVISED -	
CHECKED -	J.R.S.	REVISED -	
DATE -	8/12/22	REVISED -	

STATE OF ILLINOIS
DEPARTMENT OF TRANSPORTATION

PROPOSED CROSS SECTIONS
WARRENVILLE ROAD

SCALE: 20 SHEET 4 OF 14 SHEETS STA. 213+00.00 R1 TO STA. 214+00.00 R1

F.A. RTE.	SECTION	COUNTY	TOTAL SHEETS	SHEET NO.
1479	14-00124-04-BR	DUPAGE	208	187
CONTRACT NO. 61114				
ILLINOIS FED. AID PROJECT				

FINAL SURVEY NO.	SURVEYED	BY	DATE
NOTE BOOK	PLOTTED		
AREAS CHECKED	TEMPLATE		
	AREAS		

ORIGINAL SURVEY NO.	SURVEYED	BY	DATE
NOTE BOOK	PLOTTED		
AREAS CHECKED	TEMPLATE		
	AREAS		

MODEL: \$MODELNAME\$
FILE NAME: I:\14-00124\Drawings\Sheet\19-02-24-XS.dwg

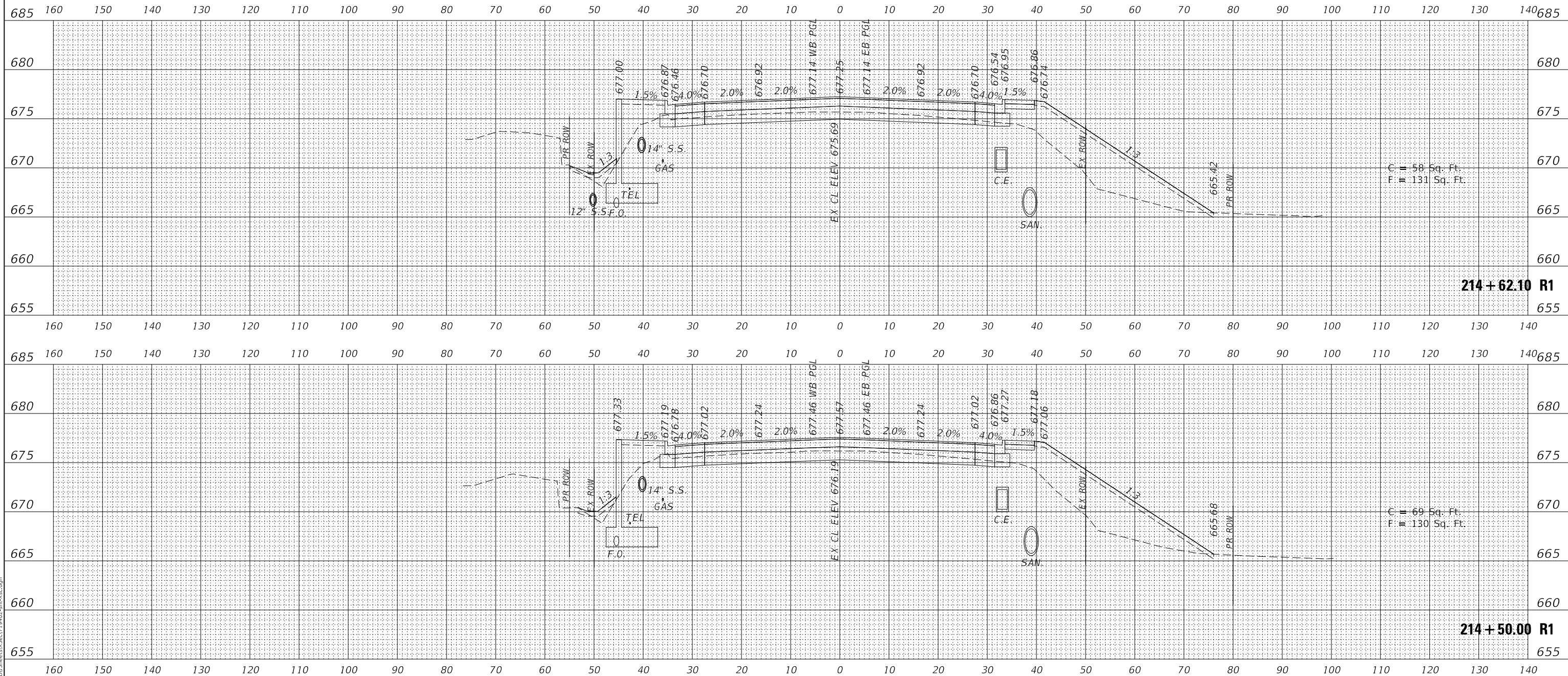

USER NAME = USZE706065
PLOT SCALE = 1"=10' H : 1"=5' V
PLOT DATE = 2/8/2024

DESIGNED - D.M.S.
DRAWN - D.M.S.
CHECKED - J.R.S.
DATE - 8/12/22

REVISED -
REVISED -
REVISED -
REVISED -

STATE OF ILLINOIS
DEPARTMENT OF TRANSPORTATION

PROPOSED CROSS SECTIONS
WARRENVILLE ROAD

SCALE: 20 SHEET 5 OF 14 SHEETS STA. 214+50.00 R1 TO STA. 214+62.10 R1

F.A. RTE.	SECTION	COUNTY	TOTAL SHEETS	SHEET NO.
1479	14-00124-04-BR	DUPAGE	208	188
CONTRACT NO. 61114				
ILLINOIS		FED. AID PROJECT		

DATE	
BY	
NO.	
FINAL SURVEY	SURVEYED
NOTE BOOK	PLOTTED
NO.	TEMPLATE
	AREAS CHECKED
	AREAS CHECKED

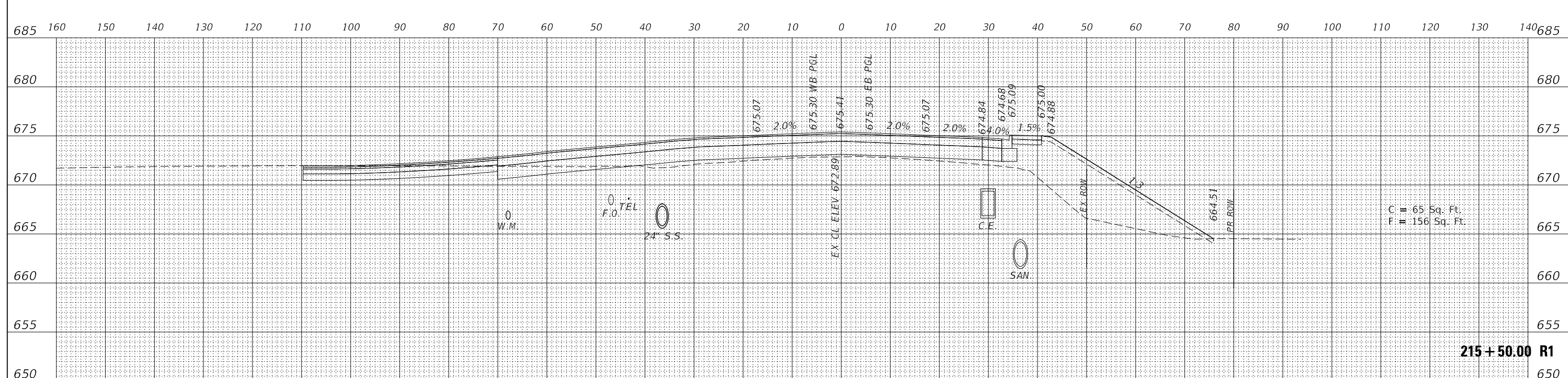

DATE	
BY	
NO.	
ORIGINAL SURVEY	SURVEYED
NOTE BOOK	PLOTTED
NO.	TEMPLATE
	AREAS CHECKED
	AREAS CHECKED

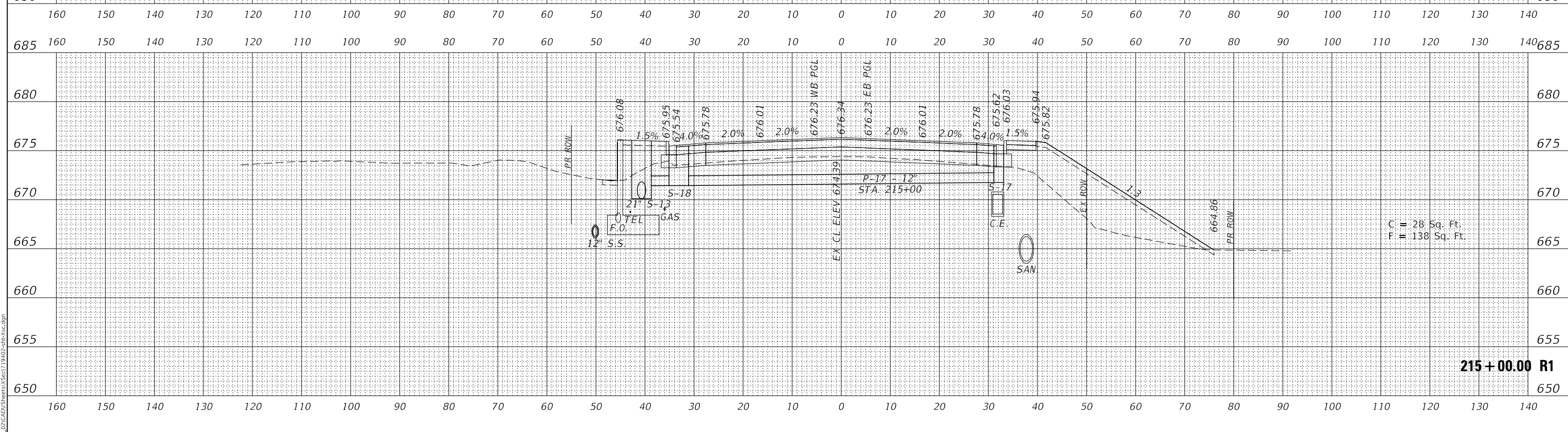

MODEL: \$MODELNAME\$
FILE NAME: TX194-00-CADD\Drawings\Sheet\19402-sh-r1.dwg



USER NAME = USZE706065
PLOT SCALE = 1"=10' H : 1"=5' V
PLOT DATE = 2/8/2024

DESIGNED - D.M.S.
DRAWN - D.M.S.
CHECKED - J.R.S.
DATE - 8/12/22

REVISED -
REVISED -
REVISED -
REVISED -

STATE OF ILLINOIS
DEPARTMENT OF TRANSPORTATION

PROPOSED CROSS SECTIONS
WARRENVILLE ROAD

SCALE: 20 SHEET 6 OF 14 SHEETS STA. 215+00.00 R1 TO STA. 215+50.00 R1

F.A. RTE.	SECTION	COUNTY	TOTAL SHEETS	SHEET NO.
1479	14-00124-04-BR	DUPAGE	208	189
CONTRACT NO. 61114				
ILLINOIS FED. AID PROJECT				

DATE	
BY	
SURVEYED	
PLOTTED	
TEMPLATE	
NOTE BOOK	
AREAS	
CHECKED	
NO.	

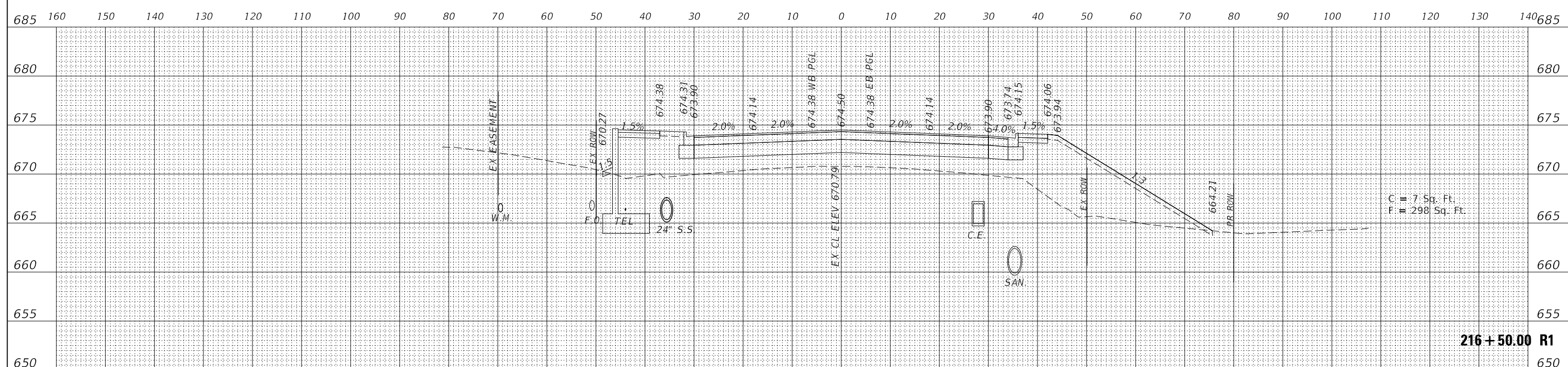

216+50.00 R1

C = 7 Sq. Ft.
F = 298 Sq. Ft.

DATE	
BY	
SURVEYED	
PLOTTED	
TEMPLATE	
NOTE BOOK	
AREAS	
CHECKED	
NO.	

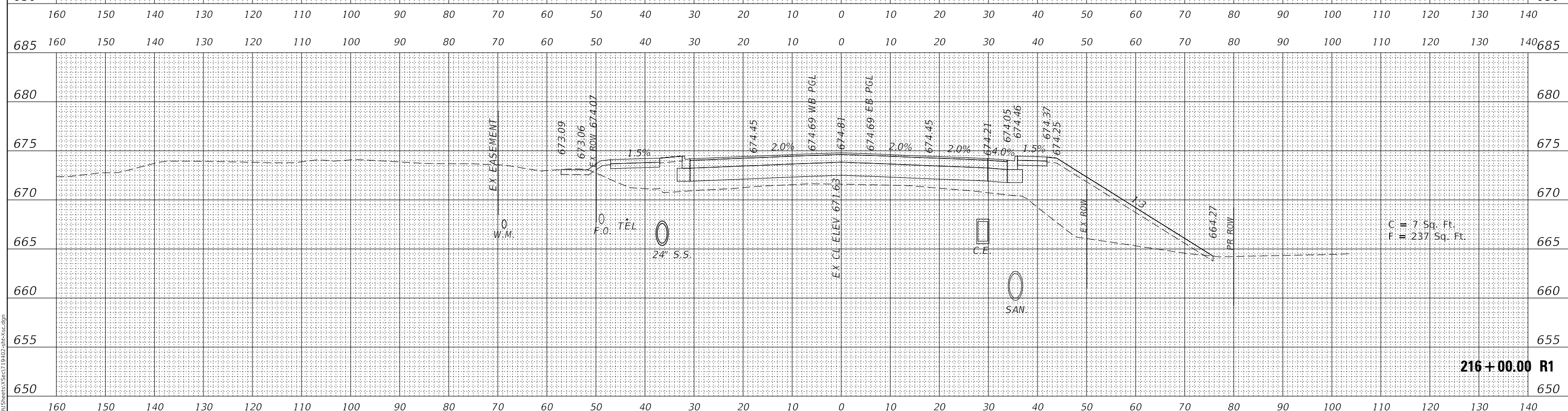

216+00.00 R1

C = 7 Sq. Ft.
F = 237 Sq. Ft.

MODEL: \$MODELNAME\$
FILE NAME: TX194-00-00-00-Sheets\5631719-02-sh-xsec.dgn



USER NAME = USZE706065	DESIGNED - D.M.S.	REVISED -
	DRAWN - D.M.S.	REVISED -
PLOT SCALE = 1"=10' H : 1"=5' V	CHECKED - J.R.S.	REVISED -
PLOT DATE = 2/8/2024	DATE - 8/12/22	REVISED -

STATE OF ILLINOIS
DEPARTMENT OF TRANSPORTATION

PROPOSED CROSS SECTIONS
WARRENVILLE ROAD

SCALE: 20 SHEET 7 OF 14 SHEETS STA. 216+00.00 R1 TO STA. 216+50.00 R1

F.A. RTE.	SECTION	COUNTY	TOTAL SHEETS	SHEET NO.
1479	14-00124-04-BR	DUPAGE	208	190
CONTRACT NO. 61114				

ILLINOIS FED. AID PROJECT

DATE	
BY	
NO.	
FINAL SURVEY	SURVEYED
NOTE BOOK	PLOTTED
NO.	TEMPLATE
	AREAS
	CHECKED

DATE	
BY	
NO.	
ORIGINAL SURVEY	SURVEYED
NOTE BOOK	PLOTTED
NO.	TEMPLATE
	AREAS
	CHECKED

MODEL: \$P0DEL\$
FILE NAME: I:\14-00124\Drawings\Sheet\19102-217+00-217+50.dwg

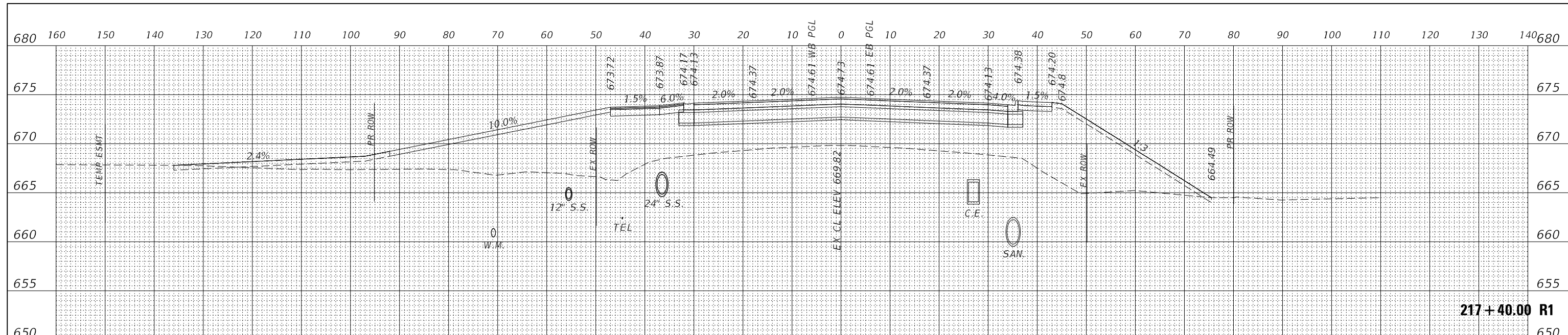

217+40.00 R1

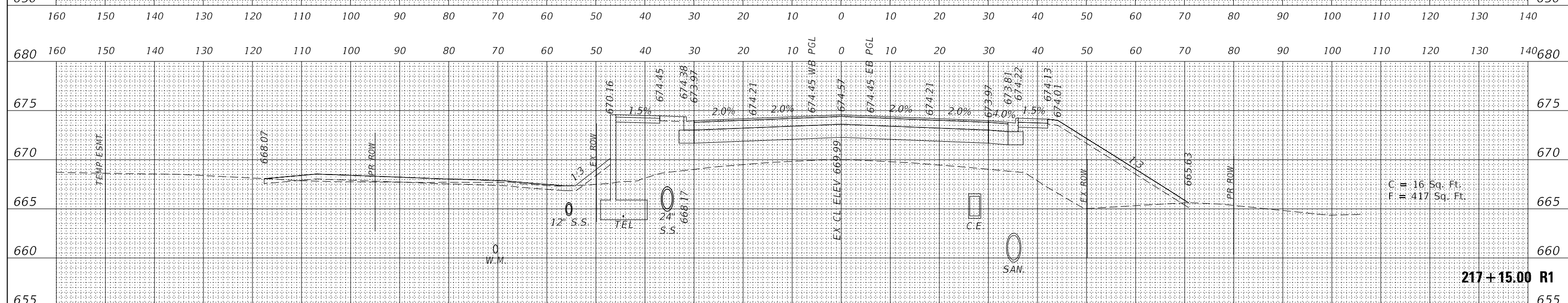

217+15.00 R1

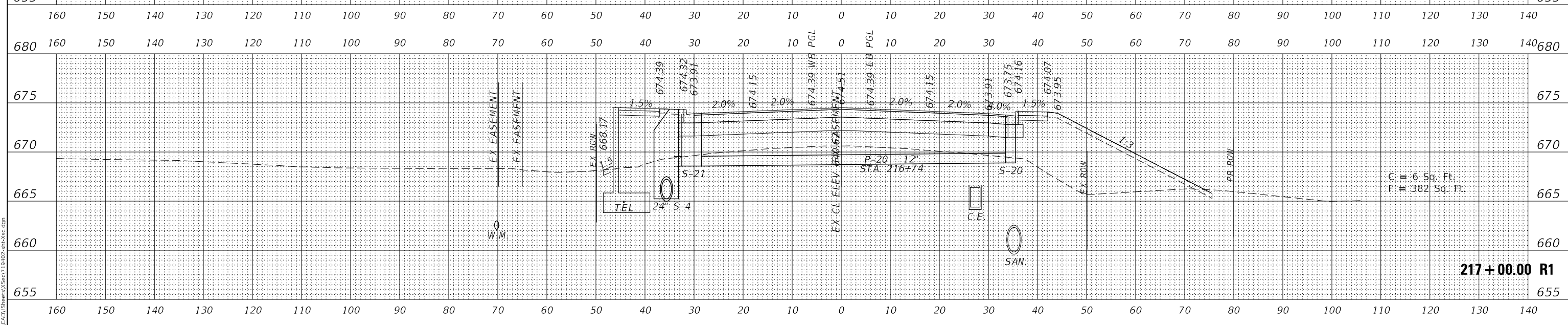

217+00.00 R1



USER NAME = USZE706065
PLOT SCALE = 1"=10' H : 1"=5' V
PLOT DATE = 2/8/2024

DESIGNED - D.M.S.
DRAWN - D.M.S.
CHECKED - J.R.S.
DATE - 8/12/22

REVISED -
REVISED -
REVISED -
REVISED -

STATE OF ILLINOIS
DEPARTMENT OF TRANSPORTATION

SCALE: 20
SHEET 8 OF 14 SHEETS
STA. 217+00.00 R1 TO STA. 217+50.00 R1

PROPOSED CROSS SECTIONS
WARRENVILLE ROAD

F.A. RTE.	SECTION	COUNTY	TOTAL SHEETS	SHEET NO.
1479	14-00124-04-BR	DUPAGE	208	191
CONTRACT NO. 61114				
ILLINOIS FED. AID PROJECT				

FINAL SURVEY	SURVEYED
NOTE BOOK	PLOTTED
NO.	TEMPLATE
	AREAS CHECKED
	AREAS CHECKED

ORIGINAL SURVEY	SURVEYED
NOTE BOOK	PLOTTED
NO.	TEMPLATE
	AREAS CHECKED
	AREAS CHECKED

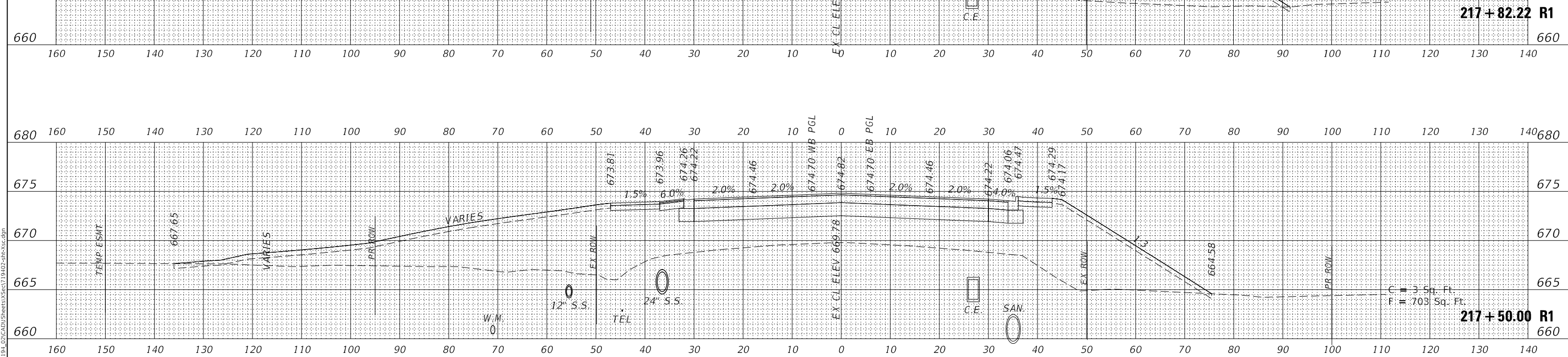
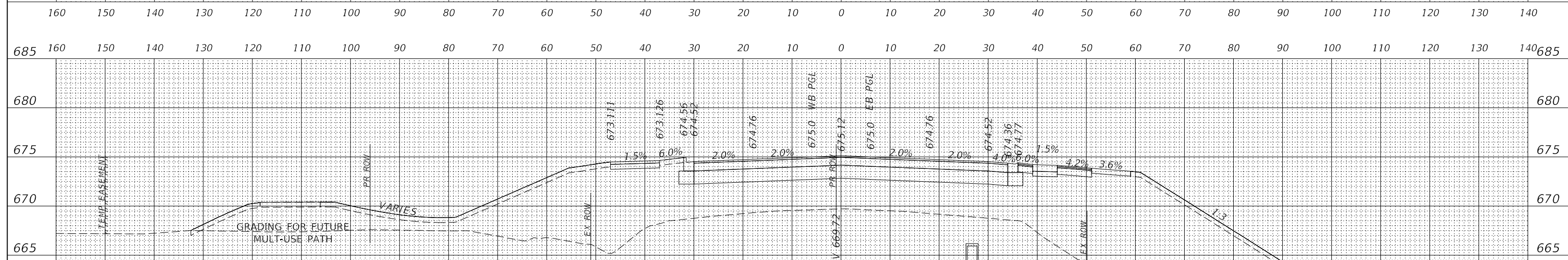
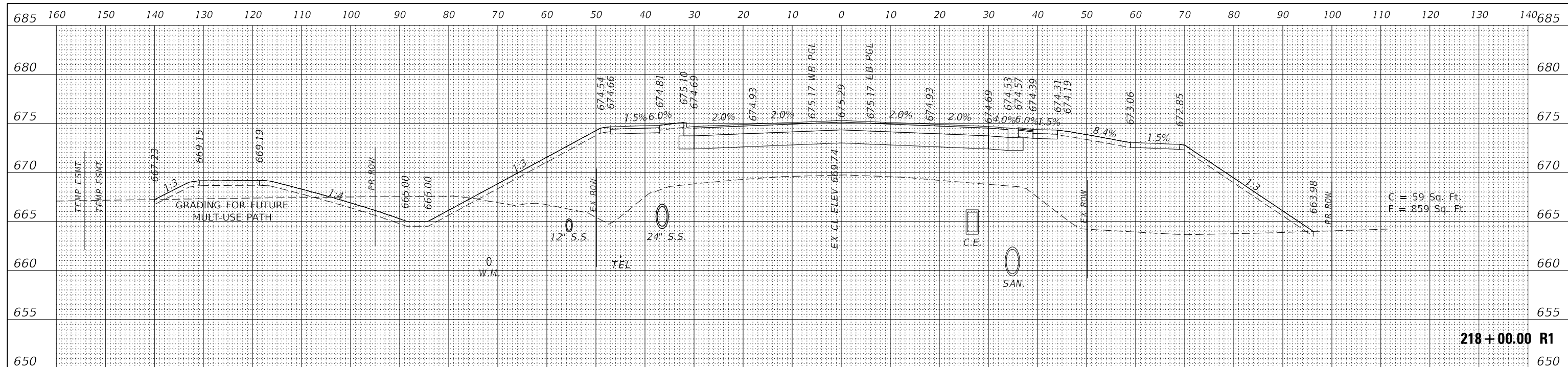

MODEL: \$P01\$MINI\$MMS\$
 FILE NAME: I:\14\DCAD\Drawings\Sheets\217\19102-sha-XS.dwg



USER NAME = USZE706065	DESIGNED - D.M.S.	REVISED -
PLOT SCALE = 1"=10' H: 1"=5' V	DRAWN - D.M.S.	REVISED -
PLOT DATE = 2/8/2024	CHECKED - J.R.S.	REVISED -
	DATE - 8/12/22	REVISED -

**STATE OF ILLINOIS
DEPARTMENT OF TRANSPORTATION**

SCALE: 20	SHEET 9	OF 14 SHEETS	STA. 218+00.00 R1 TO STA. 218+50.00 R1
-----------	---------	--------------	--

**PROPOSED CROSS SECTIONS
WARRENVILLE ROAD**

F.A. RTE.	SECTION	COUNTY	TOTAL SHEETS	SHEET NO.
1479	14-00124-04-BR	DUPAGE	208	192
				CONTRACT NO. 61114
		ILLINOIS	FED. AID PROJECT	

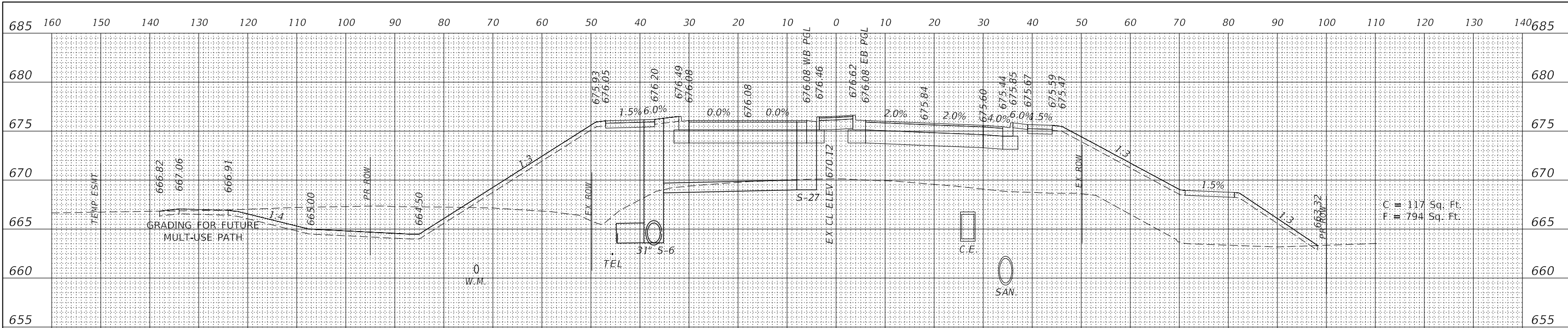

685	160	150	140	130	120	110	100	90	80	70	60	50	40	30	20	10	0	10	20	30	40	50	60	70	80	90	100	110	120	130	140	685
650	160	150	140	130	120	110	100	90	80	70	60	50	40	30	20	10	0	10	20	30	40	50	60	70	80	90	100	110	120	130	140	650

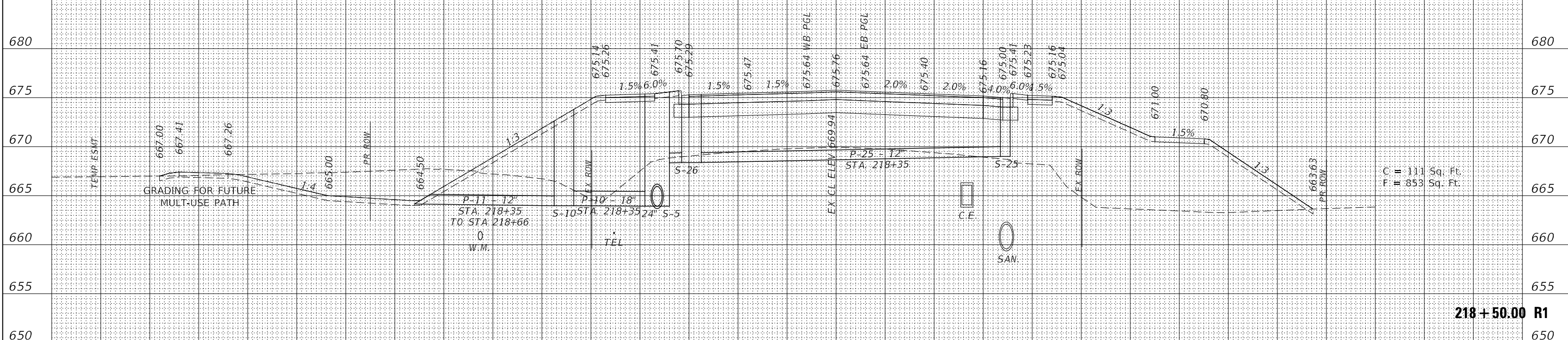

685	160	150	140	130	120	110	100	90	80	70	60	50	40	30	20	10	0	10	20	30	40	50	60	70	80	90	100	110	120	130	140	685
650	160	150	140	130	120	110	100	90	80	70	60	50	40	30	20	10	0	10	20	30	40	50	60	70	80	90	100	110	120	130	140	650



USER NAME = USZE706065	DESIGNED - D.M.S.	REVISED -
	DRAWN - D.M.S.	REVISED -
PLOT SCALE = 1"=10' H : 1"=5' V	CHECKED - J.R.S.	REVISED -
PLOT DATE = 2/8/2024	DATE - 8/12/22	REVISED -

STATE OF ILLINOIS
DEPARTMENT OF TRANSPORTATION

PROPOSED CROSS SECTIONS
WARRENVILLE ROAD

SCALE: SHEET 10 OF 14 SHEETS STA. 219+00.00 R1 TO STA. 219+50.00 R1

F.A. RTE.	SECTION	COUNTY	TOTAL SHEETS	SHEET NO.
1479	14-00124-04-BR	DUPAGE	208	193
CONTRACT NO. 61114				
ILLINOIS FED. AID PROJECT				

MODEL: \$MODELNAME.S
FILE NAME: T:\14-00124\Drawings\Sheet\19102-ash-r1.dgn

BY	DATE
SURVEYED	
PLOTTED	
TEMPLATE	
AREAS	
CHECKED	

BY	DATE
ORIGINAL SURVEY	
NOTE BOOK	
NO.	
CHECKED	

FINAL SURVEY	SURVEYED	BY	DATE
NOTE BOOK	PLOTTED		
NO.	TEMPLATE		
	AREAS CHECKED		

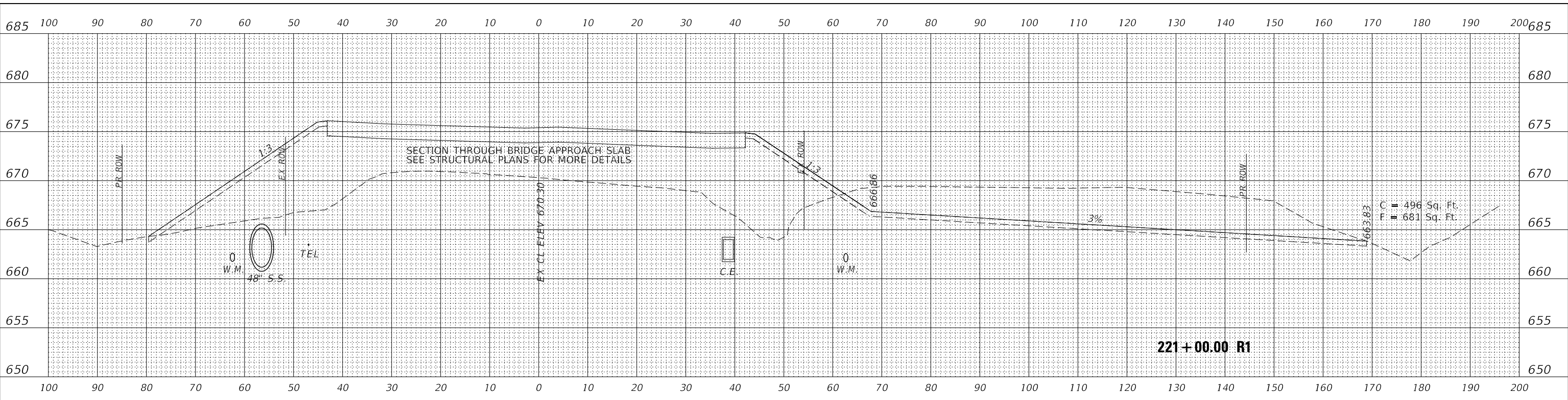

ORIGINAL SURVEY	SURVEYED	BY	DATE
NOTE BOOK	PLOTTED		
NO.	TEMPLATE		
	AREAS CHECKED		

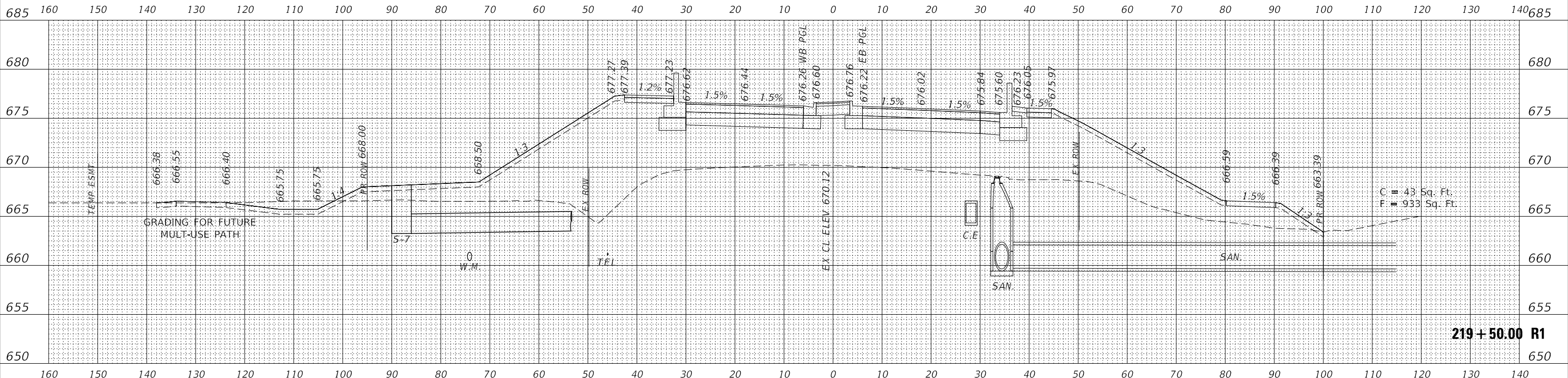

MODEL: \$P0DEL\$NAME\$
FILE NAME: TX1914-00-CADD\Sheets\Sheet19-02-ah-25c.dgn



USER NAME = USZE706065	DESIGNED - D.M.S.	REVISED -
PLOT SCALE = 1"=10' H : 1"=5' V	DRAWN - D.M.S.	REVISED -
PLOT DATE = 2/8/2024	CHECKED - J.R.S.	REVISED -
	DATE - 8/12/22	REVISED -

STATE OF ILLINOIS
DEPARTMENT OF TRANSPORTATION

PROPOSED CROSS SECTIONS		
WARRENVILLE ROAD		
SCALE:	SHEET 11 OF 14 SHEETS	STA. 221+00.00 R1 TO STA. 221+50.00 R1

F.A. RTE.	SECTION	COUNTY	TOTAL SHEETS	SHEET NO.
1479	14-00124-04-BR	DUPAGE	208	194
CONTRACT NO. 61114				
ILLINOIS FED. AID PROJECT				

FINAL SURVEY	SURVEYED	BY	DATE
NOTE BOOK	PLOTTED		
NO.	TEMPLATE		
	AREAS		
	CHECKED		

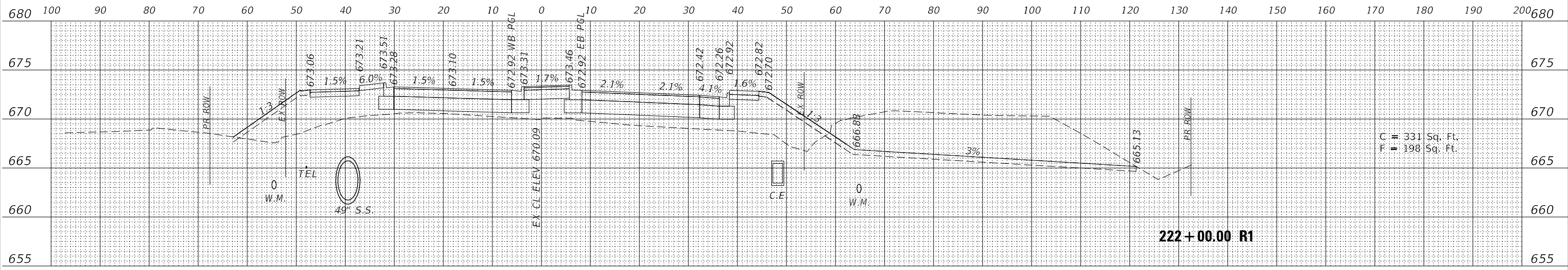

ORIGINAL SURVEY	SURVEYED	BY	DATE
NOTE BOOK	PLOTTED		
NO.	TEMPLATE		
	AREAS		
	CHECKED		

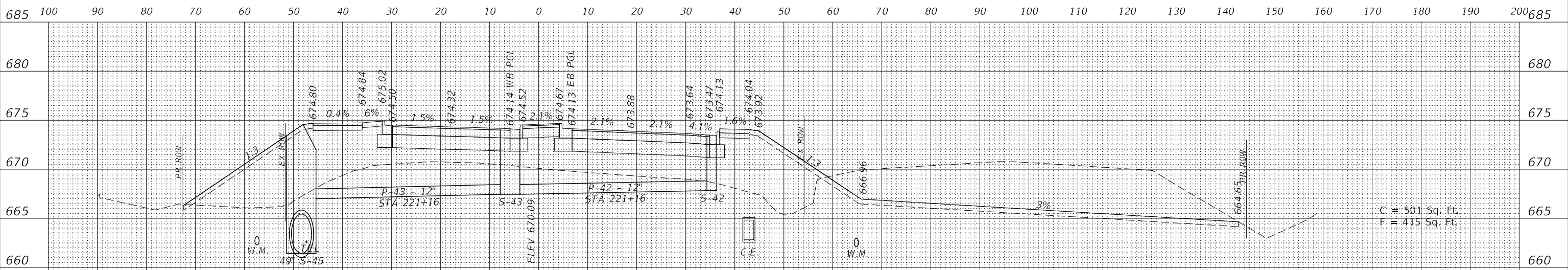

MODEL: \$MODELNAME\$
FILE NAME: I:\1914\CD\Drawings\Sheets\Sec1719102-sh1-xsec.dgn



USER NAME = USZE706065	DESIGNED - D.M.S.	REVISED -
PLOT SCALE = 1"=10' H : 1"=5' V	DRAWN - D.M.S.	REVISED -
PLOT DATE = 2/8/2024	CHECKED - J.R.S.	REVISED -
	DATE - 8/12/22	REVISED -

STATE OF ILLINOIS
DEPARTMENT OF TRANSPORTATION

PROPOSED CROSS SECTIONS
WARRENVILLE ROAD

SCALE: SHEET 12 OF 14 SHEETS STA. 222+00.00 R1 TO STA. 223+00.00 R1

F.A. RTE.	SECTION	COUNTY	TOTAL SHEETS	SHEET NO.
1479	14-00124-04-BR	DUPAGE	208	195
CONTRACT NO. 61114				
ILLINOIS		FED. AID PROJECT		

DATE	
BY	
FINAL SURVEY	SURVEYED
NOTE BOOK	PLOTTED
NO.	TEMPLATE
	AREAS CHECKED

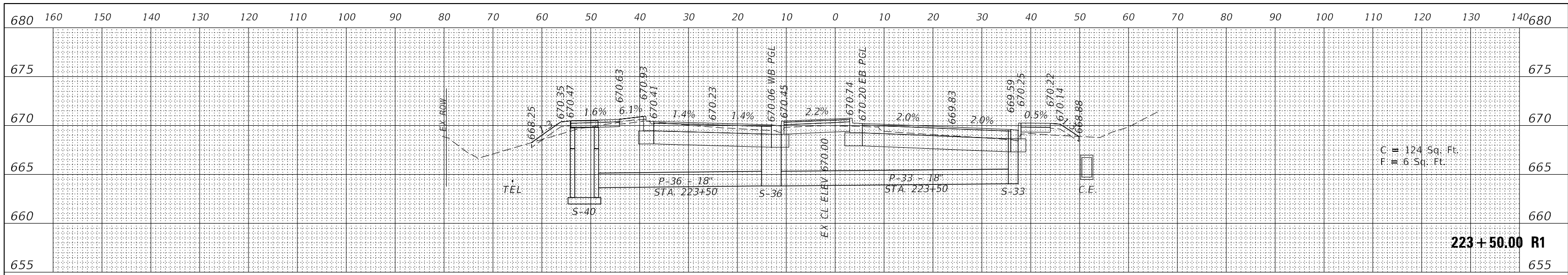

223+50.00 R1

DATE	
BY	
ORIGINAL SURVEY	SURVEYED
NOTE BOOK	PLOTTED
NO.	TEMPLATE
	AREAS CHECKED

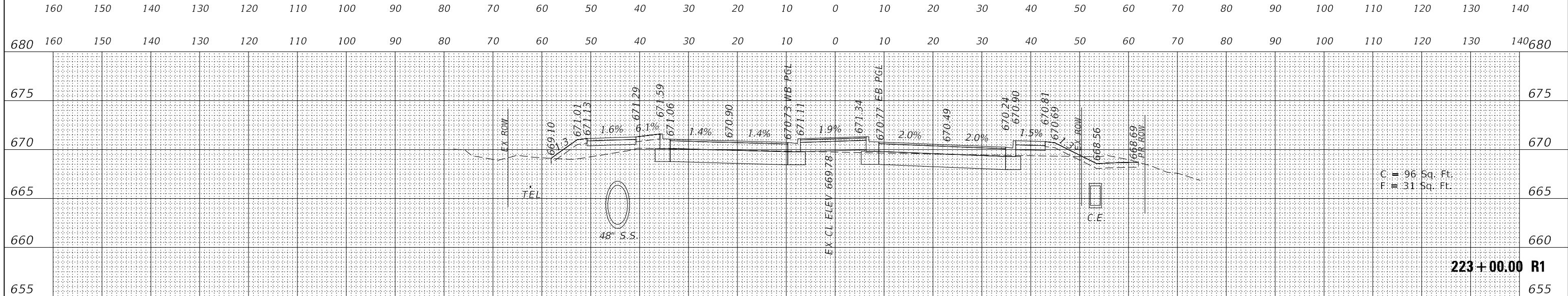

223+00.00 R1

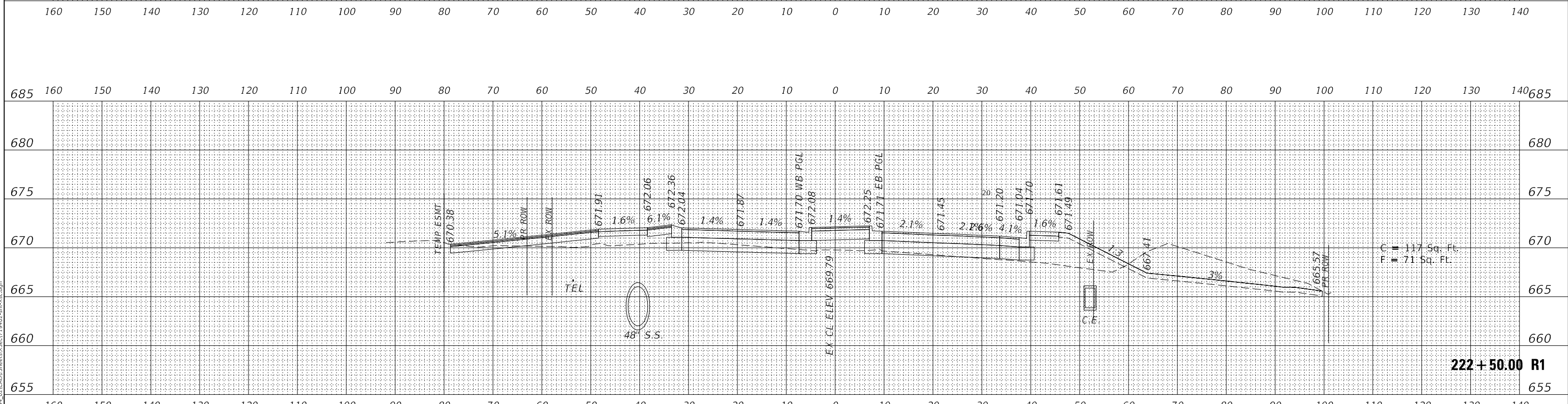

222+50.00 R1

MODEL: \$P0DELNAME\$
FILE NAME: I:\19\20\CADD\Sheets\K5631719102-210-XE.dgn



USER NAME =	USZE706065
PLOT SCALE =	1"=10' H : 1"=5' V
PLOT DATE =	2/8/2024

DESIGNED -	D.M.S.
DRAWN -	D.M.S.
CHECKED -	J.R.S.
DATE -	8/12/22

REVISED -	
REVISED -	
REVISED -	
REVISED -	

STATE OF ILLINOIS
DEPARTMENT OF TRANSPORTATION

PROPOSED CROSS SECTIONS
WARRENVILLE ROAD

SCALE: SHEET 13 OF 14 SHEETS STA. 223+50.00 R1 TO STA. 224+50.00 R1

F.A. RTE.	SECTION	COUNTY	TOTAL SHEETS	SHEET NO.
1479	14-00124-04-BR	DUPAGE	208	196
CONTRACT NO. 61114				
ILLINOIS		FED. AID PROJECT		

DATE	
BY	
SURVEYED	
PLOTTED	
TEMPLATE	
AREAS	
CHECKED	
NO.	

DATE	
BY	
SURVEYED	
PLOTTED	
TEMPLATE	
AREAS	
CHECKED	
NO.	

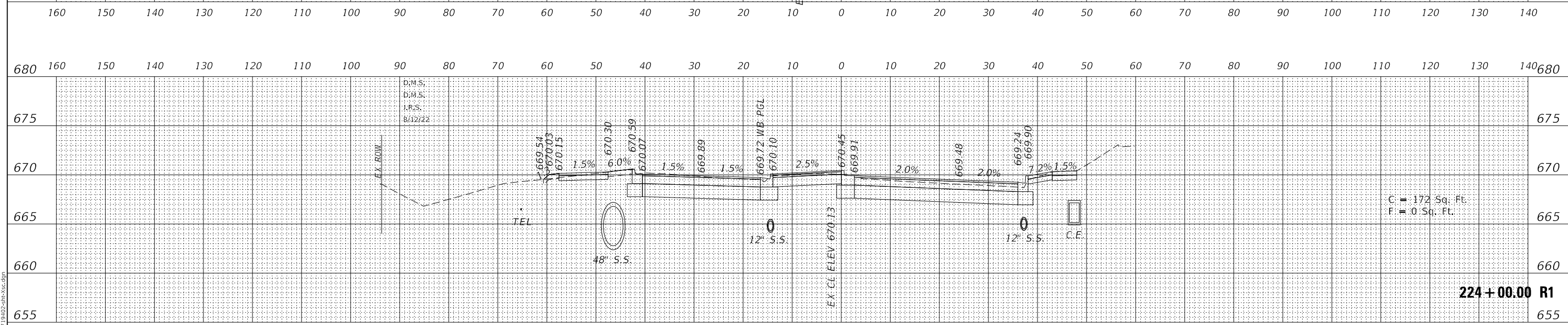
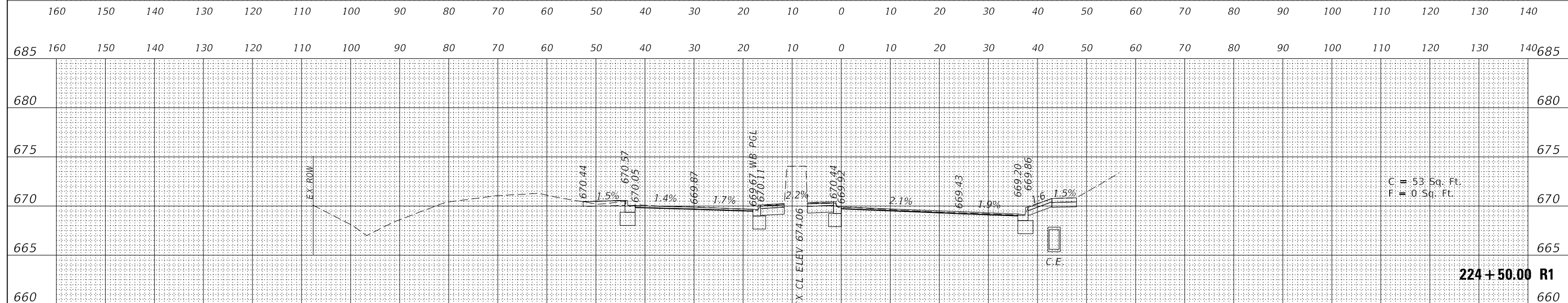
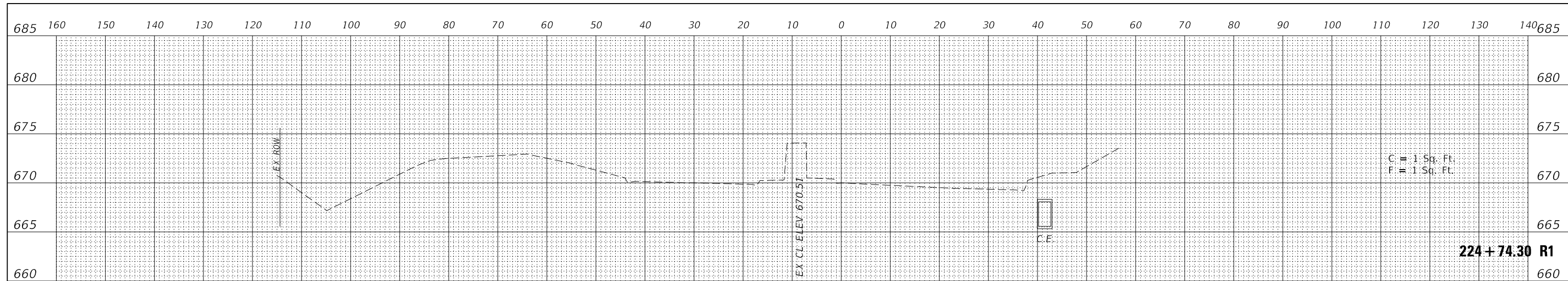

MODEL: \$PLOT\$NAME\$.S
 FILE NAME: I:\14-00\CAD\Drawings\Sheets\5651719-02-24-24.dwg



USER NAME = USZE706065	DESIGNED - D.M.S.	REVISED -
	DRAWN - D.M.S.	REVISED -
PLOT SCALE = 1"=10' H : 1"=5' V	CHECKED - J.R.S.	REVISED -
PLOT DATE = 2/8/2024	DATE - 8/12/22	REVISED -

STATE OF ILLINOIS
DEPARTMENT OF TRANSPORTATION

SCALE: 20	SHEET 14	OF 14 SHEETS	STA. 224+74.30 R1 TO STA. 224+74.30 R1
-----------	----------	--------------	--

PROPOSED CROSS SECTIONS
WARRENVILLE ROAD

F.A. RTE.	SECTION	COUNTY	TOTAL SHEETS	SHEET NO.
1479	14-00124-04-BR	DUPAGE	208	197
CONTRACT NO. 61114				
ILLINOIS		FED. AID PROJECT		

FINAL SURVEY NO.	SURVEYED	BY	DATE
NOTE BOOK	PLOTTED		
NO.	TEMPLATE		
	AREAS CHECKED		

ORIGINAL SURVEY NO.	SURVEYED	BY	DATE
NOTE BOOK	PLOTTED		
NO.	TEMPLATE		
	AREAS CHECKED		

MODEL: \$MODELNAME\$
FILE NAME: I:\14-00\CAD\Drawings\Sheets\61114\02-Sub-X-2.dgn

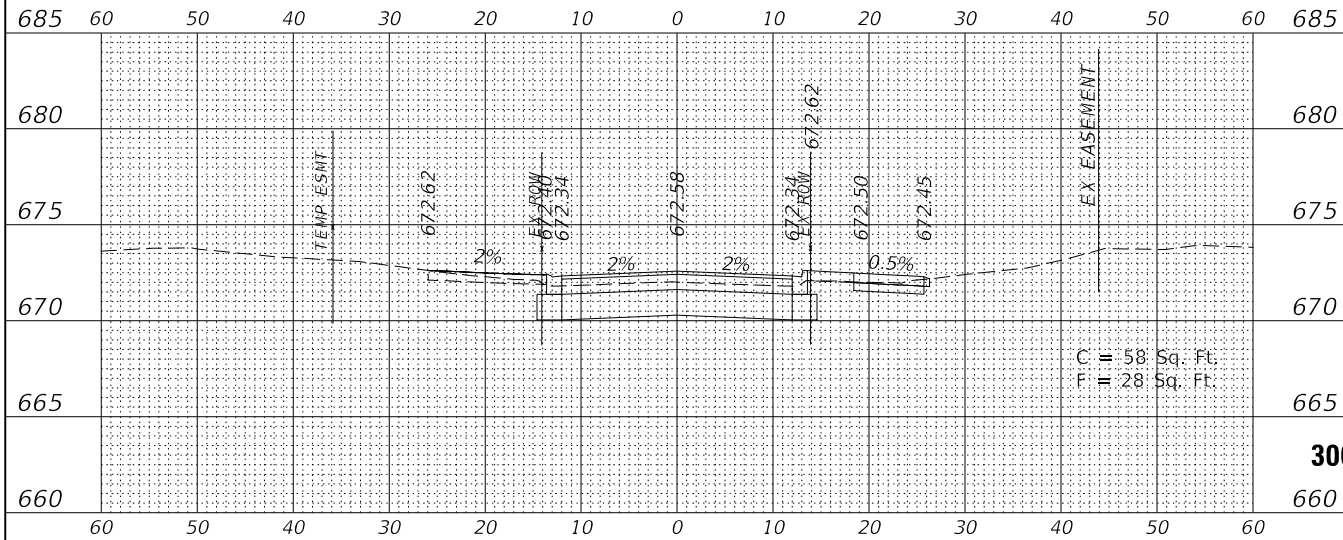

300+80.00 R1

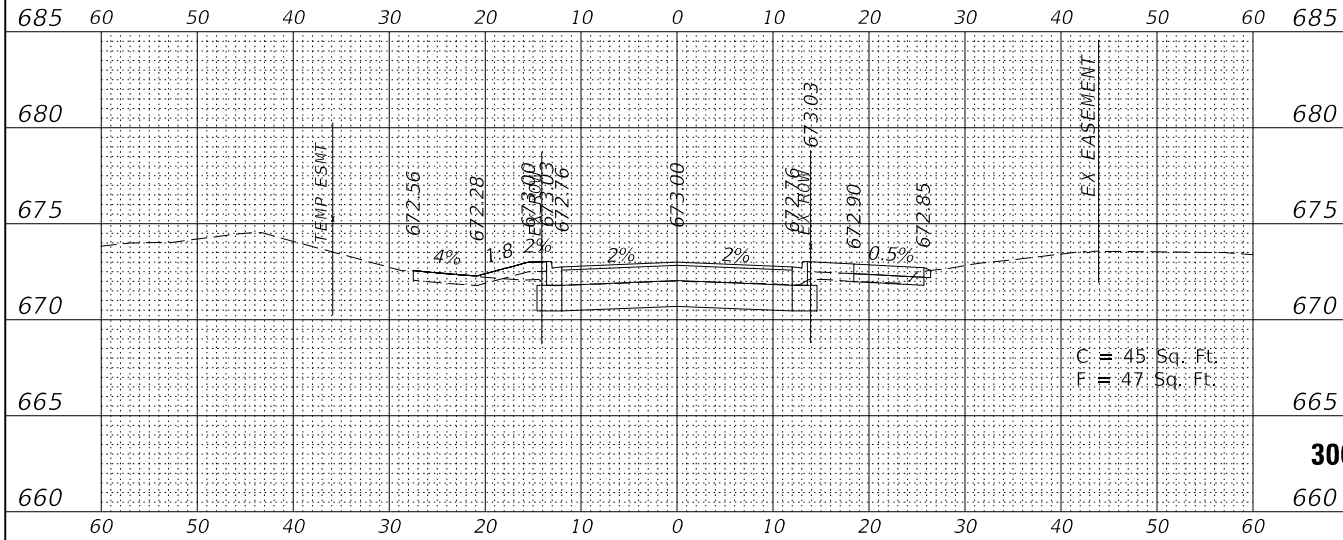

300+70.00 R1

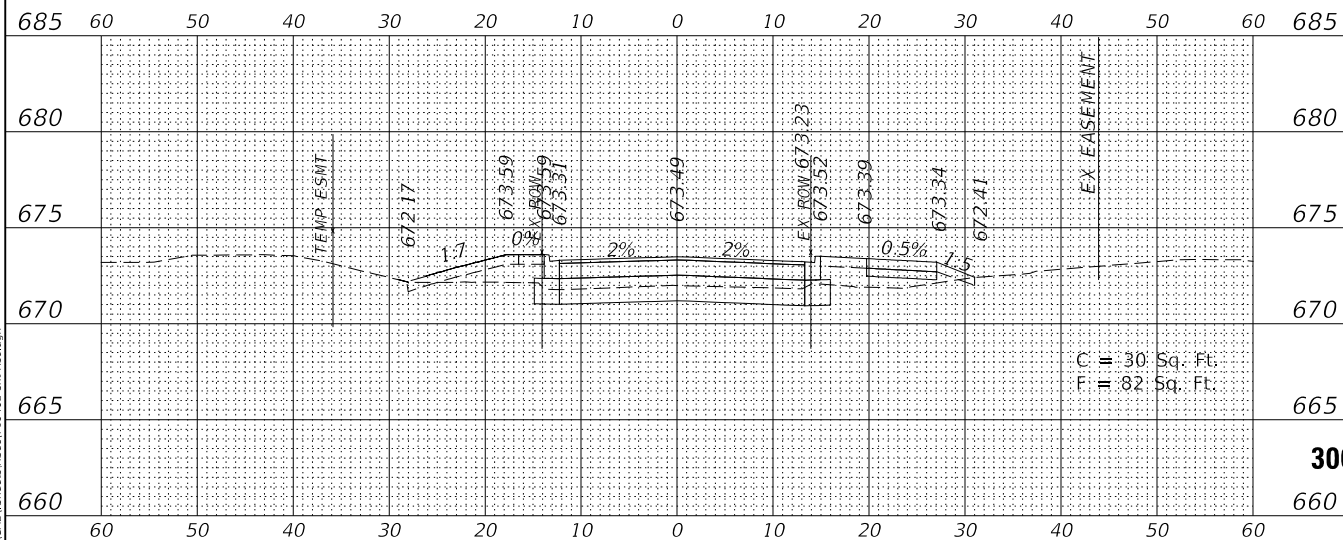

300+60.00 R1



USER NAME = USZE706065	DESIGNED - D.M.S.	REVISED -
PLOT SCALE = 1"=10' H : 1"=5' V	DRAWN - D.M.S.	REVISED -
PLOT DATE = 2/8/2024	CHECKED - J.R.S.	REVISED -
	DATE - 8/12/22	REVISED -

**STATE OF ILLINOIS
DEPARTMENT OF TRANSPORTATION**

**PROPOSED CROSS SECTIONS
WHITE BIRCH DRIVE**

SCALE: 20 SHEET 1 OF 2 SHEETS STA. 300+60.00 R1 TO STA. 301+00.00 R1

F.A. RTE.	SECTION	COUNTY	TOTAL SHEETS	SHEET NO.
1479	14-00124-04-BR	DUPAGE	208	198
CONTRACT NO. 61114				
ILLINOIS FED. AID PROJECT				

FINAL SURVEY NO.	SURVEYED	DATE
NOTE BOOK	PLOTTED	BY
NO.	TEMPLATE	
	AREAS CHECKED	

ORIGINAL SURVEY NO.	SURVEYED	DATE
NOTE BOOK	PLOTTED	BY
NO.	TEMPLATE	
	AREAS CHECKED	

MODEL: \$MODELNAME\$
FILE NAME: I:\14-00124\Drawings\Sheets\61114-19-102-Sub-X-2.dwg

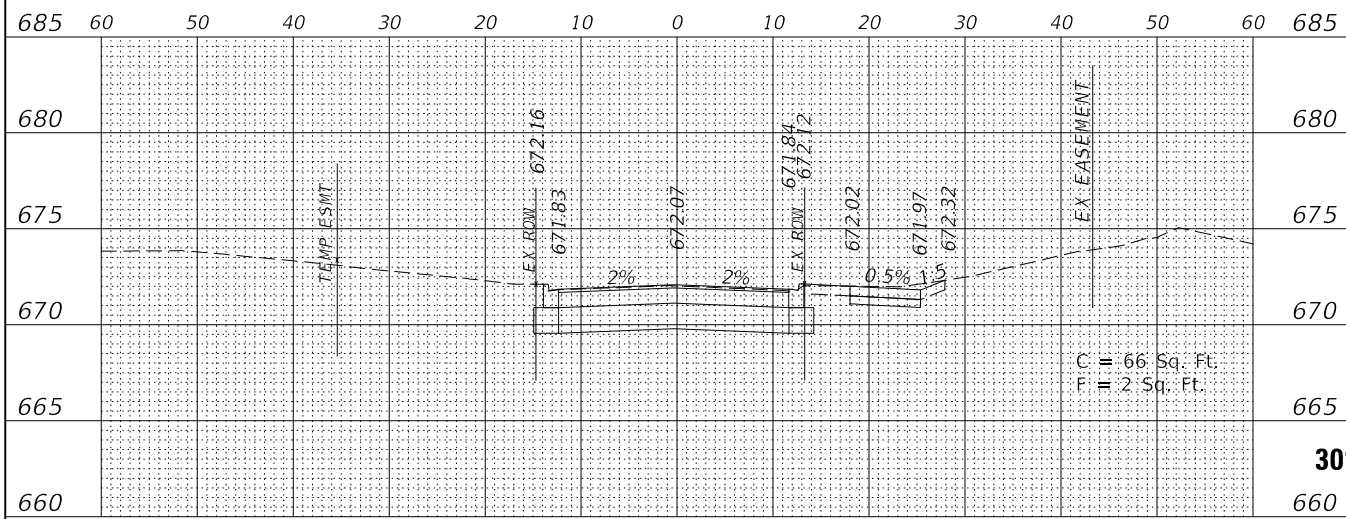

301+10.00 R1

301+20.00 R1

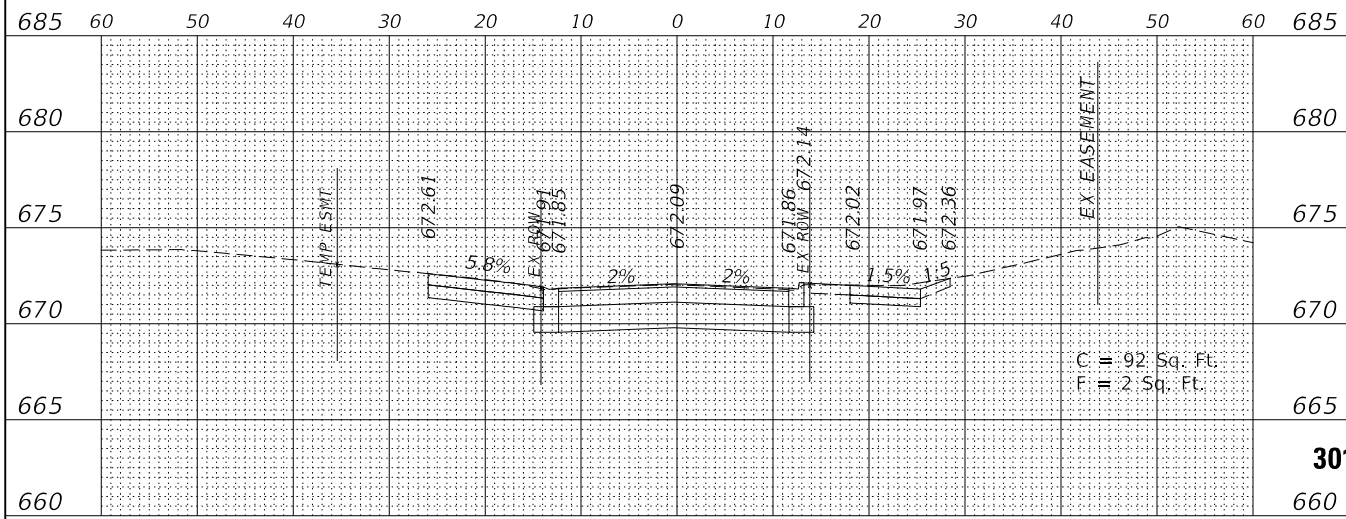
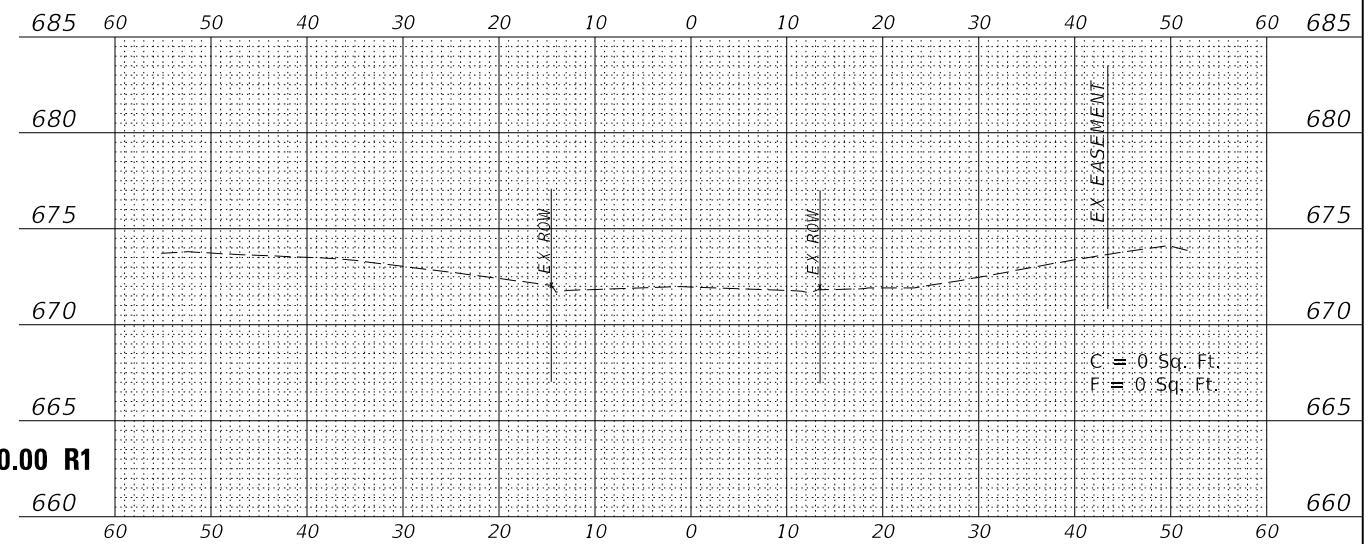

301+00.00 R1

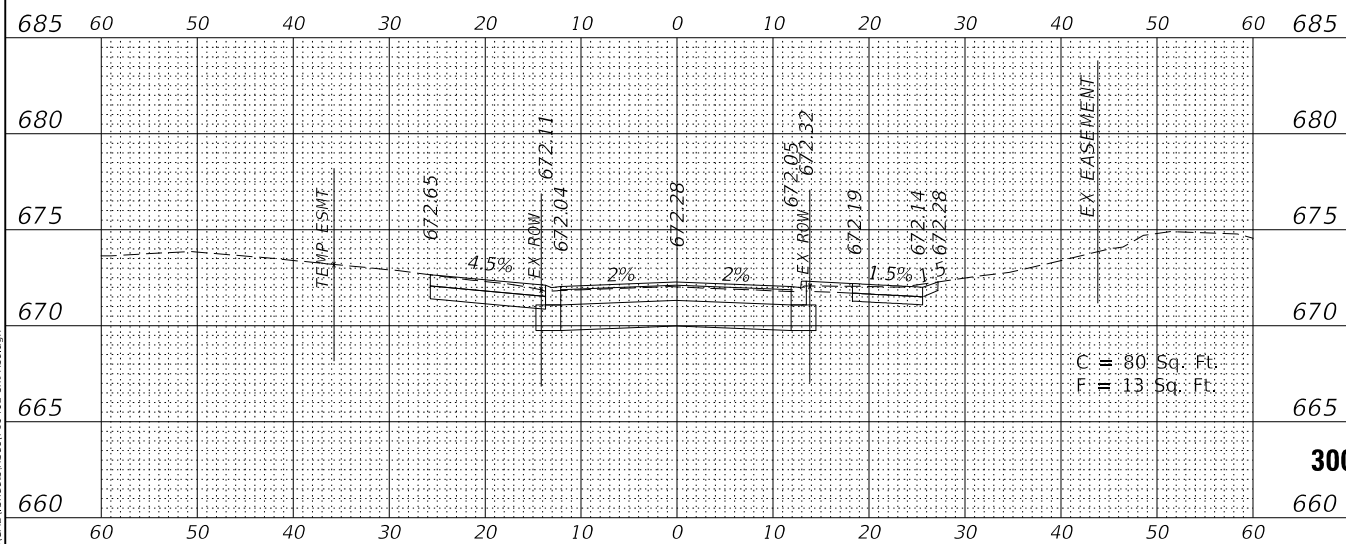

300+90.00 R1



USER NAME = USZE706065	DESIGNED - D.M.S.	REVISED -
PLOT SCALE = 1"=10' H : 1"=5' V	DRAWN - D.M.S.	REVISED -
PLOT DATE = 2/8/2024	CHECKED - J.R.S.	REVISED -
	DATE - 8/12/22	REVISED -

**STATE OF ILLINOIS
DEPARTMENT OF TRANSPORTATION**

**PROPOSED CROSS SECTIONS
WHITE BIRCH DRIVE**

SCALE: 20 SHEET 2 OF 2 SHEETS STA. 301+10.00 R1 TO STA. 301+20.00 R1

F.A. RTE.	SECTION	COUNTY	TOTAL SHEETS	SHEET NO.
1479	14-00124-04-BR	DUPAGE	208	199
				CONTRACT NO. 61114
		ILLINOIS	FED. AID PROJECT	

DATE	
BY	
SURVEYED	
PLOTTED	
TEMPLATE	
AREAS	
CHECKED	
FINAL SURVEY	
NOTE BOOK	
NO.	

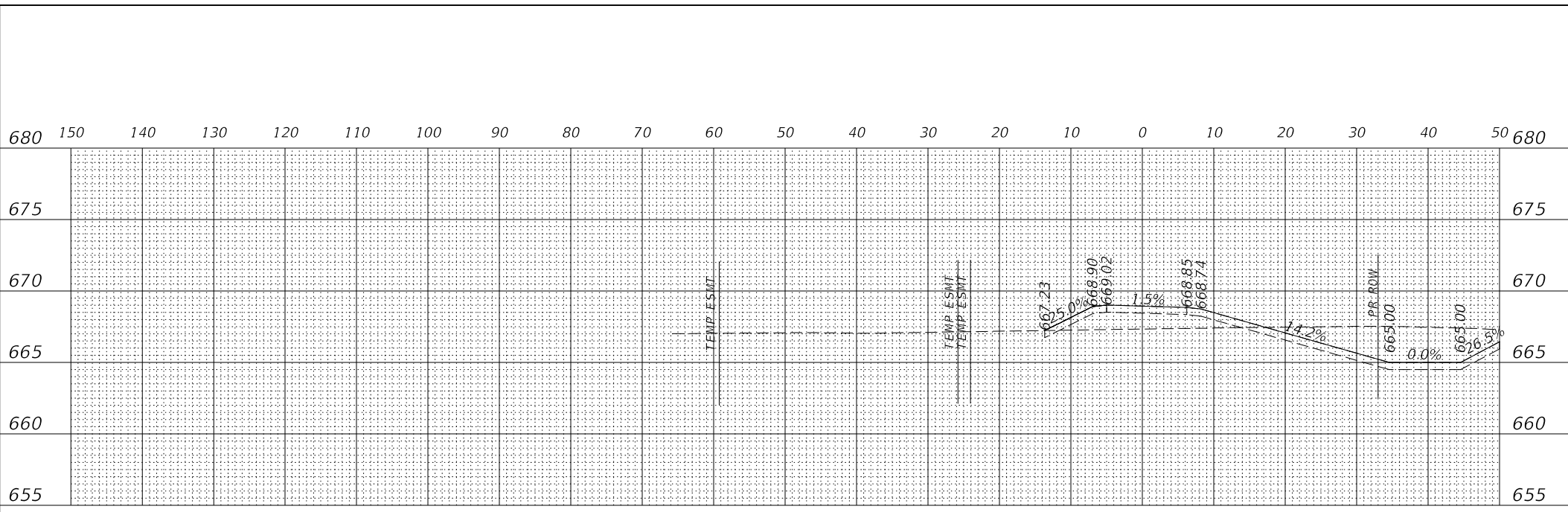

END AREAS CALCULATED
ON MAIN LINE CROSS SECTIONS
GRADING FOR FUTURE
MULT-USE PATH

11 + 00.00 R1

DATE	
BY	
SURVEYED	
PLOTTED	
TEMPLATE	
AREAS	
CHECKED	
ORIGINAL SURVEY	
NOTE BOOK	
NO.	

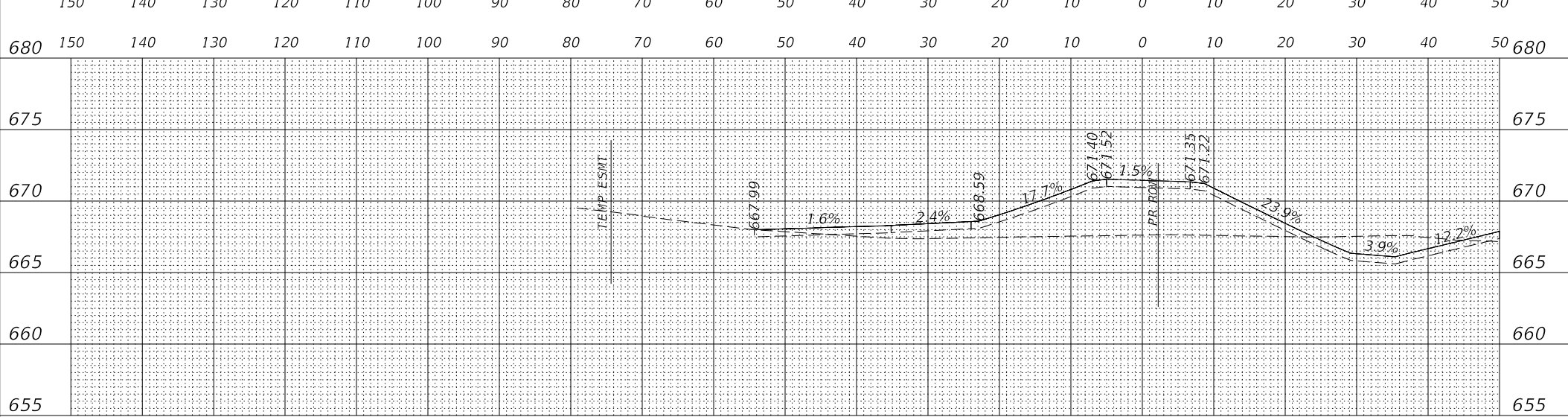

END AREAS CALCULATED
ON MAIN LINE CROSS SECTIONS
GRADING FOR FUTURE
MULT-USE PATH

10 + 50.00 R1

DATE	
BY	
SURVEYED	
PLOTTED	
TEMPLATE	
AREAS	
CHECKED	
ORIGINAL SURVEY	
NOTE BOOK	
NO.	

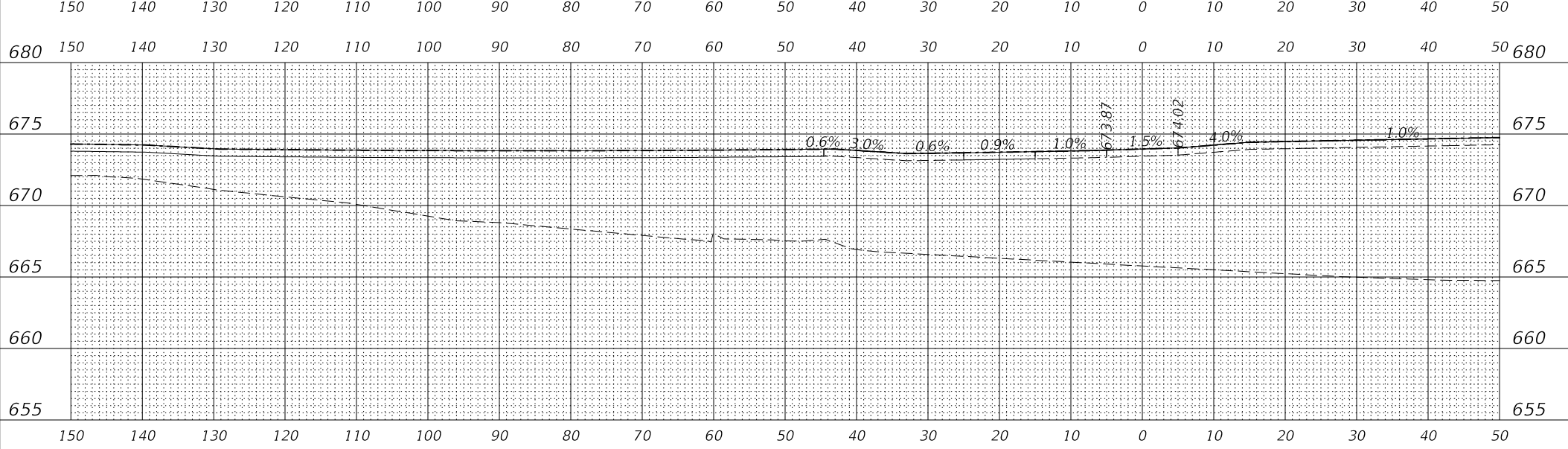

END AREAS CALCULATED
ON MAIN LINE CROSS SECTIONS
GRADING FOR FUTURE
MULT-USE PATH

10 + 00.00 R1

MODEL: \$P01\ENAMES
FILE NAME: I:\14-00\CAD\Drawings\Sheets\19102-ah-Xsec.dgn



USER NAME = USZE706065	DESIGNED - D.M.S.	REVISED -
	DRAWN - D.M.S.	REVISED -
PLOT SCALE = 1"=10' H : 1"=5' V	CHECKED - J.R.S.	REVISED -
PLOT DATE = 2/8/2024	DATE - 8/12/22	REVISED -

**STATE OF ILLINOIS
DEPARTMENT OF TRANSPORTATION**

**PROPOSED CROSS SECTIONS
FUTURE MULTI-USE PATH**

SCALE: 20 SHEET 1 OF 6 SHEETS STA. 10+00.00 R1 TO STA. 11+00.00 R1

F.A. RTE.	SECTION	COUNTY	TOTAL SHEETS	SHEET NO.
1479	14-00124-04-BR	DUPAGE	208	200
CONTRACT NO. 61114				
ILLINOIS		FED. AID PROJECT		

DATE	
BY	
SURVEYED	
PLOTTED	
TEMPLATE	
AREAS	
CHECKED	
FINAL SURVEY	
NOTE BOOK	
NO.	

DATE	
BY	
SURVEYED	
PLOTTED	
TEMPLATE	
AREAS	
CHECKED	
ORIGINAL SURVEY	
NOTE BOOK	
NO.	

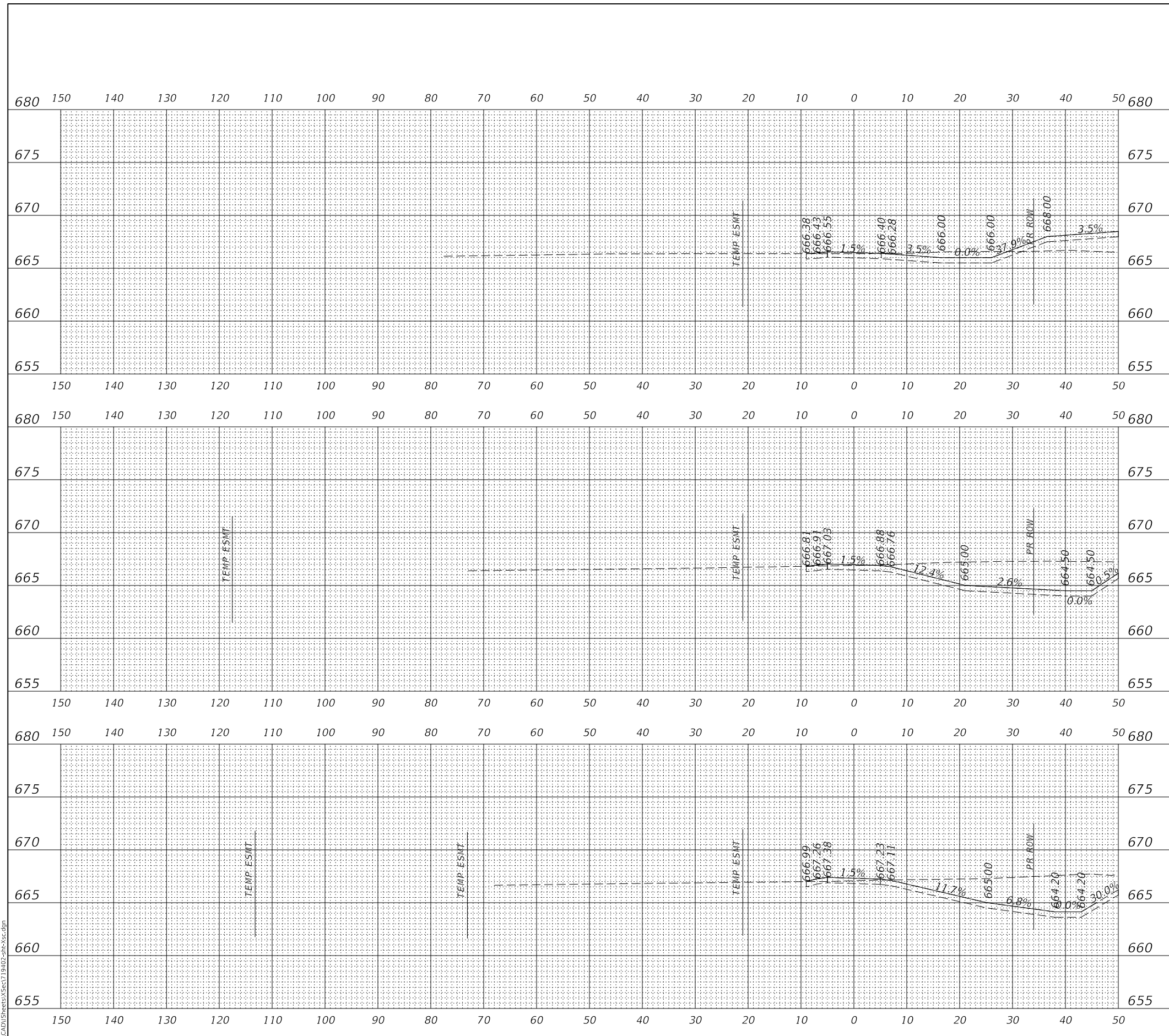

GRADING FOR FUTURE
MULT-USE PATH

12 + 46.25 R1

END AREAS CALCULATED
ON MAIN LINE CROSS SECTIONS
GRADING FOR FUTURE
MULT-USE PATH

12 + 00.00 R1

END AREAS CALCULATED
ON MAIN LINE CROSS SECTIONS
GRADING FOR FUTURE
MULT-USE PATH

11 + 50.00 R1

MODEL: \$MODELNAME\$
FILE NAME: I:\14-00\CAD\Drawings\Sheet\19102-sh-Xsec.dgn



USER NAME = USZE706065	DESIGNED - D.M.S.	REVISED -
	DRAWN - D.M.S.	REVISED -
PLOT SCALE = 1"=10' H : 1"=5' V	CHECKED - J.R.S.	REVISED -
PLOT DATE = 2/8/2024	DATE - 8/12/22	REVISED -

**STATE OF ILLINOIS
DEPARTMENT OF TRANSPORTATION**

**PROPOSED CROSS SECTIONS
FUTURE MULTI-USE PATH**

SCALE: 20 SHEET 2 OF 6 SHEETS STA. 11+50.00 R1 TO STA. 12+46.25 R1

F.A. RTE.	SECTION	COUNTY	TOTAL SHEETS	SHEET NO.
1479	14-00124-04-BR	DUPAGE	208	201
CONTRACT NO. 61114				
ILLINOIS		FED. AID PROJECT		

FINAL SURVEY NO.	SURVEYED	BY	DATE
NOTE BOOK	PLOTTED		
AREAS CHECKED	TEMPLATE		
	AREAS		
	CHECKED		

ORIGINAL SURVEY NO.	SURVEYED	BY	DATE
NOTE BOOK	PLOTTED		
AREAS CHECKED	TEMPLATE		
	AREAS		
	CHECKED		

MODEL: \$MODELNAME\$
FILE NAME: I:\14-00\CADD\Sheets\14-00124-04-01-12-2024-12-2024.dwg

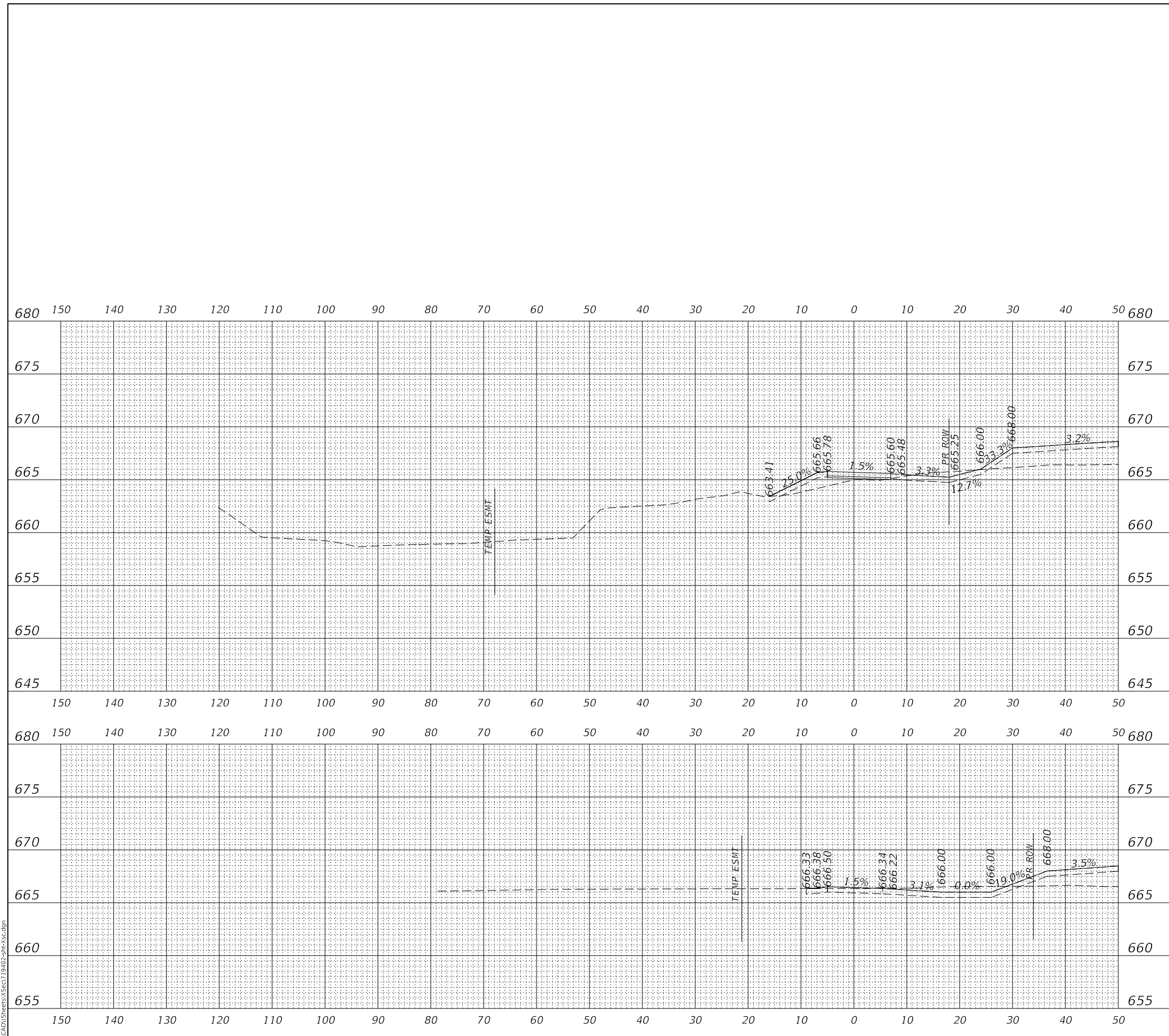

13+00.00 R1

12+50.00 R1

GRADING FOR FUTURE
MULTI-USE PATH



USER NAME = USZE706065	DESIGNED - D.M.S.	REVISED -
PLOT SCALE = 1"=10' H : 1"=5' V	DRAWN - D.M.S.	REVISED -
PLOT DATE = 2/8/2024	CHECKED - J.R.S.	REVISED -
	DATE - 8/12/22	REVISED -

STATE OF ILLINOIS
DEPARTMENT OF TRANSPORTATION

PROPOSED CROSS SECTIONS
FUTURE MULTI-USE PATH

SCALE: 20 SHEET 3 OF 6 SHEETS STA. 12+50.00 R1 TO STA. 13+00.00 R1

F.A. RTE.	SECTION	COUNTY	TOTAL SHEETS	SHEET NO.
1479	14-00124-04-BR	DUPAGE	208	202
CONTRACT NO. 61114				
ILLINOIS FED. AID PROJECT				

FINAL SURVEY NO.	SURVEYED	DATE
NOTE BOOK	PLOTTED	
	TEMPLATE	
	AREAS CHECKED	

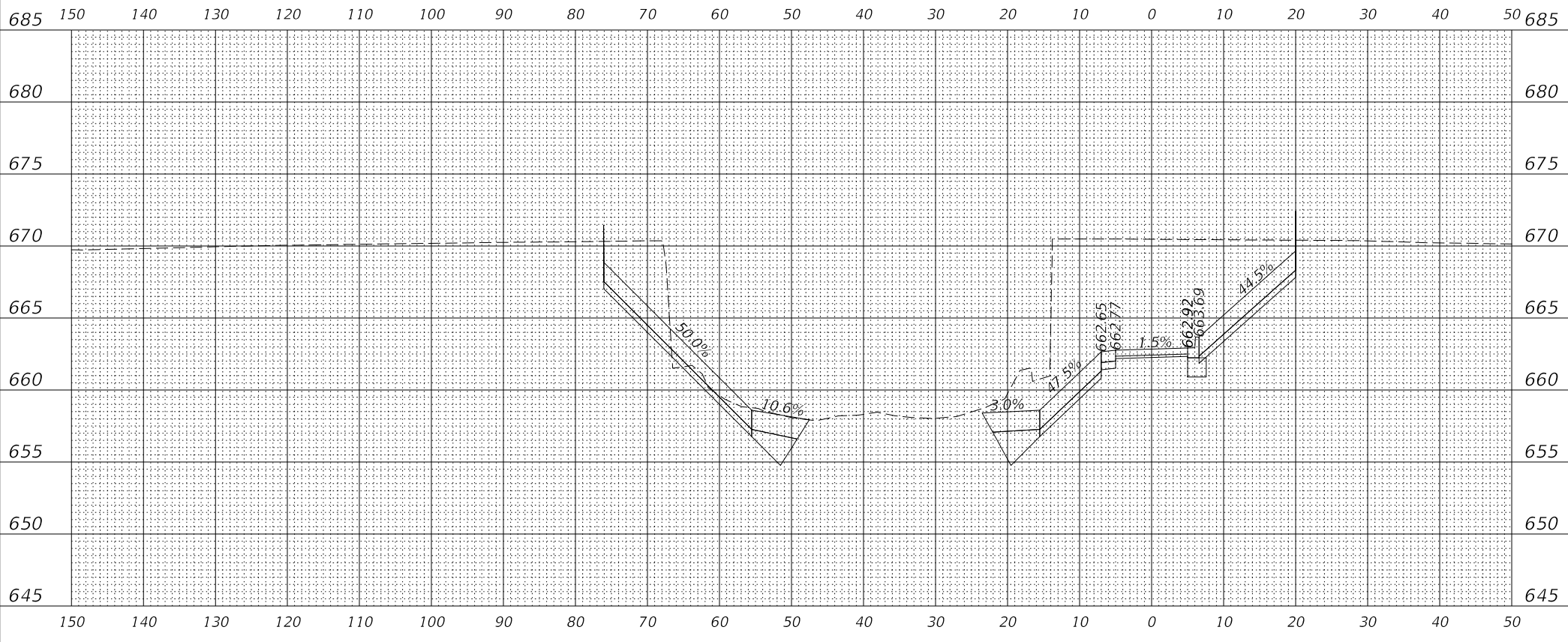

14 + 00.00 R1

ORIGINAL SURVEY NO.	SURVEYED	DATE
NOTE BOOK	PLOTTED	
	TEMPLATE	
	AREAS CHECKED	

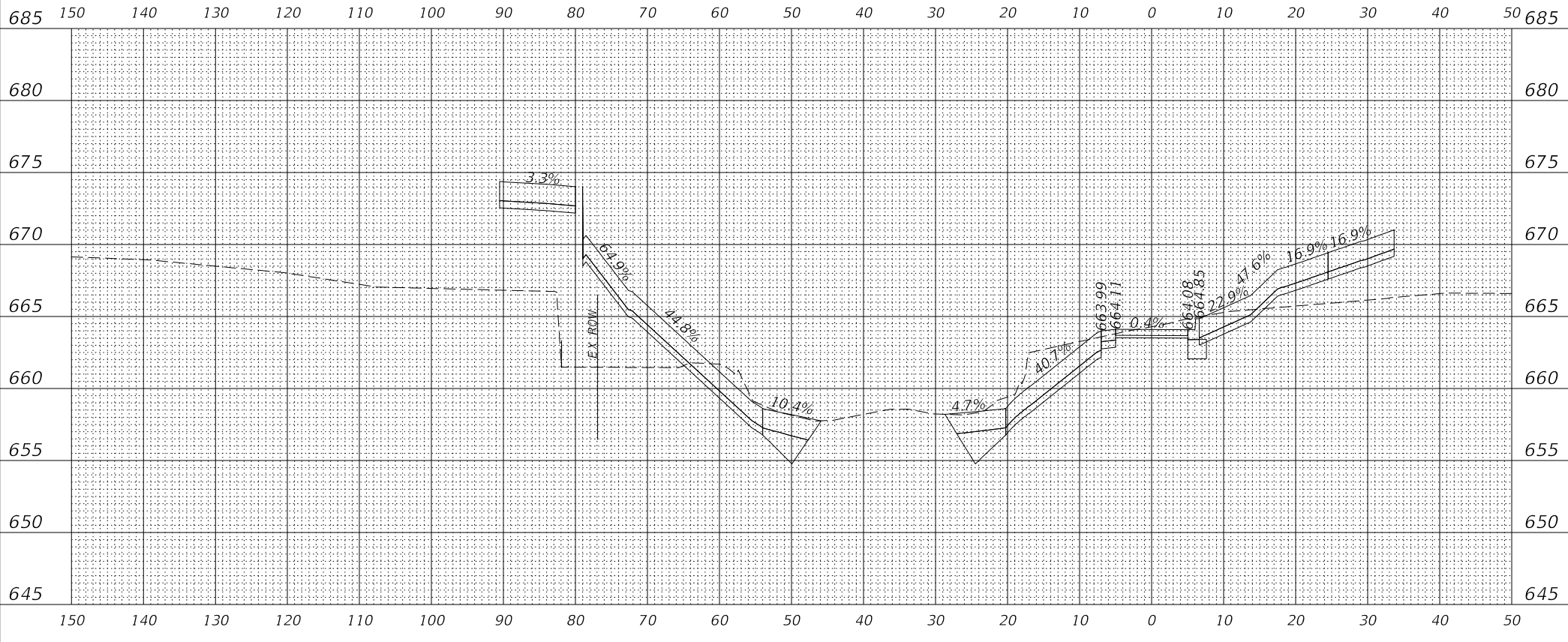

13 + 50.00 R1

MODEL: \$MODELNAME\$
FILE NAME: I:\14\CD\AD\Sheets\19102-ah-xsec.dgn



USER NAME = USZE706065	DESIGNED - D.M.S.	REVISED -
	DRAWN - D.M.S.	REVISED -
PLOT SCALE = 1"=10' H : 1"=5' V	CHECKED - J.R.S.	REVISED -
PLOT DATE = 2/8/2024	DATE - 8/12/22	REVISED -

STATE OF ILLINOIS
DEPARTMENT OF TRANSPORTATION

PROPOSED CROSS SECTIONS
FUTURE MULTI-USE PATH

SCALE: 20 SHEET 4 OF 6 SHEETS STA. 13+50.00 R1 TO STA. 14+00.00 R1

F.A. RTE.	SECTION	COUNTY	TOTAL SHEETS	SHEET NO.
1479	14-00124-04-BR	DUPAGE	208	203
CONTRACT NO. 61114				
ILLINOIS FED. AID PROJECT				

FINAL SURVEY NO.	SURVEYED	DATE
NOTE BOOK	PLOTTED	BY
NO.	TEMPLATE	
	AREAS CHECKED	

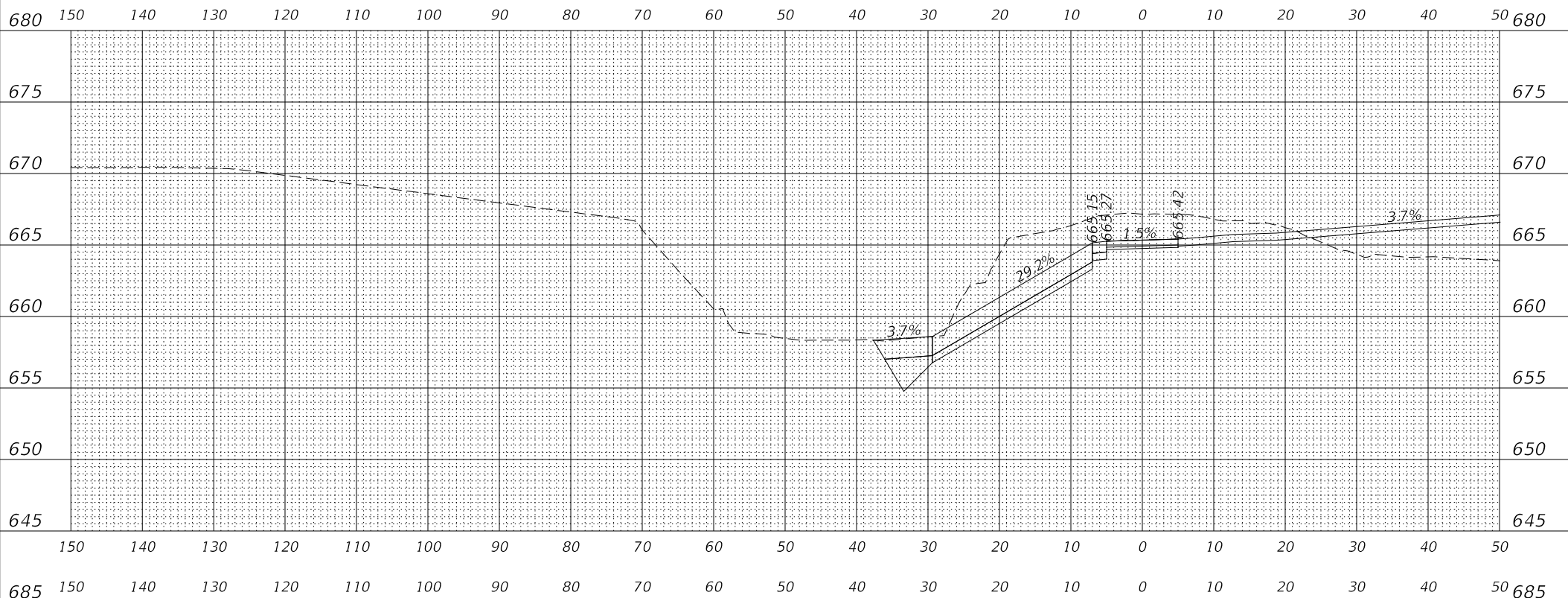

15 + 00.00 R1

ORIGINAL SURVEY NO.	SURVEYED	DATE
NOTE BOOK	PLOTTED	BY
NO.	TEMPLATE	
	AREAS CHECKED	

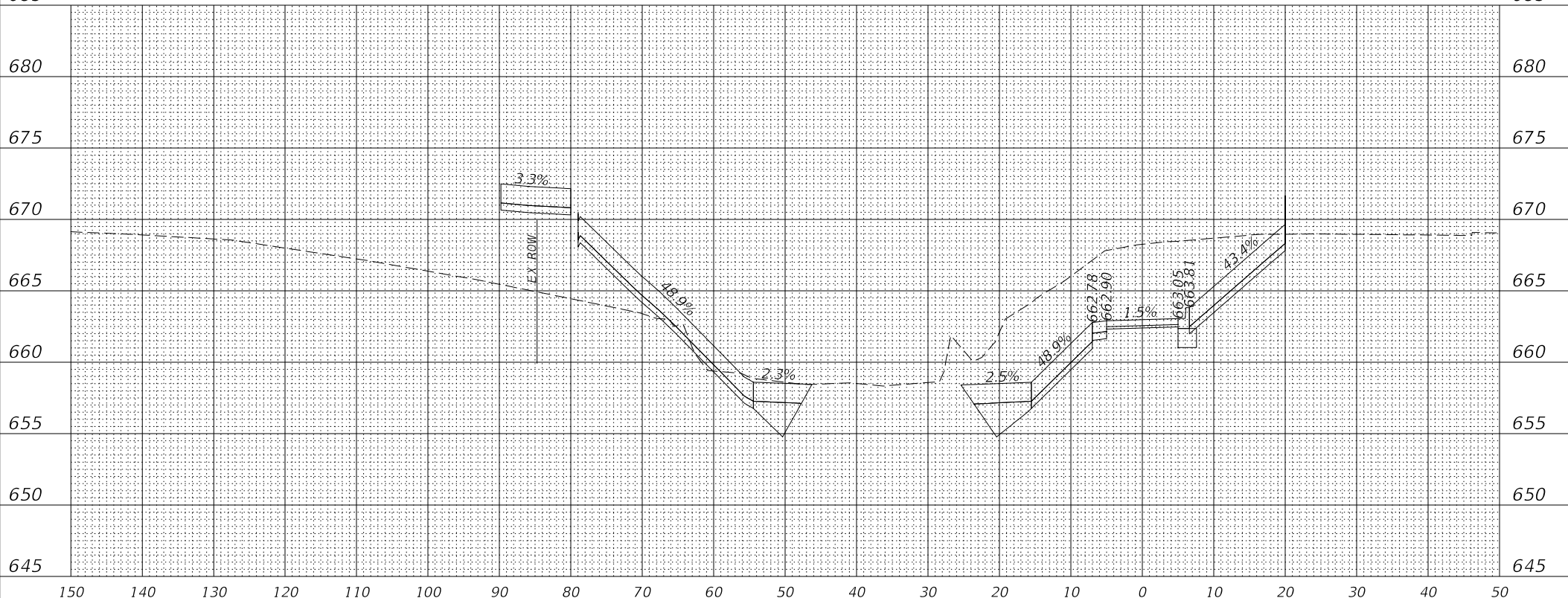

14 + 50.00 R1

MODEL: \$P01\ENAMES
FILE NAME: I:\14\CD\AD\Drawings\Sheet\19102-ah-xsec.dgn



USER NAME = USZE706065	DESIGNED - D.M.S.	REVISED -
PLOT SCALE = 1"=10' H : 1"=5' V	DRAWN - D.M.S.	REVISED -
PLOT DATE = 2/8/2024	CHECKED - J.R.S.	REVISED -
	DATE - 8/12/22	REVISED -

STATE OF ILLINOIS
DEPARTMENT OF TRANSPORTATION

PROPOSED CROSS SECTIONS
FUTURE MULTI-USE PATH

SCALE: 20 SHEET 5 OF 6 SHEETS STA. 14+50.00 R1 TO STA. 15+00.00 R1

F.A. RTE.	SECTION	COUNTY	TOTAL SHEETS	SHEET NO.
1479	14-00124-04-BR	DUPAGE	208	204
CONTRACT NO. 61114				
ILLINOIS FED. AID PROJECT				

FINAL SURVEY NO.	SURVEYED PLOTTED AREAS CHECKED	BY	DATE

ORIGINAL SURVEY NO.	SURVEYED PLOTTED AREAS CHECKED	BY	DATE

MODEL: \$MODELNAME\$
FILE NAME: I:\14-00124\Drawings\Sheet\14-00124-04-BR.dwg

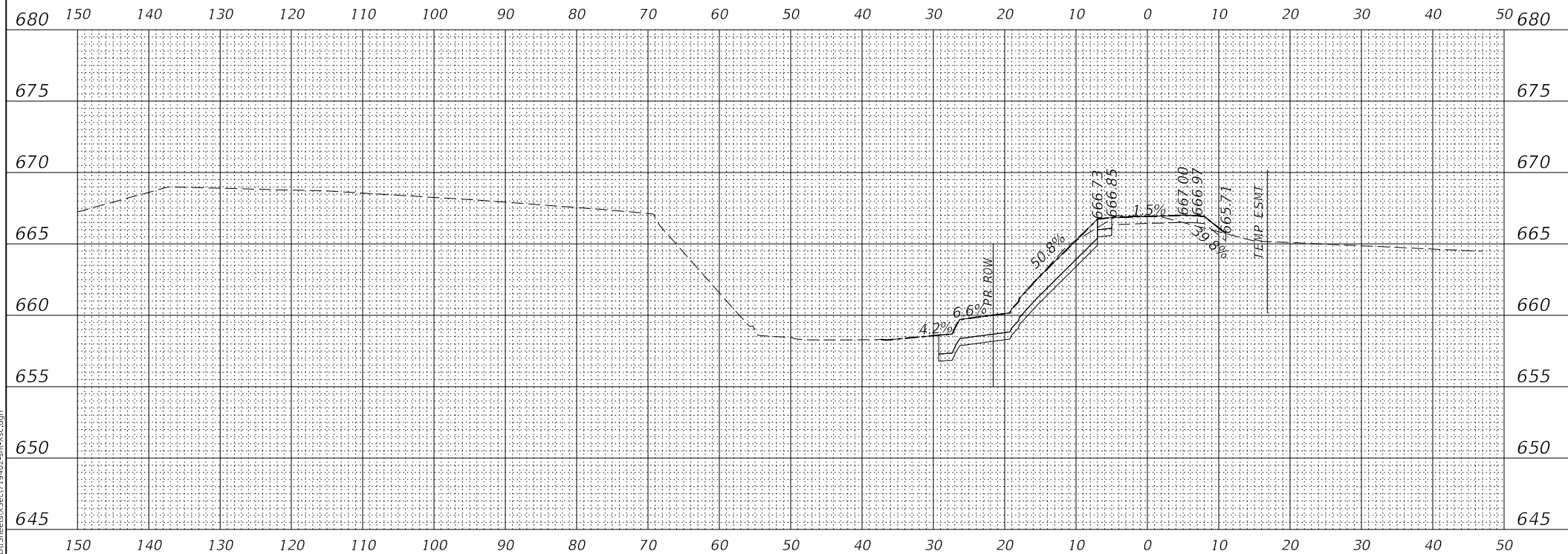

15 + 31.57 R1



USER NAME = USZE706065
PLOT SCALE = 1"=10' H : 1"=5' V
PLOT DATE = 2/8/2024

DESIGNED - D.M.S.
DRAWN - D.M.S.
CHECKED - J.R.S.
DATE - 8/12/22

REVISED -
REVISED -
REVISED -
REVISED -

STATE OF ILLINOIS
DEPARTMENT OF TRANSPORTATION

PROPOSED CROSS SECTIONS
FUTURE MULTI-USE PATH

SCALE: 20 SHEET 6 OF 6 SHEETS STA. 15+31.57 R1 TO STA. 15+31.57 R1

F.A. RTE.	SECTION	COUNTY	TOTAL SHEETS	SHEET NO.
1479	14-00124-04-BR	DUPAGE	208	205
CONTRACT NO. 61114				
ILLINOIS FED. AID PROJECT				

FINAL SURVEY NO.	SURVEYED	BY	DATE
NOTE BOOK	PLOTTED		
	TEMPLATE		
	AREAS		
	CHECKED		

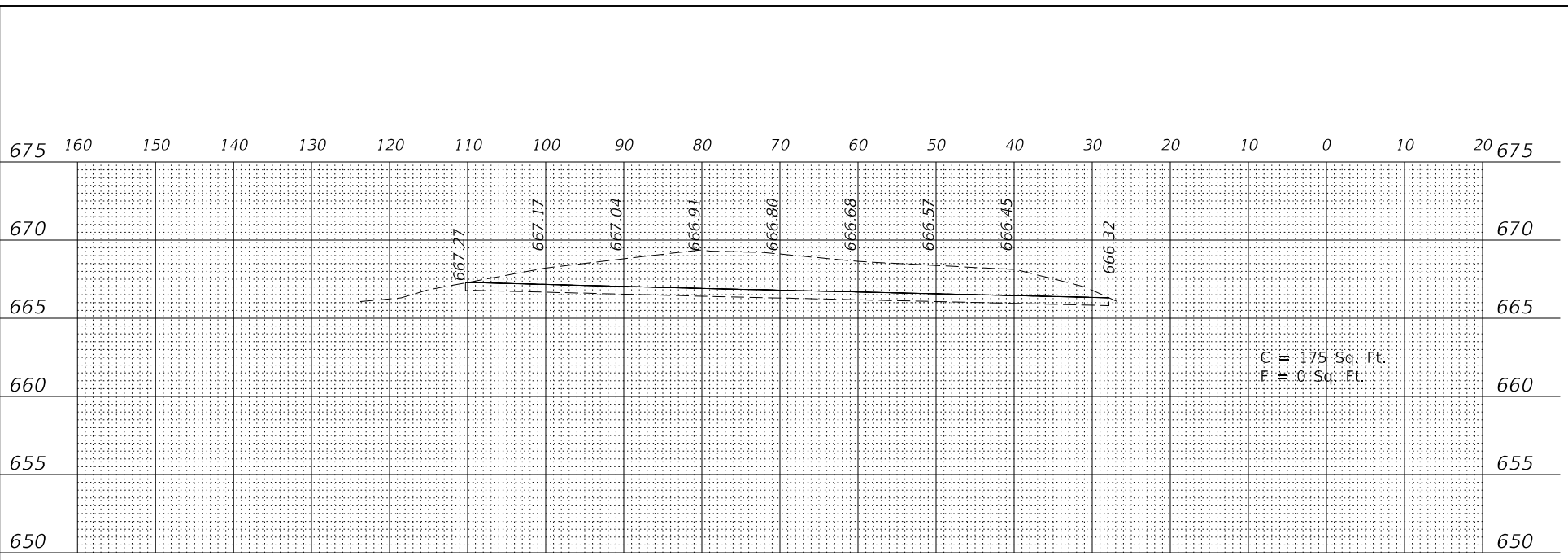

1010 + 00.00 R1

ORIGINAL SURVEY NO.	SURVEYED	BY	DATE
NOTE BOOK	PLOTTED		
	TEMPLATE		
	AREAS		
	CHECKED		

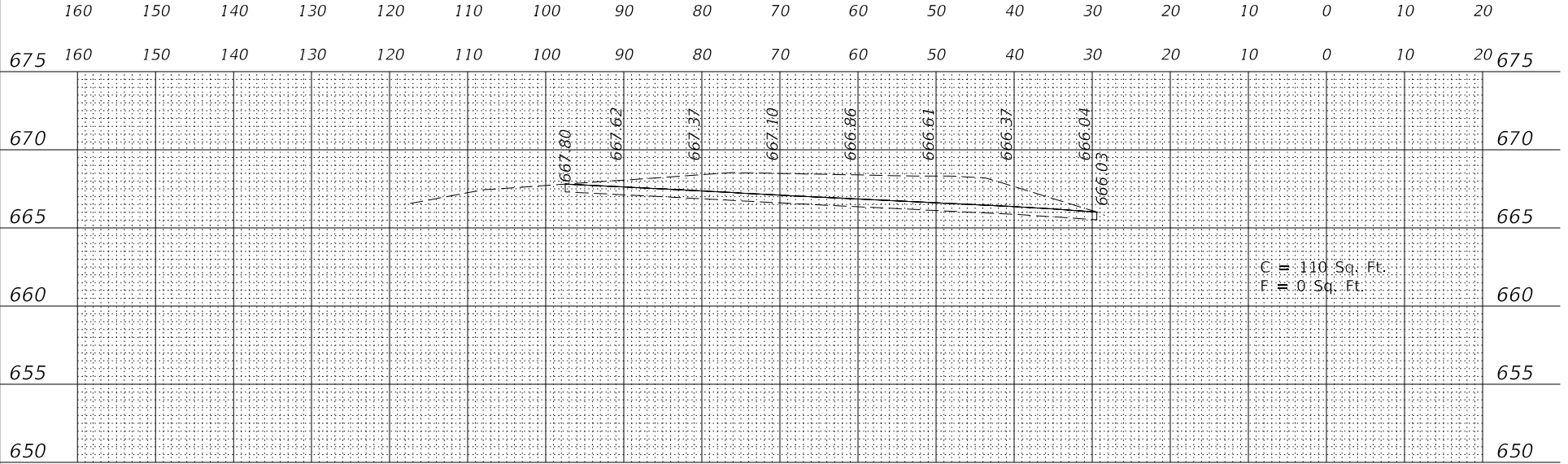

1009 + 50.00 R1

MODEL: \$MODELNAME\$	SURVEYED	BY	DATE
FILE NAME: I:\14-00124\Drawings\Sheets\61114-01-2014-08-12-2014.dwg	PLOTTED		
	TEMPLATE		
	AREAS		
	CHECKED		

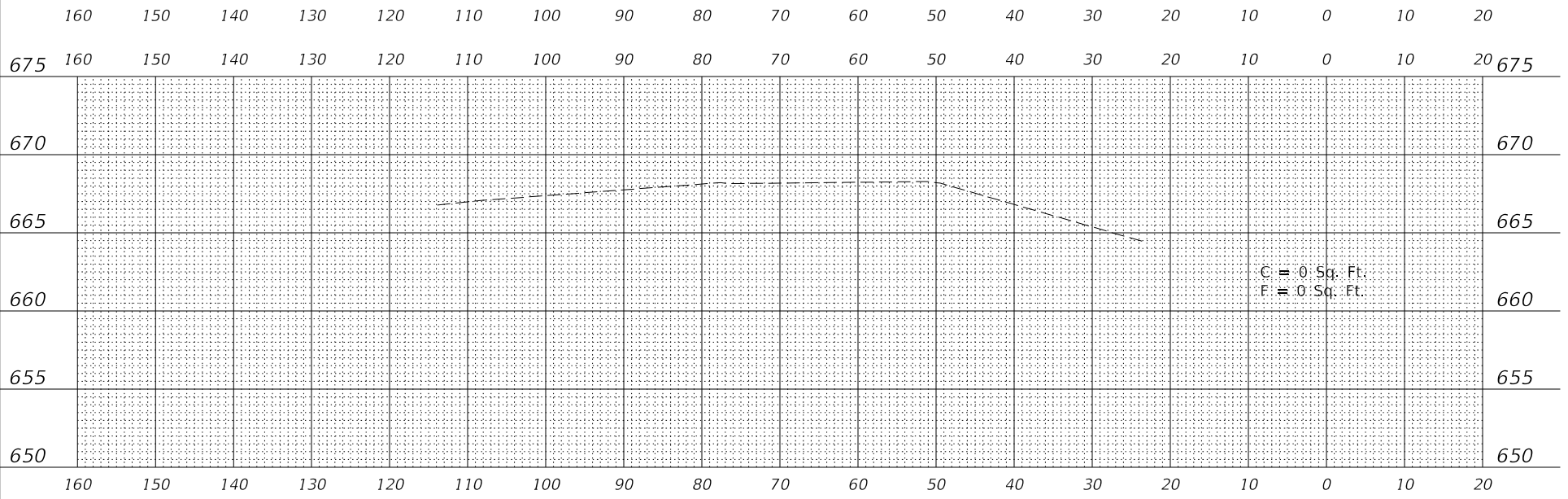

1009 + 00.00 R1



USER NAME = USZE706065	DESIGNED - D.M.S.	REVISED -
	DRAWN - D.M.S.	REVISED -
PLOT SCALE = 1"=10' H : 1"=5' V	CHECKED - J.R.S.	REVISED -
PLOT DATE = 2/8/2024	DATE - 8/12/22	REVISED -

STATE OF ILLINOIS
DEPARTMENT OF TRANSPORTATION

PROPOSED CROSS SECTIONS
COMPENSATORY STORAGE

SCALE: 20 SHEET 1 OF 3 SHEETS STA. 1009+00.00 R1 TO STA. 1010+00.00 R1

F.A. RTE.	SECTION	COUNTY	TOTAL SHEETS	SHEET NO.
1479	14-00124-04-BR	DUPAGE	208	206
CONTRACT NO. 61114				
ILLINOIS FED. AID PROJECT				

FINAL SURVEY NO.	SURVEYED	BY	DATE
NOTE BOOK	PLOTTED		
	TEMPLATE		
	AREAS		
	CHECKED		

ORIGINAL SURVEY NO.	SURVEYED	BY	DATE
NOTE BOOK	PLOTTED		
	TEMPLATE		
	AREAS		
	CHECKED		

MODEL: \$MODELNAME\$
FILE NAME: I:\14-00\CADD\Sheets\61114\1011+50.00 R1.dwg

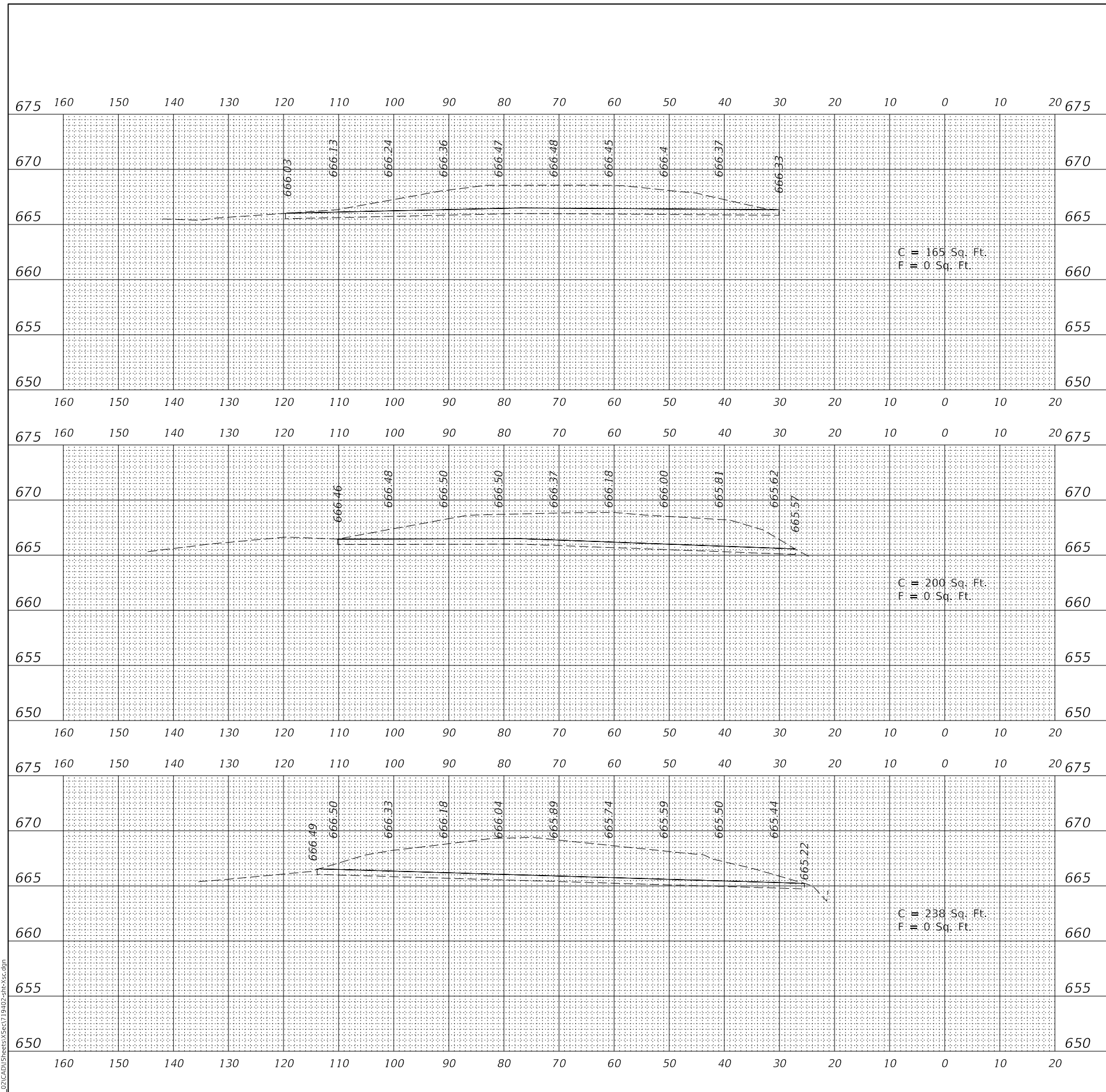

1011 + 50.00 R1

1011 + 00.00 R1

1010 + 50.00 R1



USER NAME = USZE706065	DESIGNED - D.M.S.	REVISED -
PLOT SCALE = 1"=10' H : 1"=5' V	DRAWN - D.M.S.	REVISED -
PLOT DATE = 2/8/2024	CHECKED - J.R.S.	REVISED -
	DATE - 8/12/22	REVISED -

**STATE OF ILLINOIS
DEPARTMENT OF TRANSPORTATION**

**PROPOSED CROSS SECTIONS
COMPENSATORY STORAGE**

SCALE: 20 SHEET 2 OF 3 SHEETS STA. 1010+50.00 R1 TO STA. 1011+50.00 R1

F.A. RTE.	SECTION	COUNTY	TOTAL SHEETS	SHEET NO.
1479	14-00124-04-BR	DUPAGE	208	207
CONTRACT NO. 61114				
ILLINOIS FED. AID PROJECT				

FINAL SURVEY NO.	SURVEYED	BY	DATE
NOTE BOOK	PLOTTED		
AREAS CHECKED	TEMPLATE		
	AREAS		
	CHECKED		

ORIGINAL SURVEY NO.	SURVEYED	BY	DATE
NOTE BOOK	PLOTTED		
AREAS CHECKED	TEMPLATE		
	AREAS		
	CHECKED		

MODEL: \$MODELNAME\$
FILE NAME: I:\14-00124\Drawings\Sheets\19102-sh-28.dgn

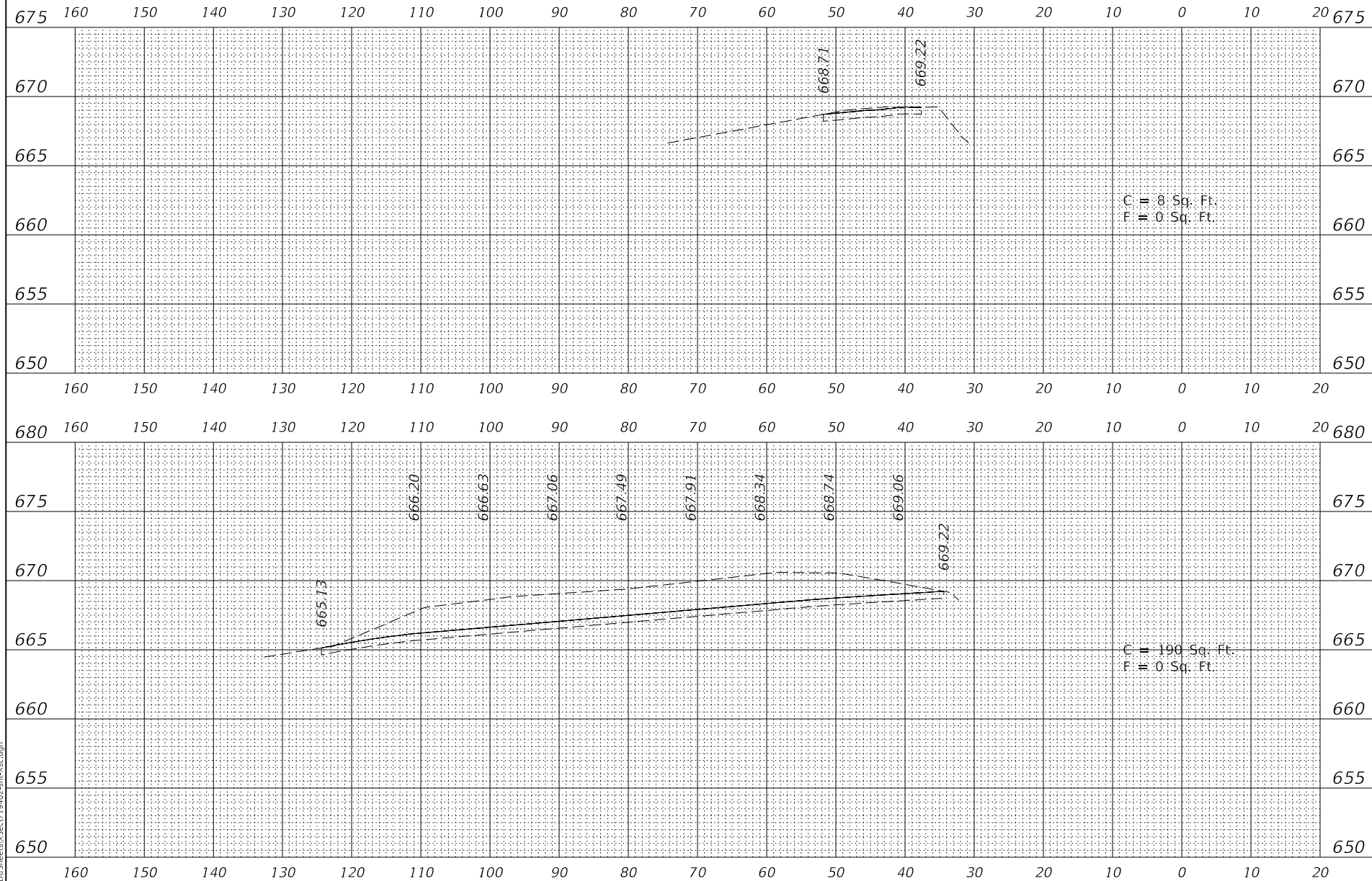

1012 + 50.00 R1

1012 + 00.00 R1



USER NAME = USZE706065
PLOT SCALE = 1"=10' H : 1"=5' V
PLOT DATE = 2/8/2024

DESIGNED - D.M.S.
DRAWN - D.M.S.
CHECKED - J.R.S.
DATE - 8/12/22

REVISED -
REVISED -
REVISED -
REVISED -

STATE OF ILLINOIS
DEPARTMENT OF TRANSPORTATION

PROPOSED CROSS SECTIONS
COMPENSATORY STORAGE

SCALE: 20 SHEET 3 OF 3 SHEETS STA. 1012+00.00 R1 TO STA. 1012+75.00 R1

F.A. RTE.	SECTION	COUNTY	TOTAL SHEETS	SHEET NO.
1479	14-00124-04-BR	DUPAGE	208	208
			CONTRACT NO. 61114	
		ILLINOIS	FED. AID PROJECT	