

* Center of horizontal to center of splice dimension may vary. Verify before drilling holes in mounting tube.

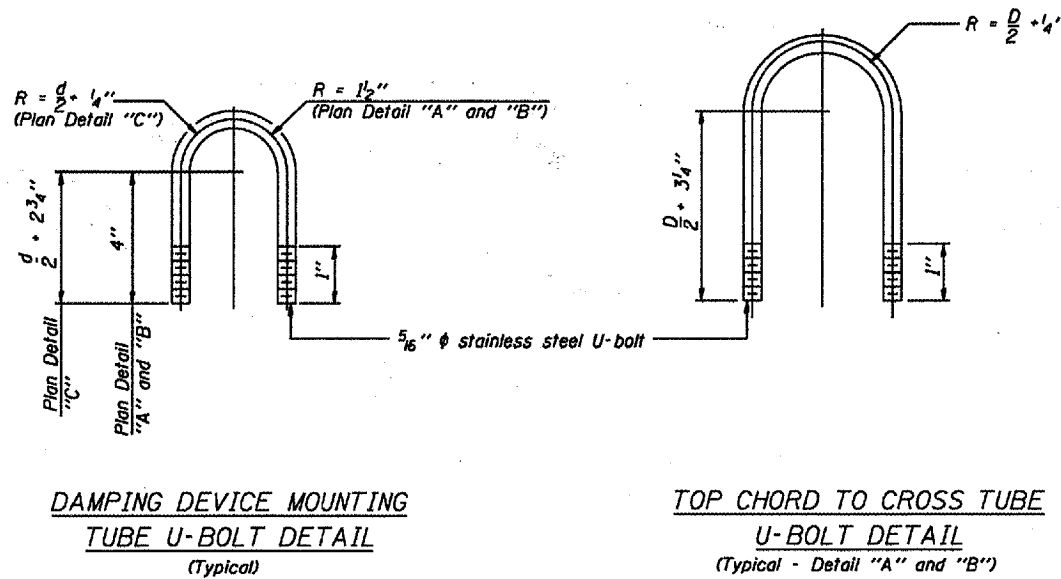
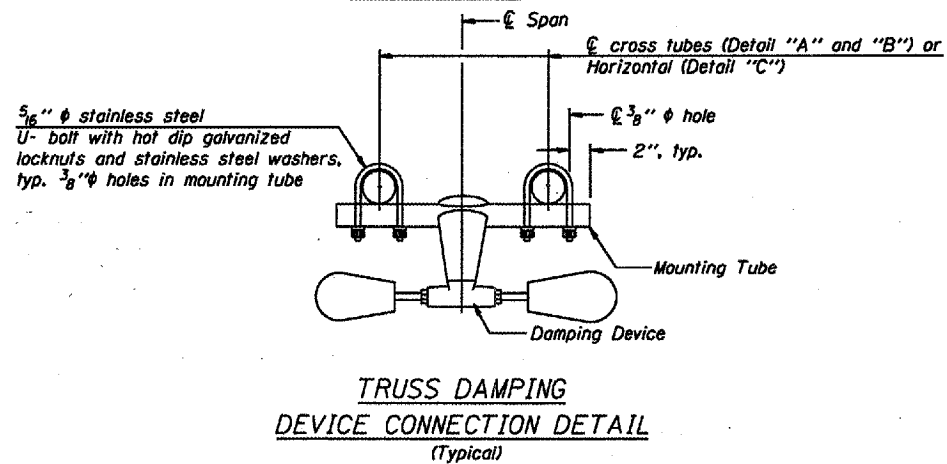
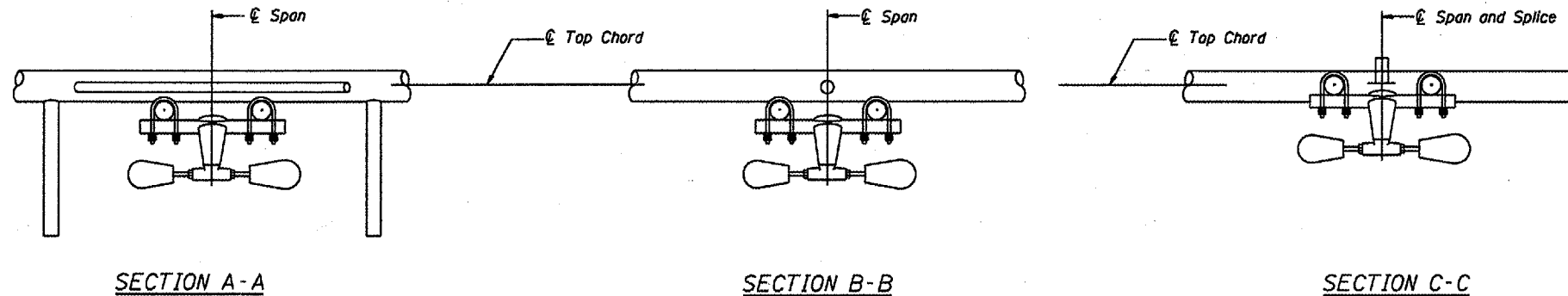
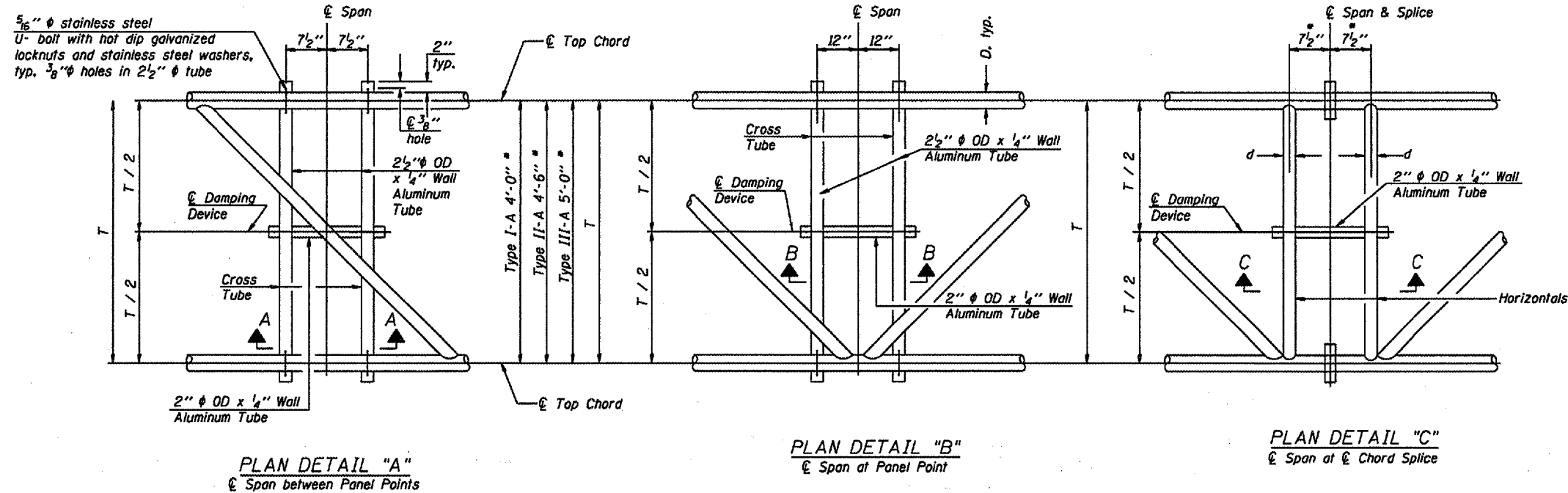

DESIGNED -	20
CHECKED -	EXAMINED
DRAWN -	PASSED
CHECKED -	ENGINEER OF BRIDGES AND STRUCTURES

OS-A-D

7/01/2006

OVERHEAD SIGN STRUCTURE
DAMPING DEVICE

District 5
Overhead Sign
Structure Replacement