

70513

F.A.I. RTE.	SECTION	COUNTY	TOTAL SHEETS	SHEET NO.
55		MCLEAN	87	1
FED. ROAD DIST. NO. 4		ILLINOIS	FED. AID PROJECT	
(57-4)RS-3 & I				
P-93-038-03				
D-93-046-04				

87+2=89

**STATE OF ILLINOIS
DEPARTMENT OF TRANSPORTATION
DIVISION OF HIGHWAYS**

F.A.I. 55 (I-55)

SECTION (57-4) RS-3 & I

PROJECT IM-055-4 (167)164

TYPE OF IMPROVEMENT: RESURFACING

MCLEAN COUNTY

C-95-034-06

INDEX OF SHEETS

- 1 COVER SHEET
- 2 GENERAL NOTES
- 3-5 SUMMARY OF QUANTITIES
- 6-23 TYPICAL SECTIONS
- 24-26 SCHEDULE OF QUANTITIES
- 27-32 DOUBLE PLAN SHEETS
- 33-45 STAGE CONSTRUCTION DETAILS
- 46-51 PAVEMENT MARKING DETAILS
- 52-55 DETAILS
- 56-58 STRUCTURE PLANS (SN 057-0214 & 0215)
- 59-68 STRUCTURE PLANS (SN 057-0024 & 0025)
- 69-82 STRUCTURE PLANS (SN 057-0026 & 0027)
- 83-87 STRUCTURE PLANS (SN 057-0028 & 0029)

HIGHWAY STANDARDS

- 000001-04 STANDARD SYMBOLS, ABBREVIATIONS, AND PATTERNS
- 280001-03 TEMPORARY EROSION CONTROL SYSTEMS
- 285001-01 FABRIC FORMED CONCRETE REVETMENT MAT
- 420001-06 PAVEMENT JOINTS
- 442001-03 CLASS A PATCHES
- 542401 METAL END SECTION FOR PIPE CULVERTS
- 601101 CONCRETE HEADWALL FOR PIPE DRAIN
- 610001-03 SHOULDER INLET WITH CURB
- 630001-07 STEEL PLATE BEAM GUARDRAIL
- 630301-04 SHOULDER WIDENING FOR TYPE 1 (SPECIAL) GUARDRAIL TERMINALS
- 631031-06 TRAFFIC BARRIER TERMINAL, TYPE 6
- 631032-03 TRAFFIC BARRIER TERMINAL, TYPE 6A
- 635006-02 REFLECTOR AND TERMINAL MARKER PLACEMENT
- 635011-01 REFLECTOR MARKER AND MOUNTING DETAILS
- 642001 SHOULDER RUMBLE STRIPS
- 665001-01 WOVEN WIRE FENCE
- 701101-01 OFF-RD OPERATIONS, MULTILANE, 4.5 m (15') TO 600 mm (24") FROM PAVEMENT EDGE
- 701106-01 OFF-RD OPERATIONS, MULTILANE, MORE THAN 4.5m (15') AWAY
- 701400-02 APPROACH TO LANE CLOSURE, FREEWAY/EXPRESSWAY
- 701401-03 LANE CLOSURE, FREEWAY/EXPRESSWAY
- 701402-05 LANE CLOSURE, FREEWAY/EXPRESSWAY WITH BARRIER
- 701406-04 LANE CLOSURE, FREEWAY/EXPRESSWAY, DAY OPERATIONS ONLY
- 701411-03 LANE CLOSURE, MULTILANE, AT ENTRANCE OR EXIT RAMP, FOR SPEEDS \leq 45 MPH
- 701426-02 LANE CLOSURE, MULTILANE, INTERMITTENT OR MOVING OPERATION, FOR SPEEDS \leq 45 MPH
- 701446 TWO LANE CLOSURE, FREEWAY/EXPRESSWAY
- 702001-06 TRAFFIC CONTROL DEVICES
- 704001-03 TEMPORARY CONCRETE BARRIER
- 780001-01 TYPICAL PAVEMENT MARKINGS
- 781001-02 TYPICAL APPLICATIONS RAISED REFLECTIVE PAVEMENT MARKERS

UTILITY NOTE

THE LOCATIONS OF THOSE BURIED AND ABOVEGROUND UTILITIES SHOWN ARE APPROXIMATE, ARE SHOWN FOR CONTRACTOR INFORMATIONAL USE ONLY, AND ARE NOT TO BE REFERENCED FOR CONSTRUCTION PURPOSES. THE IMPLIED PRESENCE OR ABSENCE OF UTILITIES IS NOT TO BE CONSTRUED BY THE OWNER, ENGINEER, CONTRACTOR, OR SUBCONTRACTORS TO BE AN ACCURATE AND COMPLETE REPRESENTATION OF UTILITIES THAT MAY OR MAY NOT EXIST ON THE CONSTRUCTION SITE. BURIED AND ABOVEGROUND UTILITY LOCATION, IDENTIFICATION, AND MARKING ARE THE SOLE RESPONSIBILITY OF THE CONTRACTOR. REROUTING, DISCONNECTION, PROTECTION, ETC. OF ANY UTILITIES MUST BE COORDINATED BETWEEN THE CONTRACTOR, UTILITY COMPANY, AND OWNER. SITE SAFETY, INCLUDING THE AVOIDANCE OF HAZARDS ASSOCIATED WITH BURIED AND ABOVEGROUND UTILITIES, REMAIN THE SOLE RESPONSIBILITY OF THE CONTRACTOR.

FULL SIZE PLANS HAVE BEEN PREPARED USING STANDARD ENGINEERING SCALES, REDUCED SIZED PLANS WILL NOT CONFORM TO STANDARD SCALES, IN MAKING MEASUREMENTS ON REDUCED PLANS, THE ABOVE SCALES MAY BE USED.

MICROFILMED _____
REEL NUMBER _____
AWARDED _____
RESIDENT ENGINEER _____
AS BUILT CHANGES WERE MADE ON THE FOLLOWING SHEETS _____

FOR JOINT UTILITY INFORMATION CALL TOLLFREE
1-800-892-0123

DISTRICT 3 PHONE # 815-434-6131
PROJECT ENGINEER: JOE KANNEL
UNIT CHIEF: MICHELE LINDEMANN
TOWNSHIP: NORMAL

CONTRACT NO. 70513

PLAN 1:500
PROFILE HORIZ. 1:500
PROFILE VERT. 1:50
CROSS SECTIONS 1:100

METRIC RATIOS

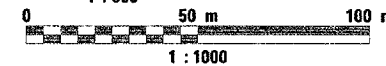
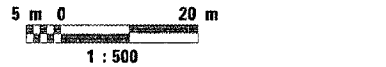
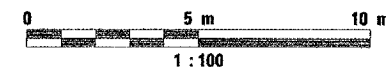

BEGIN IMPROVEMENT STA. 36+305 (F.A.I. 55)

END IMPROVEMENT STA. 40+486 (F.A.I. 55)

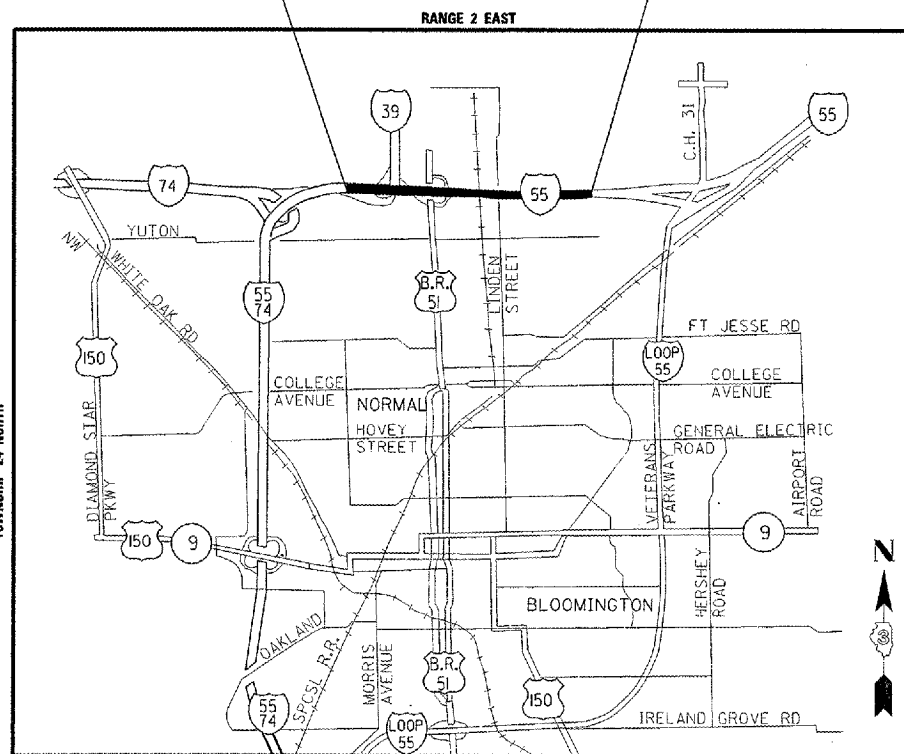

LOCATION MAP
MAP SCALE 1 : 60,000

SCALE : 1 0 1 2 KILOMETER

GROSS LENGTH OF PROJECT = 4.181 km
NET LENGTH OF PROJECT = 4.181 km

STRUCTURE DESCRIPTION

STRUCTURE NO. 057-0214 (S.B.) FOUR SPAN BRIDGE CARRYING RAMP A OVER F.A.I. 55. 83.201 m BK. TO BK. OF APPROACH BENTS - FOUNDATION & SLOPEWALL REPAIR.

STRUCTURE NO. 057-0215 (N.B.) FOUR SPAN BRIDGE CARRYING F.A.I. 39 OVER F.A.I. 55. 83.734 m BK. TO BK. OF APPROACH BENTS - FOUNDATION & SLOPEWALL REPAIR

STRUCTURE NO. 057-0024 & 057-0025 FOUR SPAN DUAL BRIDGE CARRYING F.A.I. 55 OVER U.S. 51. 63.884 m BK. TO BK. OF ABUTMENTS - DECK REPAIR.

STRUCTURE NO. 057-0026 & 057-0027 THREE SPAN DUAL BRIDGE CARRYING F.A.I. 55 OVER CONSTITUTION TRAIL. 46.231 m BK. TO BK. OF ABUTMENTS - DECK REPAIR.

STRUCTURE NO. 057-0028 & 057-0029 THREE SPAN DUAL BRIDGE CARRYING F.A.I. 55 OVER LINDEN STREET. 34.950 m BK. TO BK. OF ABUTMENTS - DECK REPAIR

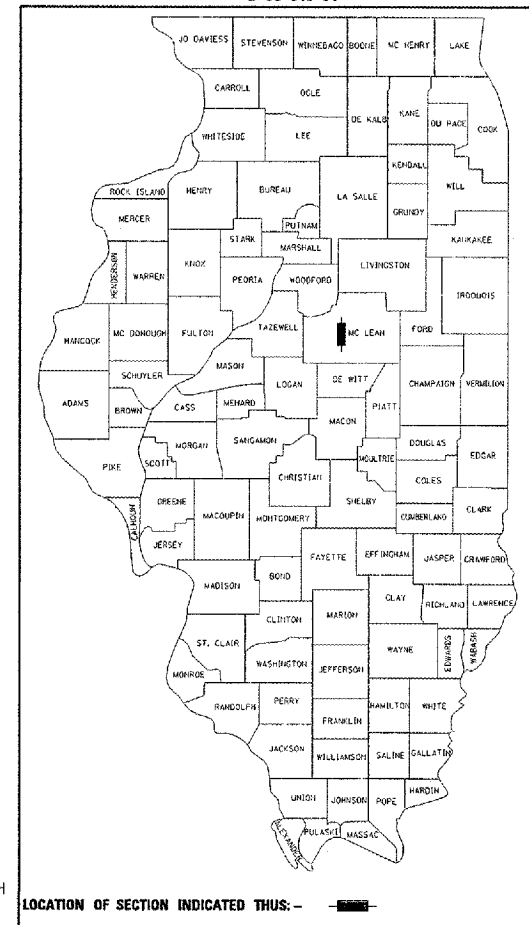

DESIGN DESIGNATION: INTERSTATE 39,900 (2007)
26,000 (2005) PRINCIPAL ARTERIAL CLASS I TRUCK ROUTE
P.U.=75% S.U.=6% M.U.=19%

STATE OF ILLINOIS
DEPARTMENT OF TRANSPORTATION
DIVISION OF HIGHWAYS

SUBMITTED MM 14 20 07
[Signature]
DEPUTY DIRECTOR OF HIGHWAYS, REGION ENGINEER

March 23, 2007
[Signature]
ENGINEER OF DESIGN AND ENVIRONMENT

March 23, 2007
[Signature]
DIRECTOR OF HIGHWAYS, CHIEF ENGINEER

10-11-06
date

JAMES K. CLINARD
LICENSED PROFESSIONAL ENGINEER
NO. 062-041793
STATE OF ILLINOIS

expires 11-30-2007

[Signature]
signature

PROFESSIONAL DESIGN FIRM
LICENSE NO. 184-001717

**PRINTED BY THE AUTHORITY
OF THE STATE OF ILLINOIS**

F.A.I. RTE.	SECTION	COUNTY	TOTAL SHEETS	SHEET NO.
55		McLEAN	87	2
STA.		TO STA.		
FED. ROAD DIST. NO.		ILLINOIS FED. AID PROJECT		

• (57-4)RS-3 & 1

GENERAL NOTES

THE THICKNESS OF HMA SHOWN ON THE PLANS IS THE NOMINAL THICKNESS. DEVIATIONS FROM THE NOMINAL THICKNESS WILL BE PERMITTED WHEN SUCH DEVIATIONS OCCUR DUE TO IRREGULARITIES IN THE EXISTING SURFACE OR BASE ON WHICH THE HMA IS PLACED.

EXCEPT AS NOTED ON THE PLANS, PAVEMENT GRADES SHOWN ARE AT THE TOP OF PAVEMENT SURFACES.

BEFORE ORDERING PIPE CULVERTS OR PIPE DRAINS, THE CONTRACTOR SHALL CONSULT THE ENGINEER FOR EXACT LENGTHS.

THE ENGINEER WILL BE THE SOLE JUDGE CONCERNING CURING TIME FOR THE VARIOUS HMA LIFTS.

FOR STABILIZATION, ALL TYPE III BARRICADES SHALL REQUIRE A MINIMUM OF FOUR SAND BAGS PER BARRICADE.

SEEDING SHALL NOT BE PERMITTED AT ANY TIME WHEN THE GROUND IS FROZEN, WET, OR IN AN UNTILLABLE CONDITION. LOCATIONS TO BE SEEDED WILL BE DETERMINED BY THE ENGINEER.

SHORT TERM PAVEMENT MARKING SHALL BE USED TO OUTLINE EXIT AND ENTRANCE RAMPS FOR THE PRIME COAT APPLICATION AND EACH RESURFACING LIFT.

ON EXISTING PAVEMENT WHICH MAY BE SUPERELEVATED, THE NEW HMA PAVEMENT SHALL BE BUILT WITH THE SAME SUPERELEVATION UNLESS NEW SUPERELEVATION RATES ARE GIVEN ON THE PLANS.

ANY REFERENCE TO A STANDARD IN THESE PLANS SHALL BE INTERPRETED TO MEAN THE EDITION AS INDICATED BY THE SUBNUMBER SHOWN IN THE LIST OF STANDARDS INCLUDED IN THESE PLANS.

THE FOLLOWING RATES OF APPLICATION HAVE BEEN USED IN CALCULATING PLAN QUANTITIES:

GRANULAR MATERIALS	2.43	M TONS / CU M
BITUMINOUS MAT PRIME COAT	0.35	LITERS / SQ M OR
	1.7	LITERS / SQ M
AGGREGATE PRIME COAT	0.002	M TONS / SQ M
HMA RESURFACING	59.8	Kg / SQ M / 25 mm
SHORT TERM PAVEMENT MARKING	10	M / 100 M OF APPLICATION
MIX FOR CRACKS, JTS & FLGWYS	0.0003	M TONS / SQ M
LEVEL BINDER (HAND METHOD)	0.0005	M TONS / SQ M
SUPPLEMENTAL WATERING	15	LITERS / SQ M / APPLICATION
CALCIUM CHLORIDE	1	Kg / SQ M / APPLICATION
TEMPORARY DITCH CHECKS	5	M TONS AGGREGATE

THE CONTRACTOR'S ATTENTION IS DIRECTED TO THE PRESENCE OF DEPARTMENT-OWNED UNDERGROUND ELECTRICAL CABLE WITHIN THE LIMITS OF THE PROPOSED IMPROVEMENT. THE CONTRACTOR SHALL REQUEST THE ILLINOIS DEPARTMENT OF TRANSPORTATION IN OTTAWA (815-434-8417) TO LOCATE THE UNDERGROUND FACILITIES, PROVIDING A MINIMUM OF 72 HOURS NOTICE. THE DEPARTMENT IS NOT A MEMBER OF THE JOINT UTILITY LOCATING INFORMATION FOR EXCAVATORS (JULIE) SYSTEM.

ALL DAMAGE TO DEPARTMENT OWNED UNDERGROUND FACILITIES, CAUSED BY THE CONTRACTOR SHALL BE REPAIRED TO THE SATISFACTION OF THE DEPARTMENT AT THE CONTRACTOR'S EXPENSE. THIS SHALL INCLUDE ALL TEMPORARY REPAIRS REQUIRED TO KEEP THE FACILITY OPERATIONAL WHILE MATERIAL IS BEING OBTAINED TO MAKE PERMANENT REPAIRS. SPLICING OF ELECTRIC CABLE SHALL NOT BE ALLOWED. ELECTRIC CABLE SHALL BE REPLACED FROM POLE TO POLE OR CONTROLLER.

G.N. -442B
THE PATCHING SCHEDULES INCLUDED IN THE PLANS REPRESENT THE BEST INFORMATION AVAILABLE AT THE TIME OF COMPLETION OF THE PLANS FOR LETTING. VARIATIONS IN LOCATION AND SIZES OF BOTH FULL-DEPTH AND PARTIAL-DEPTH PATCHES MAY OCCUR.

G.N. -1004.01
COARSE AGGREGATE GRADATION CA-10 MAY BE USED WHENEVER COARSE AGGREGATE CA-6 IS SPECIFIED IN THE STANDARD SPECIFICATIONS.

ALL MATERIAL PLACED AS HOT-MIX ASPHALT SHOULDERS SHALL BE COMPACTED TO 94.0-98.4 PERCENT OF THE MAXIMUM THEORETICAL DENSITY. THIS REQUIREMENT SHALL APPLY TO BOTH B.A.M. AND IL 9.5L GRADATION SHOULDER MIXES. THIS MAXIMUM DENSITY SHALL BE DETERMINED FROM THE MOVING AVERAGE OF FOUR TESTS AS IN OTHER OC/OA TESTING. A NUCLEAR GAUGE DENSITY/CORE CORRELATION SHALL BE PERFORMED FOR BOTH THE B.A.M. AND IL 9.5L MIXES USING STANDARD CORRELATION PROCEDURES.

G.N.-406H
MIXTURE REQUIREMENTS

THE FOLLOWING MIXTURE REQUIREMENTS ARE APPLICABLE FOR THIS PROJECT:

MIXTURE DESIGN	HOT-MIX ASPHALT POLYMER BINDER	HOT-MIX ASPHALT POLYMER SURFACE	HOT-MIX ASPHALT POLYMER SURFACE ON BRIDGES	HOT-MIX ASPHALT SHOULDERS BOTTOM LIFT REPAIR AREAS	HOT-MIX ASPHALT SHOULDERS TOP LIFT
PG GRADE	SBS PG 70-22	SBS PG 70-22	SBS PG 70-22	PG 58-22	PG 58-22
MAX % RAP ALLOWABLE *	10%	10%	10%	30%	30%
DESIGN AIR VOIDS	4.0% @ N 105	4.0% @ N 105	4.0% @ N 105	2.0% @ N 30	3.0% @ N 30
MIXTURE COMPOSITION	IL 19.0	IL 9.5	IL 9.5	BAM	IL 9.5L
FRICITION AGGREGATE	N/A	MIXTURE E	MIXTURE E	N/A	MIXTURE C
DENSITY CONTROL METHOD	CORRELATED	CORRELATED	UNCORRELATED	UNCORRELATED	CORRELATED

* IF RAP OPTION IS SELECTED, THE ASPHALT CEMENT GRADE MAY NEED TO BE ADJUSTED. THIS WILL BE DETERMINED BY THE ENGINEER.

F.A.I. RTE.	SECTION	COUNTY	TOTAL SHEETS	SHEET NO.
55	*	McLEAN	87	3
STA.	TO STA.			
FED. ROAD DIST. NO.	ILLINOIS FED. AID PROJECT			

SUMMARY OF QUANTITIES

← 90% FED. 10% STATE →

CODE NO	ITEM	UNIT	CONSTRUCTION TYPE CODE:		SFTY 2A				
			URBAN TOTAL QUANTITY	I000	STA. 36+305 TO STA. 40+486 ROADWAY	SN 057-0024 & SN 057-0025	SN 057-0026 & SN 057-0027	SN 057-0028 & SN 057-0029	SN 057-0214 & SN 057-0215
	FUNDING: URBAN 90% FEDERAL, 10% STATE								
MX033726	POLYURETHANE MATERIAL	CU M	3.0	3.0					
* M7802070	POLYUREA PAVEMENT MARKING TYPE II - LINE100MM	METER	14,817.0	14,817.0					
* M7802080	POLYUREA PAVEMENT MARKING TYPE II - LINE200MM	METER	547.0	547.0					
* M7802090	POLYUREA PAVEMENT MARKING TYPE II - LINE300MM	METER	487.0	487.0					
2 M6420017	SHOULDER RUMBLE STRIP SPECIAL	METER	10,858.0	10,858.0					
28000500	INLET AND PIPE PROTECTION	EACH	3.0	3.0					
50500505	STUD SHEAR CONNECTORS	EACH	4,662.0		2,646.0	2,016.0			
50500715	JACK AND REMOVE EXISTING BEARINGS	EACH	48.0			48.0			
50800515	BAR SPLICERS	EACH	384.0		198.0	186.0			
52100010	ELASTOMERIC BEARING ASSEMBLY, TYPE I	EACH	24.0			24.0			
52100020	ELASTOMERIC BEARING ASSEMBLY, TYPE II	EACH	24.0			24.0			
* 63100085	TRAFFIC BARRIER TERMINAL, TYPE 6	EACH	10.0	10.0					
* 63100087	TRAFFIC BARRIER TERMINAL, TYPE 6A	EACH	2.0	2.0					
* 63100167	TRAFFIC BARRIER TERMINAL TYPE 1, SPECIAL (TANGENT)	EACH	13.0	13.0					
63304385	TRAFFIC BARRIER TERMINAL REMOVAL, TYPE 1	EACH	7.0	7.0					
63304705	TRAFFIC BARRIER TERMINAL REMOVAL, TYPE 5A	EACH	2.0	2.0					
63304805	TRAFFIC BARRIER TERMINAL REMOVAL, TYPE 6	EACH	4.0	4.0					
67100100	MOBILIZATION	L SUM	1.0	1.0					
70100207	TRAFFIC CONTROL AND PROTECTION, STANDARD 701402	EACH	5.0	5.0					
70100420	TRAFFIC CONTROL AND PROTECTION, STANDARD 701411	EACH	6.0	6.0					
70100700	TRAFFIC CONTROL AND PROTECTION, STANDARD 701406	L SUM	1.0	1.0					
70100800	TRAFFIC CONTROL AND PROTECTION, STANDARD 701401	L SUM	1.0	1.0					
70102550	TRAFFIC CONTROL AND PROTECTION FOR TEMPORARY DETOUR	EACH	1.0	1.0					
70102630	TRAFFIC CONTROL AND PROTECTION, STANDARD 701601	L SUM	1.0	1.0					
70103815	TRAFFIC CONTROL SURVEILLANCE	CAL DA	20.0	20.0					
70106800	CHANGEABLE MESSAGE SIGN	CAL MO	20.0	20.0					
* 78100100	RAISED REFLECTIVE PAVEMENT MARKER	EACH	768.0	768.0					
* 78100105	RAISED REFLECTIVE PAVEMENT MARKER (BRIDGE)	EACH	26.0	26.0					
* 78200405	GUARDRAIL MARKERS	EACH	40.0	40.0					
* 78201000	TERMINAL MARKER - DIRECT APPLIED	EACH	13.0	13.0					
78300200	RAISED REFLECTIVE PAVEMENT MARKER REMOVAL	EACH	753.0	753.0					
M2113100	TOPSOIL FURNISH AND PLACE, 100MM	SQ M	33.0	33.0					
M2140100	GRADING AND SHAPING DITCHES	METER	461.0	461.0					
* M2500210	SEEDING, CLASS 2A	HA	0.1	0.1					
* M2500400	NITROGEN FERTILIZER NUTRIENT	KG	10.0	10.0					
* M2500500	PHOSPHORUS FERTILIZER NUTRIENT	KG	10.0	10.0					

* 157-4IRS-3 & 1

* SPECIALTY ITEMS
2 I000 100% STATE

SUMMARY OF QUANTITIES
F.A.I. 55
SECTION (57-4)RS-3 & 1
MCLEAN COUNTY

F.A.I. RTE.	SECTION	COUNTY	TOTAL SHEETS	SHEET NO.
55		McLEAN	87	4
STA.	TO STA.			
FED. ROAD DIST. NO.	ILLINOIS FED. AID PROJECT			

SUMMARY OF QUANTITIES

90% FED.
10% STATE.

CODE NO	ITEM	UNIT	CONSTRUCTION TYPE CODE:		SFTY 2A				
			URBAN TOTAL QUANTITY	I000	STA. 36+305 TO STA. 40+486 ROADWAY	SN 057-0024 & SN 057-0025	SN 057-0026 & SN 057-0027	SN 057-0028 & SN 057-0029	SN 057-0214 & SN 057-0215
	FUNDING: URBAN 90% FEDERAL, 10% STATE								
M2500600	POTASSIUM FERTILIZER NUTRIENT	KG	10.0	10.0					
M2510630	EROSION CONTROL BLANKET	SQ M	33.0	33.0					
M2810105	STONE RIPRAP, CLASS A3	SQ M	754.0	748.0			6.0		
M2810207	STONE RIPRAP, CLASS A4	M TON	8.1	8.1					
M2810707	STONE DUMPED RIPRAP, CLASS A4	SQ M	23.0					23.0	
M2850100	FABRIC FORMED CONCRETE REVETMENT MAT	SQ M	360.0	360.0					
M4060100	BITUMINOUS MATERIALS (PRIME COAT)	LITER	23,637.0	23,637.0					
M4060400	MIXTURE FOR CRACKS, JOINTS, AND FLANGEWAYS	M TON	100.0	100.0					
M4060895	CONSTRUCTING TEST STRIP	EACH	2.0	2.0					
M4060990	TEMPORARY RAMP	SQ M	141.0	141.0					
M4063245	POLYMERIZED HOT-MIX ASPHALT BINDER COURSE, IL-19.0, N105	M TON	3,389.0	3,389.0					
M4063575	POLYMERIZED HOT-MIX ASPHALT SURFACE COURSE, MIX "E", N105	M TON	6,139.0	6,064.0			75.0		
M4080500	INCIDENTAL HOT-MIX ASPHALT SURFACING	M TON	50.0	50.0					
M4400735	HOT-MIX ASPHALT SURFACE REMOVAL, 35MM	SQ M	37,332.0	37,332.0					
M4400810	HOT-MIX ASPHALT SURFACE REMOVAL, 110MM	SQ M	13,128.0	13,128.0					
M4400950	HOT-MIX ASPHALT SURFACE REMOVAL, VARIABLE DEPTH	SQ M	844.0	844.0					
M4402115	HOT-MIX ASPHALT SURFACE REMOVAL, DECK	SQ M	815.0				815.0		
M4405000	PAVED DITCH REMOVAL	METER	108.0	108.0					
M4422350	PAVEMENT PATCHING, TYPE II 350MM	SQ M	471.0	471.0					
M4424350	PAVEMENT PATCHING, TYPE IV 350MM	SQ M	980.0	980.0					
M4812000	AGGREGATE SHOULDERS, TYPE B	M TON	992.0	992.0					
M4820400	HOT-MIX ASPHALT SHOULDERS	M TON	1,112.0	1,112.0					
M5010240	CONCRETE REMOVAL	CU M	215.0		121.4	93.6			
M5010465	SLOPE WALL REMOVAL	SQ M	40.0		39.0		1.0		
M5010570	PROTECTIVE SHIELD	SQ M	1,068.0		604.0	464.0			
M5030360	CONCRETE SUPERSTRUCTURE	CU M	215.0		121.4	93.6			
M5030390	BRIDGE DECK GROOVING	SQ M	764.0		432.0	332.0			
M5030450	PROTECTIVE COAT	SQ M	943.0		537.0	406.0			
M5050405	FURNISHING AND ERECTING STRUCTURAL STEEL	KG	3,730.0			3,730.0			
M5080205	REINFORCEMENT BARS, EPOXY COATED	KG	29,820		16,950.0	12,870.0			
M5110100	SLOPE WALL 100 MM	SQ M	40.0		39.0		1.0		
M5200225	PREFORMED JOINT STRIP SEAL	METER	199.5		112.2	87.3			
M5810200	WATERPROOFING MEMBRANE SYSTEM	SQ M	815.0				815.0		
M6063400	PAVED DITCH, TYPE B-15	METER	26.0	26.0					

• SPECIALTY ITEMS

2 I000 100% STATE

SUMMARY OF QUANTITIES
F.A.I. 55
SECTION (57-4)RS-3 & I
MCLEAN COUNTY

F.A.I. RTE.	SECTION	COUNTY	TOTAL SHEETS	SHEET NO.
55		MCLEAN	87	5
STA.		TO STA.		
FED. ROAD DIST. NO.		ILLINOIS	FED. AID PROJECT	

90% FED.
10% STATE

SUMMARY OF QUANTITIES

CODE NO	ITEM	UNIT	CONSTRUCTION TYPE CODE:		SFTY 2A				
			URBAN TOTAL QUANTITY	I000	STA. 36+305 TO STA. 40+486 ROADWAY	SN 057-0024 & SN 057-0025	SN 057-0026 & SN 057-0027	SN 057-0028 & SN 057-0029	SN 057-0214 & SN 057-0215
	FUNDING: URBAN 90% FEDERAL, 10% STATE								
M6063440	PAVED DITCH, TYPE B-45	METER	82.0	82.0					
• M6300100	STEEL PLATE BEAM GUARD RAIL, TYPE A	METER	464.82	464.82					
• M6320030	GUARDRAIL REMOVAL	METER	445.0	445.0					
M6650100	WOVEN WIRE FENCE, 1.2 METER	METER	32.0	32.0					
M7030100	SHORT-TERM PAVEMENT MARKING	METER	2,305.0	2,305.0					
M7030220	TEMPORARY PAVEMENT MARKING - LINE 100 MM	METER	15,964.0	15,964.0					
M7031000	WORK ZONE PAVEMENT MARKING REMOVAL	SO M	115.0	115.0					
M7040100	TEMPORARY CONCRETE BARRIER	METER	1,415.2	1,415.2					
M7040200	RELOCATE TEMPORARY CONCRETE BARRIER	METER	1,747.0	1,747.0					
M7800355	PREFORMED PLASTIC PAVEMENT MARKING, TYPE B - INLAID - LINE 100MM	METER	2,091.0	2,091.0					
M7830100	PAVEMENT MARKING REMOVAL	SO M	1,640.0	1,640.0					
MX030069	SILICONE JOINT SEALER	METER	116.1		62.8		53.3		
MX032584	MATERIAL TRANSFER DEVICE	M TON	9,454.0	9,454.0					
MX033693	STRUCTURAL REPAIR OF CONCRETE (DEPTH GREATER THAN 125 MM)	SO M	1.0		1.0				
MX033694	STRUCTURAL REPAIR OF CONCRETE (DEPTH EQUAL TO OR LESS THAN 125 MM)	SO M	14.0		1.2	1.0	0.4	11.4	
MZ016200	DECK SLAB REPAIR (PARTIAL)	SO M	96.0				96.0		
X0301894	REMOVE AND REINSTALL CONCRETE HEADWALL FOR PIPE UNDERDRAIN	EACH	3.0	3.0					
X0321468	PLUG EXISTING DECK DRAINS	EACH	16.0				16.0		
Z0010615	CLEANING EXISTING INLETS	EACH	5.0	5.0					
• Z0029999	IMPACT ATTENUATOR REMOVAL	EACH	14.0	14.0					
• Z0030150	IMPACT ATTENUATORS (NON-REDIRECTIVE), TEST LEVEL 3	EACH	14.0	14.0					
• Z0030250	IMPACT ATTENUATORS, TEMPORARY (NON-REDIRECTIVE), TEST LEVEL 3	EACH	3.0	3.0					
• Z0030350	IMPACT ATTENUATORS, RELOCATE (NON-REDIRECTIVE), TEST LEVEL 3	EACH	2.0	2.0					

* (57-4)RS-3 & 1

• SPECIALTY ITEMS
2 I000 100% STATE

SUMMARY OF QUANTITIES
F.A.I. 55
SECTION (57-4)RS-3 & I
MCLEAN COUNTY

F.A. RTE.	SECTION	COUNTY	TOTAL SHEETS	SHEET NO.
55	•	MCCLEAN	87	6
STA.		TO STA.		
FED. ROAD DIST. NO.		ILLINOIS FED. AID PROJECT		
• (57-4)RS-3 & I				

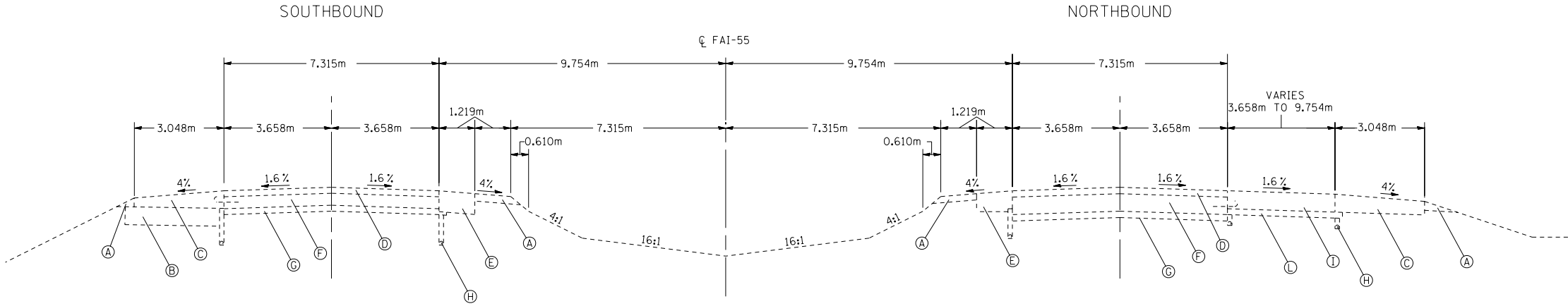

TYPICAL SECTION
STA. 36+500 TO STA. 36+630.189 N.B. & S.B.

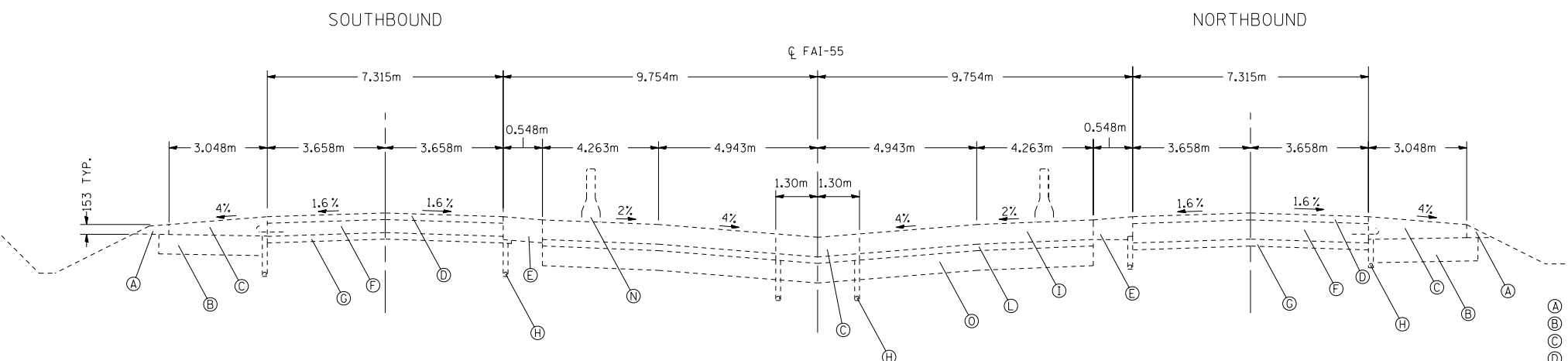

TYPICAL SECTION
STA. 36+305 TO STA. 36+500 N.B. & S.B.

- (A) AGGREGATE SHOULDER, TYPE B
 - (B) LIME MODIFIED SOIL, 305 mm
 - (C) P.C.C. SHOULDERS, 305 mm
 - (D) HOT MIX ASPHALT OVERLAY, 108 mm & VARIES
 - (E) HOT MIX ASPHALT SHOULDERS
 - (F) P.C.C. PAVEMENT, 254 mm
 - (G) SUB-BASE GRANULAR MATERIAL, 153 mm
 - (H) SUB-SURFACE DRAINAGE SYSTEM
 - (I) P.C.C. PAVEMENT, 305 mm
 - (J) P.C.C. SHOULDER, 273 mm
 - (K) P.C.C. PAVEMENT, 273 mm
 - (L) STABILIZED SUB-BASE, 102 mm
 - (M) P.C.C. APPROACH SLAB, 305 mm
 - (N) DOUBLE FACED CONCRETE BARRIER
 - (O) POROUS GRANULAR EMBANKMENT, SUBGRADE 300 mm
- EXISTING TYPICAL SECTIONS
FAI 55 (I-55)
SECTION (57-4)RS-3 & I
MCCLEAN COUNTY

F.A. RTE.	SECTION	COUNTY	TOTAL SHEETS	SHEET NO.
55	•	MCCLEAN	87	7
STA.		TO STA.		
FED. ROAD DIST. NO.		ILLINOIS FED. AID PROJECT		
• (57-4)RS-3 & I				

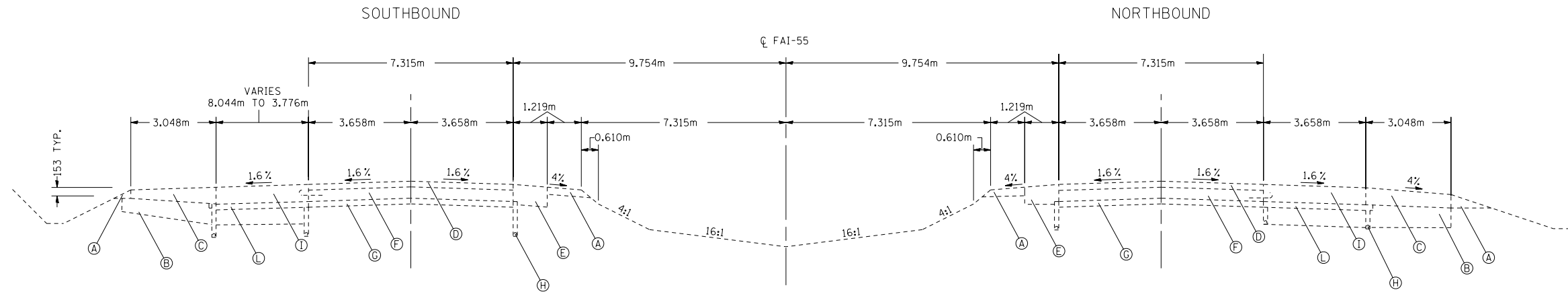

TYPICAL SECTION
 STA. 36+803.794 TO STA. 37+084.421 N.B.
 STA. 36+803.794 TO STA. 37+017.154 S.B.

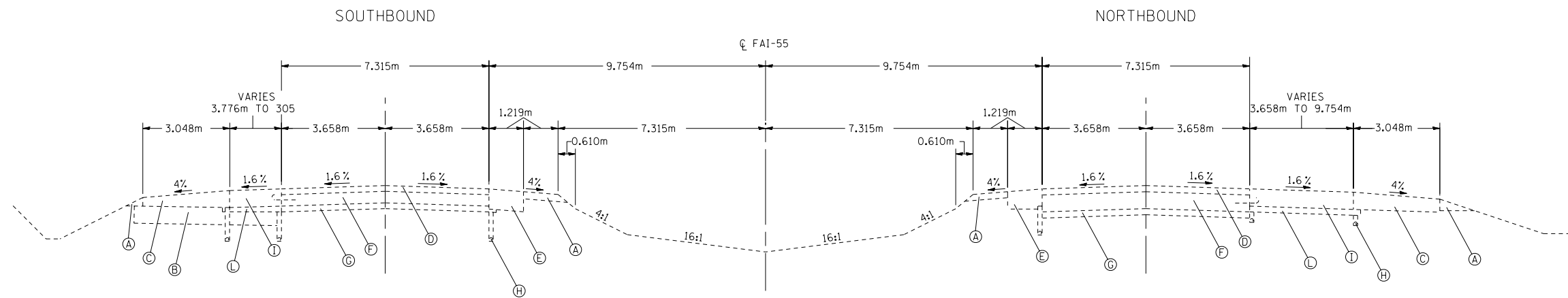

TYPICAL SECTION
 STA. 36+630.189 TO STA. 36+803.794 N.B. & S.B.

- (A) AGGREGATE SHOULDER, TYPE B
- (B) LIME MODIFIED SOIL, 305 mm
- (C) P.C.C. SHOULDERS, 305 mm
- (D) HOT MIX ASPHALT OVERLAY, 108 mm & VARIES
- (E) HOT MIX ASPHALT SHOULDERS
- (F) P.C.C. PAVEMENT, 254 mm
- (G) SUB-BASE GRANULAR MATERIAL, 153 mm
- (H) SUB-SURFACE DRAINAGE SYSTEM
- (I) P.C.C. PAVEMENT, 305 mm
- (J) P.C.C. SHOULDER, 273 mm
- (K) P.C.C. PAVEMENT, 273 mm
- (L) STABILIZED SUB-BASE, 102 mm
- (M) P.C.C. APPROACH SLAB, 305 mm
- (N) DOUBLE FACED CONCRETE BARRIER
- (O) POROUS GRANULAR EMBANKMENT, SUBGRADE 300 mm

EXISTING TYPICAL SECTIONS
 FAI 55 (I-55)
 SECTION (57-4)RS-3 & I
 MCCLEAN COUNTY

F.A. RTE.	SECTION	COUNTY	TOTAL SHEETS	SHEET NO.
55	•	McCLEAN	87	8
STA. TO STA.		ILLINOIS FED. AID PROJECT		
FED. ROAD DIST. NO.		• (57-4)RS-3 & I		

•• VARIES 3.048m TO 1.829m
STA. 37+407.430 TO STA. 37+370.823

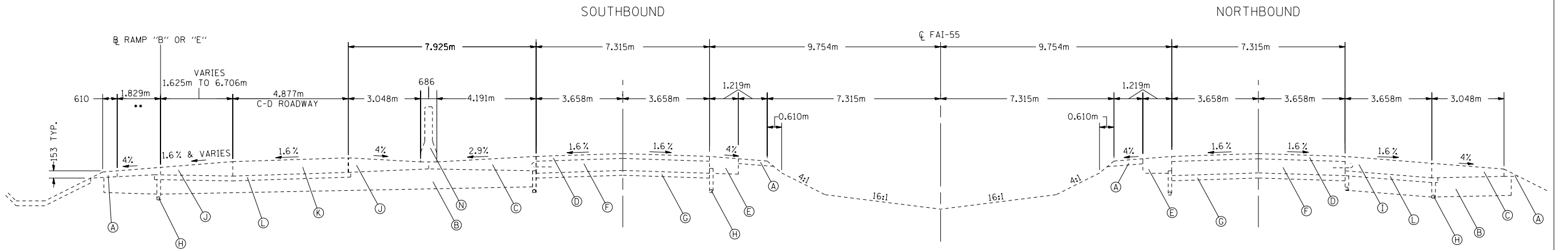

TYPICAL SECTION
STA. 37+231.545 TO STA. 37+412.956 N.B.
STA. 37+255.030 TO STA. 37+410.902 S.B.

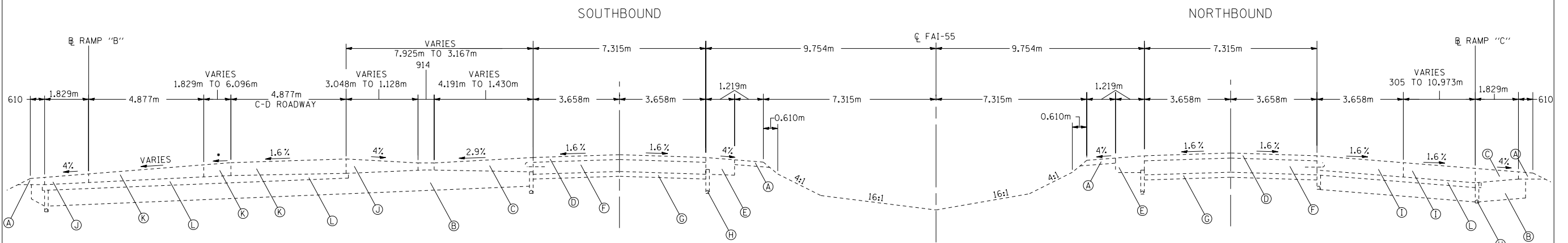

TYPICAL SECTION
STA. 37+084.421 TO STA. 37+231.545 N.B.
STA. 37+017.154 TO STA. 37+255.030 S.B.

- (A) AGGREGATE SHOULDER, TYPE B
- (B) LIME MODIFIED SOIL, 305 mm
- (C) P.C.C. SHOULDERS, 305 mm
- (D) HOT MIX ASPHALT OVERLAY, 108 mm & VARIES
- (E) HOT MIX ASPHALT SHOULDERS
- (F) P.C.C. PAVEMENT, 254 mm
- (G) SUB-BASE GRANULAR MATERIAL, 153 mm
- (H) SUB-SURFACE DRAINAGE SYSTEM
- (I) P.C.C. PAVEMENT, 305 mm
- (J) P.C.C. SHOULDER, 273 mm
- (K) P.C.C. PAVEMENT, 273 mm
- (L) STABILIZED SUB-BASE, 102 mm
- (M) P.C.C. APPROACH SLAB, 305 mm
- (N) DOUBLE FACED CONCRETE BARRIER
- (O) POROUS GRANULAR EMBANKMENT, SUBGRADE 300 mm

EXISTING TYPICAL SECTIONS
FAI 55 (I-55)
SECTION (57-4)RS-3 & I
McCLEAN COUNTY

F.A. RTE.	SECTION	COUNTY	TOTAL SHEETS	SHEET NO.
55		McCLEAN	87	9
STA.		TO STA.		
FED. ROAD DIST. NO.		ILLINOIS FED. AID PROJECT		
• (57-4)RS-3 & I				

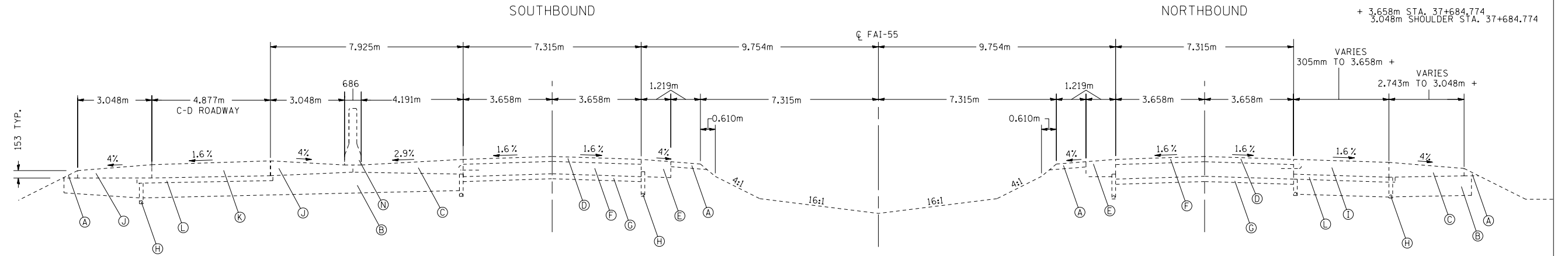

TYPICAL SECTION
 STA. 37+643.215 TO STA. 37+852.415 N.B.
 STA. 37+618.172 TO STA. 37+855.100 S.B.

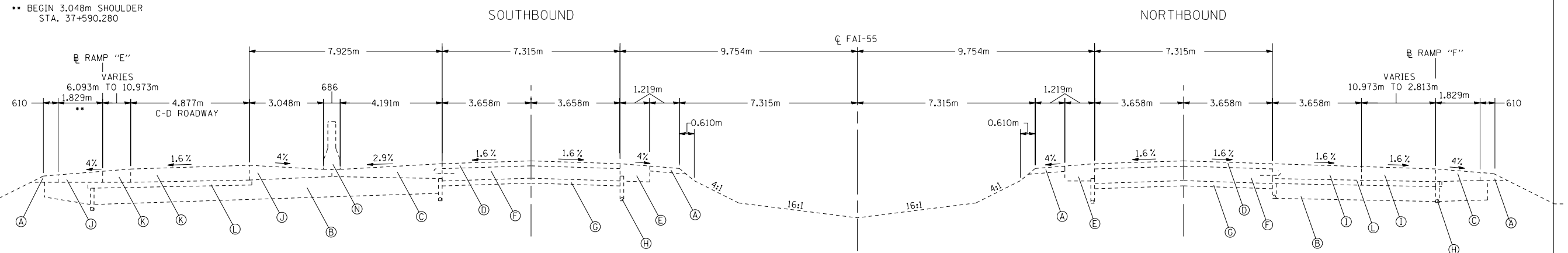

TYPICAL SECTION
 STA. 37+537.555 TO STA. 37+643.215 N.B.
 STA. 37+535.440 TO STA. 37+618.172 S.B.

- (A) AGGREGATE SHOULDER, TYPE B
- (B) LIME MODIFIED SOIL, 305 mm
- (C) P.C.C. SHOULDERS, 305 mm
- (D) HOT MIX ASPHALT OVERLAY, 108 mm & VARIES
- (E) HOT MIX ASPHALT SHOULDERS
- (F) P.C.C. PAVEMENT, 254 mm
- (G) SUB-BASE GRANULAR MATERIAL, 153 mm
- (H) SUB-SURFACE DRAINAGE SYSTEM
- (I) P.C.C. PAVEMENT, 305 mm
- (J) P.C.C. SHOULDER, 273 mm
- (K) P.C.C. PAVEMENT, 273 mm
- (L) STABILIZED SUB-BASE, 102 mm
- (M) P.C.C. APPROACH SLAB, 305 mm
- (N) DOUBLE FACED CONCRETE BARRIER
- (O) POROUS GRANULAR EMBANKMENT, SUBGRADE 300 mm

EXISTING TYPICAL SECTIONS
 FAI 55 (I-55)
 SECTION (57-4)RS-3 & I
 McCLEAN COUNTY

•• BEGIN 3.048m SHOULDER
 STA. 37+590.280

F.A. RTE.	SECTION	COUNTY	TOTAL SHEETS	SHEET NO.
55	•	McCLEAN	87	10
STA.		TO STA.		
FED. ROAD DIST. NO.		ILLINOIS FED. AID PROJECT		
• (57-4)RS-3 & I				

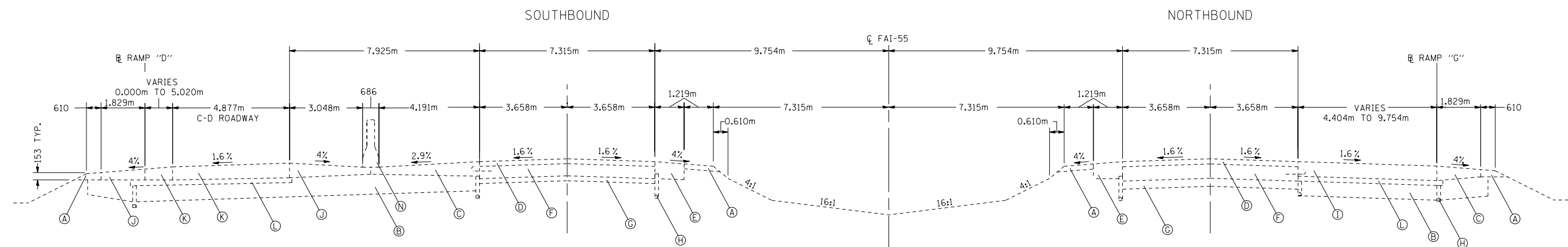

TYPICAL SECTION
STA. 37+966.007 TO 38+116.652 N.B. & S.B.

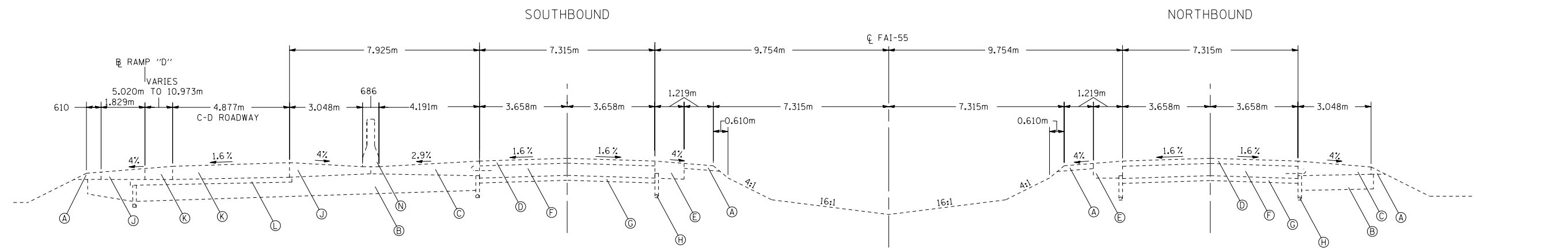

TYPICAL SECTION
STA. 37+852.415 TO STA. 37+966.007 N.B.
STA. 37+855.100 TO STA. 37+966.007 S.B.

- (A) AGGREGATE SHOULDER, TYPE B
- (B) LIME MODIFIED SOIL, 305 mm
- (C) P.C.C. SHOULDERS, 305 mm
- (D) HOT MIX ASPHALT OVERLAY, 108 mm & VARIES
- (E) HOT MIX ASPHALT SHOULDERS
- (F) P.C.C. PAVEMENT, 254 mm
- (G) SUB-BASE GRANULAR MATERIAL, 153 mm
- (H) SUB-SURFACE DRAINAGE SYSTEM
- (I) P.C.C. PAVEMENT, 305 mm
- (J) P.C.C. SHOULDER, 273 mm
- (K) P.C.C. PAVEMENT, 273 mm
- (L) STABILIZED SUB-BASE, 102 mm
- (M) P.C.C. APPROACH SLAB, 305 mm
- (N) DOUBLE FACED CONCRETE BARRIER
- (O) POROUS GRANULAR EMBANKMENT, SUBGRADE 300 mm

EXISTING TYPICAL SECTIONS
FAI 55 (I-55)
SECTION (57-4)RS-3 & I
McCLEAN COUNTY

F.A. RTE.	SECTION	COUNTY	TOTAL SHEETS	SHEET NO.
55	•	MCCLEAN	87	11
STA.		TO STA.		
FED. ROAD DIST. NO.	ILLINOIS FED. AID PROJECT			

• (57-4)RS-3 & I

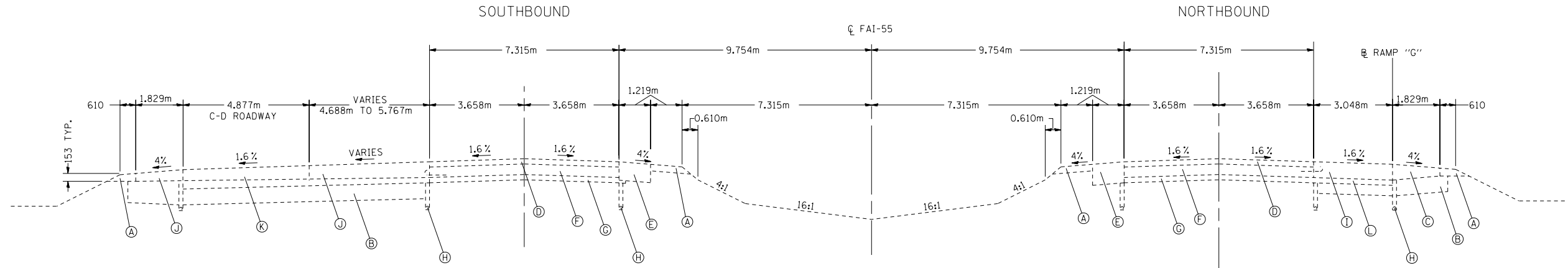

TYPICAL SECTION
 STA. 38+177.850 TO STA. 38+210.808 N.B.
 STA. 38+177.850 TO STA. 38+208.330 S.B.

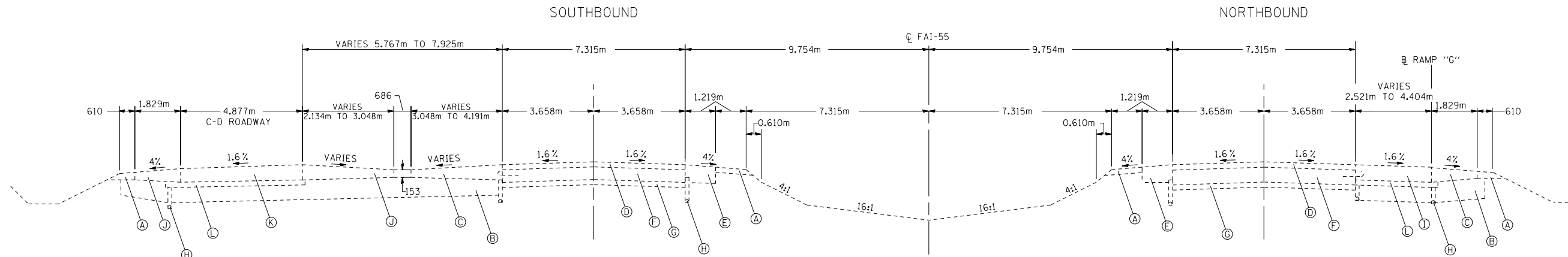

TYPICAL SECTION
 STA. 38+116.652 TO STA. 38+177.850 N.B. & S.B.

- (A) AGGREGATE SHOULDER, TYPE B
- (B) LIME MODIFIED SOIL, 305 mm
- (C) P.C.C. SHOULDERS, 305 mm
- (D) HOT MIX ASPHALT OVERLAY, 108 mm & VARIES
- (E) HOT MIX ASPHALT SHOULDERS
- (F) P.C.C. PAVEMENT, 254 mm
- (G) SUB-BASE GRANULAR MATERIAL, 153 mm
- (H) SUB-SURFACE DRAINAGE SYSTEM
- (I) P.C.C. PAVEMENT, 305 mm
- (J) P.C.C. SHOULDER, 273 mm
- (K) P.C.C. PAVEMENT, 273 mm
- (L) STABILIZED SUB-BASE, 102 mm
- (M) P.C.C. APPROACH SLAB, 305 mm
- (N) DOUBLE FACED CONCRETE BARRIER
- (O) POROUS GRANULAR EMBANKMENT, SUBGRADE 300 mm

EXISTING TYPICAL SECTIONS
 FAI 55 (I-55)
 SECTION (57-4)RS-3 & I
 MCCLEAN COUNTY

F.A. RTE.	SECTION	COUNTY	TOTAL SHEETS	SHEET NO.
55	•	McCLEAN	87	12
STA.		TO STA.		
FED. ROAD DIST. NO.		ILLINOIS FED. AID PROJECT		
• (57-4)RS-3 & I				

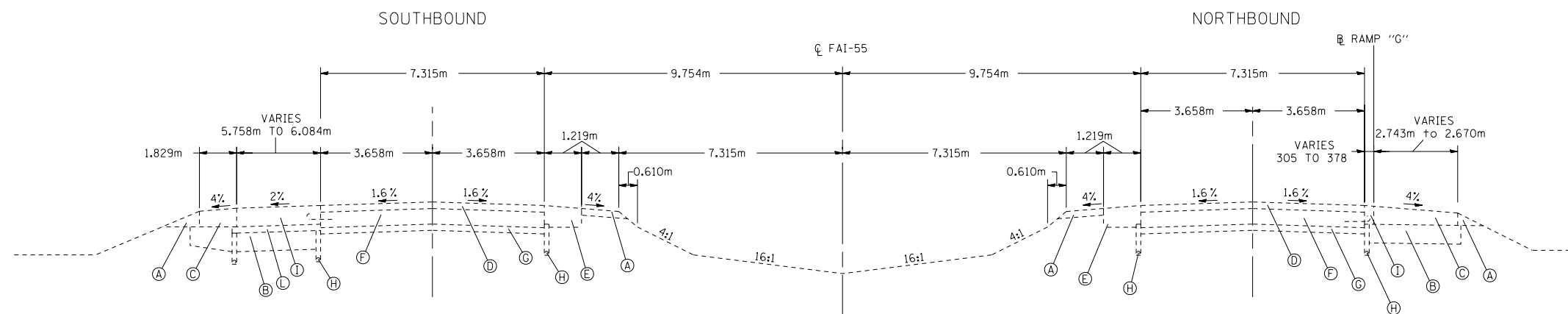

TYPICAL SECTION

STA. 38+317.995 TO STA. 38+321.655 N.B.
 STA. 38+315.520 TO STA. 38+321.655 S.B.

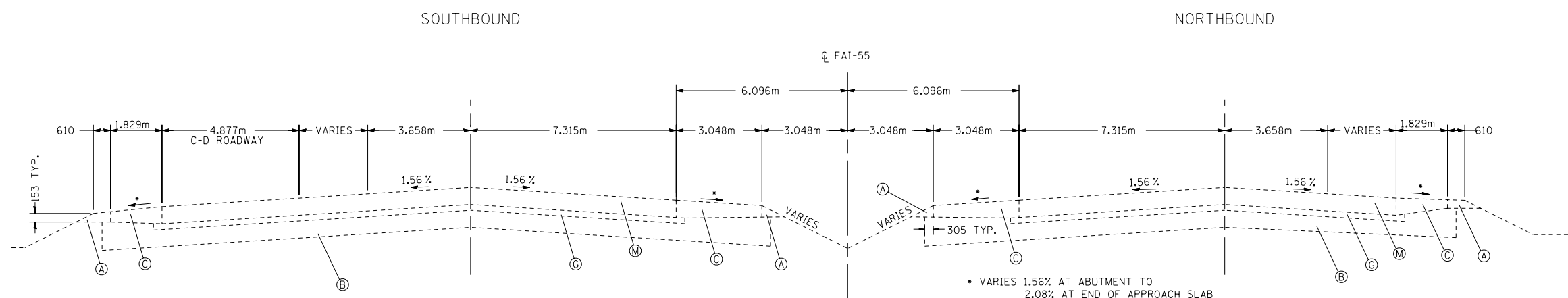

TYPICAL SECTION

STA. 38+210.808 TO STA. 38+241.288 AND STA. 38+287.515 TO STA. 38+317.995 N.B.
 STA. 38+208.333 TO STA. 38+238.813 AND STA. 38+285.040 TO STA. 38+315.520 S.B.

- (A) AGGREGATE SHOULDER, TYPE B
- (B) LIME MODIFIED SOIL, 305 mm
- (C) P.C.C. SHOULDERS, 305 mm
- (D) HOT MIX ASPHALT OVERLAY, 108 mm & VARIES
- (E) HOT MIX ASPHALT SHOULDERS
- (F) P.C.C. PAVEMENT, 254 mm
- (G) SUB-BASE GRANULAR MATERIAL, 153 mm
- (H) SUB-SURFACE DRAINAGE SYSTEM
- (I) P.C.C. PAVEMENT, 305 mm
- (J) P.C.C. SHOULDER, 273 mm
- (K) P.C.C. PAVEMENT, 273 mm
- (L) STABILIZED SUB-BASE, 102 mm
- (M) P.C.C. APPROACH SLAB, 305 mm
- (N) DOUBLE FACED CONCRETE BARRIER
- (O) POROUS GRANULAR EMBANKMENT, SUBGRADE 300 mm

EXISTING TYPICAL SECTIONS
 FAI 55 (I-55)
 SECTION (57-4)RS-3 & I
 McCLEAN COUNTY

F.A. RTE.	SECTION	COUNTY	TOTAL SHEETS	SHEET NO.
55	•	MCCLEAN	87	13
STA.		TO STA.		
FED. ROAD DIST. NO.		ILLINOIS FED. AID PROJECT		
• (57-4)RS-3 & I				

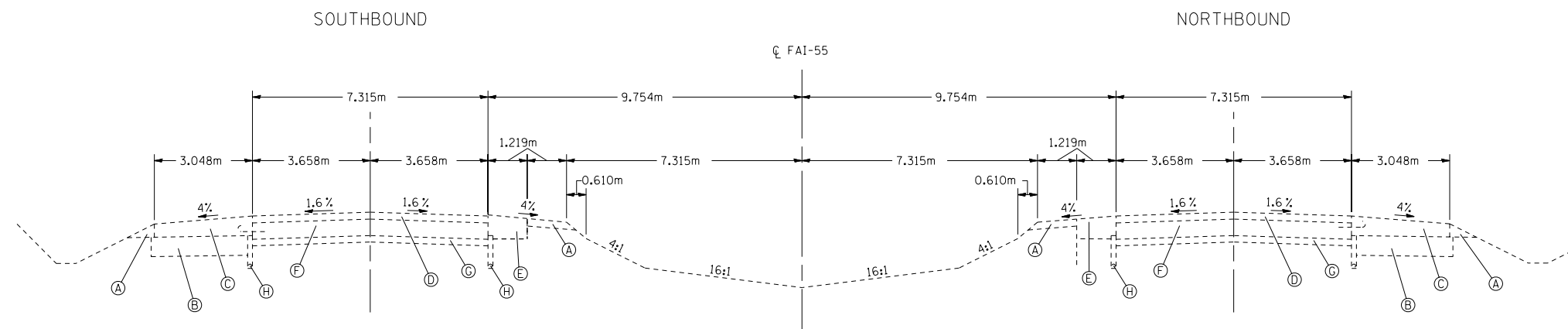

TYPICAL SECTION
STA. 38+424.504 TO STA. 38+480.197 N.B. & S.B.

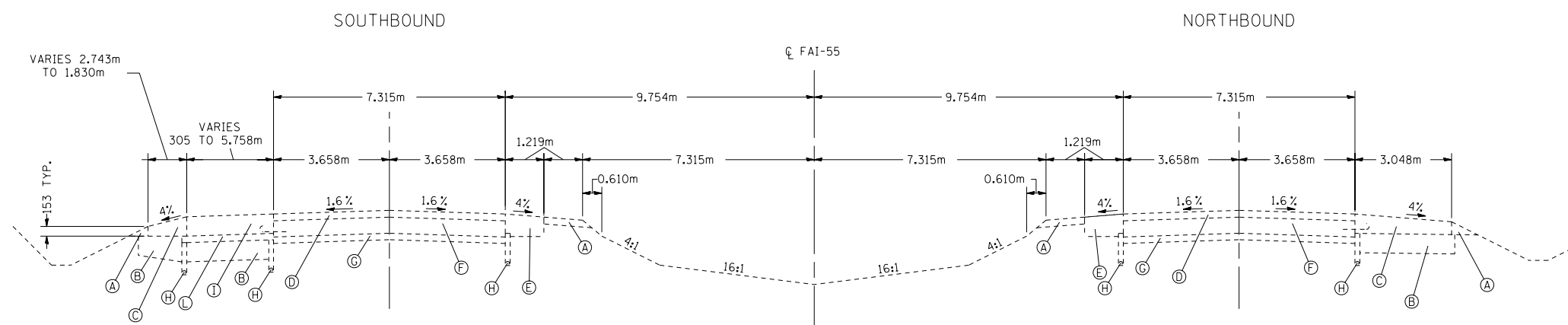

TYPICAL SECTION
STA. 38+321.655 TO STA. 38+424.504 N.B. & S.B.

- (A) AGGREGATE SHOULDER, TYPE B
- (B) LIME MODIFIED SOIL, 305 mm
- (C) P.C.C. SHOULDERS, 305 mm
- (D) HOT MIX ASPHALT OVERLAY, 108 mm & VARIES
- (E) HOT MIX ASPHALT SHOULDERS
- (F) P.C.C. PAVEMENT, 254 mm
- (G) SUB-BASE GRANULAR MATERIAL, 153 mm
- (H) SUB-SURFACE DRAINAGE SYSTEM
- (I) P.C.C. PAVEMENT, 305 mm
- (J) P.C.C. SHOULDER, 273 mm
- (K) P.C.C. PAVEMENT, 273 mm
- (L) STABILIZED SUB-BASE, 102 mm
- (M) P.C.C. APPROACH SLAB, 305 mm
- (N) DOUBLE FACED CONCRETE BARRIER
- (O) POROUS GRANULAR EMBANKMENT, SUBGRADE 300 mm

EXISTING TYPICAL SECTIONS
FAI 55 (I-55)
SECTION (57-4)RS-3 & I
MCCLEAN COUNTY

F.A. RTE.	SECTION	COUNTY	TOTAL SHEETS	SHEET NO.
55	*	McCLEEN	87	14
STA.		TO STA.		
FED. ROAD DIST. NO.		ILLINOIS FED. AID PROJECT		
* (57-4)RS-3 & I				

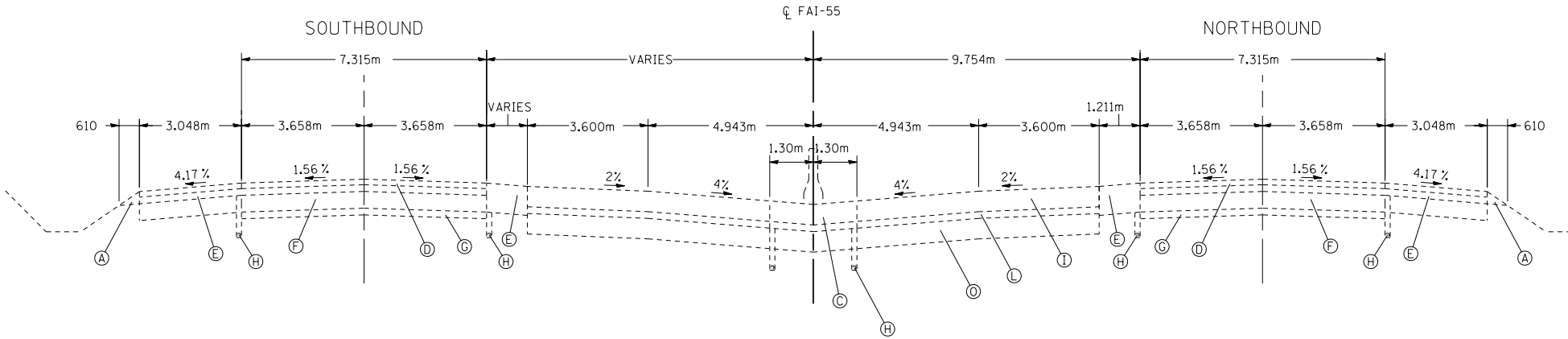

TYPICAL SECTION
 STA. 40+270.000 TO STA. 40+486.00 N.B. & S.B.

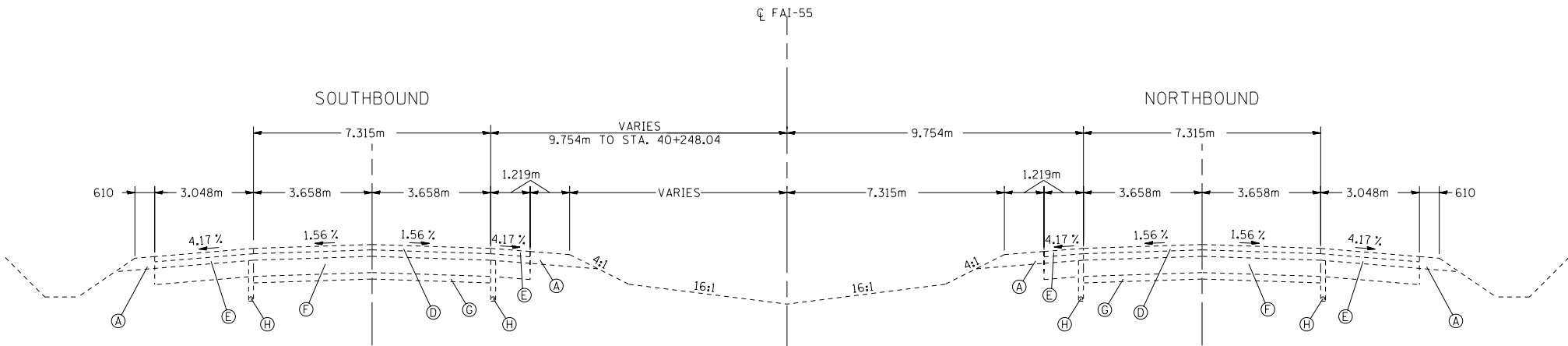

TYPICAL SECTION
 STA. 38+480.197 TO STA. 40+270.000 N.B. & S.B.
 (BRIDGE OMISSION STA. 38+525.439 TO STA. 38+560.482 S.B.)
 STA. 38+526.652 TO STA. 38+561.561 N.B.)

- (A) AGGREGATE SHOULDER, TYPE B
- (B) LIME MODIFIED SOIL, 305 mm
- (C) P.C.C. SHOULDERS, 305 mm
- (D) HOT MIX ASPHALT OVERLAY, 108 mm & VARIES
- (E) HOT MIX ASPHALT SHOULDERS
- (F) P.C.C. PAVEMENT, 254 mm
- (G) SUB-BASE GRANULAR MATERIAL, 153 mm
- (H) SUB-SURFACE DRAINAGE SYSTEM
- (I) P.C.C. PAVEMENT, 305 mm
- (J) P.C.C. SHOULDER, 273 mm
- (K) P.C.C. PAVEMENT, 273 mm
- (L) STABILIZED SUB-BASE, 102 mm
- (M) P.C.C. APPROACH SLAB, 305 mm
- (N) DOUBLE FACED CONCRETE BARRIER
- (O) POROUS GRANULAR EMBANKMENT, SUBGRADE 300 mm

EXISTING TYPICAL SECTIONS
 FAI 55 (I-55)
 SECTION (57-4)RS-3 & I
 McCLEEN COUNTY

F.A. RTE.	SECTION	COUNTY	TOTAL SHEETS	SHEET NO.
55	•	McCLENNAN	87	15
STA.		TO STA.		
FED. ROAD DIST. NO.	ILLINOIS	FED. AID PROJECT		
• (57-4)RS-3 & I				

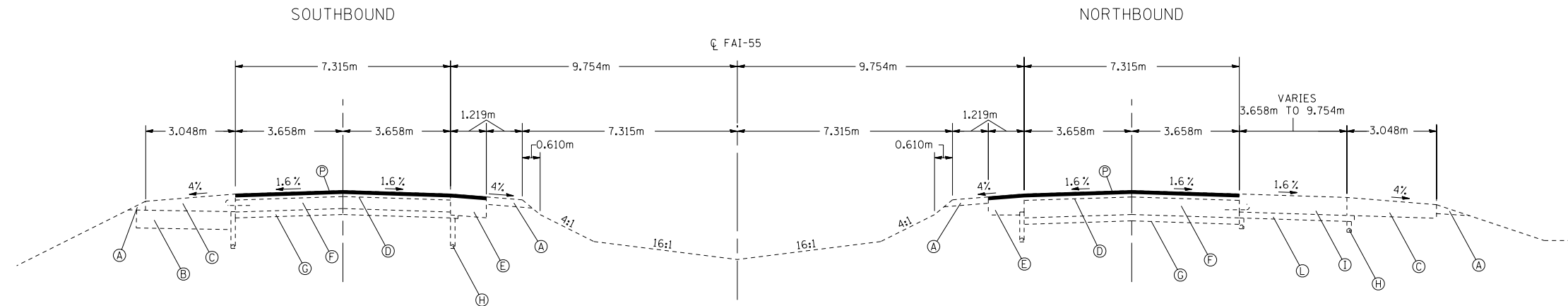

TYPICAL SECTION
STA. 36+500 TO STA. 36+630.189 N.B. & S.B.

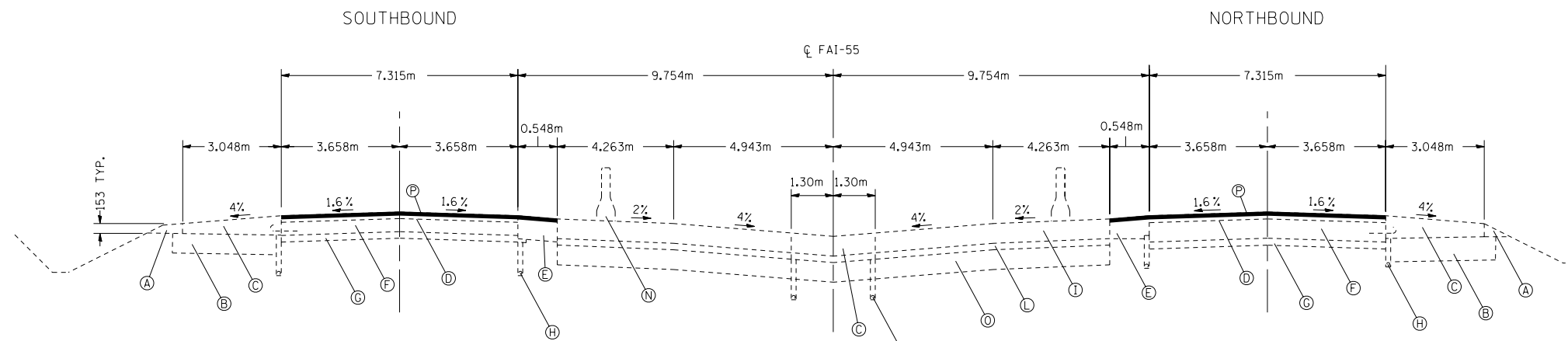

TYPICAL SECTION
STA. 36+305 TO STA. 36+500 N.B. & S.B.

Ⓟ HOT MIX ASPHALT SURFACE REMOVAL 35 mm AND
POLYMERIZED HOT MIX ASPHALT SURFACE
COURSE, MIX E, NI05 38 mm

- ⓐ EXISTING AGGREGATE SHOULDER, TYPE B
- ⓑ EXISTING LIME MODIFIED SOIL, 305 mm
- ⓒ EXISTING P.C.C. SHOULDERS, 305 mm
- ⓓ EXISTING HOT MIX ASPHALT OVERLAY, 108 mm & VARIES
- ⓔ EXISTING HOT MIX ASPHALT SHOULDERS
- ⓕ EXISTING P.C.C. PAVEMENT, 254 mm
- ⓖ EXISTING SUB GRANULAR MATERIAL, 153 mm
- ⓗ EXISTING SUB-SURFACE DRAINAGE SYSTEM
- ⓘ EXISTING P.C.C. PAVEMENT, 305 mm
- ⓙ EXISTING P.C.C. SHOULDER, 273 mm
- ⓚ EXISTING P.C.C. PAVEMENT, 273 mm
- ⓛ EXISTING STABILIZED SUB-BASE, 102 mm
- ⓜ EXISTING P.C.C. APPROACH SLAB, 305 mm
- ⓝ EXISTING DOUBLE FACED CONCRETE BARRIER
- ⓞ EXISTING POROUS GRANULAR EMBANKMENT, SUBGRADE 300 mm

PROPOSED TYPICAL SECTIONS
FAI 55 (I-55)
SECTION (57-4)RS-3 & I
McCLENNAN COUNTY

F.A. RTE.	SECTION	COUNTY	TOTAL SHEETS	SHEET NO.
55	•	McCLEAN	87	16
STA.		TO STA.		
FED. ROAD DIST. NO.		ILLINOIS FED. AID PROJECT		
• (57-4)RS-3 & I				

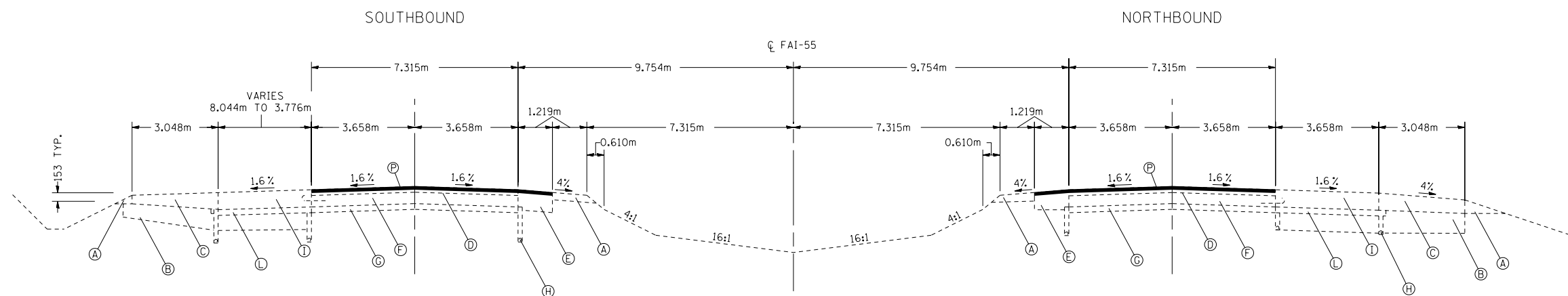

TYPICAL SECTION
 STA. 36+803.794 TO STA. 37+084.421 N.B.
 STA. 36+803.794 TO STA. 37+017.154 S.B.

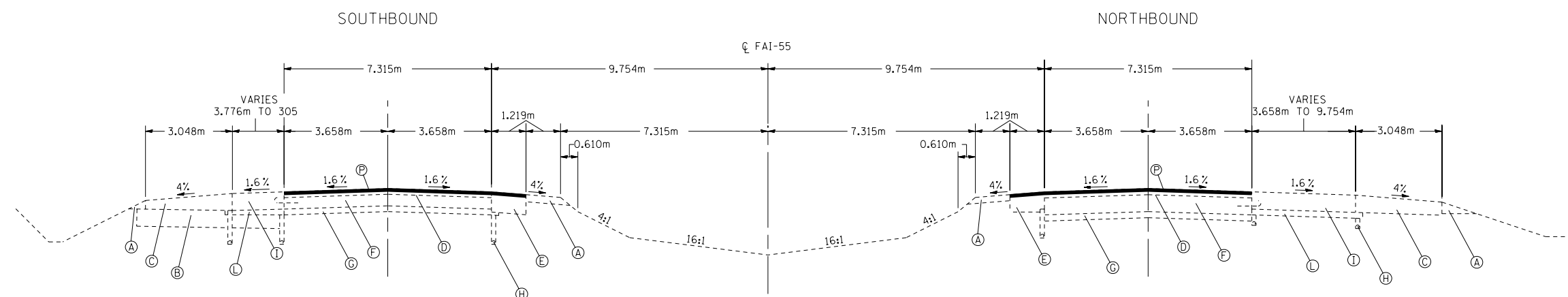

TYPICAL SECTION
 STA. 36+630.189 TO STA. 36+803.794 N.B. & S.B.

- (A) EXISTING AGGREGATE SHOULDER, TYPE B
- (B) EXISTING LIME MODIFIED SOIL, 305 mm
- (C) EXISTING P.C.C. SHOULDERS, 305 mm
- (D) EXISTING HOT MIX ASPHALT OVERLAY, 108 mm & VARIES
- (E) EXISTING HOT MIX ASPHALT SHOULDERS
- (F) EXISTING P.C.C. PAVEMENT, 254 mm
- (G) EXISTING SUB GRANULAR MATERIAL, 153 mm
- (H) EXISTING SUB-SURFACE DRAINAGE SYSTEM
- (I) EXISTING P.C.C. PAVEMENT, 305 mm
- (J) EXISTING P.C.C. SHOULDER, 273 mm
- (K) EXISTING P.C.C. PAVEMENT, 273 mm
- (L) EXISTING STABILIZED SUB-BASE, 102 mm
- (M) EXISTING P.C.C. APPROACH SLAB, 305 mm
- (N) EXISTING DOUBLE FACED CONCRETE BARRIER
- (O) EXISTING POROUS GRANULAR EMBANKMENT, SUBGRADE 300 mm

(P) HOT MIX ASPHALT SURFACE REMOVAL 35 mm AND
 POLYMERIZED HOT MIX ASPHALT SURFACE
 COURSE, MIX E, N105 38 mm

PROPOSED TYPICAL SECTIONS
 FAI 55 (I-55)
 SECTION (57-4)RS-3 & I
 McCLEAN COUNTY

F.A. RTE.	SECTION	COUNTY	TOTAL SHEETS	SHEET NO.
55	•	McCLEAN	87	17
STA.		TO STA.		
FED. ROAD DIST. NO.		ILLINOIS FED. AID PROJECT		
• (57-4)RS-3 & I				

•• VARIES 3.048m TO 1.829m
STA. 37+407.430 TO STA. 37+370.823

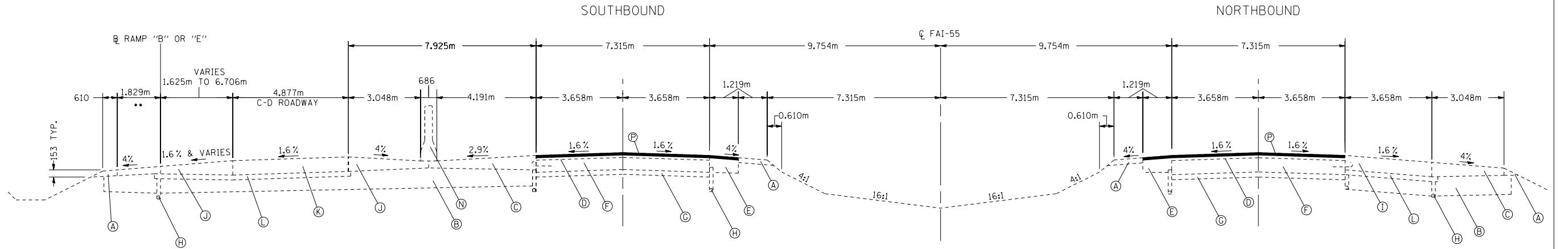

TYPICAL SECTION
STA. 37+231.545 TO STA. 37+412.956 N.B.
STA. 37+255.030 TO STA. 37+410.902 S.B.

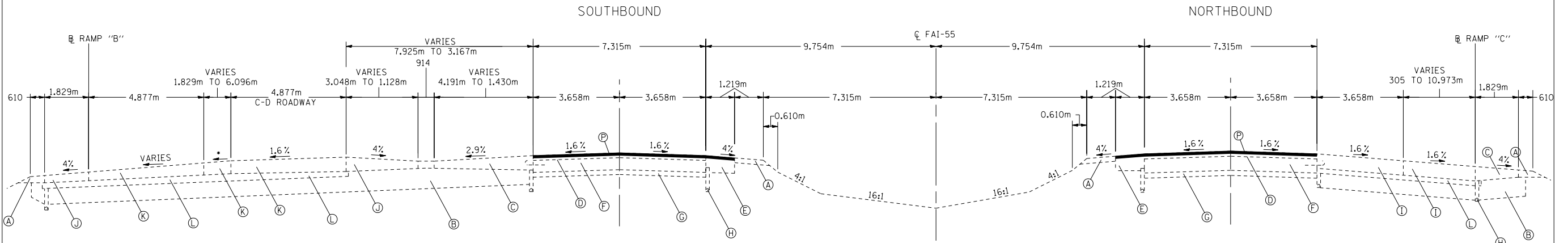

TYPICAL SECTION
STA. 37+084.421 TO STA. 37+231.545 N.B.
STA. 37+017.154 TO STA. 37+255.030 S.B.

- (A) EXISTING AGGREGATE SHOULDER, TYPE B
- (B) EXISTING LIME MODIFIED SOIL, 305 mm
- (C) EXISTING P.C.C. SHOULDERS, 305 mm
- (D) EXISTING HOT MIX ASPHALT OVERLAY, 108 mm & VARIES
- (E) EXISTING HOT MIX ASPHALT SHOULDERS
- (F) EXISTING P.C.C. PAVEMENT, 254 mm
- (G) EXISTING SUB GRANULAR MATERIAL, 153 mm
- (H) EXISTING SUB-SURFACE DRAINAGE SYSTEM
- (I) EXISTING P.C.C. PAVEMENT, 305 mm
- (J) EXISTING P.C.C. SHOULDER, 273 mm
- (K) EXISTING P.C.C. PAVEMENT, 273 mm
- (L) EXISTING STABILIZED SUB-BASE, 102 mm
- (M) EXISTING P.C.C. APPROACH SLAB, 305 mm
- (N) EXISTING DOUBLE FACED CONCRETE BARRIER
- (O) EXISTING POROUS GRANULAR EMBANKMENT, SUBGRADE 300 mm

(P) HOT MIX ASPHALT SURFACE REMOVAL 35 mm AND
POLYMERIZED HOT MIX ASPHALT SURFACE
COURSE, MIX E, N105 38 mm

PROPOSED TYPICAL SECTIONS
FAI 55 (I-55)
SECTION (57-4)RS-3 & I
McCLEAN COUNTY

F.A. RTE.	SECTION	COUNTY	TOTAL SHEETS	SHEET NO.
55	*	McCLEAN	87	18
STA.		TO STA.		
FED. ROAD DIST. NO.		ILLINOIS FED. AID PROJECT		
• (57-4)RS-3 & I				

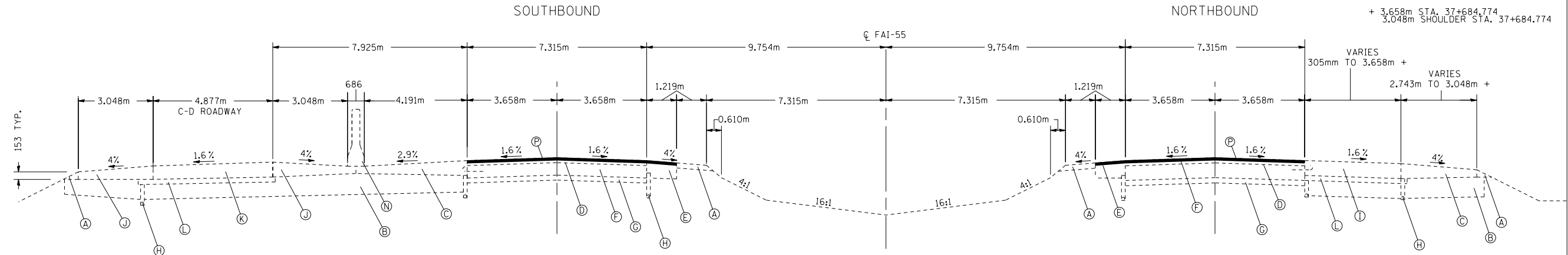

TYPICAL SECTION
 STA. 37+643.215 TO STA. 37+852.415 N.B.
 STA. 37+618.172 TO STA. 37+855.100 S.B.

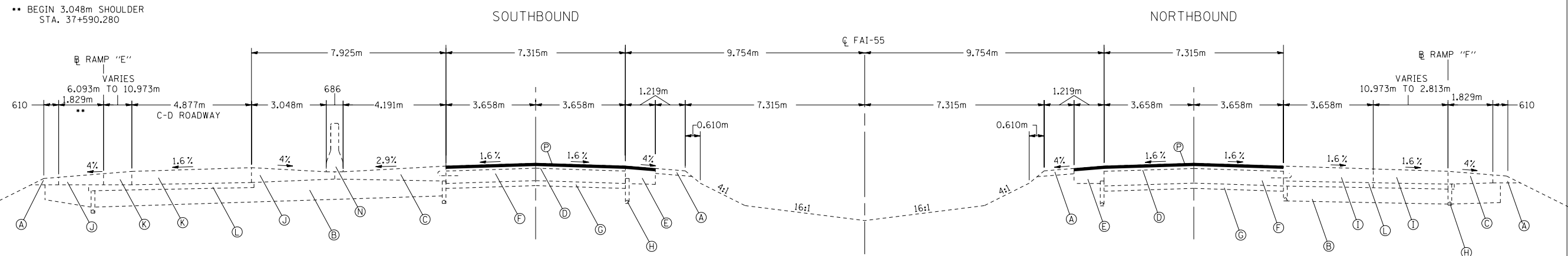

TYPICAL SECTION
 STA. 37+537.555 TO STA. 37+643.215 N.B.
 STA. 37+535.440 TO STA. 37+618.172 S.B.

- (A) EXISTING AGGREGATE SHOULDER, TYPE B
- (B) EXISTING LIME MODIFIED SOIL, 305 mm
- (C) EXISTING P.C.C. SHOULDERS, 305 mm
- (D) EXISTING HOT MIX ASPHALT OVERLAY, 108 mm & VARIES
- (E) EXISTING HOT MIX ASPHALT SHOULDERS
- (F) EXISTING P.C.C. PAVEMENT, 254 mm
- (G) EXISTING SUB GRANULAR MATERIAL, 153 mm
- (H) EXISTING SUB-SURFACE DRAINAGE SYSTEM
- (I) EXISTING P.C.C. PAVEMENT, 305 mm
- (J) EXISTING P.C.C. SHOULDER, 273 mm
- (K) EXISTING P.C.C. PAVEMENT, 273 mm
- (L) EXISTING STABILIZED SUB-BASE, 102 mm
- (M) EXISTING P.C.C. APPROACH SLAB, 305 mm
- (N) EXISTING DOUBLE FACED CONCRETE BARRIER
- (O) EXISTING POROUS GRANULAR EMBANKMENT, SUBGRADE 300 mm

(P) HOT MIX ASPHALT SURFACE REMOVAL 35 mm AND
 POLYMERIZED HOT MIX ASPHALT SURFACE
 COURSE, MIX E, N105 38 mm

PROPOSED TYPICAL SECTIONS
 FAI 55 (I-55)
 SECTION (57-4)RS-3 & I
 McCLEAN COUNTY

F.A. RTE.	SECTION	COUNTY	TOTAL SHEETS	SHEET NO.
55	•	McCLEAN	87	19
STA.		TO STA.		
FED. ROAD DIST. NO.		ILLINOIS FED. AID PROJECT		
• (57-4)RS-3 & I				

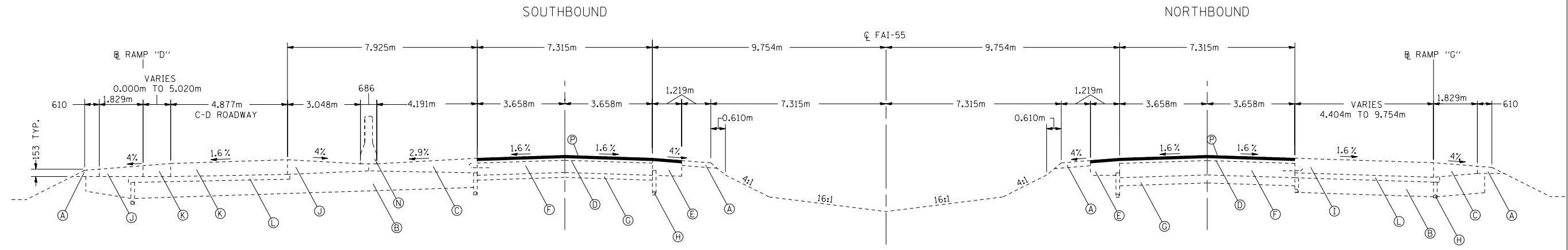

TYPICAL SECTION
STA. 37+966.007 TO 38+116.652 N.B. & S.B.

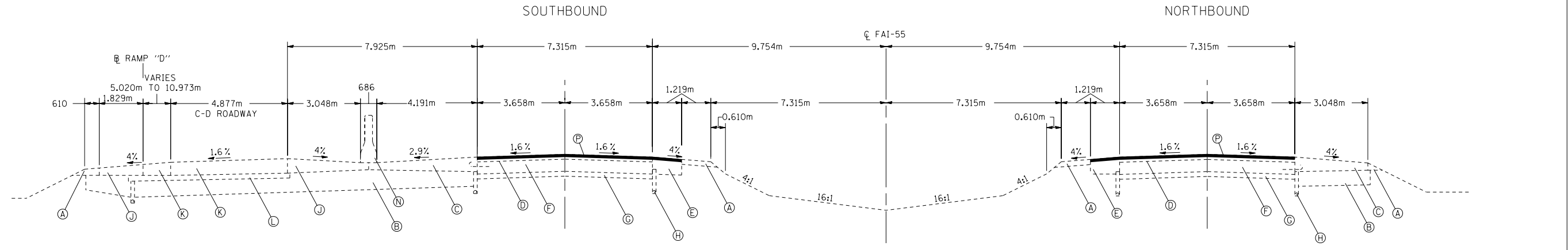

TYPICAL SECTION
STA. 37+852.415 TO STA. 37+966.007 N.B.
STA. 37+855.100 TO STA. 37+966.007 S.B.

- (A) EXISTING AGGREGATE SHOULDER, TYPE B
- (B) EXISTING LIME MODIFIED SOIL, 305 mm
- (C) EXISTING P.C.C. SHOULDERS, 305 mm
- (D) EXISTING HOT MIX ASPHALT OVERLAY, 108 mm & VARIES
- (E) EXISTING HOT MIX ASPHALT SHOULDERS
- (F) EXISTING P.C.C. PAVEMENT, 254 mm
- (G) EXISTING SUB GRANULAR MATERIAL, 153 mm
- (H) EXISTING SUB-SURFACE DRAINAGE SYSTEM
- (I) EXISTING P.C.C. PAVEMENT, 305 mm
- (J) EXISTING P.C.C. SHOULDER, 273 mm
- (K) EXISTING P.C.C. PAVEMENT, 273 mm
- (L) EXISTING STABILIZED SUB-BASE, 102 mm
- (M) EXISTING P.C.C. APPROACH SLAB, 305 mm
- (N) EXISTING DOUBLE FACED CONCRETE BARRIER
- (O) EXISTING POROUS GRANULAR EMBANKMENT, SUBGRADE 300 mm

(P) HOT MIX ASPHALT SURFACE REMOVAL 35 mm AND
POLYMERIZED HOT MIX ASPHALT SURFACE
COURSE, MIX E, N105 38 mm

PROPOSED TYPICAL SECTIONS
FAI 55 (I-55)
SECTION (57-4)RS-3 & I
McCLEAN COUNTY

F.A. RTE.	SECTION	COUNTY	TOTAL SHEETS	SHEET NO.
55	•	McCLEEN	87	20
STA.		TO STA.		
FED. ROAD DIST. NO.		ILLINOIS FED. AID PROJECT		
• (57-4)RS-3 & I				

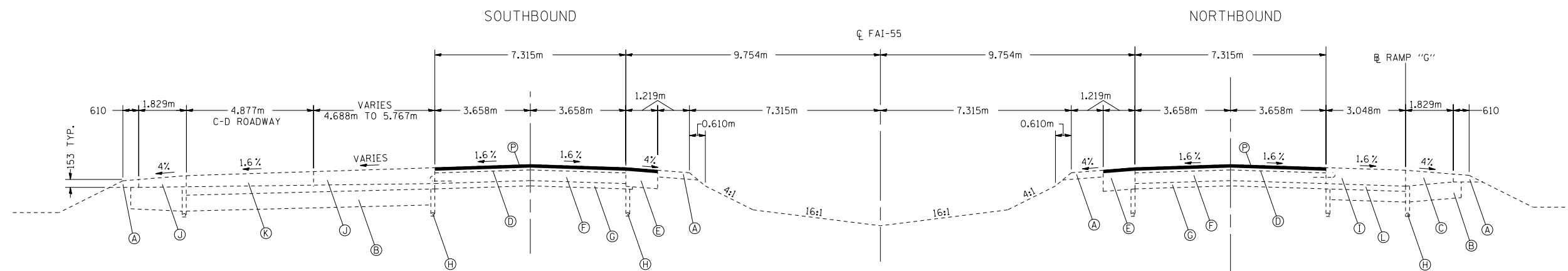

TYPICAL SECTION

STA. 38+177.850 TO STA. 38+210.808 N.B.

STA. 38+177.850 TO STA. 38+208.330 S.B.

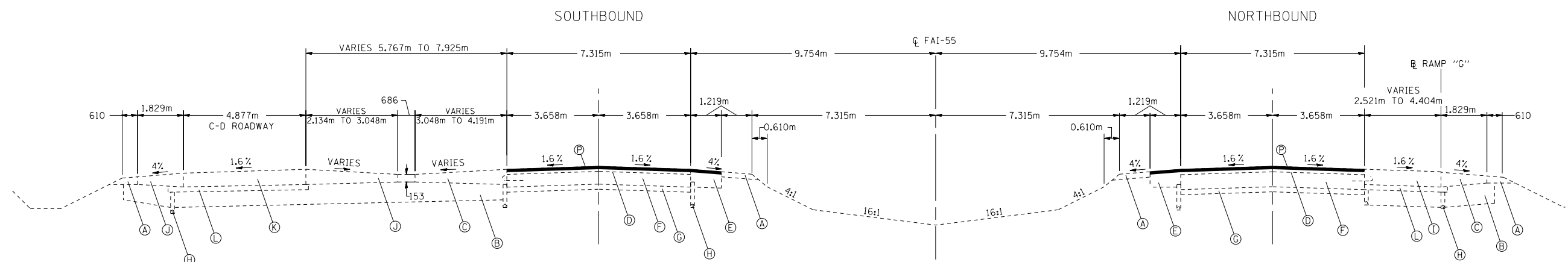

TYPICAL SECTION

STA. 38+116.652 TO STA. 38+177.850 N.B. & S.B.

- (A) EXISTING AGGREGATE SHOULDER, TYPE B
- (B) EXISTING LIME MODIFIED SOIL, 305 mm
- (C) EXISTING P.C.C. SHOULDERS, 305 mm
- (D) EXISTING HOT MIX ASPHALT OVERLAY, 108 mm & VARIES
- (E) EXISTING HOT MIX ASPHALT SHOULDERS
- (F) EXISTING P.C.C. PAVEMENT, 254 mm
- (G) EXISTING SUB GRANULAR MATERIAL, 153 mm
- (H) EXISTING SUB-SURFACE DRAINAGE SYSTEM
- (I) EXISTING P.C.C. PAVEMENT, 305 mm
- (J) EXISTING P.C.C. SHOULDER, 273 mm
- (K) EXISTING P.C.C. PAVEMENT, 273 mm
- (L) EXISTING STABILIZED SUB-BASE, 102 mm
- (M) EXISTING P.C.C. APPROACH SLAB, 305 mm
- (N) EXISTING DOUBLE FACED CONCRETE BARRIER
- (O) EXISTING POROUS GRANULAR EMBANKMENT, SUBGRADE 300 mm

(P) HOT MIX ASPHALT SURFACE REMOVAL 35 mm AND
POLYMERIZED HOT MIX ASPHALT SURFACE
COURSE, MIX E, N105 38 mm

PROPOSED TYPICAL SECTIONS
FAI 55 (I-55)
SECTION (57-4)RS-3 & I
McCLEEN COUNTY

F.A. RTE.	SECTION	COUNTY	TOTAL SHEETS	SHEET NO.
55	•	McCLEAN	87	21
STA.		TO STA.		
FED. ROAD DIST. NO.		ILLINOIS FED. AID PROJECT		
• (57-4)RS-3 & I				

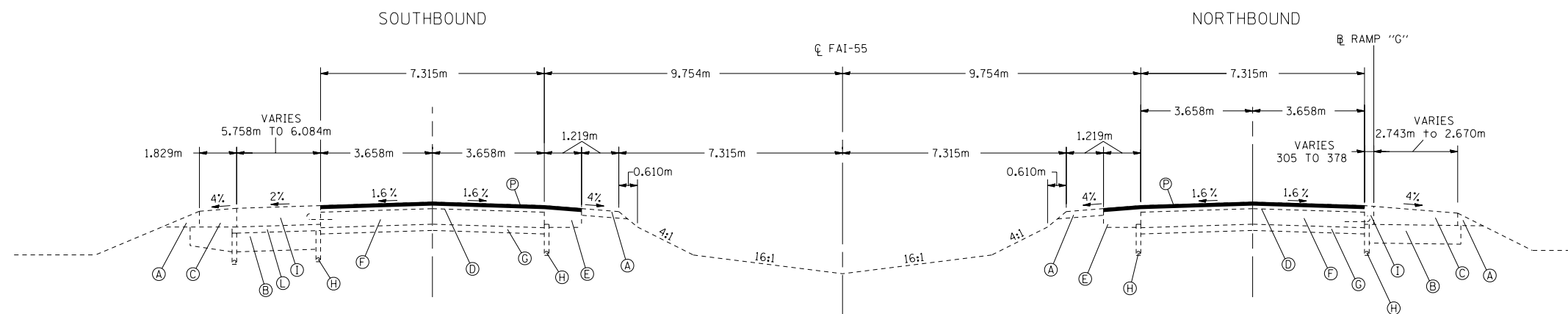

TYPICAL SECTION

STA. 38+317.995 TO STA. 38+321.655 N.B.
 STA. 38+315.520 TO STA. 38+321.655 S.B.

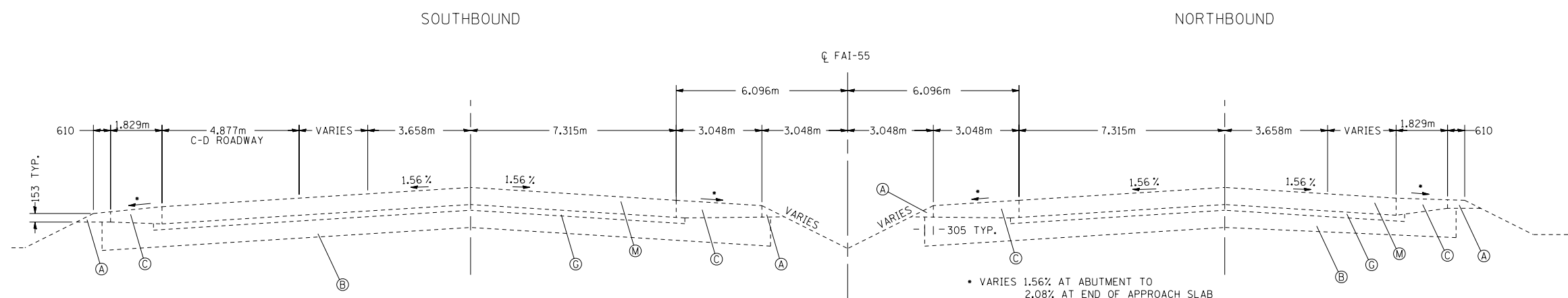

TYPICAL SECTION

STA. 38+210.808 TO STA. 38+241.288 AND STA. 38+287.515 TO STA. 38+317.995 N.B.
 STA. 38+208.333 TO STA. 38+238.813 AND STA. 38+285.040 TO STA. 38+315.520 S.B.

- (A) EXISTING AGGREGATE SHOULDER, TYPE B
- (B) EXISTING LIME MODIFIED SOIL, 305 mm
- (C) EXISTING P.C.C. SHOULDERS, 305 mm
- (D) EXISTING HOT MIX ASPHALT OVERLAY, 108 mm & VARIES
- (E) EXISTING HOT MIX ASPHALT SHOULDERS
- (F) EXISTING P.C.C. PAVEMENT, 254 mm
- (G) EXISTING SUB GRANULAR MATERIAL, 153 mm
- (H) EXISTING SUB-SURFACE DRAINAGE SYSTEM
- (I) EXISTING P.C.C. PAVEMENT, 305 mm
- (J) EXISTING P.C.C. SHOULDER, 273 mm
- (K) EXISTING P.C.C. PAVEMENT, 273 mm
- (L) EXISTING STABILIZED SUB-BASE, 102 mm
- (M) EXISTING P.C.C. APPROACH SLAB, 305 mm
- (N) EXISTING DOUBLE FACED CONCRETE BARRIER
- (O) EXISTING POROUS GRANULAR EMBANKMENT, SUBGRADE 300 mm

(P) HOT MIX ASPHALT SURFACE REMOVAL 35 mm AND
 POLYMERIZED HOT MIX ASPHALT SURFACE
 COURSE, MIX E, N105 38 mm

PROPOSED TYPICAL SECTIONS
 FAI 55 (I-55)
 SECTION (57-4)RS-3 & I
 McCLEAN COUNTY

F.A. RTE.	SECTION	COUNTY	TOTAL SHEETS	SHEET NO.
55	•	McCLEAN	87	22
STA.		TO STA.		
FED. ROAD DIST. NO.	ILLINOIS	FED. AID PROJECT		
• (57-4)RS-3 & I				

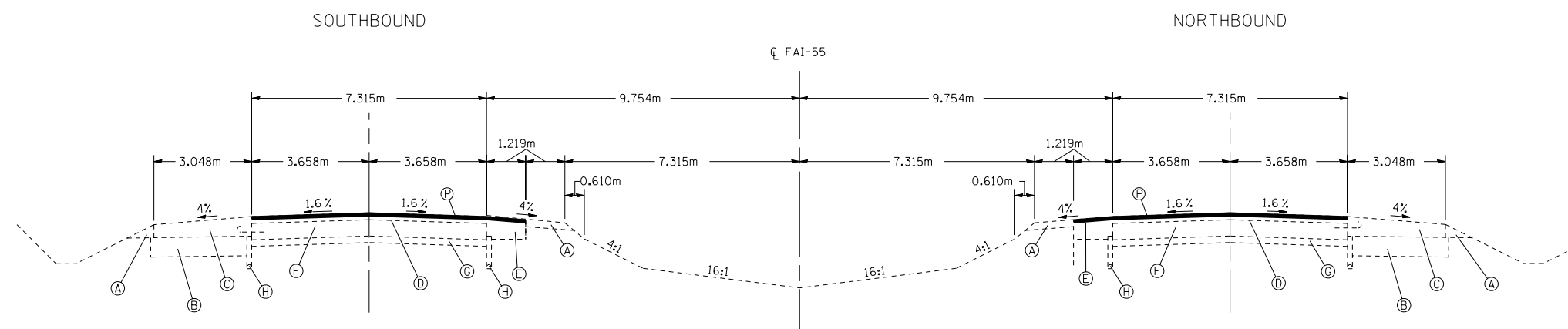

TYPICAL SECTION
STA. 38+424.504 TO STA. 38+480.197 N.B. & S.B.

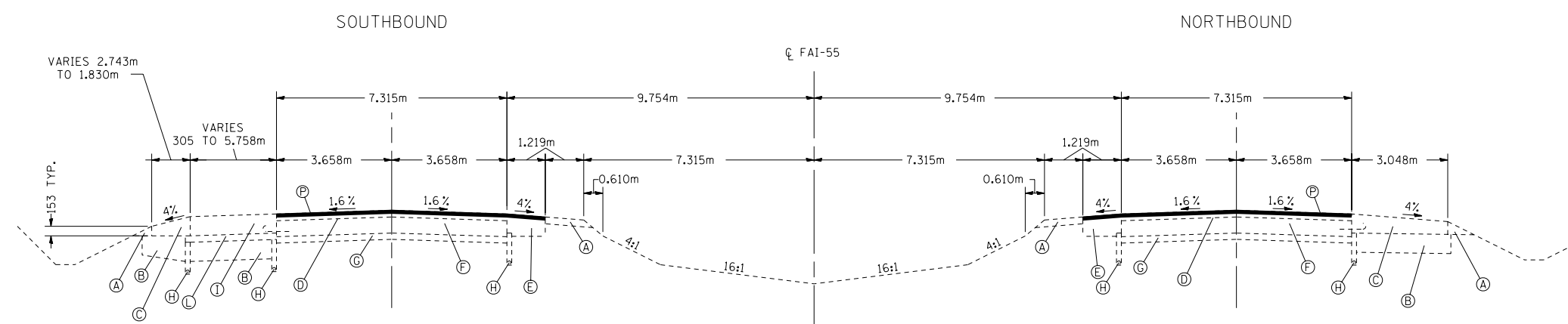

TYPICAL SECTION
STA. 38+321.655 TO STA. 38+424.504 N.B. & S.B.

- (A) EXISTING AGGREGATE SHOULDER, TYPE B
- (B) EXISTING LIME MODIFIED SOIL, 305 mm
- (C) EXISTING P.C.C. SHOULDERS, 305 mm
- (D) EXISTING HOT MIX ASPHALT OVERLAY, 108 mm & VARIES
- (E) EXISTING HOT MIX ASPHALT SHOULDERS
- (F) EXISTING P.C.C. PAVEMENT, 254 mm
- (G) EXISTING SUB GRANULAR MATERIAL, 153 mm
- (H) EXISTING SUB-SURFACE DRAINAGE SYSTEM
- (I) EXISTING P.C.C. PAVEMENT, 305 mm
- (J) EXISTING P.C.C. SHOULDER, 273 mm
- (K) EXISTING P.C.C. PAVEMENT, 273 mm
- (L) EXISTING STABILIZED SUB-BASE, 102 mm
- (M) EXISTING P.C.C. APPROACH SLAB, 305 mm
- (N) EXISTING DOUBLE FACED CONCRETE BARRIER
- (O) EXISTING POROUS GRANULAR EMBANKMENT, SUBGRADE 300 mm

(P) HOT MIX ASPHALT SURFACE REMOVAL 35 mm AND
POLYMERIZED HOT MIX ASPHALT SURFACE
COURSE, MIX E, N105 38 mm

PROPOSED TYPICAL SECTIONS
FAI 55 (I-55)
SECTION (57-4)RS-3 & I
McCLEAN COUNTY

F.A. RTE.	SECTION	COUNTY	TOTAL SHEETS	SHEET NO.
55	•	MCCLEAN	87	23
STA.		TO STA.		
FED. ROAD DIST. NO.		ILLINOIS FED. AID PROJECT		
• (57-4)RS-3 & I				

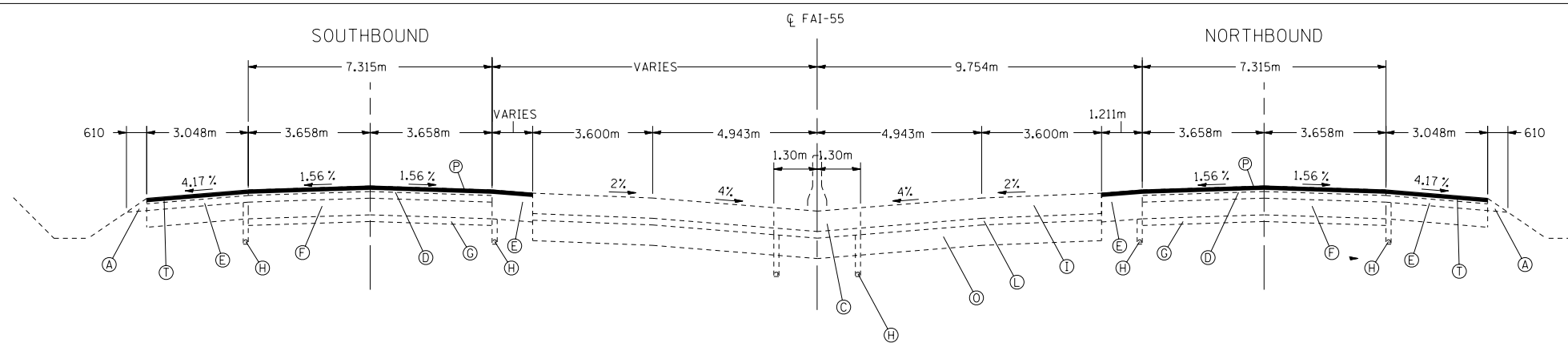

TYPICAL SECTION
STA. 40+270.000 TO STA. 40+486.00 N.B. & S.B.

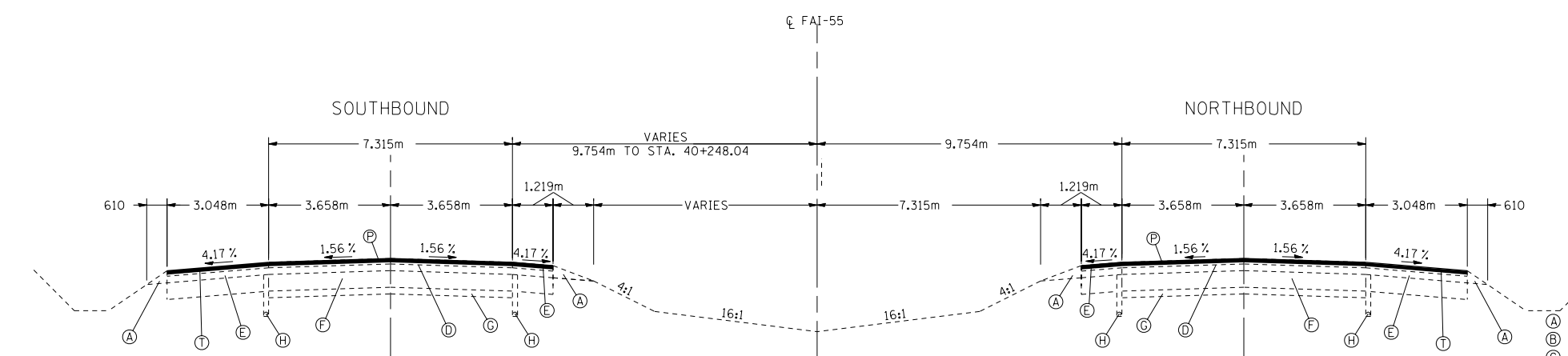

TYPICAL SECTION
STA. 38+480.197 TO STA. 38+525.439 S.B.
STA. 38+480.197 TO STA. 38+526.652 N.B.
STA. 40+216.300 TO STA. 40+270.000 N.B. & S.B.
(BRIDGE OMISSION STA. 38+525.439 TO STA. 38+560.482 S.B.)
STA. 38+526.652 TO STA. 38+561.561 N.B.)

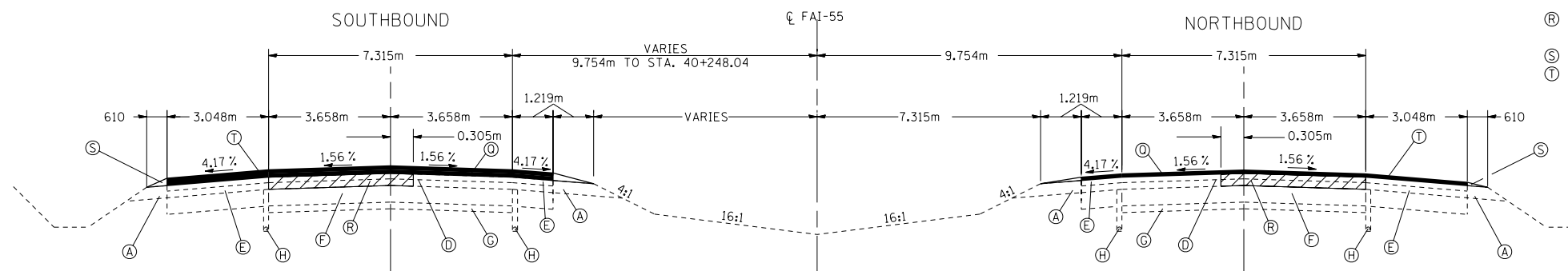

TYPICAL SECTION
STA. 38+560.482 TO STA. 40+216.300 S.B.
STA. 38+561.561 TO STA. 40+216.300 N.B.

- (A) EXISTING AGGREGATE SHOULDER, TYPE B
- (B) EXISTING LIME MODIFIED SOIL, 305 mm
- (C) EXISTING P.C.C. SHOULDERS, 305 mm
- (D) EXISTING HOT MIX ASPHALT OVERLAY, 108 mm & VARIES
- (E) EXISTING HOT MIX ASPHALT SHOULDERS
- (F) EXISTING P.C.C. PAVEMENT, 254 mm
- (G) EXISTING SUB GRANULAR MATERIAL, 153 mm
- (H) EXISTING SUB-SURFACE DRAINAGE SYSTEM
- (I) EXISTING P.C.C. PAVEMENT, 305 mm
- (J) EXISTING P.C.C. SHOULDER, 273 mm
- (K) EXISTING P.C.C. PAVEMENT, 273 mm
- (L) EXISTING STABILIZED SUB-BASE, 102 mm
- (M) EXISTING P.C.C. APPROACH SLAB, 305 mm
- (N) EXISTING DOUBLE FACED CONCRETE BARRIER
- (O) EXISTING POROUS GRANULAR EMBANKMENT, SUBGRADE 300 mm
- (P) HOT MIX ASPHALT SURFACE REMOVAL 35 mm AND POLYMERIZED HOT MIX ASPHALT SURFACE COURSE, MIX E, N105, 38mm
- (Q) POLYMERIZED HOT MIX ASPHALT SURFACE COURSE, MIX E, N105, 38mm
- (R) HOT MIX ASPHALT SURFACE REMOVAL, 110 mm AND POLYMERIZED HOT-MIX ASPHALT BINDER COURSE, IL-19.0, N105
- (S) AGGREGATE SHOULDERS TYPE B
- (T) HOT MIX ASPHALT SHOULDERS, 38 mm (OUTSIDE SHOULDERS ONLY)

F.A.I. RTE.	SECTION	COUNTY	TOTAL SHEETS	SHEET NO.
55		McLEAN	87	24

STA.		TO STA.	
FED. ROAD DIST. NO.	ILLINOIS	FED. AID PROJECT	
(57-4)RS-3 & I			

PAVEMENT PATCHING SCHEDULE							
STATION	DIRECTION	LANE	LENGTH (m)	WIDTH (m)	DEPTH (mm)	M4422350	M4424350
						PAVEMENT PATCHING TYPE II, 350mm (sq. m)	PAVEMENT PATCHING TYPE IV, 350mm (sq. m)
PATCHING PRIOR TO HMA SURFACE REMOVAL 35 mm							
37+317	SOUTHBOUND	PASSING	6.1	3.6	362		22.0
37+334	SOUTHBOUND	PASSING	6.1	3.6	362		22.0
37+591	SOUTHBOUND	PASSING	9.1	3.6	362		32.8
37+605	SOUTHBOUND	PASSING	2.4	3.6	362	8.6	
37+619	SOUTHBOUND	PASSING	2.4	3.6	362	8.6	
37+710	SOUTHBOUND	PASSING	3.0	3.6	362	10.8	
37+718	SOUTHBOUND	PASSING	7.6	3.6	362		27.4
37+800	SOUTHBOUND	PASSING	2.5	3.6	362	9.0	
37+902	SOUTHBOUND	PASSING	2.4	3.6	362	8.6	
37+930	SOUTHBOUND	PASSING	3.0	3.6	362	10.8	
38+043	SOUTHBOUND	PASSING	3.0	3.6	362	10.8	
38+072	SOUTHBOUND	PASSING	3.7	3.6	362	13.3	
38+269	SOUTHBOUND	PASSING	3.7	3.6	362	13.3	
38+284	SOUTHBOUND	PASSING	7.6	3.6	362		27.4
38+385	SOUTHBOUND	PASSING	3.0	3.6	362	10.8	
38+506	SOUTHBOUND	PASSING	9.1	3.6	362		32.8
38+533	SOUTHBOUND	PASSING	9.1	3.6	362		32.8
PATCHING PRIOR TO HMA SURFACE COURSE 38 mm							
38+567	SOUTHBOUND	PASSING	9.1	3.6	362		32.8
38+765	SOUTHBOUND	PASSING	10.0	3.6	362		36.0
40+013	SOUTHBOUND	PASSING	1.8	3.6	362	6.5	
SOUTHBOUND PASSING LANE TOTALS						111.2	265.7
PATCHING PRIOR TO HMA SURFACE REMOVAL 35 mm							
36+816	NORTHBOUND	PASSING	3.0	3.6	362	10.8	
37+394	NORTHBOUND	PASSING	3.0	3.6	362	10.8	
38+351	NORTHBOUND	PASSING	2.0	3.6	362	7.2	
38+509	NORTHBOUND	PASSING	12.0	3.6	362		43.2
PATCHING PRIOR TO HMA SURFACE COURSE 38 mm							
38+560	NORTHBOUND	PASSING	12.0	3.6	362		43.2
38+635	NORTHBOUND	PASSING	3.0	3.6	362	10.8	
NORTHBOUND PASSING LANE TOTALS						39.6	86.4
PASSING LANE TOTALS						150.8	352.1

28000500 - INLET AND PIPE PROTECTION	
LOCATION	EACH
STA. 36+941, LT.	1
MEDIAN STA. 37+050	1
MEDIAN STA. 37+195	1
TOTAL	3

LOCATION	TRAFFIC BARRIER TERMINALS					
	TRAFFIC BARRIER TERMINAL TY. 6	TRAFFIC BARRIER TERMINAL TY. 6A	TRAFFIC BARRIER TY. 1 (TANGENT)	TRAFFIC BARRIER TERMINAL REMOVAL TY. 1	TRAFFIC BARRIER TERMINAL TY. 5A	TRAFFIC BARRIER TERMINAL REMOVAL TY. 6
	63100085	63100087	63100167	63304385	63304705	63304805
STA. 37+049.591, RT. - STA. 37+064.768, RT.	---	---	1	---	---	---
STA. 37+319.668, RT. - STA. 37+334.868, RT.	---	---	1	---	---	---
STA. 37+349.727, RT. - STA. 37+364.904, RT.	---	---	1	1	---	---
STA. 37+399.634, RT. - STA. 37+413.550, RT.	1	---	---	---	---	---
STA. 37+430.502, RT. - STA. 37+444.418, RT.	1	---	---	---	---	1
STA. 37+502.545, LT. - STA. 37+516.461, LT.	1	---	---	---	---	1
STA. 37+534.386, LT. - STA. 37+548.302, LT.	1	---	---	---	---	---
STA. 37+581.934, LT. - STA. 37+597.111, LT.	---	---	1	1	---	---
STA. 37+613.069, LT. - STA. 37+628.269, LT.	---	---	1	---	---	---
STA. 38+033.271, RT. - STA. 38+048.447, RT.	---	---	1	1	---	---
STA. 38+117.680, RT. - STA. 38+132.880, RT.	---	---	1	---	---	---
STA. 38+197.647, RT. - STA. 38+211.563, RT.	1	---	---	---	---	---
STA. 38+227.915, RT. - STA. 38+241.831, RT.	1	---	---	---	---	1
STA. 38+285.837, LT. - STA. 38+299.753, LT.	1	---	---	---	---	1
STA. 38+314.382, LT. - STA. 38+328.298, LT.	1	---	---	---	---	---
STA. 38+393.065, LT. - STA. 38+408.265, LT.	---	---	1	---	---	---
STA. 38+400.879, RT. - STA. 38+416.079, RT.	---	---	1	---	---	---
STA. 38+511.326, RT. - STA. 38+525.242, RT.	1	---	---	---	---	---
STA. 38+513.505, RT. - STA. 38+527.421, RT.	---	1	---	---	1	---
STA. 38+559.241, LT. - STA. 38+573.157, LT.	---	1	---	---	1	---
STA. 38+562.089, LT. - STA. 38+576.005, LT.	1	---	---	---	---	---
STA. 38+633.431, LT. - STA. 38+648.631, LT.	---	---	1	1	---	---
STA. 38+671.252, LT. - STA. 38+686.452, LT.	---	---	1	---	---	---
STA. 40+155.956, RT. - STA. 40+171.156, RT.	---	---	1	1	---	---
STA. 40+330.874, LT. - STA. 40+346.074, LT.	---	---	1	1	---	---
TOTAL	10	2	13	7	2	4

78100100 - RAISED REFLECTIVE PAVEMENT MARKER	
LOCATION	EACH
STA. 36+305.00, LT. - STA. 40+486.00, LT.	335
STA. 36+305.00, RT. - STA. 40+486.00, RT.	336
STA. 38+112.99, LT. - STA. 38+421.73, LT.	22
STA. 36+650.95, RT. - STA. 37+650.82, RT.	75
TOTAL	768

PAVEMENT PATCHING SCHEDULE (CONT.)							
STATION	DIRECTION	LANE	LENGTH (m)	WIDTH (m)	DEPTH (mm)	M4422350	M4424350
						PAVEMENT PATCHING TYPE II, 350mm (sq. m)	PAVEMENT PATCHING TYPE IV, 350mm (sq. m)
PATCHING PRIOR TO HMA SURFACE REMOVAL 35 mm							
36+339	SOUTHBOUND	DRIVING	1.8	3.6	362	6.5	
36+400	SOUTHBOUND	DRIVING	3.0	3.6	362	10.8	
36+800	SOUTHBOUND	DRIVING	2.0	3.6	362	7.2	
36+860	SOUTHBOUND	DRIVING	10.0	3.6	362		36.0
36+880	SOUTHBOUND	DRIVING	10.0	3.6	362		36.0
36+940	SOUTHBOUND	DRIVING	3.0	3.6	362	10.8	
36+991	SOUTHBOUND	DRIVING	7.6	3.6	362		27.4
37+403	SOUTHBOUND	DRIVING	1.8	3.6	362	6.5	
37+420	SOUTHBOUND	DRIVING	1.8	3.6	362	6.5	
37+472	SOUTHBOUND	DRIVING	3.0	3.6	362	10.8	
37+489	SOUTHBOUND	DRIVING	7.6	3.6	362		27.4
37+591	SOUTHBOUND	DRIVING	9.1	3.6	362		32.8
37+605	SOUTHBOUND	DRIVING	2.4	3.6	362	8.6	
37+619	SOUTHBOUND	DRIVING	15.2	3.6	362		54.7
37+633	SOUTHBOUND	DRIVING	1.8	3.6	362	6.5	
37+647	SOUTHBOUND	DRIVING	3.0	3.6	362	10.8	
37+662	SOUTHBOUND	DRIVING	1.8	3.6	362	6.5	
37+676	SOUTHBOUND	DRIVING	1.8	3.6	362	6.5	
37+718	SOUTHBOUND	DRIVING	3.0	3.6	362	10.8	
38+000	SOUTHBOUND	DRIVING	2.0	3.6	362	7.2	
38+043	SOUTHBOUND	DRIVING	3.0	3.6	362	10.8	
38+156	SOUTHBOUND	DRIVING	2.4	3.6	362	8.6	
38+185	SOUTHBOUND	DRIVING	2.4	3.6	362	8.6	
38+199	SOUTHBOUND	DRIVING	3.0	3.6	362	10.8	
38+213	SOUTHBOUND	DRIVING	9.1	3.6	362		32.8
38+269	SOUTHBOUND	DRIVING	3.7	3.6	362	13.3	
38+284	SOUTHBOUND	DRIVING	7.6	3.6	362		27.4
38+479	SOUTHBOUND	DRIVING	3.0	3.6	362	10.8	
38+506	SOUTHBOUND	DRIVING	9.1	3.6	362		32.8
38+533	SOUTHBOUND	DRIVING	9.1	3.6	362		32.8
PATCHING PRIOR TO HMA SURFACE REMOVAL 110 mm							
38+567	SOUTHBOUND	DRIVING	9.1	3.6	362		32.8
39+552	SOUTHBOUND	DRIVING	3.0	3.6	362	10.8	
40+013	SOUTHBOUND	DRIVING	1.8	3.6	362	6.5	
40+044	SOUTHBOUND	DRIVING	2.0	3.6	362	7.2	
40+100	SOUTHBOUND	DRIVING	3.0	3.6	362	10.8	
SOUTHBOUND DRIVING LANE TOTALS						214.2	372.6
PATCHING PRIOR TO HMA SURFACE REMOVAL 35 mm							
36+645	NORTHBOUND	DRIVING	6.1	3.6	362		22.0
36+816	NORTHBOUND	DRIVING	3.0	3.6	362	10.8	
36+850	NORTHBOUND	DRIVING	3.0	3.6	362	10.8	
36+870	NORTHBOUND	DRIVING	6.0	3.6	362		21.6
36+952	NORTHBOUND	DRIVING	2.4	3.6	362	8.6	
36+986	NORTHBOUND	DRIVING	1.8	3.6	362	6.5	
36+995	NORTHBOUND	DRIVING	10.0	3.6	362		36.0
37+394	NORTHBOUND	DRIVING	3.0	3.6	362	10.8	
37+410	NORTHBOUND	DRIVING	1.8	3.6	362	6.5	
37+531	NORTHBOUND	DRIVING	6.1	3.6	362		22.0
37+540	NORTHBOUND	DRIVING	2.4	3.6	362	8.6	
38+098	NORTHBOUND	DRIVING	6.0	3.6	362		21.6
38+222	NORTHBOUND	DRIVING	7.7	3.6	362		27.8
38+351	NORTHBOUND	DRIVING	7.0	3.6	362		25.2
38+414	NORTHBOUND	DRIVING	1.8	3.6	362	6.5	
38+509	NORTHBOUND	DRIVING	10.0	3.6	362		36.0
PATCHING PRIOR TO HMA SURFACE REMOVAL 110 mm							
38+560	NORTHBOUND	DRIVING	12.0	3.6	362		43.2
38+730	NORTHBOUND	DRIVING	2.4	3.6	362	8.7	
PATCHING PRIOR TO HMA SURFACE REMOVAL 35 mm							
40+328	NORTHBOUND	DRIVING	3.0	3.6	362	10.8	
40+375	NORTHBOUND	DRIVING	2.4	3.6	362	8.6	
40+455	NORTHBOUND	DRIVING	2.4	3.6	362	8.6	
NORTHBOUND DRIVING LANE TOTALS						105.9	255.3
DRIVING LANE TOTALS						320.1	627.9
PAVEMENT PATCHING TOTALS						471.0	980.0

LOCATION	SEEDING					
	TOP SOIL FURNISH AND PLACE 100 MM	SEEDING CL. 2A	NITROGEN FERTILIZER NUTRIENT	PHOSPHORUS FERTILIZER NUTRIENT	POTASSIUM FERTILIZER NUTRIENT	EROSION CONTROL BLANKET
	M2113100	M2500210	M2500400	M2500500	M2500600	M2510630
STA. 37+550.0, RT.	33	0.1	10	10	10	33
TOTAL	33	0.1	10	10	10	33

78100105 - RAISED REFLECTIVE PAVEMENT MARKER (BRIDGE)	
LOCATION	EACH
BRIDGE OVER US 51	14
BRIDGE OVER CONSTITUTION TRAIL	12
TOTAL	26

78300200 - RAISED REFLECTIVE PAVEMENT MARKER REMOVAL	
LOCATION	EACH
STA. 36+305.00, LT. - STA. 37+410.915, LT.	92
STA. 36+305.00, RT. - STA. 37+412.788, RT.	157
STA. 37+535.148, LT. - STA. 38+208.251, LT.	67
STA. 37+537.248, RT. - STA. 38+210.801, RT.	66
STA. 38+315.144, LT. - STA. 40+486.000, LT.	191
STA. 38+318.062, RT. - STA. 40+486.000, RT.	180
TOTAL	753

M2140100 - GRADING AND SHAPING DITCHES	
LOCATION	METER
STA. 36+398.9, LT.	6
STA. 36+821.4, LT.	3
STA. 36+897.0, RT.	9
STA. 36+943.6, RT.	2
STA. 37+012.4, LT.	145
STA. 37+070.4, RT.	31
STA. 37+105.6, RT.	6.5
STA. 37+202.5, LT.	7.5
STA. 37+233.6, LT.	72
STA. 37+235.1, RT.	2
STA. 37+313.4, LT.	15
STA. 37+354.2, RT.	2
STA. 37+436.1, RT.	2
STA. 37+671.2, LT.	3
STA. 37+745.4, RT.	2
STA. 37+780.5, LT.	3
STA. 37+946.7, LT.	2
STA. 38+129.0, LT.	2
STA. 38+225.6, RT.	2
STA. 38+235.8, LT.	2
STA. 38+471.6, LT.	3
STA. 38+563.8, RT.	3
STA. 38+563.8, LT.	3
STA. 38+846.0, LT.	5
STA. 38+961.0, RT.	3
STA. 39+122.6, RT.	3
STA. 39+151.9, RT.	120
STA. 39+427.3, LT.	2
TOTAL	461

STONE RIP RAP		
LOCATION	STONE RIP RAP, CL. A3	STONE RIP RAP, CL. A4
	M2810105	M2810207
	SO M	M TON
STA. 36+807.5	6	
STA. 36+939.0, LT.	5	
STA. 37+051.9, RT.	12	
STA. 37+087.4, RT.	27	
STA. 37+110.0, RT.	27	
STA. 37+129.6, LT.	100	
STA. 37+197.8, LT.	12	
STA. 37+283.5, LT.	34	
STA. 37+441.2, LT.	30	
STA. 37+670.9, LT.	60	
STA. 37+700.3, RT.	60	
STA. 37+913.7, RT.	20	
STA. 37+992.0, RT.	31	
STA. 37+995.5	10	
STA. 38+478		8.1
STA. 38+494.3	30	
STA. 38+832.2</		

F.A.I. RTE.	SECTION	COUNTY	TOTAL SHEETS	SHEET NO.
55	.	McLEAN	87	25
STA.		TO STA.		
FED. ROAD DIST. NO.		ILLINOIS FED. AID PROJECT		
• (57-4)RS-3 & I				

LOCATION	PAVEMENT											
	POLYMERIZED HOT-MIX ASPHALT SURF CSE MIX E, N100	POLYMERIZED HOT-MIX ASPHALT BIND IL 19.0, N100	BITUMINOUS MATERIALS (PRIME COAT) M4060100	MIXTURE FOR CRACKS, JOINS, AND FLANGWAYS M4060400	HOT-MIX ASPHALT SHOULDERS M4820400	AGGREGATE SHOULDER, TYPE B M4812000	HOT-MIX ASPHALT SURFACE REMOVAL 35 MM M4400735	ASPHALT SURFACE REMOVAL 110 MM M4400810	HOT-MIX ASPHALT SURFACE REMOVAL (VAR. DEPTH) M4400950	INCIDENTAL HOT-MIX ASPHALT SURFACING M4080500	SHOULDER RUMBLE STRIP M6420015	MATERIAL TRANSFER DEVICE MX032584
	M TON	M TON	LITER	M TON	M TON	SO M	SO M	SO M	M TON	METER	M TON	
STA. 36+305.00 - STA. 36+500.000 LT.	139.4		537	0.5			1533.3				139.4	
STA. 36+305.00 - STA. 36+500.000 RT.	139.4		537	0.5			1533.3				139.4	
STA. 36+500.00 - STA. 37+410.908 LT.	706.6		2721	2.3			7773.6			910.9	706.6	
STA. 36+500.00 - STA. 37+412.956 RT.	708.2		2727	2.3			7791.2			912.8	708.2	
STA. 37+535.44 - STA. 38+208.330 LT.	521.9		2010	1.7			5742.4			673.2	521.9	
STA. 37+537.55 - STA. 38+210.808 RT.	522.3		2011	1.7			5745.5			673.6	522.3	
STA. 38+315.52 - STA. 38+500.000 LT.	143.1		551	0.5	5.5		1574.4			184.8	143.1	
STA. 38+317.99 - STA. 38+500.000 RT.	141.2		544	0.5	5.5		1553.2			183	141.2	
STA. 38+500.00 - STA. 38+525.439 LT.	26.9		103	0.1	7.1		295.7			25.5	26.9	
STA. 38+500.00 - STA. 38+526.652 RT.	28		108	0.1	7.4		308.2			25.5	28	
STA. 38+525.43 - STA. 38+560.482 LT.	37.1		143									
STA. 38+526.65 - STA. 38+561.561 RT.	37.1		143									
STA. 38+560.48 - STA. 40+216.300 LT.		1694.5			458.5	203.9					1694.5	
STA. 38+560.48 - STA. 40+270.000 LT.	1326.3		5106	4.4						3634.6	1326.3	
STA. 38+561.56 - STA. 38+583.921 RT.								144.2				
STA. 38+560.48 - STA. 38+582.842 LT.								144.2				
STA. 38+561.56 - STA. 40+216.300 RT.		1694.5			458.5	203.9					1694.5	
STA. 38+561.56 - STA. 40+270.000 RT.	1326.3		5106	4.4						3633.4	1326.3	
STA. 40+000.00 (MEDIAN X-OVER)									50			
STA. 40+198.10 - STA. 40+216.300 LT.								144.2				
STA. 40+198.10 - STA. 40+216.300 RT.								144.2				
STA. 40+270.00 - STA. 40+486.000 LT.	167.5		645	0.6							167.5	
STA. 40+270.00 - STA. 40+486.000 RT.	167.5		645	0.6							167.5	
STA. 40+216.30 - STA. 40+486.000 LT.					84.5		1723.5					
STA. 40+216.30 - STA. 40+486.000 RT.					84.5		1723.5					
AS DETERMINED BY THE ENGINEER				79.8		583.4*						
TOTAL	6138.8	3389	23637	100	1111.3	991.2	37297.8	13128	576.8	50	10857.3	9453.6
USE	6139	3389	23637	100	1112	992*	37298	13128	577	50	10858	9454

*ADDITIONAL AGGREGATE SHOULDER QUANTITY ADDED FOR LOW EXISTING SHOULDERS THROUGHOUT PROJECT. QUANTITY ADDS 1" TO EXISTING SHOULDERS.

LOCATION	EACH
STA. 37+048.0	1
STA. 37+992.1	1
STA. 38+846.1	1
STA. 39+181.3	1
STA. 38+237.4	1
TOTAL	5

LOCATION	EACH
STA. 36+845, RT.	1
STA. 36+892, LT.	1
STA. 37+129, RT.	1
STA. 37+141, LT.	1
STA. 37+280, RT.	1
STA. 37+292, LT.	1
STA. 38+408, RT.	1
STA. 38+420, LT.	1
STA. 38+923, RT.	1
STA. 38+935, LT.	1
STA. 39+409, RT.	1
STA. 39+421, LT.	1
STA. 40+238, LT.	1
STA. 40+264, TL.	1
TOTAL	14

LOCATION	LINE 100 MM M7800355 METER
STA. 36+305.000, - STA 40+486.000	2091

LOCATION	SO M
STA. 37+250, RT	360
TOTAL	360

LOCATION	SLOPE WALL REMOVAL	SLOPE WALL 100 MM
	M5010465 SO M	M5110100 SO M
S. N. 057-0028 - S. N. 057-0029	0.4	0.4
S. N. 057-0024 - S. N. 057-0025	39.0	39.0
TOTAL	39.4	39.4
USE	40	40

*ADDITIONAL FILL OF 25 CU M MAY BE NEEDED BENEATH PROPOSED SLOPE WALL SECTIONS. ANY REQUIRED FILL WILL BE PAID FOR USING SECTION 109.04 OF THE STANDARD SPECIFICATIONS. AREAS FOR SLOPE WALL REPAIR ARE 3M x 3M, 3M x 3M, AND 3M x 7M.

LOCATION	METER
STA. 37+942.30, RT. - STA. 37+960.20, RT.	18
STA. 38+283.50, LT.	2
STA. 38+572.30, LT. - STA. 38+584.70, LT.	12
TOTAL	32

LOCATION	TEMPORARY CONCRETE BARRIER M7040100 METER	RELOCATE TEMPORARY CONCRETE BARRIER M7040200 METER
STA. 37+377.0, RT - 38+299.0, RT (STAGE I)	922	
STA. 38+130.4, LT - 38+623.0, LT (STAGE I)	493	
STA. 37+410.9, LT - 37+535.1, LT		124
STA. 37+412.8, RT - 37+537.2, RT		125
STA. 38+208.3, LT - 38+315.1, LT		107
STA. 38+210.8, RT. - 38+318.1, RT		107
STA. 37+330.0, RT - 38+318.0, RT (STAGE II)		988
STA. 37+432.0, LT - 37+522.0, LT (STAGE II)		90
STA. 38+233.6, LT - 38+439.1, LT (STAGE II)		206
TOTAL	1415	1747

LOCATION	METER	SO M
BEFORE STAGE 1		
STA. 37+375.0 - STA. 37+509.5 NB, EXIST. MARKING OUTSIDE EDGE	134.5	13.5
STA. 37+375.0 - STA. 37+509.5 NB, EXIST. SKIP DASH BETW. LANES	33.6	5.0
STA. 37+509.5 - STA. 38+044.0 NB, OUTSIDE EDGE	534.5	53.5
STA. 38+287.6 - STA. 38+625.0 NB, OUTSIDE EDGE	337.4	33.7
STA. 38+426.8 - STA. 38+625.0 SB, OUTSIDE EDGE	198.2	19.8
BEFORE STAGE 2		
STA. 34+950.0 - STA. 36+305.0 NB, STAGE 1 TAPER AND APPROACH	1355.0	135.5
STA. 38+125.0 - STA. 38+167.0 SB, RAMP D INSIDE EDGE	42.0	4.2
STA. 40+486.0 - STA. 41+915.0 SB, STAGE 1 TAPER AND APPROACH	1429.0	142.9
STAGE 2 WHITE		
STA. 34+400.0 - STA. 36+305.0 NB, STAGE 2 TAPER AND APPROACH	1905.0	190.5
STA. 36+305.0 - STA. 36+640.0 NB, OUTSIDE EDGE	335.0	33.5
STA. 36+640.0 - STA. 37+350.0 NB, SKIP DASH BETWEEN LANES	71.0	7.1
STA. 37+375.0 - STA. 37+509.5 NB, OUTSIDE EDGE	134.5	13.5
STA. 37+375.0 - STA. 38+044.0 NB, BETWEEN LANES	669.0	66.9
STA. 38+287.6 - STA. 38+625.0 NB, OUTSIDE EDGE	337.4	33.7
STA. 38+426.9 - STA. 38+623.0 SB, OUTSIDE EDGE	196.1	19.6
STA. 37+350.0 - STA. 38+575.0 NB, INSIDE EDGE	1225.0	122.5
STA. 37+915.6 - STA. 38+125.0 RAMP D LEFT EDGE	209.4	20.9
STA. 38+100.0 - STA. 38+625.0 SB, INSIDE EDGE	525.0	52.5
STA. 37+375.0 - STA. 38+625.0 NB, STAGE 1 BARRIER/CENTER STRIPE	1250.0	125.0
STA. 38+130.4 - STA. 38+625.0 SB, STAGE 1 BARRIER STRIPE	494.6	49.5
STA. 37+350.0 - STA. 38+625.0 NB, STAGE 2 BARRIER/CENTER STRIPE	1275.0	127.5
STA. 38+233.6 - STA. 38+625.0 NB, STAGE 2 CENTER STRIPE	391.4	39.1
STA. 36+500.0 - STA. 36+550.0 RAMP A, STAGE 2, LEFT	50.0	5.0
STA. 36+515.0 - STA. 36+630.0 RAMP A, STAGE 2, RIGHT	115.0	11.5
STA. 37+060.0 - STA. 37+240.0 RAMP C, STAGE 2, RIGHT	180.0	18.0
STA. 37+150.0 - STA. 37+245.0 RAMP C, STAGE 2, LEFT	95.0	9.5
STA. 37+915.6 - STA. 38+125.0 RAMP D, STAGE 2, LEFT	209.4	20.9
STA. 38+125.0 - STA. 38+150.0 RAMP D, STAGE 2, LEFT	25.0	2.5
STA. 38+125.0 - STA. 38+233.6 RAMP D, STAGE 2, RIGHT	108.6	10.9
STA. 40+486.0 - STA. 43+000.0 SB, STAGE 2 TAPER AND APPROACH	2514.0	251.4
TOTAL	1639.6	1640
USE	1640	

LOCATION	RAMP SO M
STA. 36+305.000, LT.	11.7
STA. 36+305.000, RT.	11.7
STA. 37+410.902, LT.	11.7
STA. 37+412.956, RT.	11.7
STA. 37+535.440, LT.	11.7
STA. 37+537.555, RT.	11.7
STA. 38+208.330, LT.	11.7
STA. 38+210.808, RT.	11.7
STA. 38+315.520, LT.	11.7
STA. 38+317.995, RT.	11.7
STA. 40+486.000, LT.	11.7
STA. 40+486.000, RT.	11.7
TOTAL	140.4
USE	141

LOCATION	PAVED DITCH REMOVAL M4405000 METER	PAVED DITCH TY. B-15 M6063400 METER	PAVED DITCH TY. B-45 M6063440 METER
STA. 38+888.0, LT.	4	4	---
STA. 38+943, LT.	10	10	---
STA. 38+983.0, LT.	6	6	---
STA. 39+063.0, LT.	6	6	---
STA. 40+165.6, RT.	82	---	82
TOTAL	108	26	82

SCHEDULE OF QUANTITIES
F.A.I. 55
SECTION (57-4)RS-3 & I
MCLEAN COUNTY

F.A.I. RTE.	SECTION	COUNTY	TOTAL SHEETS	SHEET NO.
55	•	McLEAN	87	26
STA.		TO STA.		
FED. ROAD DIST. NO.		ILLINOIS FED. AID PROJECT		

• (57-4)RS-3 & I

LOCATION	GUARDRAIL			
	GUARDRAIL MARKERS	TERMINAL MARKER - DIRECT APPLIED	STEEL PLATE BEAM GUARDRAIL TY. A	GUARDRAIL REMOVAL
	78200405	78201000	M6300100	M6320030
	EACH	EACH	METER	METER
STA. 37+049.591, RT.	1	---	---	---
STA. 37+319.668, RT. - STA. 37+413.550, RT.	4	---	---	---
STA. 37+334.868, RT. - STA. 37+399.634, RT.	---	---	64.77	---
STA. 37+336.333, RT. - STA. 37+416.571, RT.	---	---	---	80.45
STA. 37+349.727, RT.	1	---	---	---
STA. 37+434.315, RT.	1	---	---	---
STA. 37+502.545, LT.	1	---	---	---
STA. 37+530.648, LT. - STA. 37+610.976, LT.	---	---	---	80.52
STA. 37+535.148, LT. - STA. 37+628.269, LT.	4	---	---	---
STA. 37+548.302, LT. - STA. 37+613.069, LT.	---	---	64.77	---
STA. 37+581.934, LT.	1	---	---	---
STA. 38+033.271, RT.	1	---	---	---
STA. 38+117.680, RT. - STA. 38+211.563, RT.	4	---	---	---
STA. 38+132.880, RT. - STA. 38+197.647, RT.	---	---	64.77	---
STA. 38+135.134, RT. - STA. 38+215.295, RT.	---	---	---	80.39
STA. 38+195.797, RT. - STA. 38+210.801, RT.	1	---	15.0	15.0
STA. 38+231.728, RT.	1	---	---	---
STA. 38+235.837, LT.	1	---	---	---
STA. 38+310.742, LT. - STA. 38+391.317, LT.	---	---	---	80.80
STA. 38+314.382, LT. - STA. 38+408.265, LT.	4	---	---	---
STA. 38+328.298, LT. - STA. 38+393.065, LT.	---	---	64.77	---
STA. 38+400.879, RT. - STA. 38+525.242, RT.	5	---	---	---
STA. 38+416.079, RT. - STA. 38+511.326, RT.	---	---	95.25	---
STA. 38+480.769, RT. - STA. 38+529.951, RT.	---	---	---	50.06
STA. 38+513.505, RT. - STA. 38+517.318, RT.	---	---	---	3.81
STA. 38+517.318, RT.	1	---	---	---
STA. 38+557.150, LT. - STA. 38+606.303, LT.	---	---	---	49.97
STA. 38+559.241, LT.	1	---	---	---
STA. 38+562.089, LT. - STA. 38+686.452, LT.	5	---	---	---
STA. 38+569.344, LT. - STA. 38+573.157, LT.	---	---	---	3.81
STA. 38+576.005, LT. - STA. 38+671.252, LT.	---	---	95.25	---
STA. 38+633.431, LT.	1	---	---	---
STA. 40+155.956, RT.	1	---	---	---
STA. 40+330.874, LT.	1	---	---	---
⊙ EACH TRAFFIC BARRIER TY. 1 SPECIAL	---	13	---	---
TOTAL	40	13	464.58	444.81
USE			464.82	445

X0301894 - REMOVE AND REINSTALL CONCRETE HEADWALL FOR PIPE DRAINS	
LOCATION	EACH
STA. 39+279.5, RT.	1
STA. 39+731.2, LT.	1
STA. 40+036.8, RT.	1
TOTAL	3

Z0030150 - IMPACT ATTENUATOR (NON-REDIRECTIVE) TEST LEVEL 3	
LOCATION	EACH
STA. 36+845, RT.	1
STA. 36+892, LT.	1
STA. 37+129, RT.	1
STA. 37+141, LT.	1
STA. 37+280, RT.	1
STA. 37+292, LT.	1
STA. 38+408, RT.	1
STA. 38+420, LT.	1
STA. 38+923, RT.	1
STA. 38+935, LT.	1
STA. 39+409, RT.	1
STA. 39+421, LT.	1
STA. 40+238, LT.	1
STA. 40+264, LT.	1
TOTAL	14

Z0030350 - IMPACT ATTENUATOR, RELOCATE (NON-REDIRECTIVE), TEST LEVEL 3	
LOCATION	EACH
STA. 37+330, RT	1
STA. 38+439, LT	1
TOTAL	2

TEMPORARY PAVEMENT MARKING, 100 MM	
LOCATION	M7030220
	METER
STAGE 1 WHITE	
STA. 36+305.0 - STA. 36+640.0 NB, OUTSIDE EDGE	335.0
STA. 36+640.0 - STA. 37+350.0 NB, SKIP DASH BETWEEN LANES	71.0
STA. 37+350.0 - STA. 37+509.5 NB, OUTSIDE EDGE	159.5
STA. 37+350.0 - STA. 38+044.0 NB, BETWEEN LANES	694.0
STA. 38+287.6 - STA. 38+625.0 NB, OUTSIDE EDGE	337.4
STA. 38+625.0 - STA. 40+486.0 NB, OUTSIDE EDGE	1861.0
STA. 36+305.0 - STA. 36+625.0 SB, OUTSIDE EDGE	320.0
STA. 38+426.9 - STA. 38+700.0 SB, OUTSIDE EDGE	273.1
STA. 38+700.0 - STA. 40+486.0 SB, OUTSIDE EDGE	1786.0
STAGE 2 YELLOW	
STA. 36+305.0 - STA. 37+350.0 NB, INSIDE EDGE	1045.0
STA. 37+350.0 - STA. 38+575.0 NB, INSIDE EDGE	1225.0
STA. 38+575.0 - STA. 40+486.0 NB, INSIDE EDGE	1911.0
STA. 37+915.6 - STA. 38+125.0 RAMP D LEFT EDGE	209.4
STA. 36+305.0 - STA. 38+100.0 SB, INSIDE EDGE	1795.0
STA. 38+100.0 - STA. 38+625.0 SB, INSIDE EDGE	525.0
STA. 38+625.0 - STA. 40+486.0 SB, INSIDE EDGE	1861.0
STAGE 2 WHITE	
STA. 36+305.0 - STA. 38+100.0 SB, OUTSIDE EDGE	320.0
STA. 36+305.0 - STA. 38+100.0 SB, OUTSIDE EDGE	1230.0
TOTAL WHITE	7387.0
TOTAL YELLOW	8571.4
TOTAL	15958.4
USE	15959

POLYURETHANE MATERIAL	
LOCATION	CU M
STA. 38+300, RT. (EAST BRIDGE APPROACH PAVEMENT DRIVING LANE SN 057-0026)	3
TOTAL	3

Z0030250 - IMPACT ATTENUATOR, TEMPORARY (NON-REDIRECTIVE), TEST LEVEL 3		
LOCATION	STAGE 1	STAGE 2
	EACH	EACH
STA. 37+377, RT	1	
STA. 37+522, LT		1
STA. 38+623, LT	1	
TOTAL		3

PAVEMENT MARKING				
LOCATION	POLYUREA PAVEMENT MARKING, TYPE II			
	LINE 100 MM	LINE 100 MM	LINE 200 MM	LINE 300 MM
	METER	METER	METER	METER
STA. 36+305.000, LT.- STA. 36+630.100, LT.	325.1			
STA. 36+305.000, RT.- STA. 36+485.000, RT.	180.0			
STA. 36+305.000, LT. - STA. 40+486.000, LT.		4181		
STA. 36+305.000, RT. - STA. 40+486.000, RT.		4181		
STA. 36+485.000, RT. - STA. 36+650.210, RT.			165.2	
STA. 36+864.880, LT. - STA. 38+332.800, LT.	1467.9			
STA. 36+924.990, LT. - STA. 37+249.000, LT.				177.3
STA. 37+293.990, LT. - STA. 38+104.000, LT.				113.8
STA. 37+412.790, RT. - STA. 37+658.220, RT.			245.4	
STA. 37+541.000, RT. - STA. 37+649.000, RT.				100.0
STA. 37+658.220, RT. - STA. 37+950.820, RT.	292.6			
STA. 37+950.820, RT. - STA. 38+086.890, RT.			136.1	
STA. 38+124.990, LT. - STA. 38+280.990, LT.				95.6
STA. 38+358.500, RT. - STA. 40+486.000 RT.	2127.5			
STA. 38+424.580, LT. - STA. 40+486.000, LT.	2061.4			
TOTAL	6454.5	8362	546.7	486.7
USE			547	487

F.A.I. RTE.	SECTION	COUNTY	TOTAL SHEETS	SHEET NO.
55		McLEAN	87	27
STA. 36+305		TO STA. 37+00		
FED. ROAD DIST. NO.		ILLINOIS		FED. AID PROJECT

• (57-4)RS-3 & I

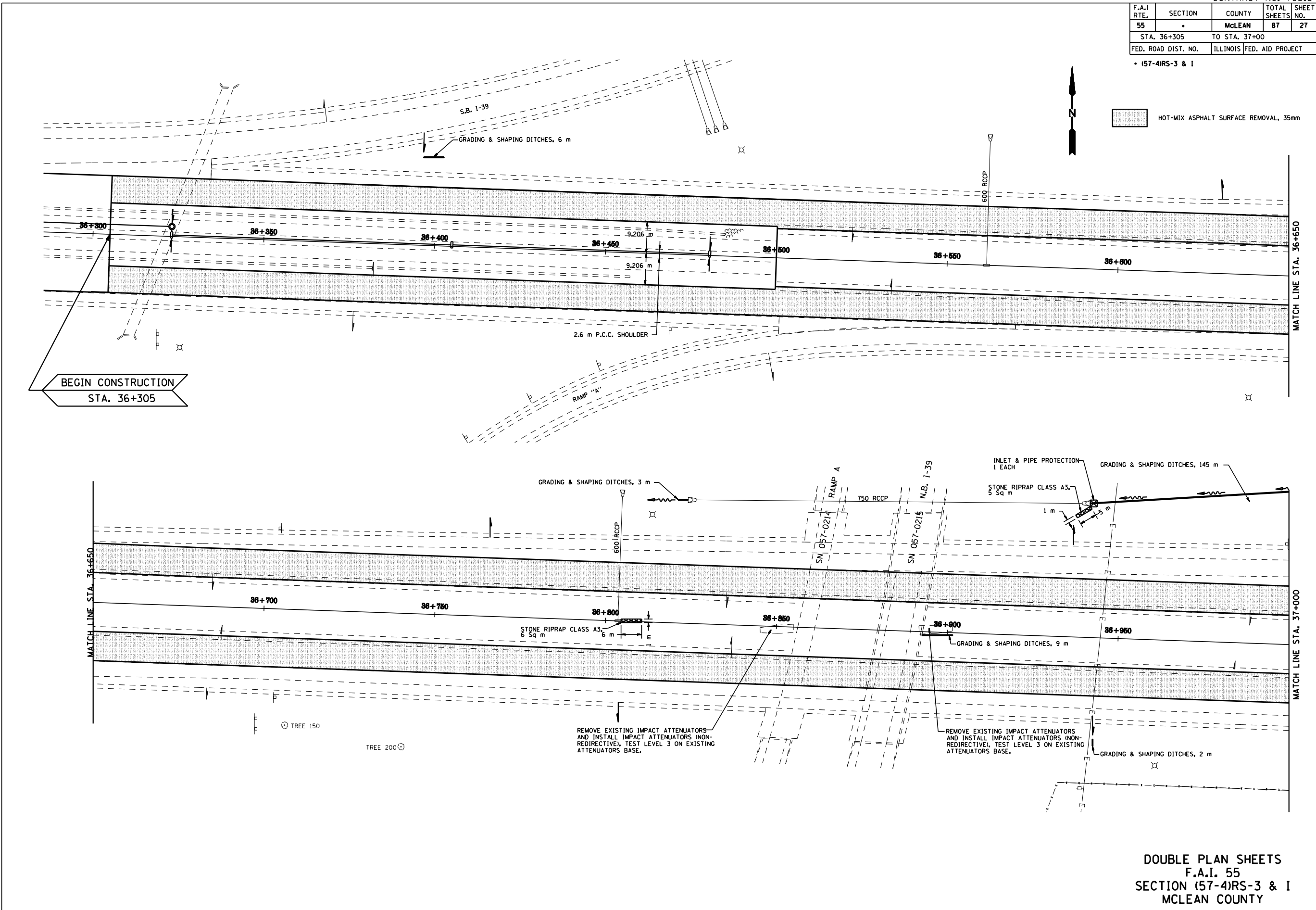

DOUBLE PLAN SHEETS
 F.A.I. 55
 SECTION (57-4)RS-3 & I
 McLEAN COUNTY

F.A.I. RTE.	SECTION	COUNTY	TOTAL SHEETS	SHEET NO.
55		McLEAN	87	28
STA. 37+000 TO STA. 37+700		FED. ROAD DIST. NO. ILLINOIS FED. AID PROJECT		
(57-4)RS-3 & 1				

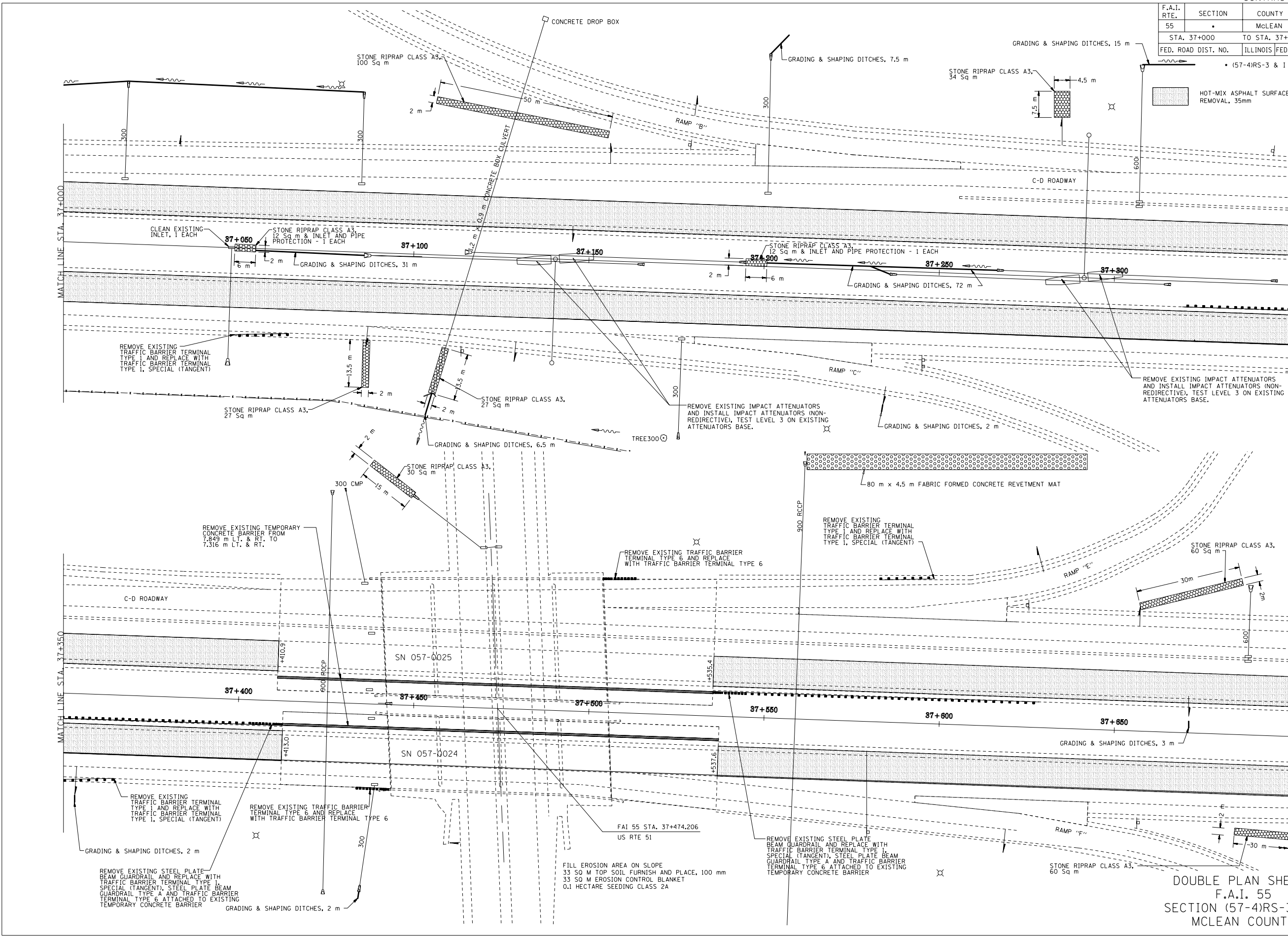

DOUBLE PLAN SHEETS
 F.A.I. 55
 SECTION (57-4)RS-3 & 1
 McLEAN COUNTY

FILL EROSION AREA ON SLOPE
 33 SO M TOP SOIL FURNISH AND PLACE, 100 mm
 33 SO M EROSION CONTROL BLANKET
 0.1 HECTARE SEEDING CLASS 2A

REMOVE EXISTING STEEL PLATE BEAM GUARDRAIL AND REPLACE WITH TRAFFIC BARRIER TERMINAL TYPE 1, SPECIAL (TANGENT), STEEL PLATE BEAM GUARDRAIL TYPE A AND TRAFFIC BARRIER TERMINAL TYPE 6 ATTACHED TO EXISTING TEMPORARY CONCRETE BARRIER

REMOVE EXISTING STEEL PLATE BEAM GUARDRAIL AND REPLACE WITH TRAFFIC BARRIER TERMINAL TYPE 1, SPECIAL (TANGENT), STEEL PLATE BEAM GUARDRAIL TYPE A AND TRAFFIC BARRIER TERMINAL TYPE 6 ATTACHED TO EXISTING TEMPORARY CONCRETE BARRIER

REMOVE EXISTING TEMPORARY CONCRETE BARRIER FROM 7.849 M LT. & RT. TO 7.316 M LT. & RT.

REMOVE EXISTING TRAFFIC BARRIER TERMINAL TYPE 6 AND REPLACE WITH TRAFFIC BARRIER TERMINAL TYPE 6

REMOVE EXISTING TRAFFIC BARRIER TERMINAL TYPE 1 AND REPLACE WITH TRAFFIC BARRIER TERMINAL TYPE 1, SPECIAL (TANGENT)

REMOVE EXISTING IMPACT ATTENUATORS AND INSTALL IMPACT ATTENUATORS NON-REDIRECTIVE, TEST LEVEL 3 ON EXISTING ATTENUATORS BASE.

REMOVE EXISTING TRAFFIC BARRIER TERMINAL TYPE 1 AND REPLACE WITH TRAFFIC BARRIER TERMINAL TYPE 1, SPECIAL (TANGENT)

REMOVE EXISTING IMPACT ATTENUATORS AND INSTALL IMPACT ATTENUATORS NON-REDIRECTIVE, TEST LEVEL 3 ON EXISTING ATTENUATORS BASE.

F.A.I. RTE.	SECTION	COUNTY	TOTAL SHEETS	SHEET NO.
55		McLEAN	87	29
STA. 37+700		TO STA. 38+400		
FED. ROAD DIST. NO.		ILLINOIS		FED. AID PROJECT

• (57-4)RS-3 & I

HOT-MIX ASPHALT SURFACE REMOVAL, 35mm

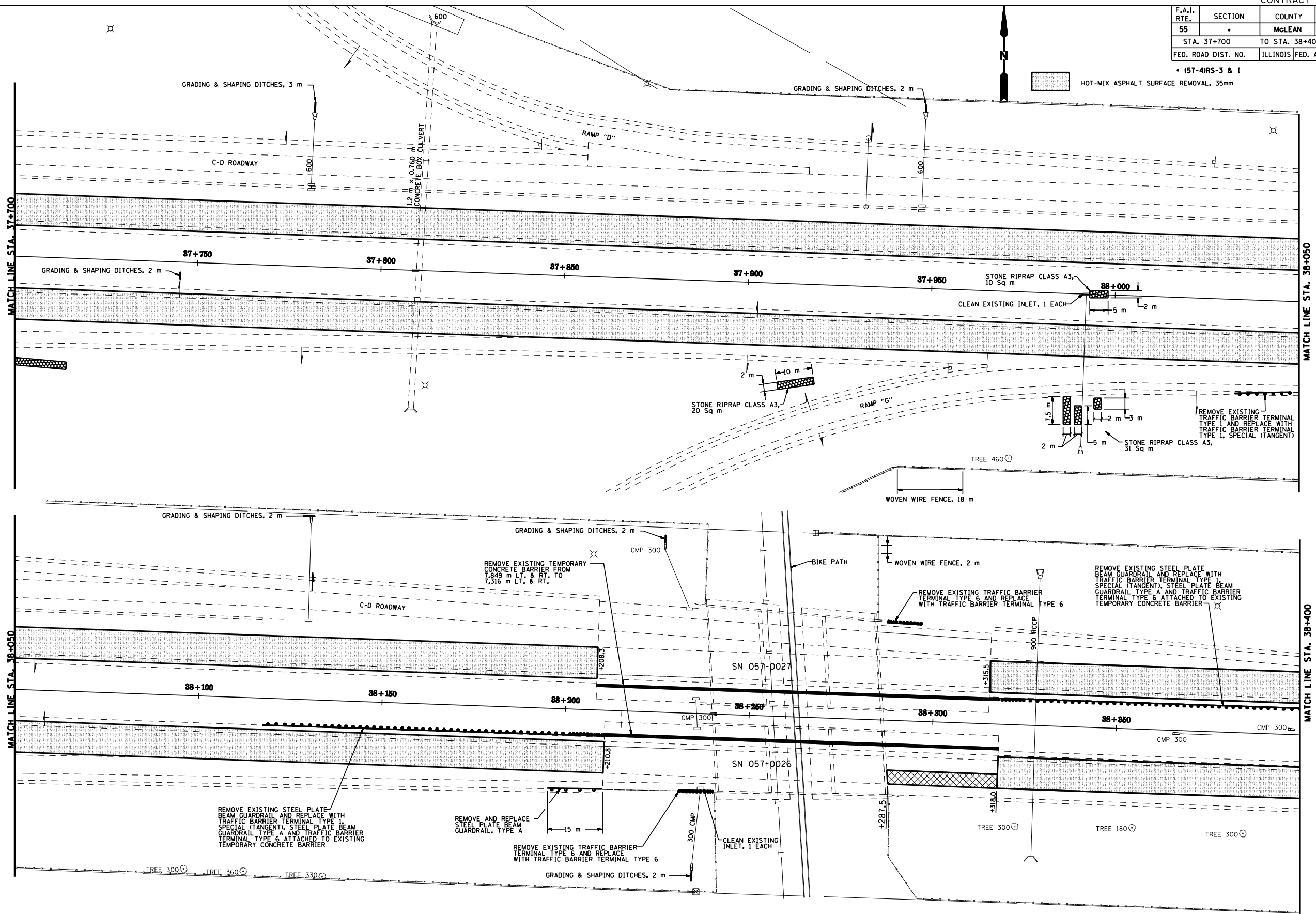





PRESSURE GROUT BELOW EXISTING APPROACH PAVEMENT TO CORRECT SETTLEMENT

DOUBLE PLAN SHEETS
 F.A.I. 55
 SECTION (57-4) RS-3 & I
 McLEAN COUNTY

F.A.I. RTE.	SECTION	COUNTY	TOTAL SHEETS	SHEET NO.
55		McLEAN	87	30
STA. 38+400 TO STA. 39+100				
FED. ROAD DIST. NO.		ILLINOIS FED. AID PROJECT		

CENTERLINE CURVE DATA
 $\Delta = 03^{\circ}00'45''$
 $R = 6985.787m$
 $T = 183.684m$
 $L = 367.283m$
 $P.C. STA. 38+479.440$
 $P.I. STA. 38+663.124$
 $P.T. STA. 38+846.723$

• (57-4)RS-3 & I

-  HOT-MIX ASPHALT SURFACE REMOVAL, 35mm
-  HOT-MIX ASPHALT SURFACE REMOVAL BRIDGE DECK REPLACE WITH POLYMERIZED HOT-MIX ASPHALT SURFACE COURSE, MIX E N105 38mm
-  HOT-MIX ASPHALT SURFACE REMOVAL VARIABLE DEPTH
-  HOT-MIX ASPHALT SURFACE REMOVAL, 110mm

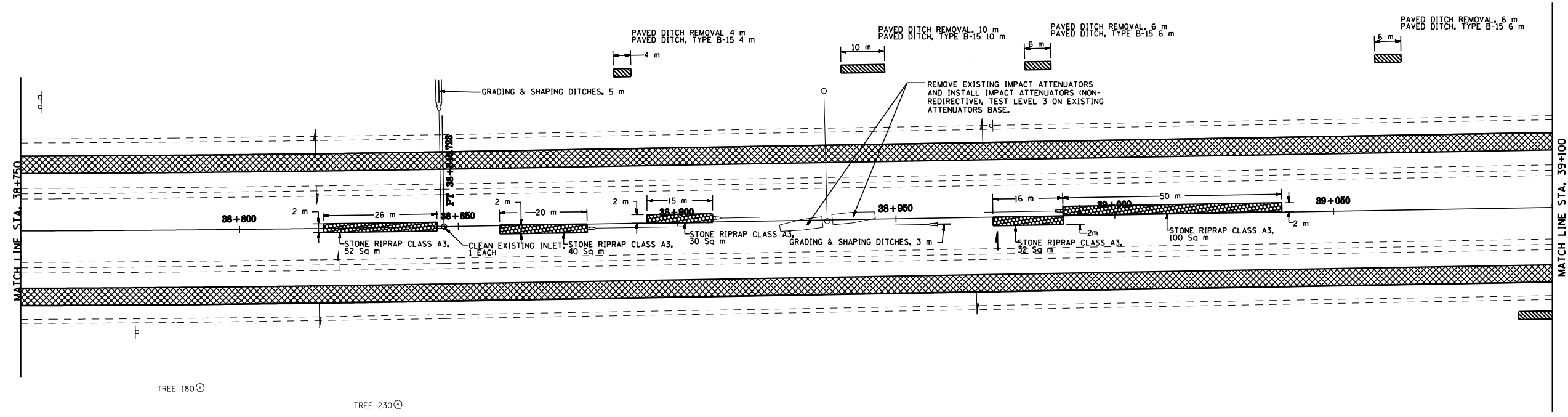
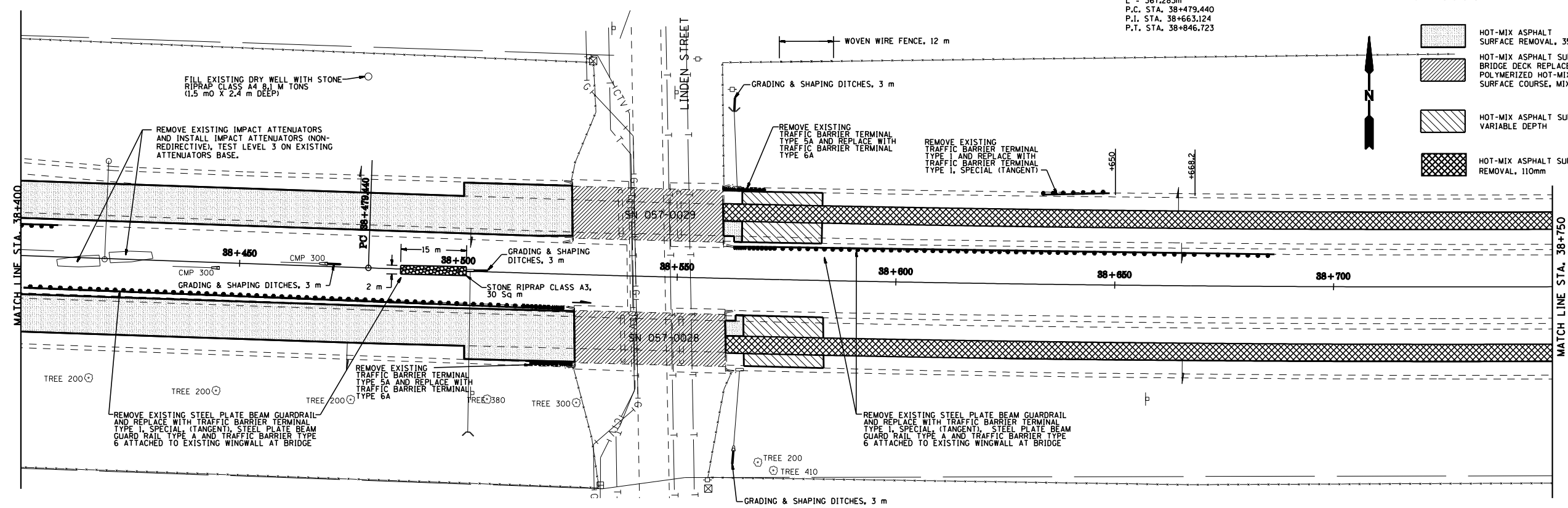

F.A.I. RTE.	SECTION	COUNTY	TOTAL SHEETS	SHEET NO.
55		McLEAN	87	31
STA. 39+100		TO STA. 39+800		
FED. ROAD DIST. NO.		ILLINOIS FED. AID PROJECT		

• (57-4)RS-3 & I

HOT-MIX ASPHALT SURFACE REMOVAL, 110mm

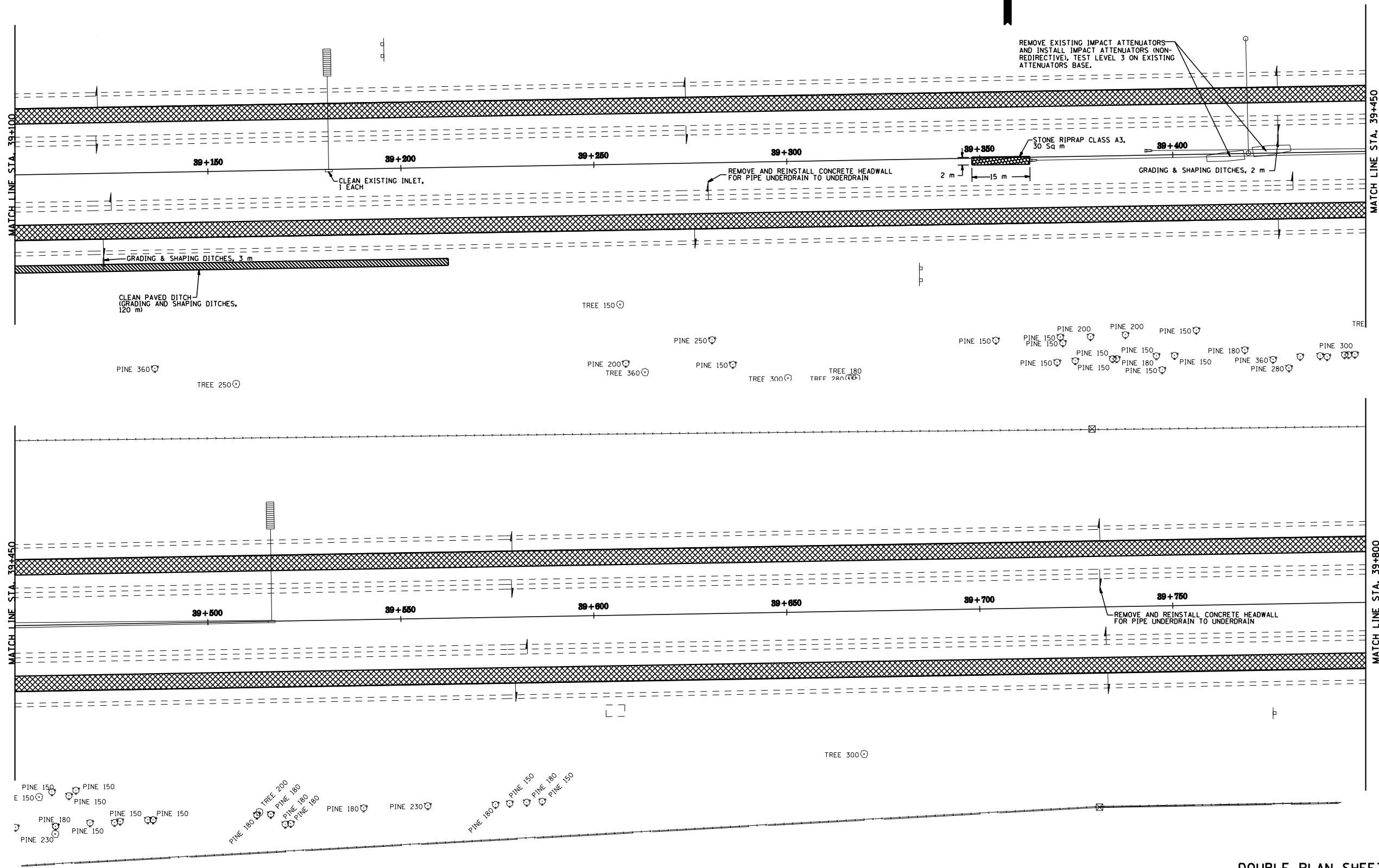

DOUBLE PLAN SHEETS
 F.A.I. 55
 SECTION (57-4)RS-3 & I
 McLEAN COUNTY

F.A.I. RTE.	SECTION	COUNTY	TOTAL SHEETS	SHEET NO.
55		McLEAN	87	32
STA. 39+800		TO STA. 40+486		
FED. ROAD DIST. NO.		ILLINOIS FED. AID PROJECT		



- HOT-MIX ASPHALT SURFACE REMOVAL, 35mm
- HOT-MIX ASPHALT SURFACE REMOVAL VARIABLE DEPTH
- HOT-MIX ASPHALT SURFACE REMOVAL, 110mm

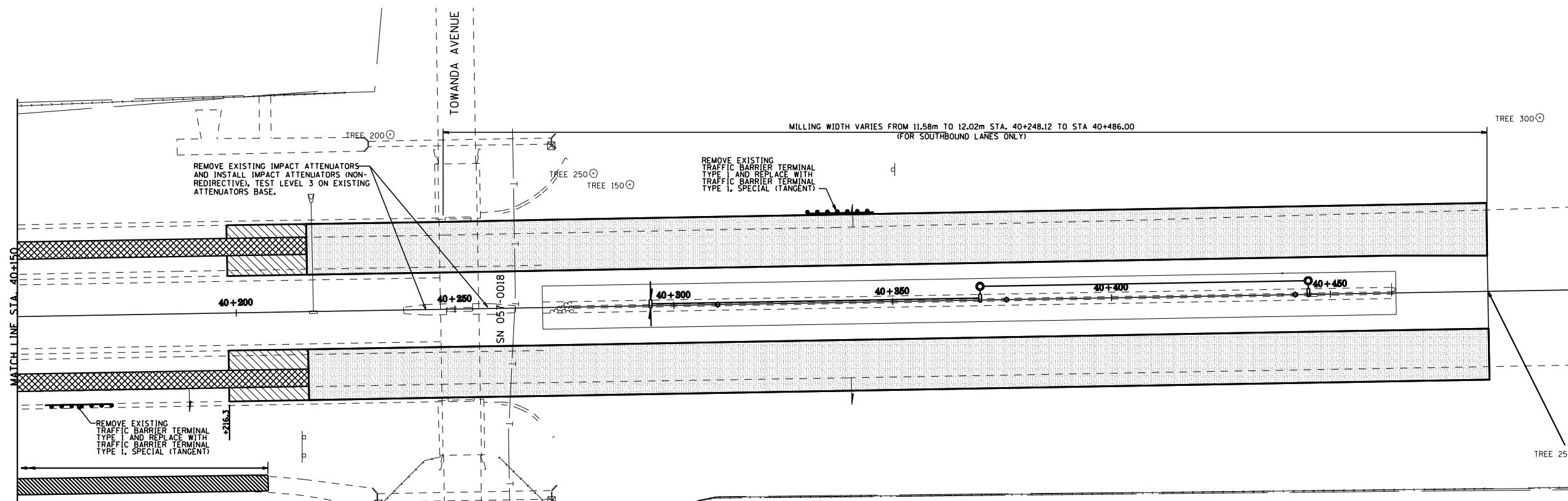
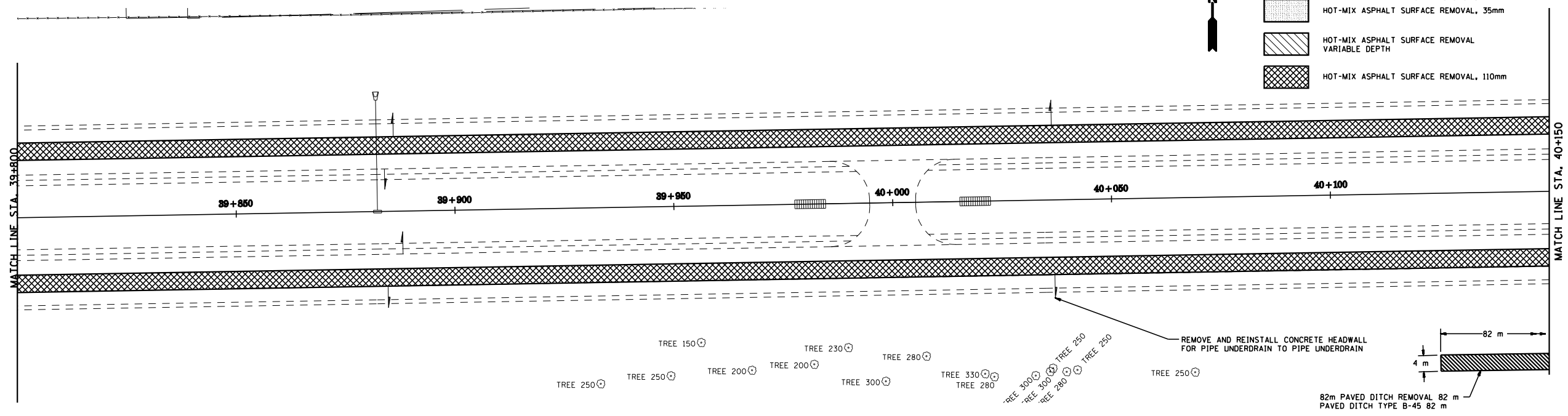

END CONSTRUCTION
STA. 40+486

DOUBLE PLAN SHEETS
F.A.I. 55
SECTION (57-4)RS-3 & I
MCLEAN COUNTY

F.A.I. RTE.	SECTION	COUNTY	TOTAL SHEETS	SHEET NO.
55		McLEAN	87	33
STA. 36+305		TO STA. 37+00		
FED. ROAD DIST. NO.		ILLINOIS FED. AID PROJECT		

• (57-4)RS-3 & I

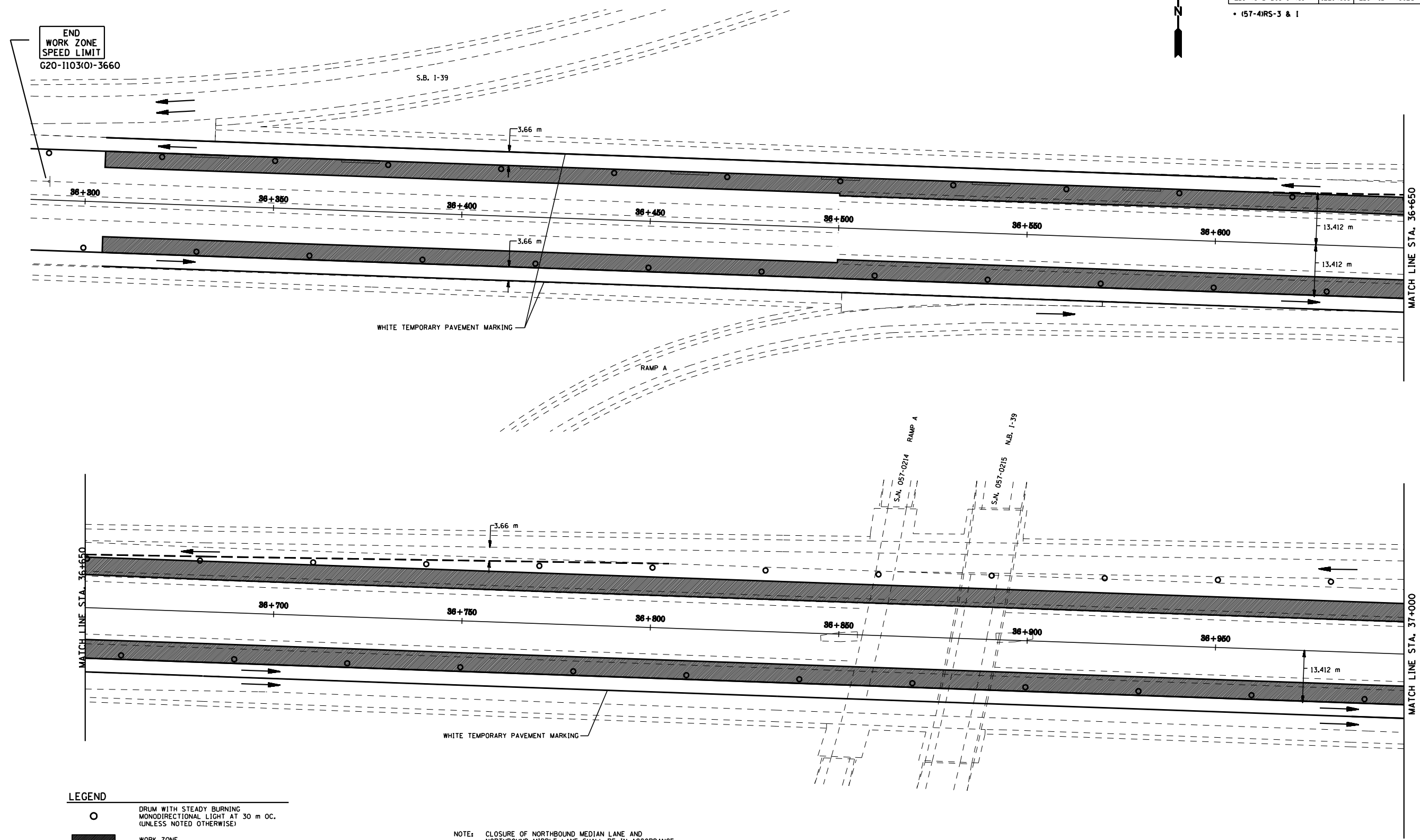
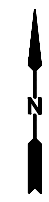

- LEGEND**
- DRUM WITH STEADY BURNING MONODIRECTIONAL LIGHT AT 30 m OC. (UNLESS NOTED OTHERWISE)
 - ▨ WORK ZONE
 - TRAFFIC

NOTE: CLOSURE OF NORTHBOUND MEDIAN LANE AND NORTHBOUND MIDDLE LANE SHALL BE IN ACCORDANCE WITH HIGHWAY STANDARD 701446 AND 701400 THE TAPER TO BEGIN THE MEDIAN LANE CLOSURE SHALL BEGIN AT STA. 34+950

STAGE CONSTRUCTION DETAILS - STAGE 1
 F.A.I. 55
 SECTION (57-4)RS-3 & I
 MCLEAN COUNTY

F.A.I. RTE.	SECTION	COUNTY	TOTAL SHEETS	SHEET NO.
55		McLEAN	87	34
STA. 37+000		TO STA. 37+700		
FED. ROAD DIST. NO.		ILLINOIS FED. AID PROJECT		

(57-4)RS-3 & 1

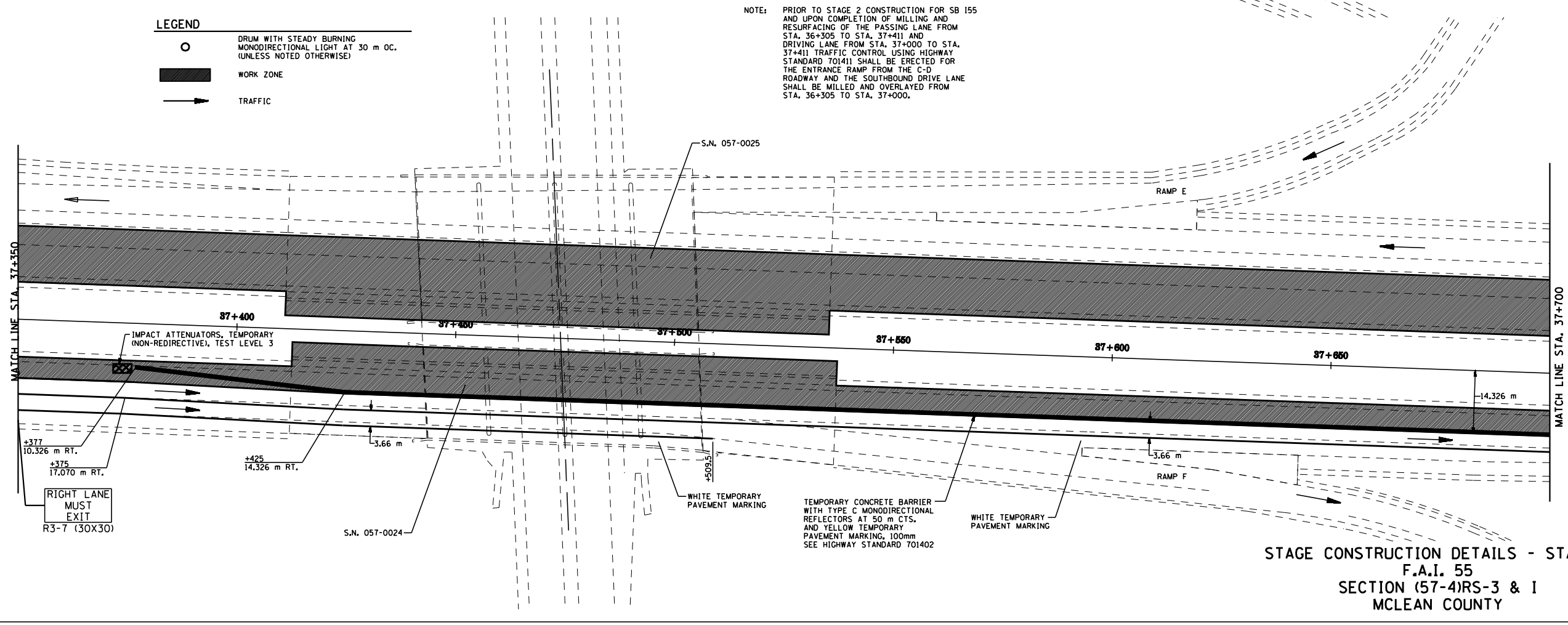
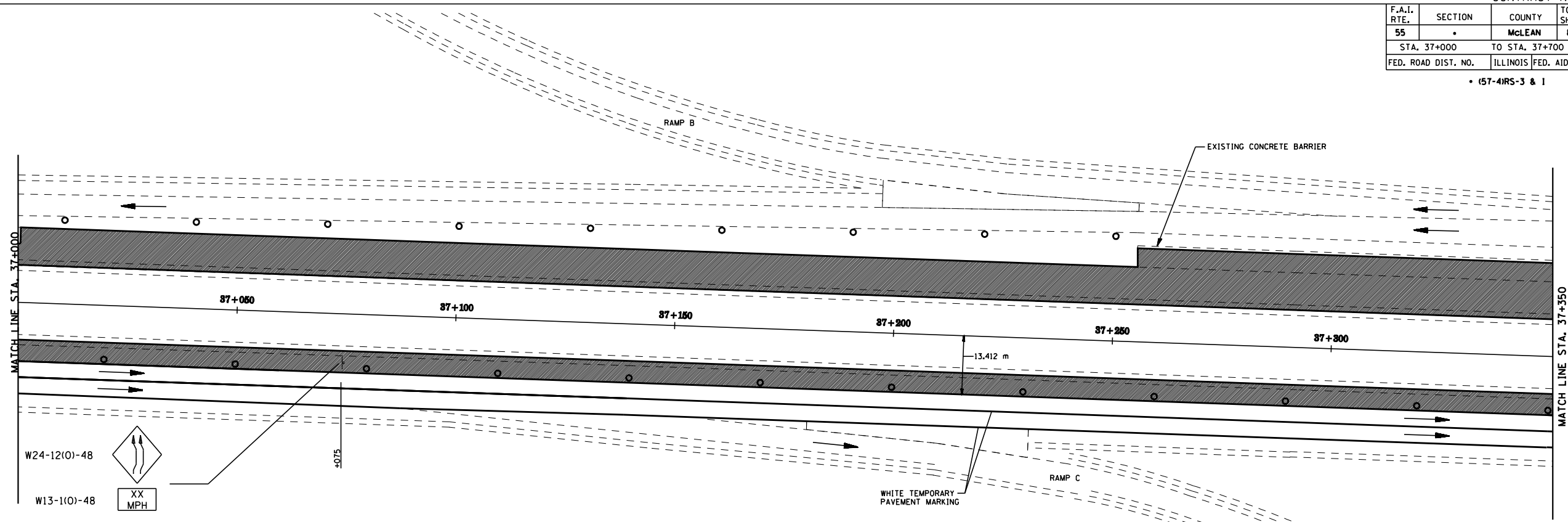
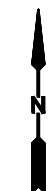

STAGE CONSTRUCTION DETAILS - STAGE 1
 F.A.I. 55
 SECTION (57-4)RS-3 & 1
 McLEAN COUNTY

F.A.I. RTE.	SECTION	COUNTY	TOTAL SHEETS	SHEET NO.
55		McLEAN	87	35
STA. 37+700		TO STA. 38+400		
FED. ROAD DIST. NO.		ILLINOIS	FED. AID PROJECT	

• (57-4)RS-3 & I

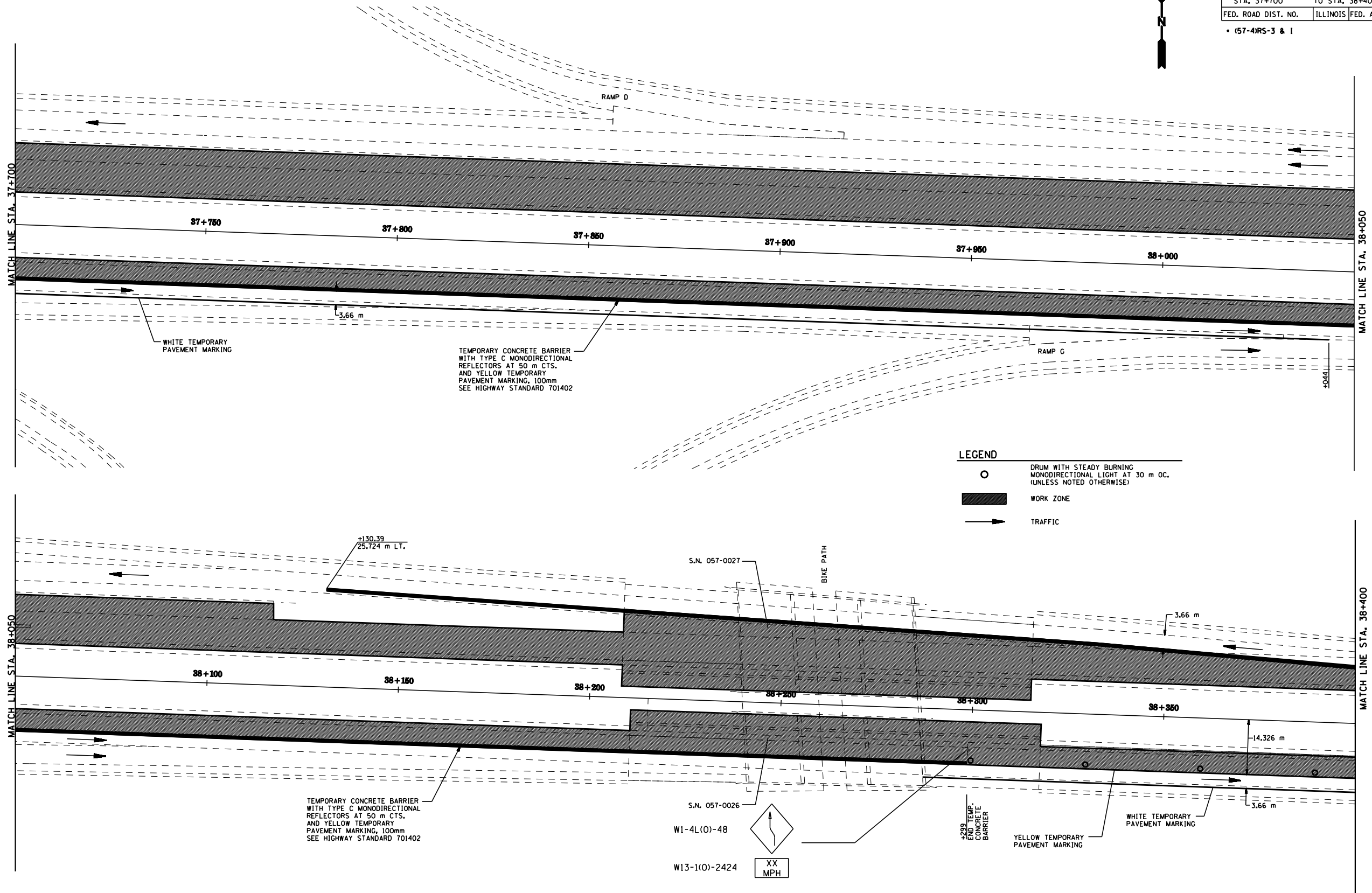

LEGEND

- DRUM WITH STEADY BURNING MONODIRECTIONAL LIGHT AT 30 m OC. (UNLESS NOTED OTHERWISE)
- WORK ZONE
- TRAFFIC

TEMPORARY CONCRETE BARRIER WITH TYPE C MONODIRECTIONAL REFLECTORS AT 50 m CTS. AND YELLOW TEMPORARY PAVEMENT MARKING, 100mm SEE HIGHWAY STANDARD 701402

S.N. 057-0026
W1-4L(O)-48

S.N. 057-0027
W13-1(O)-2424

END TEMP. CONCRETE BARRIER
YELLOW TEMPORARY PAVEMENT MARKING
WHITE TEMPORARY PAVEMENT MARKING

STAGE CONSTRUCTION DETAILS - STAGE 1
F.A.I. 55
SECTION (57-4)RS-3 & I
MCLEAN COUNTY

F.A.I. RTE.	SECTION	COUNTY	TOTAL SHEETS	SHEET NO.
55		McLEAN	87	36
STA. 38+400		TO STA. 39+100		
FED. ROAD DIST. NO.		ILLINOIS FED. AID PROJECT		

• (57-4)RS-3 & I

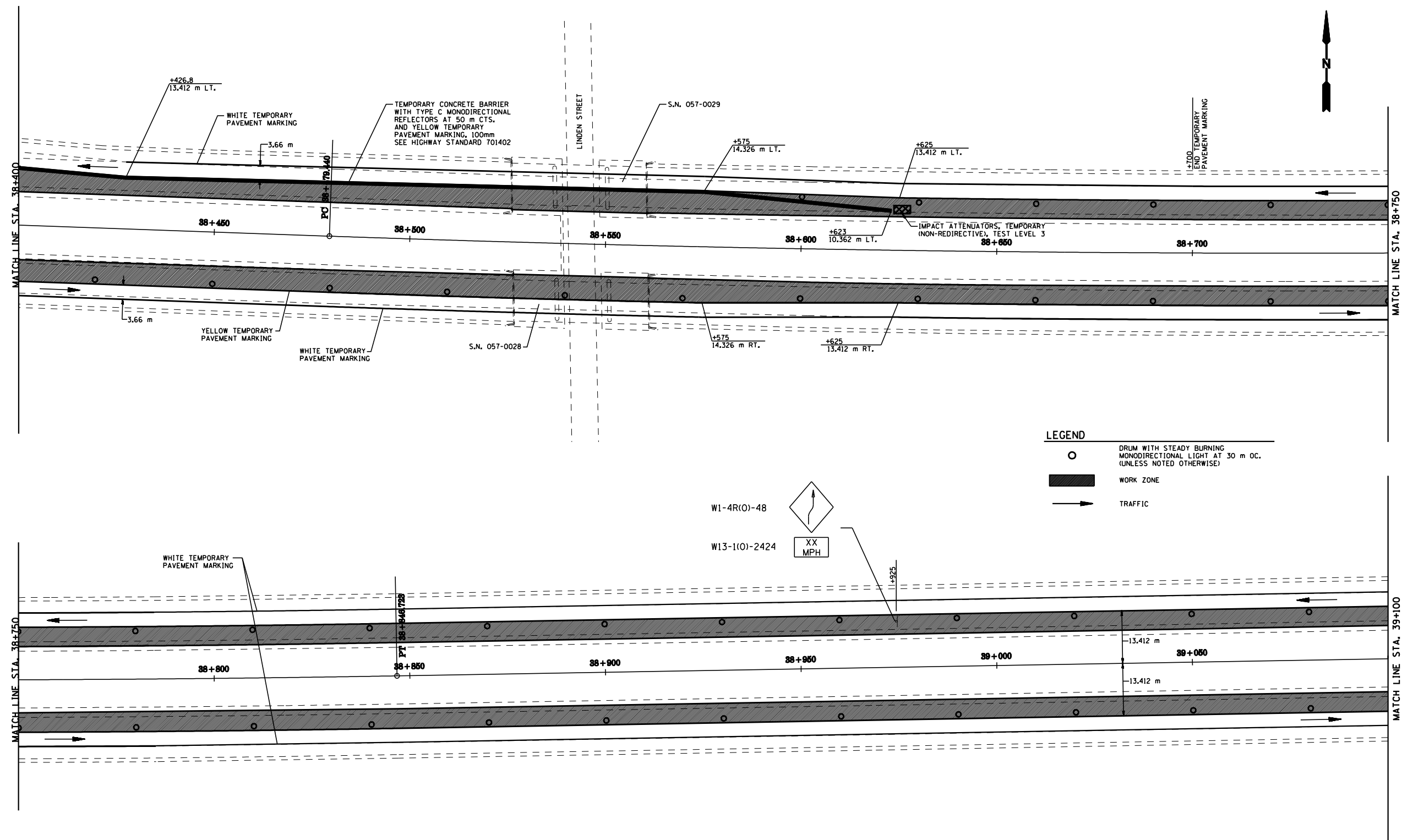

STAGE CONSTRUCTION DETAILS - STAGE 1
 F.A.I. 55
 SECTION (57-4)RS-3 & I
 McLEAN COUNTY

F.A.I. RTE.	SECTION	COUNTY	TOTAL SHEETS	SHEET NO.
55		McLEAN	87	37
STA. 39+100		TO STA. 39+800		
FED. ROAD DIST. NO.		ILLINOIS FED. AID PROJECT		

• (57-4)RS-3 & I

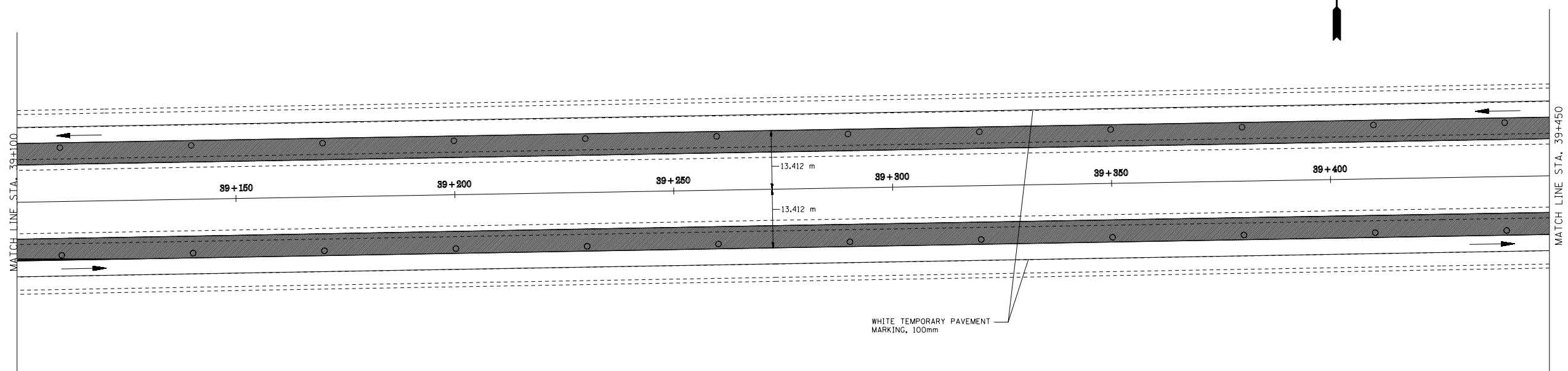

WHITE TEMPORARY PAVEMENT MARKING, 100mm

LEGEND

- DRUM WITH STEADY BURNING MONODIRECTIONAL LIGHT AT 30 m OC. (UNLESS NOTED OTHERWISE)
- WORK ZONE
- TRAFFIC

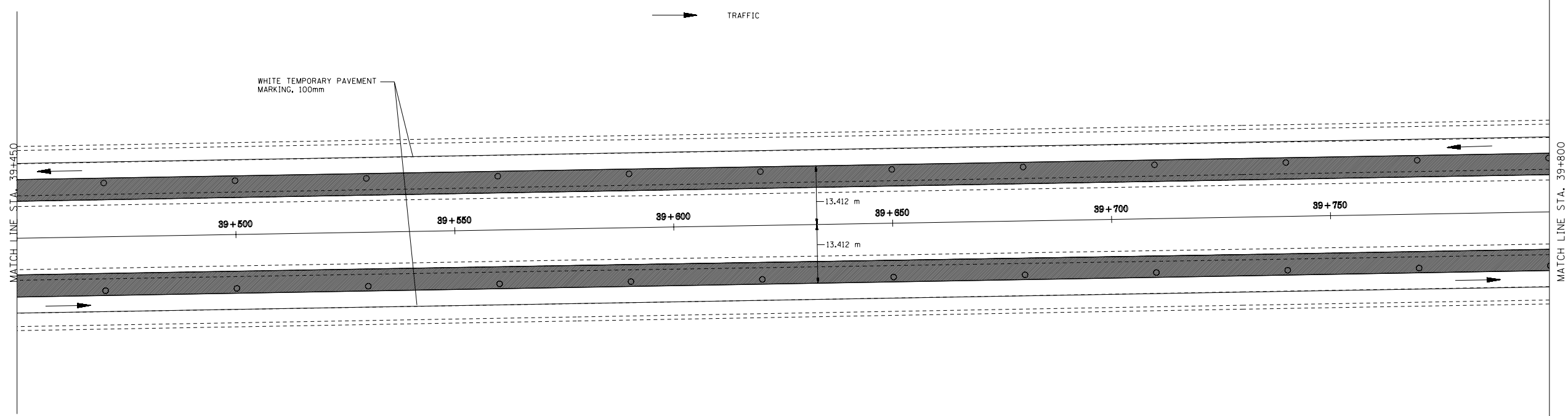

WHITE TEMPORARY PAVEMENT MARKING, 100mm

F.A.I. RTE.	SECTION	COUNTY	TOTAL SHEETS	SHEET NO.
55		McLEAN	87	38
STA. 39+800		TO STA. 40+486		
FED. ROAD DIST. NO.		ILLINOIS	FED. AID PROJECT	

• (57-4)RS-3 & 1

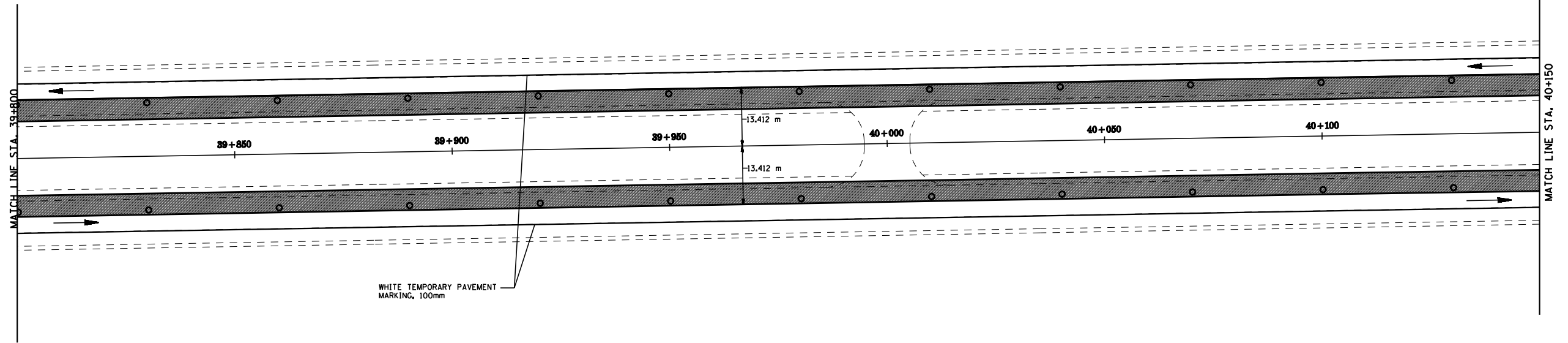
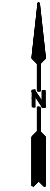

- LEGEND**
- DRUM WITH STEADY BURNING MONODIRECTIONAL LIGHT AT 30 m OC. (UNLESS NOTED OTHERWISE)
 - ▨ WORK ZONE
 - TRAFFIC

NOTE: CLOSURE OF SOUTHBOUND MEDIAN LANE AND SOUTHBOUND MIDDLE LANE SHALL BE IN ACCORDANCE WITH HIGHWAY STANDARD 701446 AND 701400 THE TAPER TO CLOSE THE SOUTHBOUND MEDIAN LANE SHALL BEGIN AT STA. 41+915.

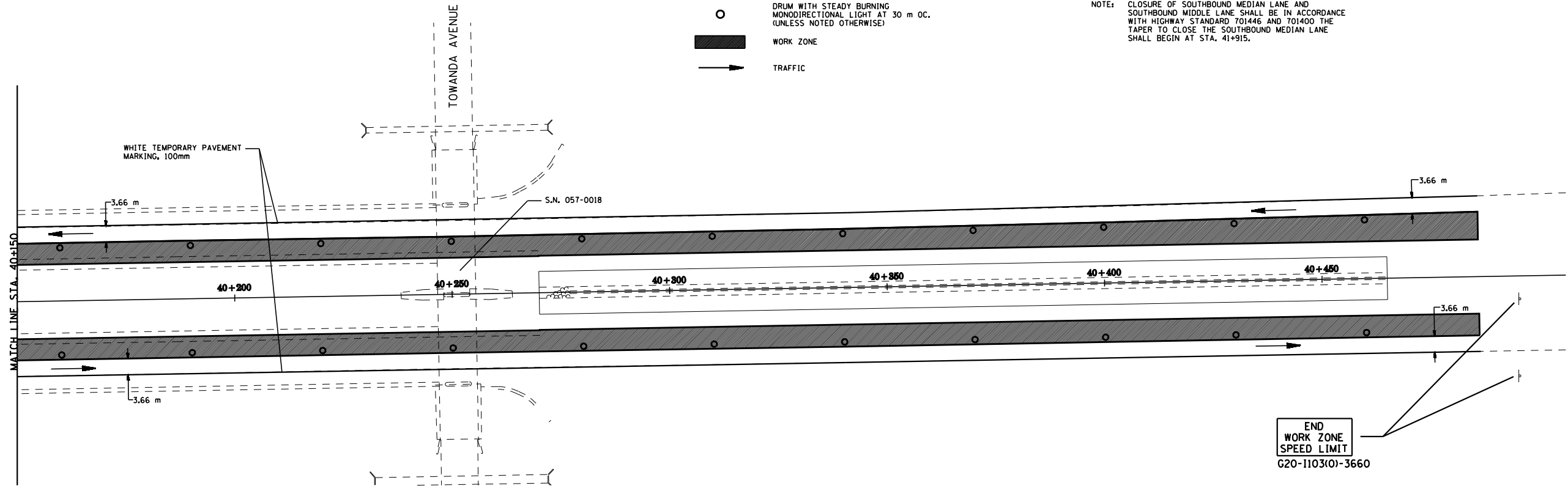

STAGE CONSTRUCTION DETAILS - STAGE 1
 F.A.I. 55
 SECTION (57-4)RS-3 & 1
 McLEAN COUNTY

F.A.I. RTE.	SECTION	COUNTY	TOTAL SHEETS	SHEET NO.
55		McLEAN	87	39
STA. 36+305		TO STA. 37+00		
FED. ROAD DIST. NO.		ILLINOIS FED. AID PROJECT		

• (57-4)RS-3 & I

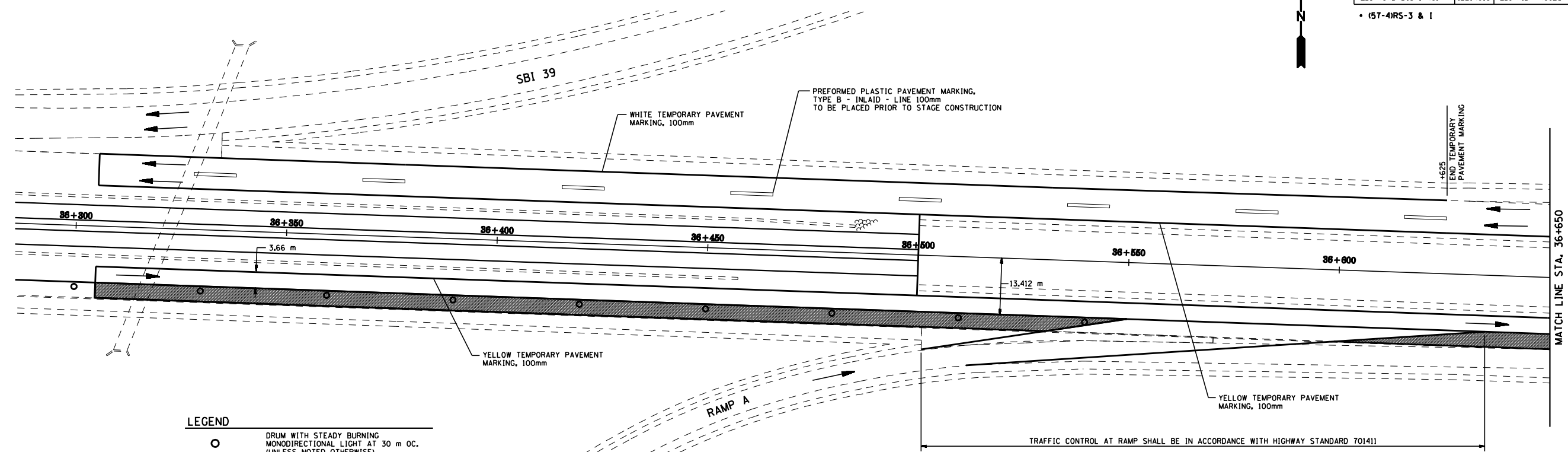
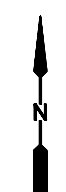

LEGEND

- DRUM WITH STEADY BURNING MONODIRECTIONAL LIGHT AT 30 m OC. (UNLESS NOTED OTHERWISE)
- WORK ZONE
- TRAFFIC

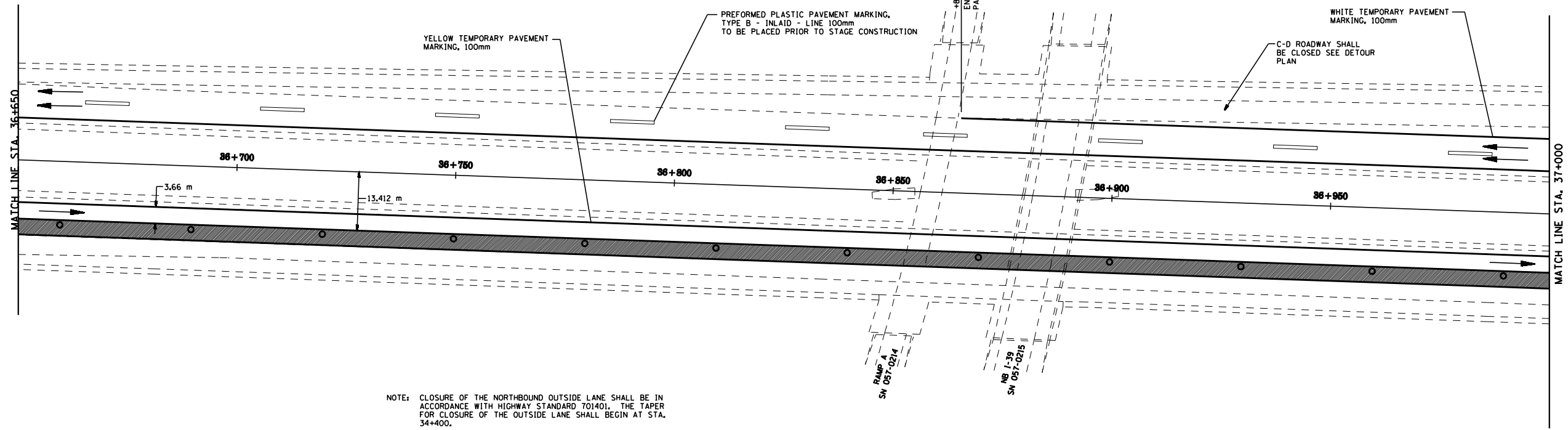

NOTE: CLOSURE OF THE NORTHBOUND OUTSIDE LANE SHALL BE IN ACCORDANCE WITH HIGHWAY STANDARD 701401. THE TAPER FOR CLOSURE OF THE OUTSIDE LANE SHALL BEGIN AT STA. 34+400.

HIGHWAY STANDARD 701411 SHALL BE USED AT THE ENTRANCE RAMP FROM 174 AND THE EXIT RAMP TO 139.

STAGE CONSTRUCTION DETAILS - STAGE 2
 F.A.I. 55
 SECTION (57-4)RS-3 & I
 MCLEAN COUNTY

F.A.I. RTE.	SECTION	COUNTY	TOTAL SHEETS	SHEET NO.
55		McLEAN	87	40
STA. 37+000		TO STA. 37+700		
FED. ROAD DIST. NO.		ILLINOIS FED. AID PROJECT		

(57-4IRS-3 & 1

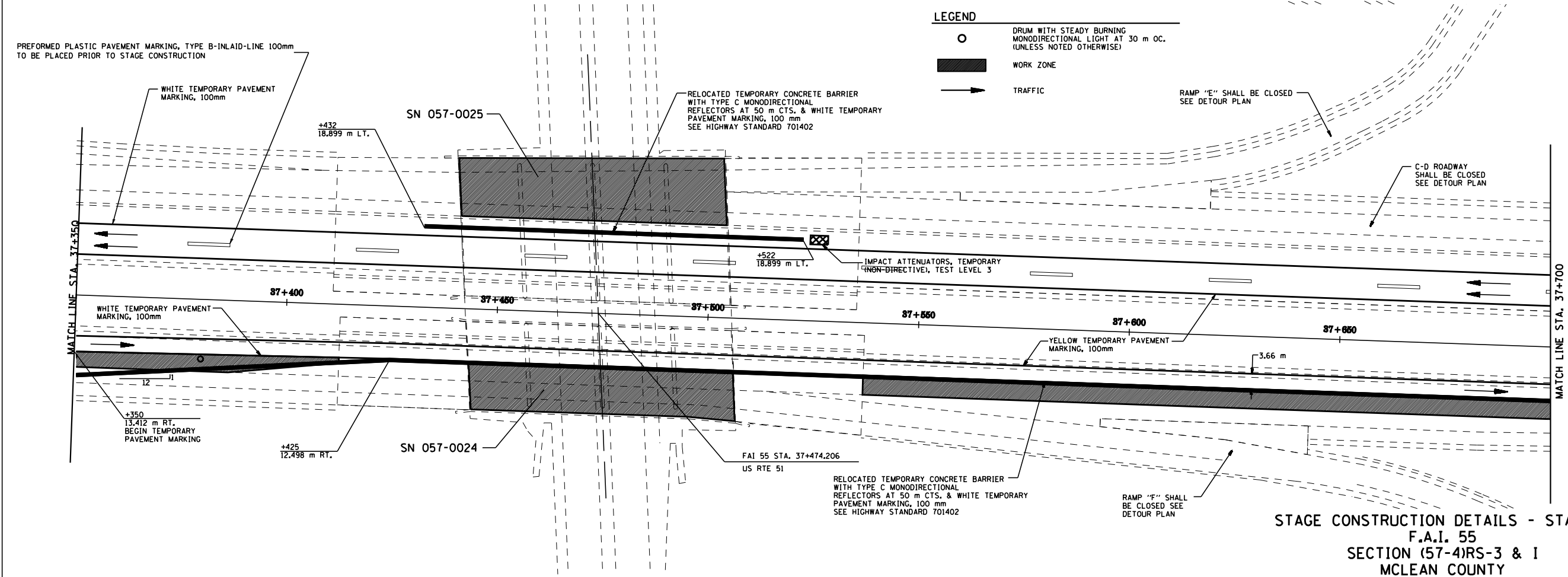
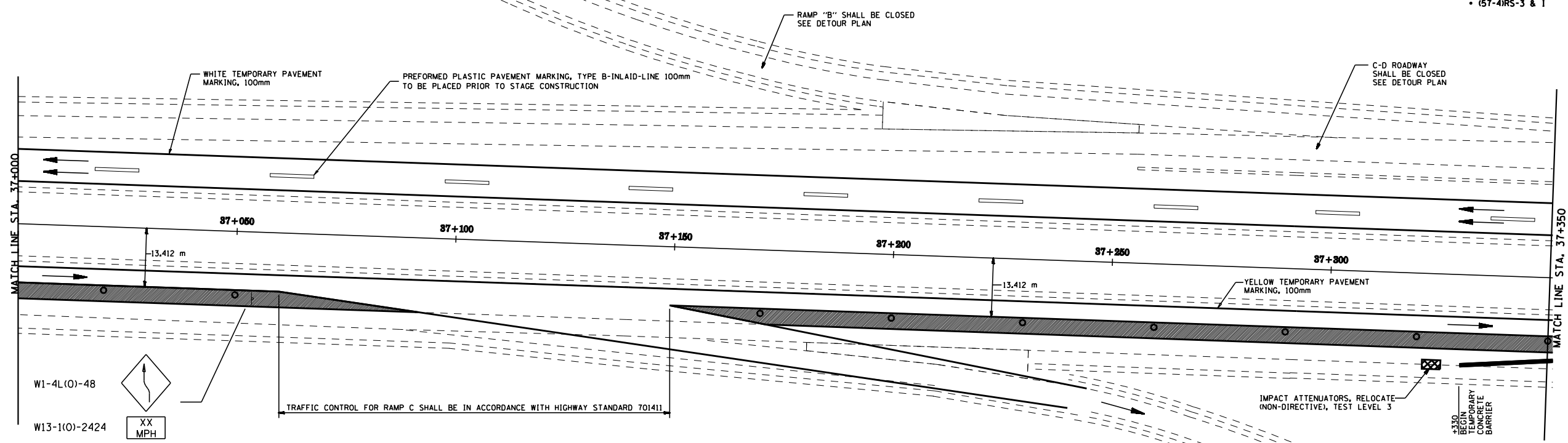

- LEGEND**
- DRUM WITH STEADY BURNING MONODIRECTIONAL LIGHT AT 30 m OC. (UNLESS NOTED OTHERWISE)
 - ▨ WORK ZONE
 - TRAFFIC

STAGE CONSTRUCTION DETAILS - STAGE 2
 F.A.I. 55
 SECTION (57-4IRS-3 & 1
 McLEAN COUNTY

F.A.I. RTE.	SECTION	COUNTY	TOTAL SHEETS	SHEET NO.
55		McLEAN	87	41
STA. 37+700		TO STA. 38+400		
FED. ROAD DIST. NO.		ILLINOIS		FED. AID PROJECT

• (57-4)RS-3 & I

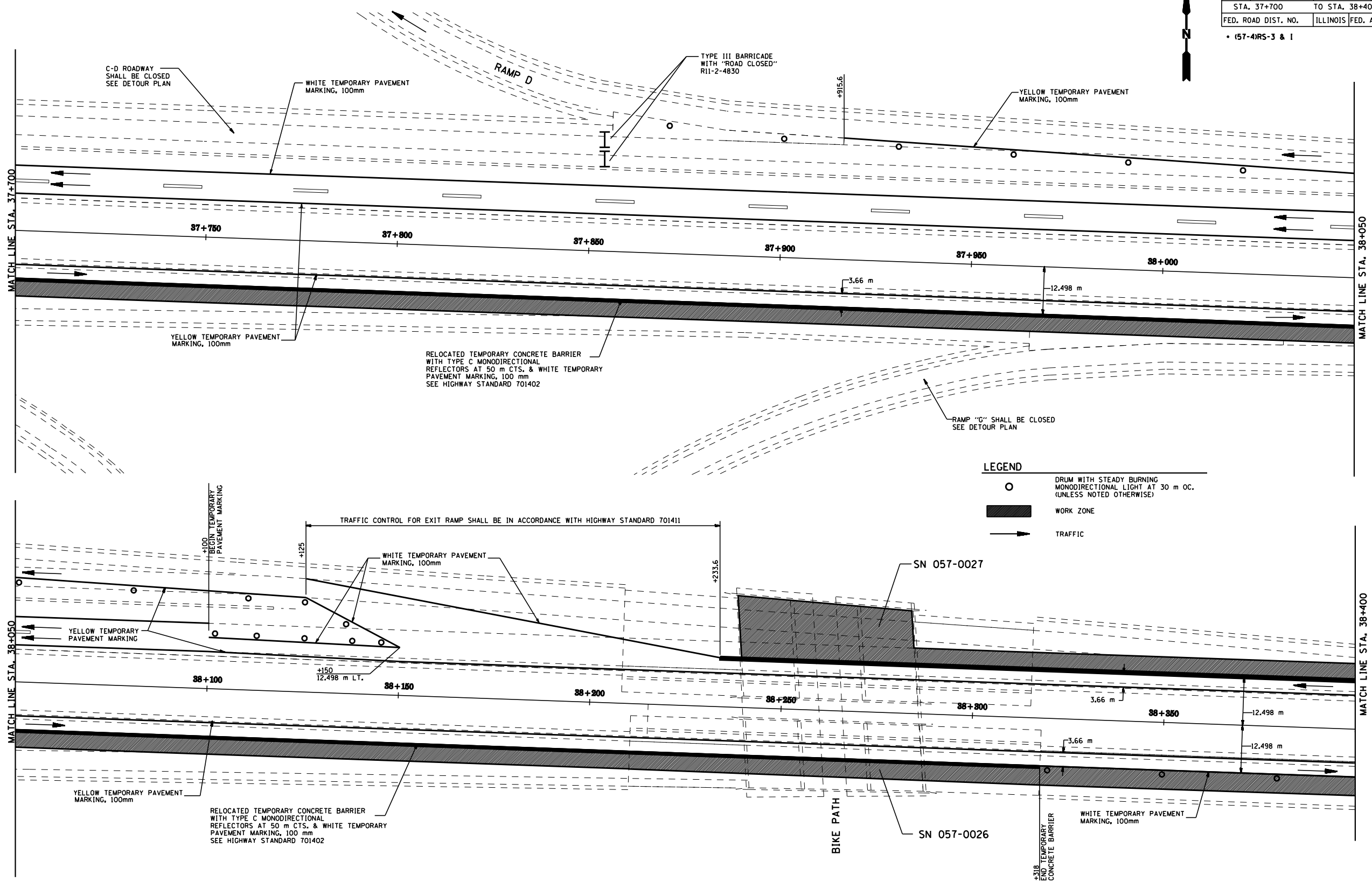

LEGEND

- DRUM WITH STEADY BURNING MONODIRECTIONAL LIGHT AT 30 m OC. (UNLESS NOTED OTHERWISE)
- WORK ZONE
- TRAFFIC

STAGE CONSTRUCTION DETAILS - STAGE 2
 F.A.I. 55
 SECTION (57-4)RS-3 & I
 McLEAN COUNTY

F.A.I. RTE.	SECTION	COUNTY	TOTAL SHEETS	SHEET NO.
55		McLEAN	87	42
STA. 38+400		TO STA. 39+100		
FED. ROAD DIST. NO.		ILLINOIS		FED. AID PROJECT

• (57-4)RS-3 & I

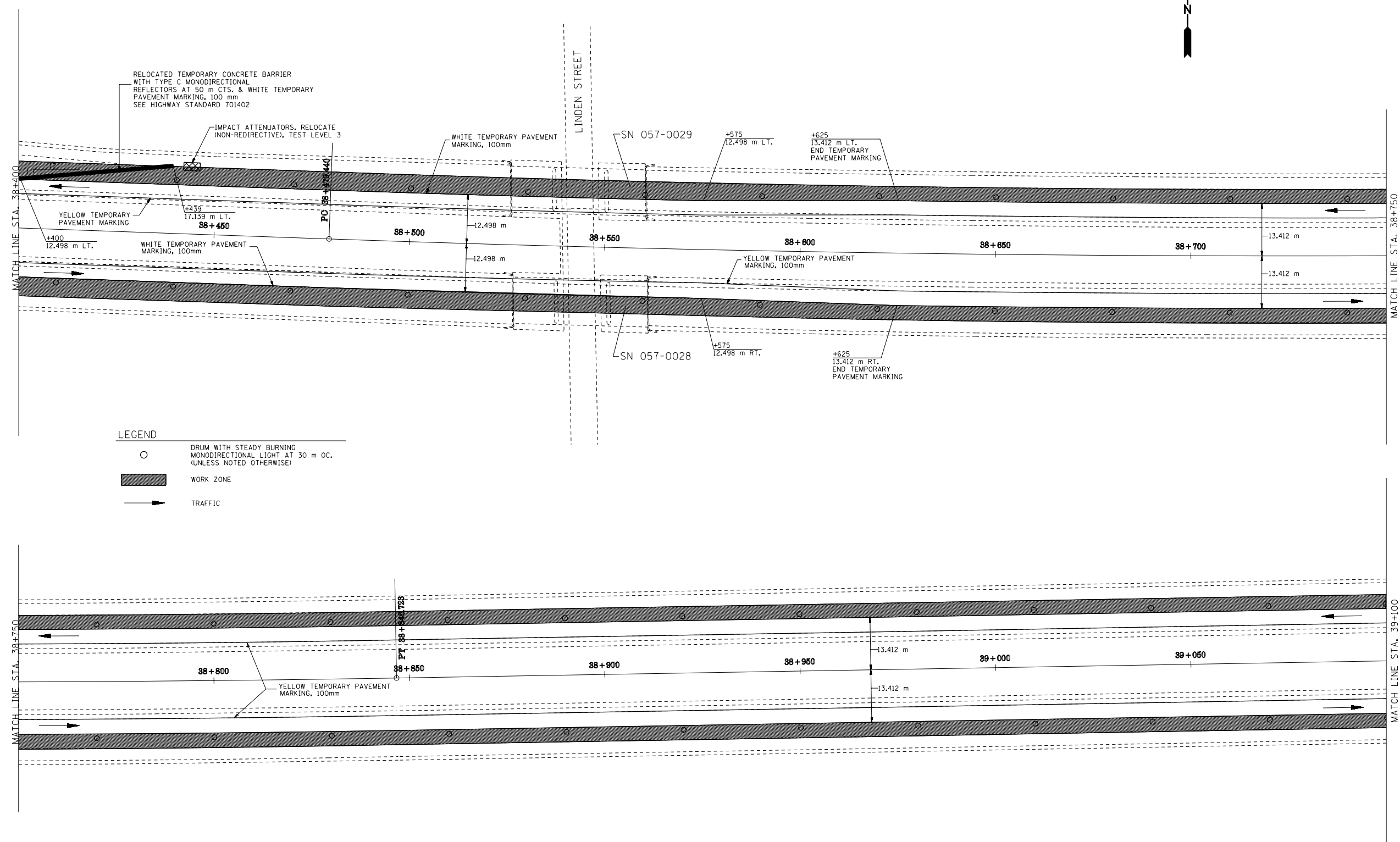

F.A.I. RTE.	SECTION	COUNTY	TOTAL SHEETS	SHEET NO.
55		McLEAN	87	43
STA. 39+100		TO STA. 39+800		
FED. ROAD DIST. NO.		ILLINOIS	FED. AID PROJECT	

• (57-4)RS-3 & I

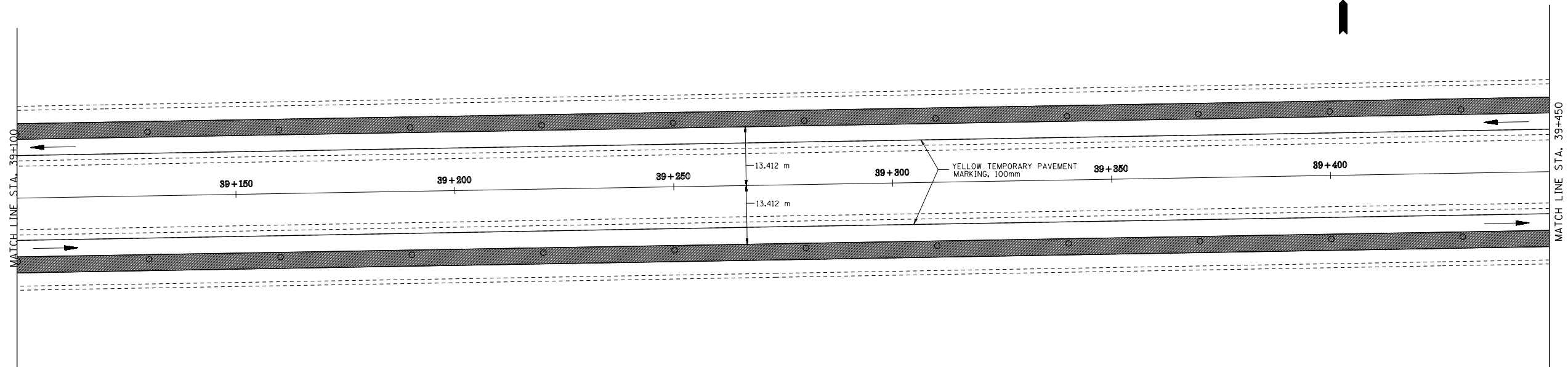

LEGEND

- DRUM WITH STEADY BURNING MONODIRECTIONAL LIGHT AT 30 m OC. (UNLESS NOTED OTHERWISE)
- WORK ZONE
- TRAFFIC

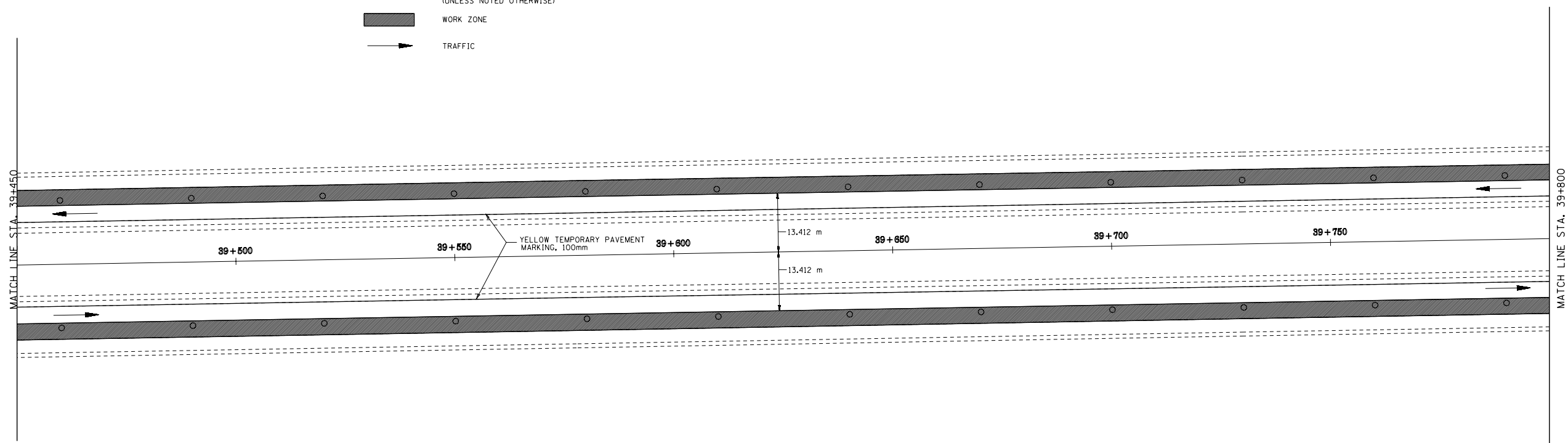

STAGE CONSTRUCTION DETAILS - STAGE 2
 F.A.I. 55
 SECTION (57-4)RS-3 & I
 McLEAN COUNTY

F.A.I. RTE.	SECTION	COUNTY	TOTAL SHEETS	SHEET NO.
55		McLEAN	87	44
STA. 39+800		TO STA. 40+486		
FED. ROAD DIST. NO.		ILLINOIS	FED. AID PROJECT	

• (57-4)RS-3 & I

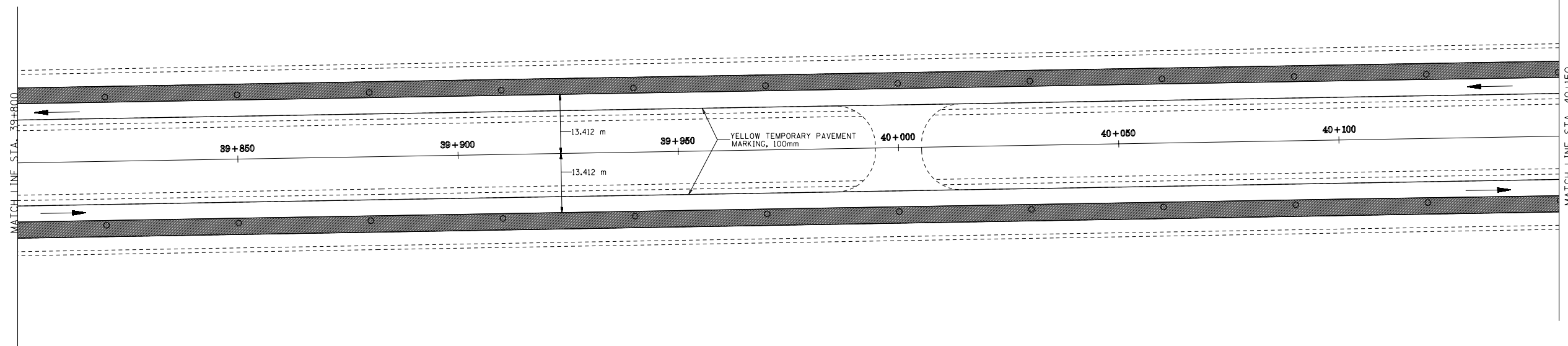

NOTE: CLOSURE OF THE SOUTHBOUND LANE SHALL BE IN ACCORDANCE WITH HIGHWAY STANDARD 701401. THE TAPER FOR THE LANE CLOSURE SHALL BEGIN AT STA. 43+000. HIGHWAY STANDARD 701411 SHALL BE USED AT THE ENTRANCE FROM BUSINESS 55 TO I55. THE MEDIAN LANE DEVELOPED AND DROPPED THROUGH BUSINESS 55 INTERCHANGE SHALL BE CLOSED WITH DRUMS WITH STEADY BURNING LIGHTS AT 30 m CENTERS.

LEGEND

- DRUM WITH STEADY BURNING MONODIRECTIONAL LIGHT AT 30 m OC. (UNLESS NOTED OTHERWISE)
- WORK ZONE
- TRAFFIC

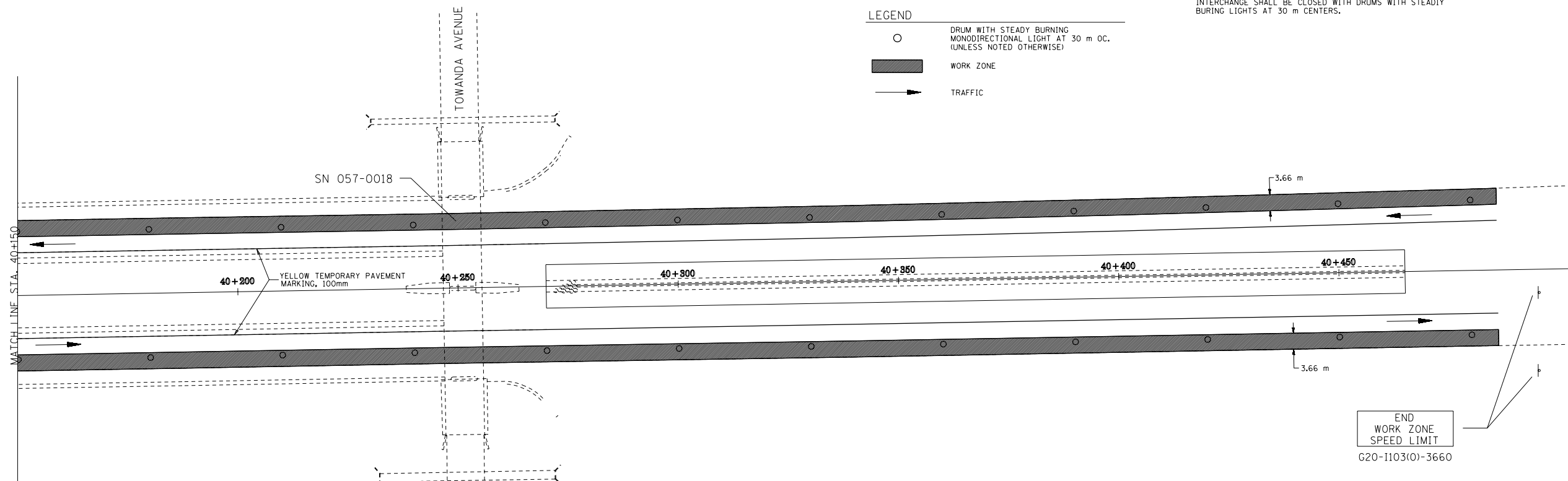

STAGE CONSTRUCTION DETAILS - STAGE 2
 F.A.I. 55
 SECTION (57-4)RS-3 & I
 McLEAN COUNTY

F.A.I. RTE.	SECTION	COUNTY	TOTAL SHEETS	SHEET NO.
55		McLEAN	87	45
STA. 36+305		TO STA. 37+00		
FED. ROAD DIST. NO.		ILLINOIS FED. AID PROJECT		

• (57-4)RS-3 & 1

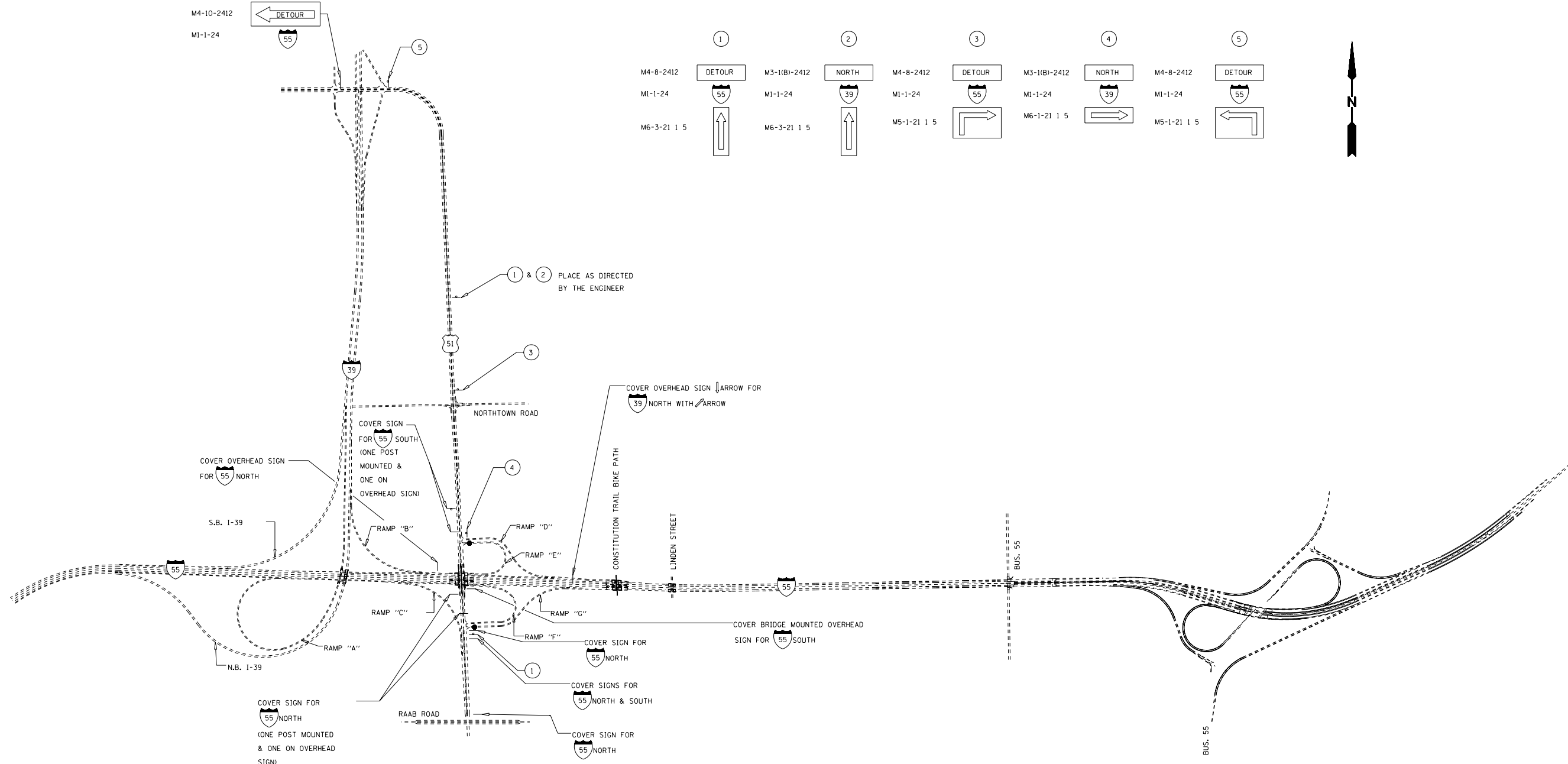

NOTE: RAMPS B, E, F, AND G WILL BE CLOSED DURING STAGE 2 CONSTRUCTION.

TYPE III BARRICADES AT STATION 37+850 LT. AS SHOWN ON SHEET 41 ARE INCLUDED IN THE PAY ITEM "TRAFFIC CONTROL AND PROTECTION FOR TEMPORARY DETOUR". FOR ADDITIONAL INFORMATION, SEE THE SPECIAL PROVISION "TRAFFIC CONTROL AND PROTECTION FOR TEMPORARY DETOUR".

● PLACE TYPE III BARRICADES WITH R11-2-4830 "ROAD CLOSED" SIGN TO CLOSE RAMPS "E" AND "G". PLACE DRUMS WITH STEADY BURNING LIGHTS AT 8m CTS TO CLOSE SB LEFT TURN LANE TO RAMPS "E" AND "G" AND NB RIGHT TURN TO RAMP "E". SET TRAFFIC SIGNALS AT RAMP "F" & "G" INTERSECTION WITH BUS 51 TO FLASHING YELLOW

DETOUR PLAN
 STAGE II CONSTRUCTION
 F.A.I. 55
 SECTION (57-4)RS-3 & 1
 McLEAN COUNTY

F.A.I. RTE.	SECTION	COUNTY	TOTAL SHEETS	SHEET NO.
55		McLEAN	87	46
STA. 36+305		TO STA. 37+00		
FED. ROAD DIST. NO.		ILLINOIS FED. AID PROJECT		

• (57-4)RS-3 & I

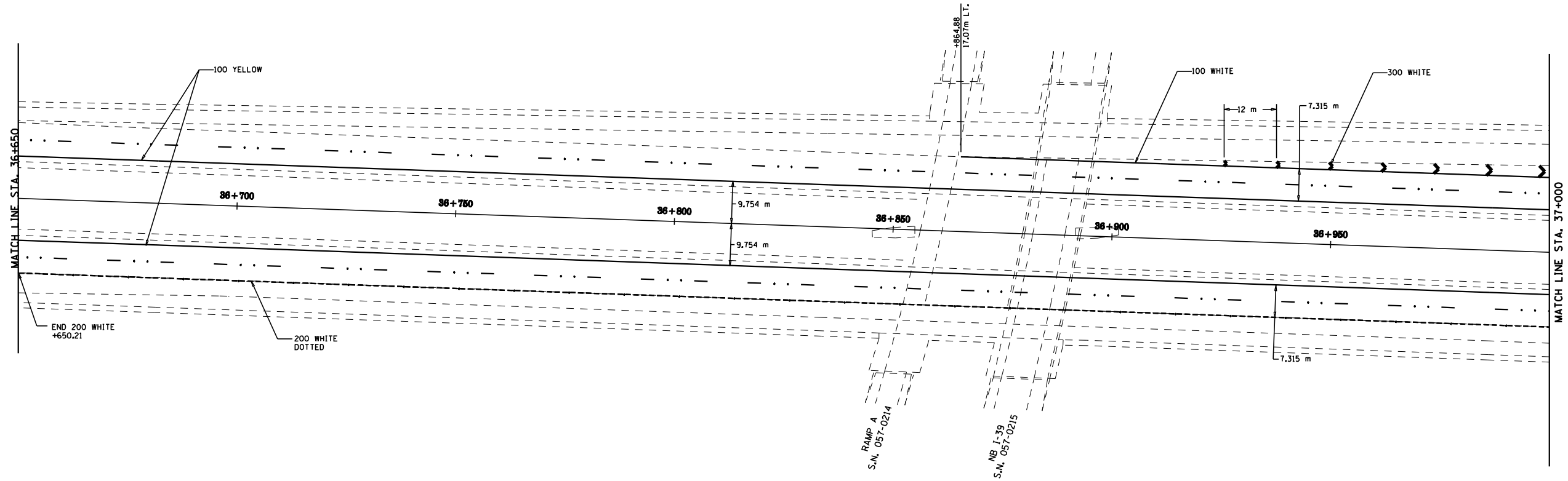
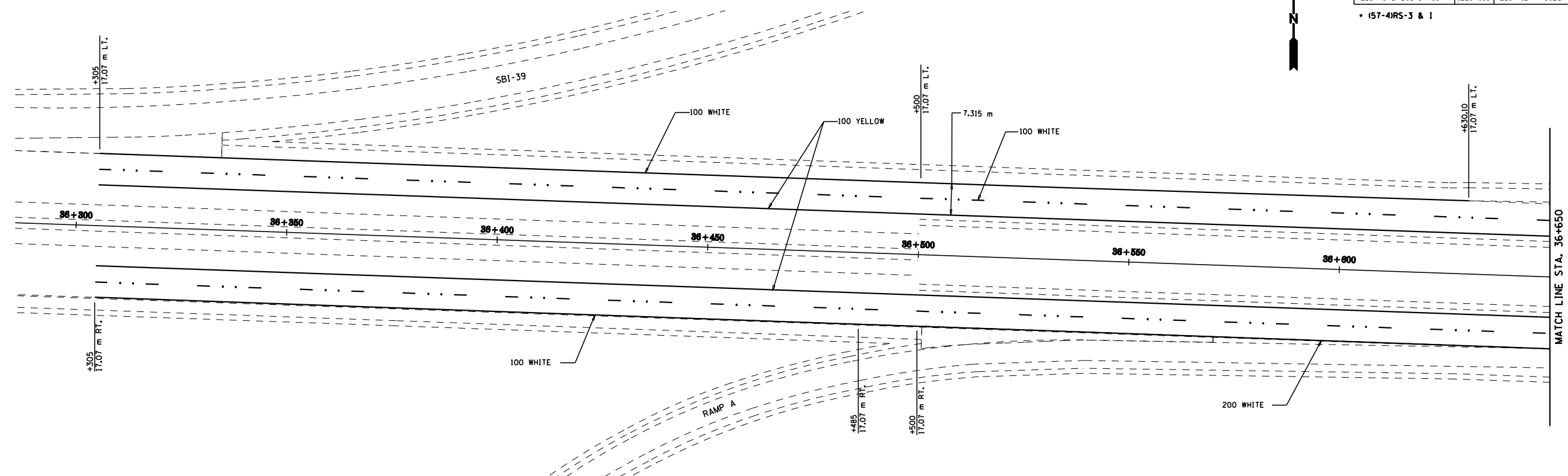
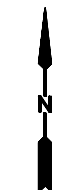

PAVEMENT MARKING DETAILS
 F.A.I. 55
 SECTION (57-4)RS-3 & I
 McLEAN COUNTY

F.A.I. RTE.	SECTION	COUNTY	TOTAL SHEETS	SHEET NO.
55		McLEAN	87	47
STA. 37+000		TO STA. 37+700		
FED. ROAD DIST. NO.		ILLINOIS FED. AID PROJECT		

(57-4)RS-3 & I

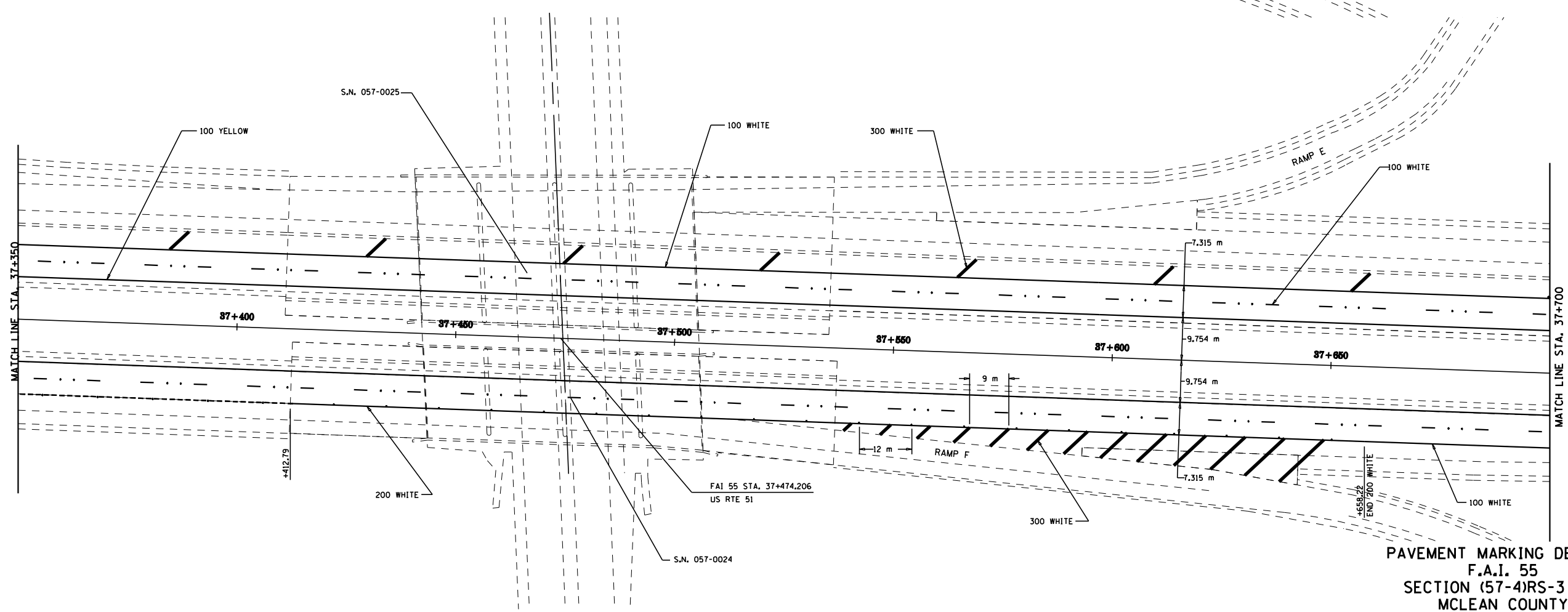
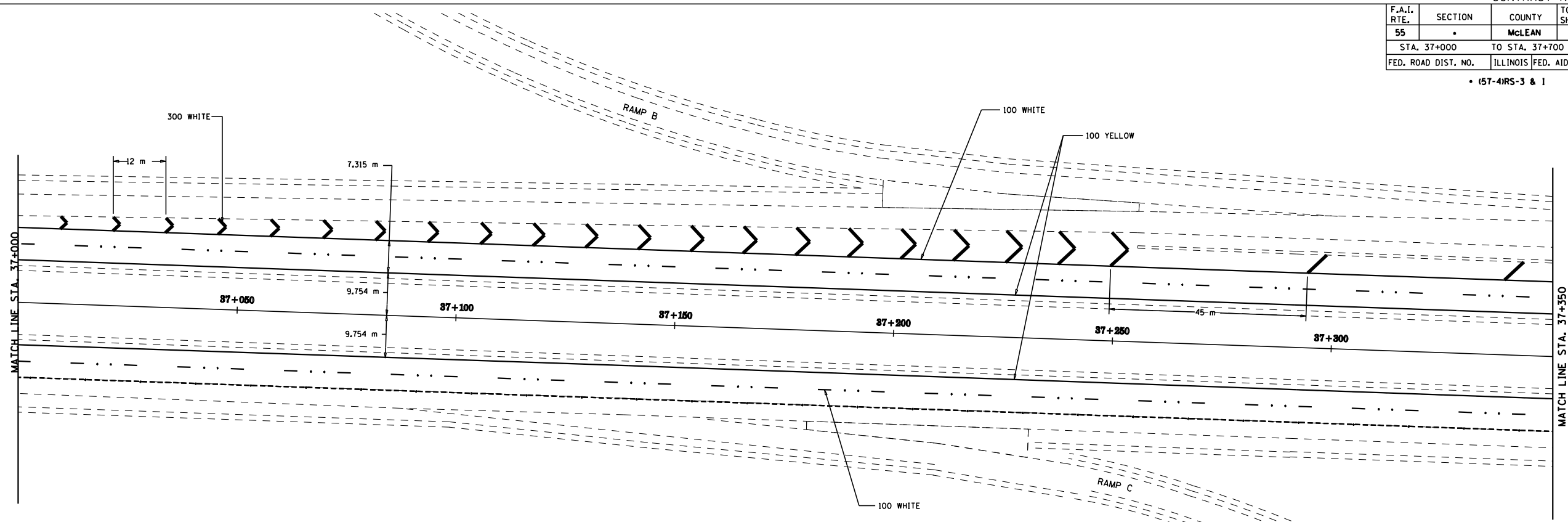
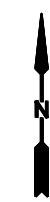

PAVEMENT MARKING DETAILS
 F.A.I. 55
 SECTION (57-4)RS-3 & I
 MCLEAN COUNTY

F.A.I. RTE.	SECTION	COUNTY	TOTAL SHEETS	SHEET NO.
55		McLEAN	87	48
STA. 37+700		TO STA. 38+400		
FED. ROAD DIST. NO.		ILLINOIS FED. AID PROJECT		

• (57-4)RS-3 & I

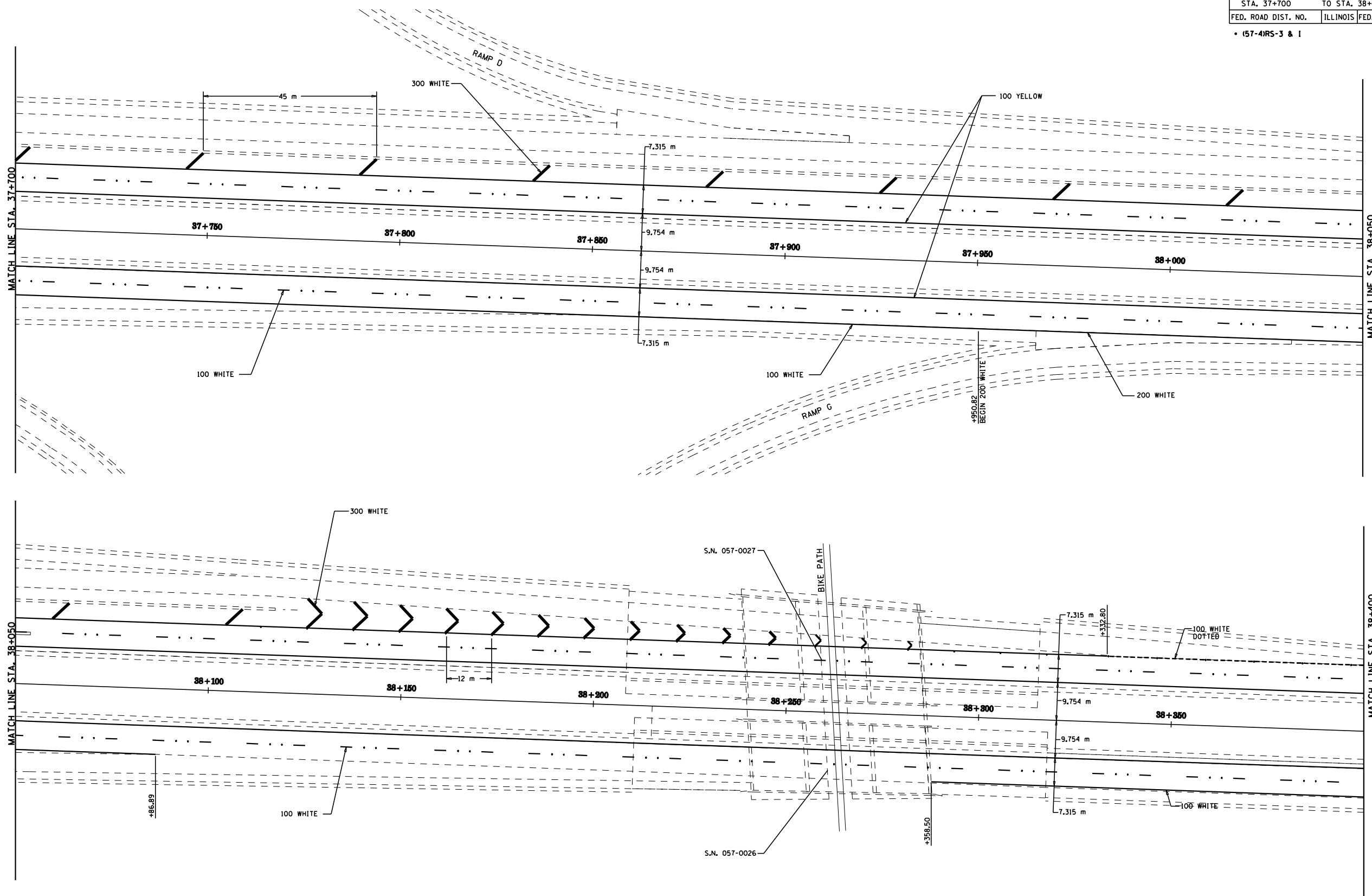

PAVEMENT MARKING DETAILS
 F.A.I. 55
 SECTION (57-4)RS-3 & I
 MCLEAN COUNTY

F.A.I. RTE.	SECTION	COUNTY	TOTAL SHEETS	SHEET NO.
55		McLEAN	87	49
STA. 38+400		TO STA. 39+100		
FED. ROAD DIST. NO.		ILLINOIS FED. AID PROJECT		

• (57-4)RS-3 & I

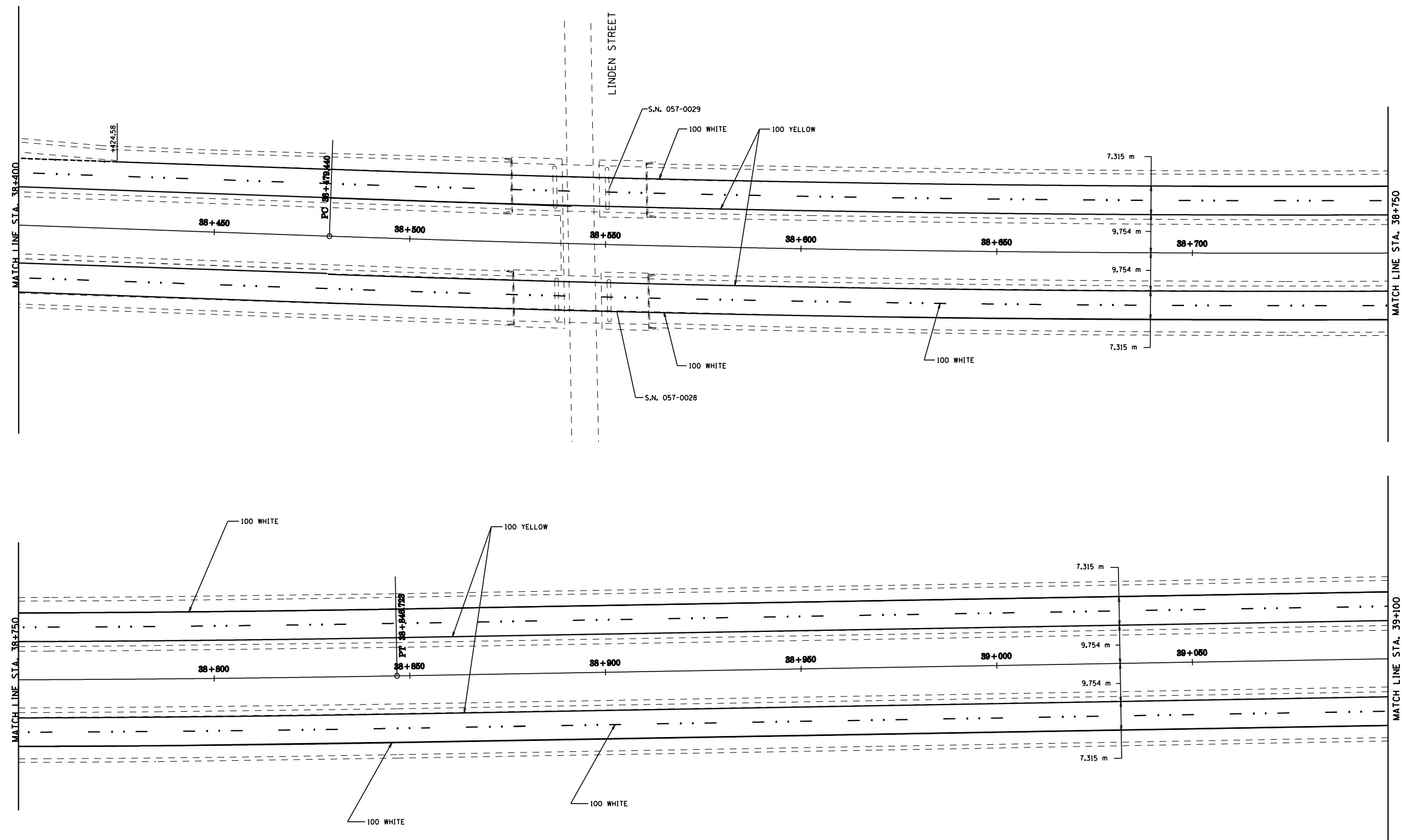

PAVEMENT MARKING DETAILS
 F.A.I. 55
 SECTION (57-4)RS-3 & I
 MCLEAN COUNTY

F.A.I. RTE.	SECTION	COUNTY	TOTAL SHEETS	SHEET NO.
55		McLEAN	87	50
STA. 39+100		TO STA. 39+800		
FED. ROAD DIST. NO.		ILLINOIS FED. AID PROJECT		

• (57-4)RS-3 & I

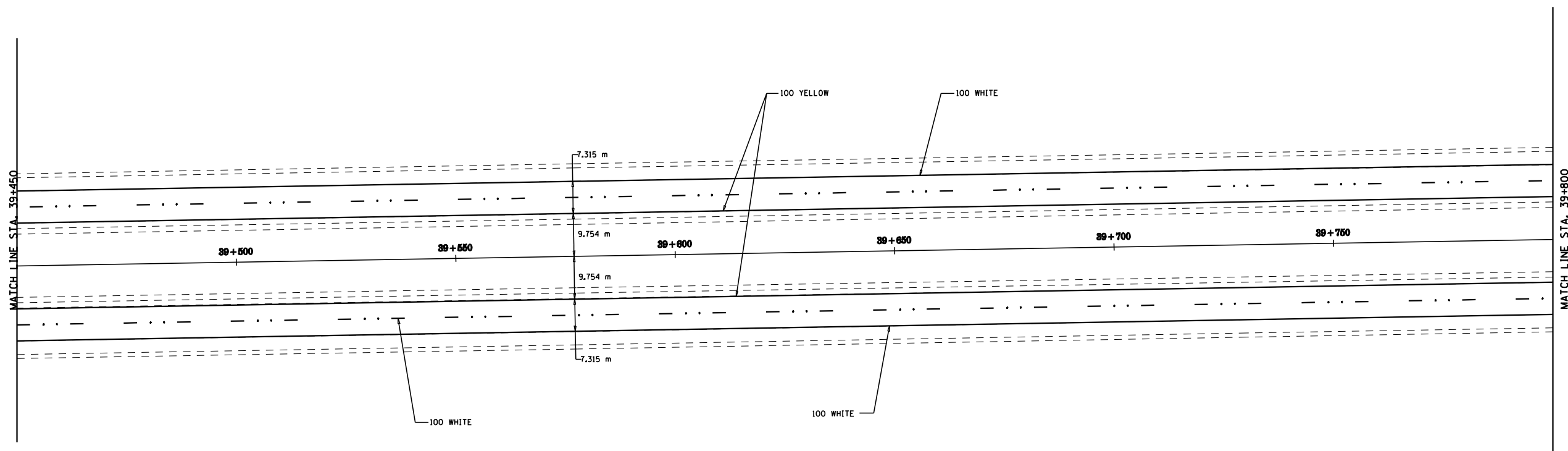
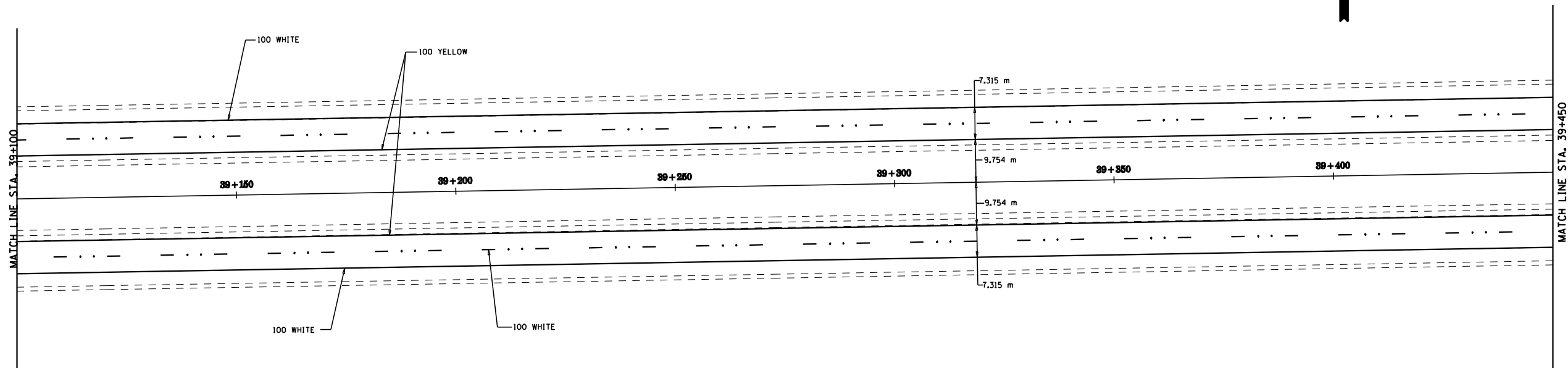

PAVEMENT MARKING DETAILS
 F.A.I. 55
 SECTION (57-4)RS-3 & I
 McLEAN COUNTY

F.A.I. RTE.	SECTION	COUNTY	TOTAL SHEETS	SHEET NO.
55		McLEAN	87	51
STA. 39+800		TO STA. 40+486		
FED. ROAD DIST. NO.		ILLINOIS FED. AID PROJECT		

• (57-4)RS-3 & I

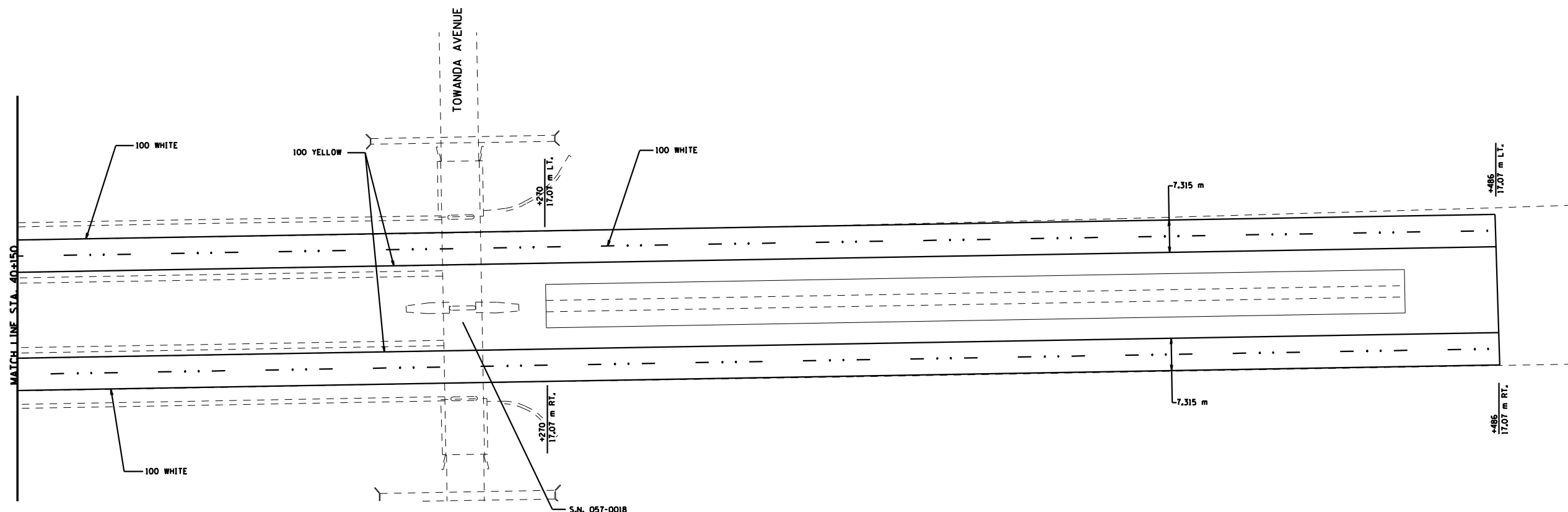
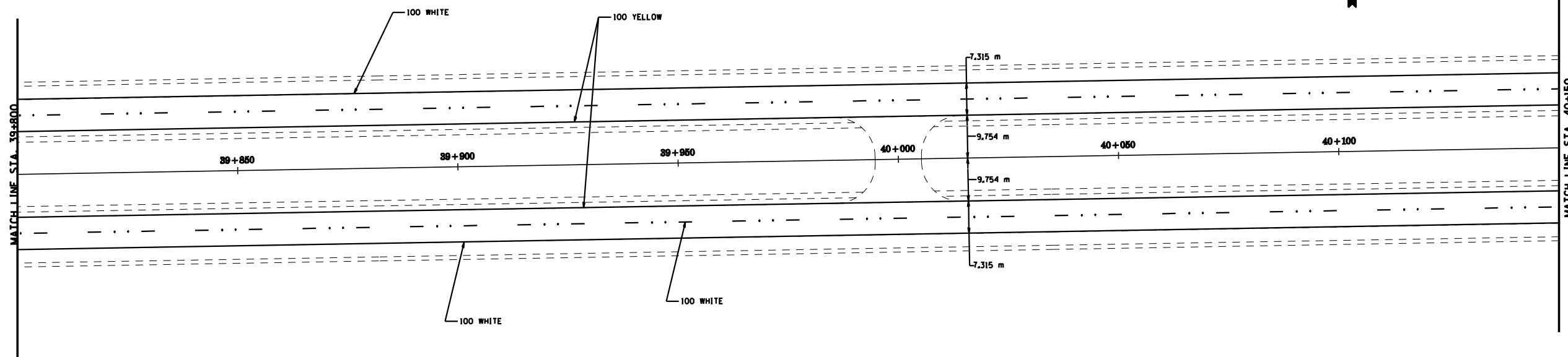

PAVEMENT MARKING DETAILS
 F.A.I. 55
 SECTION (57-4)RS-3 & I
 MCLEAN COUNTY

F.A. RTE.	SECTION	COUNTY	TOTAL SHEETS	SHEET NO.
55	•	McLEAN	87	52
STA. _____		TO STA. _____		
FED. ROAD DIST. NO. _____		ILLINOIS FED. AID PROJECT		

• (57-4)RS-3 & 1

BUTT JOINT

SHOULDERS PLUS 3.35m OF PASSING LANE

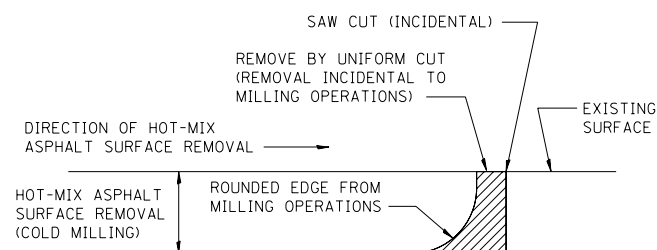
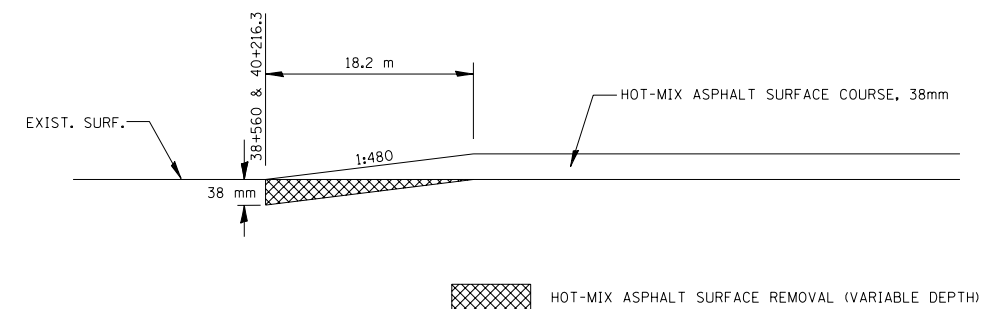

NOTE: WHEN MILLING OPERATIONS PRODUCE A ROUNDED EDGE, THEN A SAW CUT SHALL BE USED TO MANUFACTURE A PERPENDICULAR EDGE AS SHOWN IN THE DETAIL. THE ENGINEER SHALL BE THE SOLE JUDGE CONCERNING THE USE OF THIS DETAIL

HOT-MIX ASPHALT DETAIL AT BUTT JOINTS

406-8

BUTT JOINT

DRIVING LANE PLUS 0.305m OF PASSING LANE

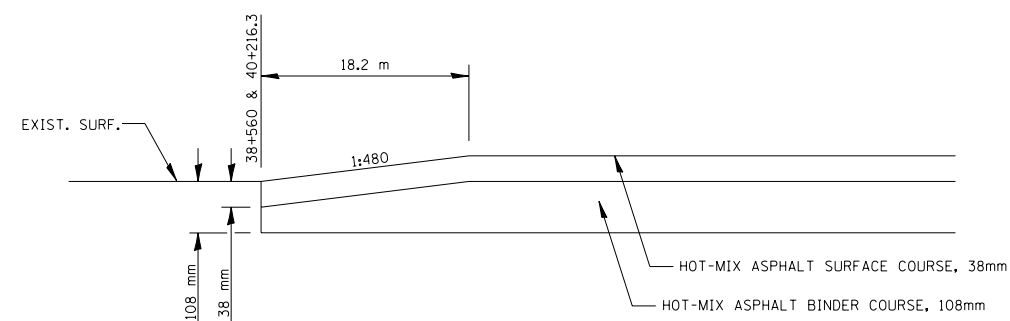

F.A. RTE.	SECTION	COUNTY	TOTAL SHEETS	SHEET NO.
55	•	McLEAN	87	53
STA.		TO STA.		
FED. ROAD DIST. NO.		ILLINOIS FED. AID PROJECT		

• (57-4)RS-3 & 1

GENERAL NOTES

1. THE 1:10 SLOPE CONTROLS NOSE OF ATTENUATOR BASE ELEVATION.
2. ATTENUATOR BASE GRADE PARALLELS EDGE OF PAVEMENT GRADE.
3. SLOPE ADJACENT TO ATTENUATOR BASE SHALL BE 1:10 OR FLATTER.

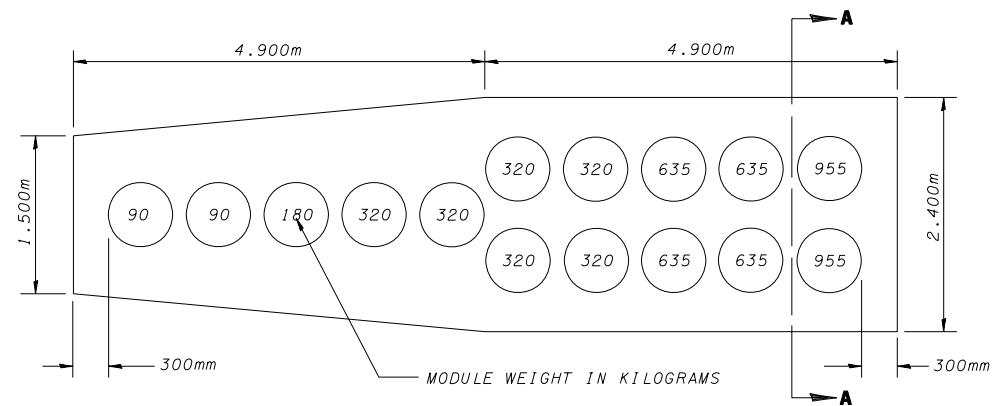
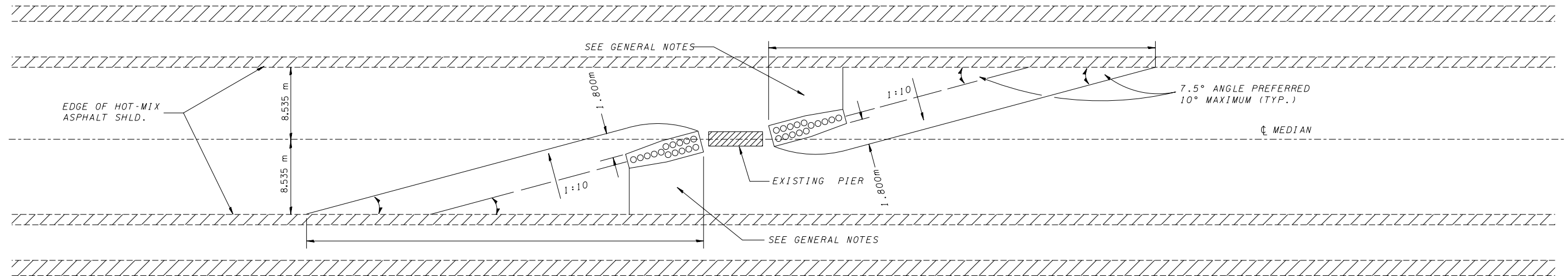

INERTIAL BARRIER MODULE ARRAY AND ATTENUATOR BASE PLAN

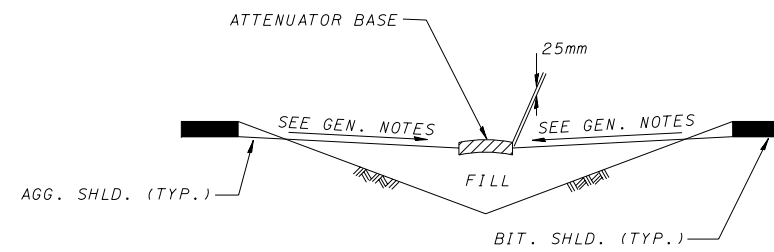

SECTION A - A

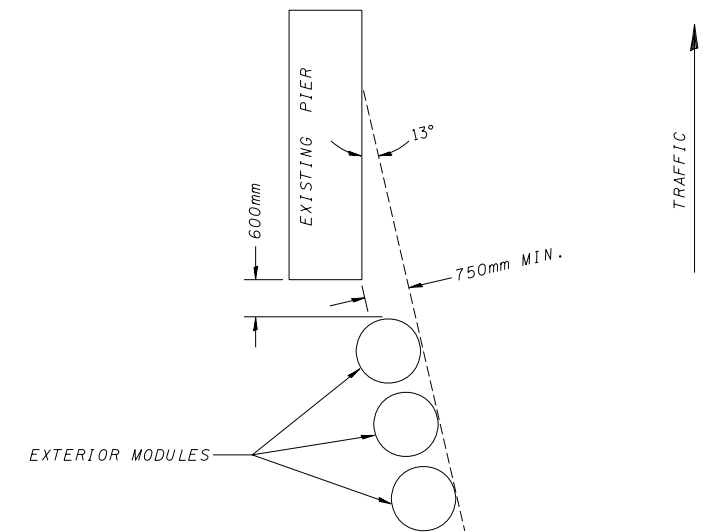

EXTERIOR MODULE LAYOUT

OCT. 1996
 IDETAILS1 400499.DGN
 406-7, 406-8

F.A. RTE.	SECTION	COUNTY	TOTAL SHEETS	SHEET NO.
55	•	McLEAN	87	54
STA.		TO STA.		
FED. ROAD DIST. NO.		ILLINOIS FED. AID PROJECT		

• (57-4RS-3 & 1)

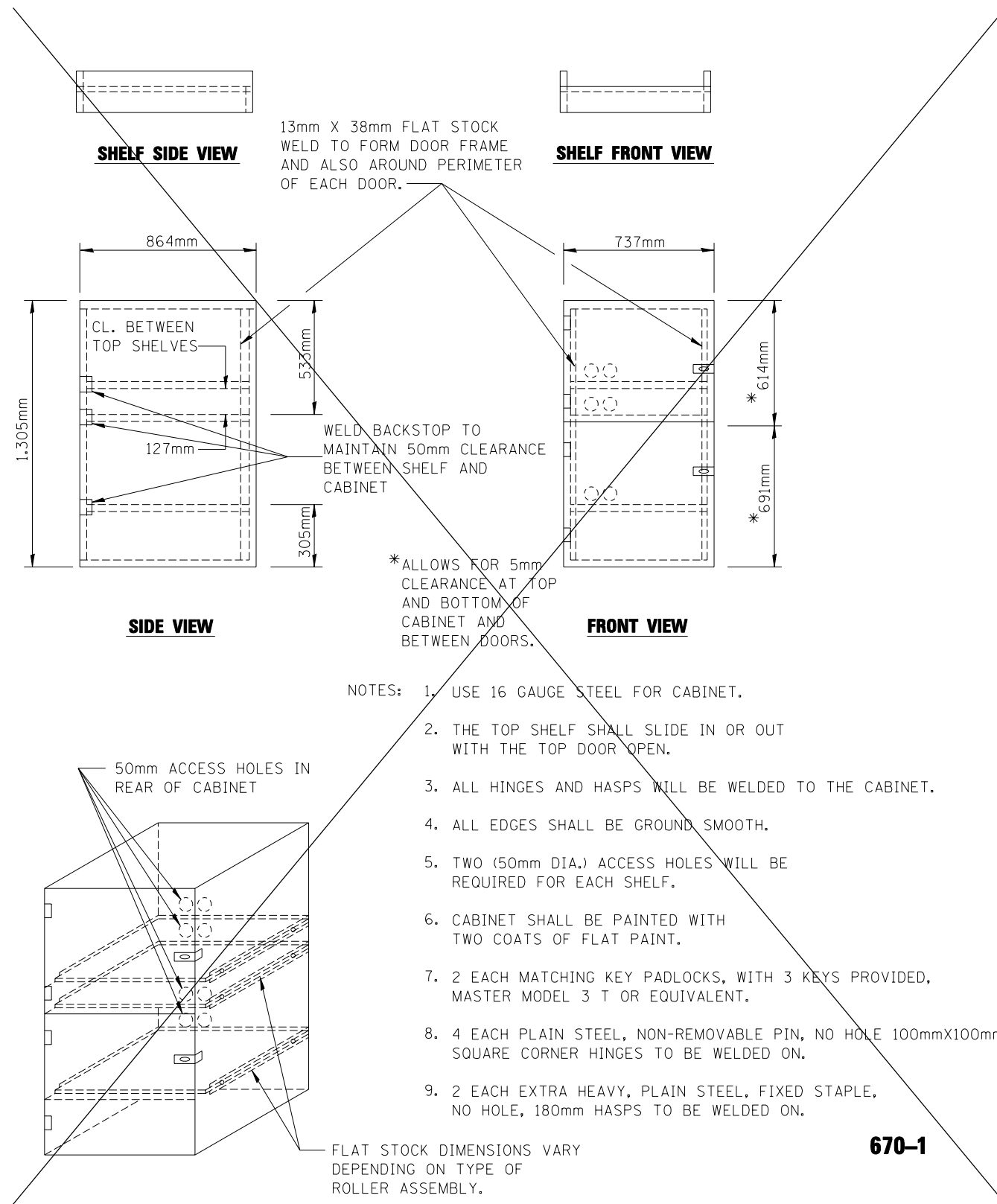

- NOTES:
1. USE 16 GAUGE STEEL FOR CABINET.
 2. THE TOP SHELF SHALL SLIDE IN OR OUT WITH THE TOP DOOR OPEN.
 3. ALL HINGES AND HASPS WILL BE WELDED TO THE CABINET.
 4. ALL EDGES SHALL BE GROUND SMOOTH.
 5. TWO (50mm DIA.) ACCESS HOLES WILL BE REQUIRED FOR EACH SHELF.
 6. CABINET SHALL BE PAINTED WITH TWO COATS OF FLAT PAINT.
 7. 2 EACH MATCHING KEY PADLOCKS, WITH 3 KEYS PROVIDED, MASTER MODEL 3 T OR EQUIVALENT.
 8. 4 EACH PLAIN STEEL, NON-REMOVABLE PIN, NO HOLE 100mmX100mm SQUARE CORNER HINGES TO BE WELDED ON.
 9. 2 EACH EXTRA HEAVY, PLAIN STEEL, FIXED STAPLE, NO HOLE, 180mm HASPS TO BE WELDED ON.

670-1

LOCKABLE COMPUTER CABINET

DETAILS
F.A.I. 55
SECTION (57-4)RS-3 & 1
MCLEAN COUNTY

OCT. 1996
DETAILS
670-1
600699.DGN

F.A. RTE.	SECTION	COUNTY	TOTAL SHEETS	SHEET NO.
55		McLEAN	87	55
STA.		TO STA.		
FED. ROAD DIST. NO.		ILLINOIS FED. AID PROJECT		

• (57-4)RS-3 & 1

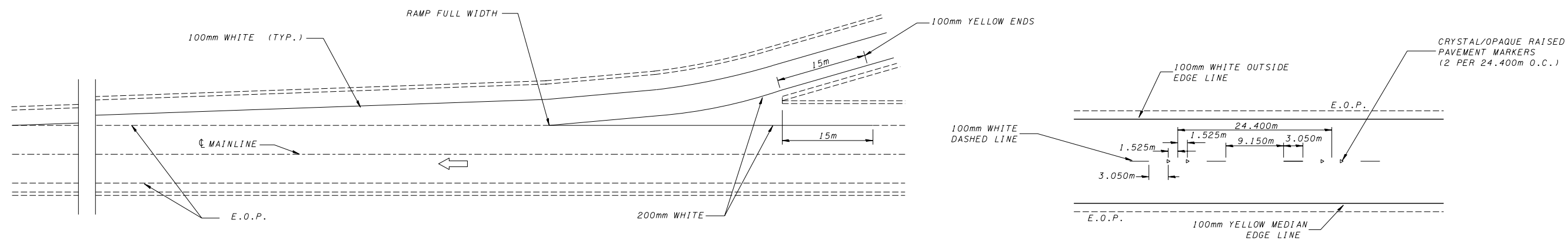

TYPICAL PAVEMENT MARKING FOR ENTRANCE RAMP TERMINALS

TYPICAL PAVEMENT MARKINGS

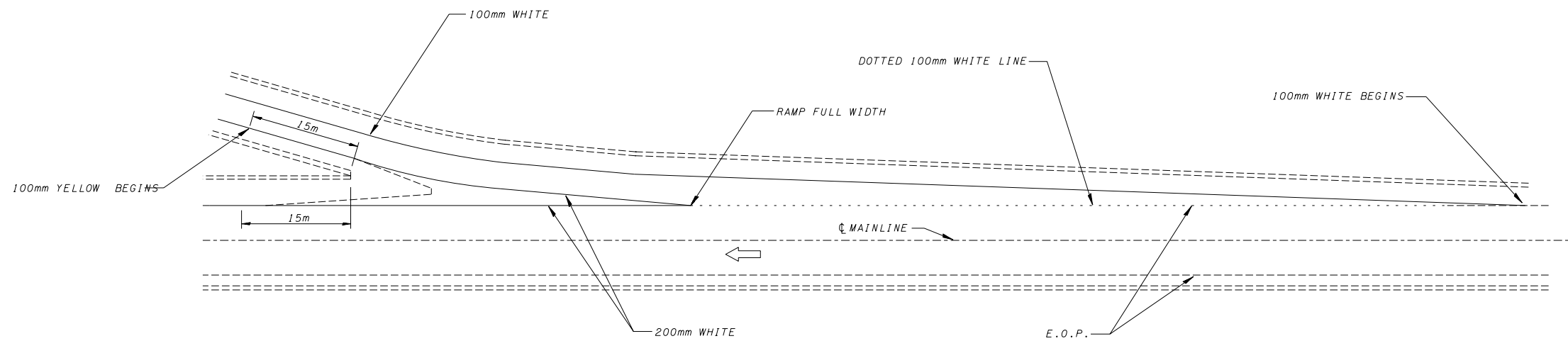

TYPICAL PAVEMENT MARKINGS FOR EXIT RAMP TERMINALS

780-12

JAN. 1997
[DETAILS] 700799.DGN
780-12

DETAILS
F.A.I. 55
SECTION (57-4)RS-3 & 1
MCLEAN COUNTY

Bench Mark: Disk on Centerline F.A.I. I-55 at Sta. 37+139.078 Elev.=261.851

Bench Mark: Disk at Sta. 36+971.437 Along Centerline F.A.I. I-55 Elev.=259.492

ROUTE NO.	SECTION	COUNTY	SHEETS	"A"	SHEET NO. 1
FAI 55	"	McLEAN	87	56	3 SHEETS
FED. ROAD DIST. NO. 7		ILLINOIS	FED. AID PROJECT		

• (57-4)RS-3 & 1

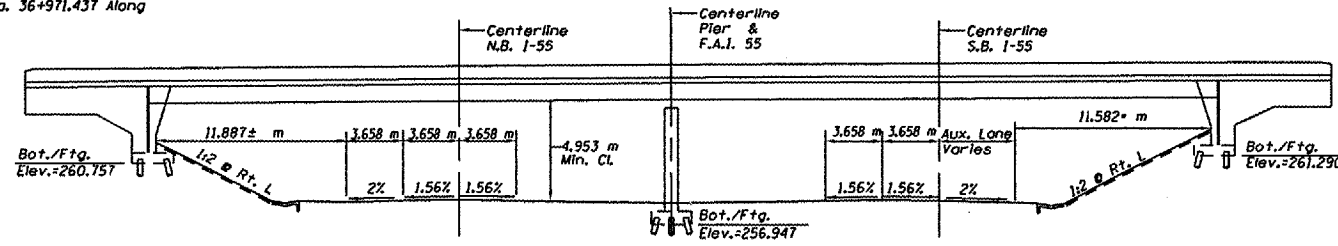

ELEVATION
SN-057-0214

MB 139
 P.I. STA. = 97+50.58 "English"
 Δ = 20° 00' 00"
 R = 878.030 m
 D = 1° 59' 20"
 T = 154.820 m
 L = 306.489 m
 E = 13.545 m
 S.E. = 5.25%
 S.E. TRANS. = FROM 91+15.14 "English" TO 93+70.14 "English"
 FROM 101+63.19 "English" TO 104+18.19 "English"
 P.C. STATION = 92+42.64 "English"
 P.T. STATION = 102+48.18 "English"

RAMP A
 P.I. STA. = 30+60.63 "English"
 Δ = 30° 49' 45"
 R = 698.551 m
 D = 2° 30' 00"
 T = 192.603 m
 L = 375.871 m
 E = 26.066 m
 S.E. = 5.75%
 S.E. TRANS. = FROM 22+58.73 "English" TO 25+13.73 "English"
 FROM 24+28.73 "English" TO 36+61.89 "English"

Proposed Work

1. Structural Repair of Concrete at all four abutments.
2. Structural Repair of Concrete at South abutment sloped wall for SN 057-0214 (SBI).
3. Place Stone Dumped Riprap along abutment walls and sloped walls at all four abutments.

TOTAL BILL OF MATERIALS		
Item	Unit	Qty.
Stone Dumped Riprap, Class A4	sq m	23
Structural Repair of Concrete (Depth equal to or less than 125 mm)	sq m	10.5

General Notes

Plan dimensions and details relative to existing plans are subject to routine variations. The Contractor shall field verify existing dimensions and details affecting new construction and make necessary approved adjustments prior to construction or ordering of materials. Such variations shall not be cause for additional compensation for a change in scope of the work, however, the Contractor will be paid for the quantity actually furnished based upon the unit price bid for the work.

All dimensions are in millimeters (mm) except as noted.

Stationing for structures has been shown in English units for I-39 and Ramp A stations because metric stationing is not available. Where shown elevations are in metric units.

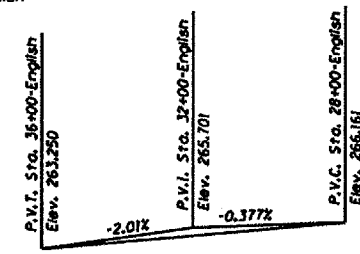
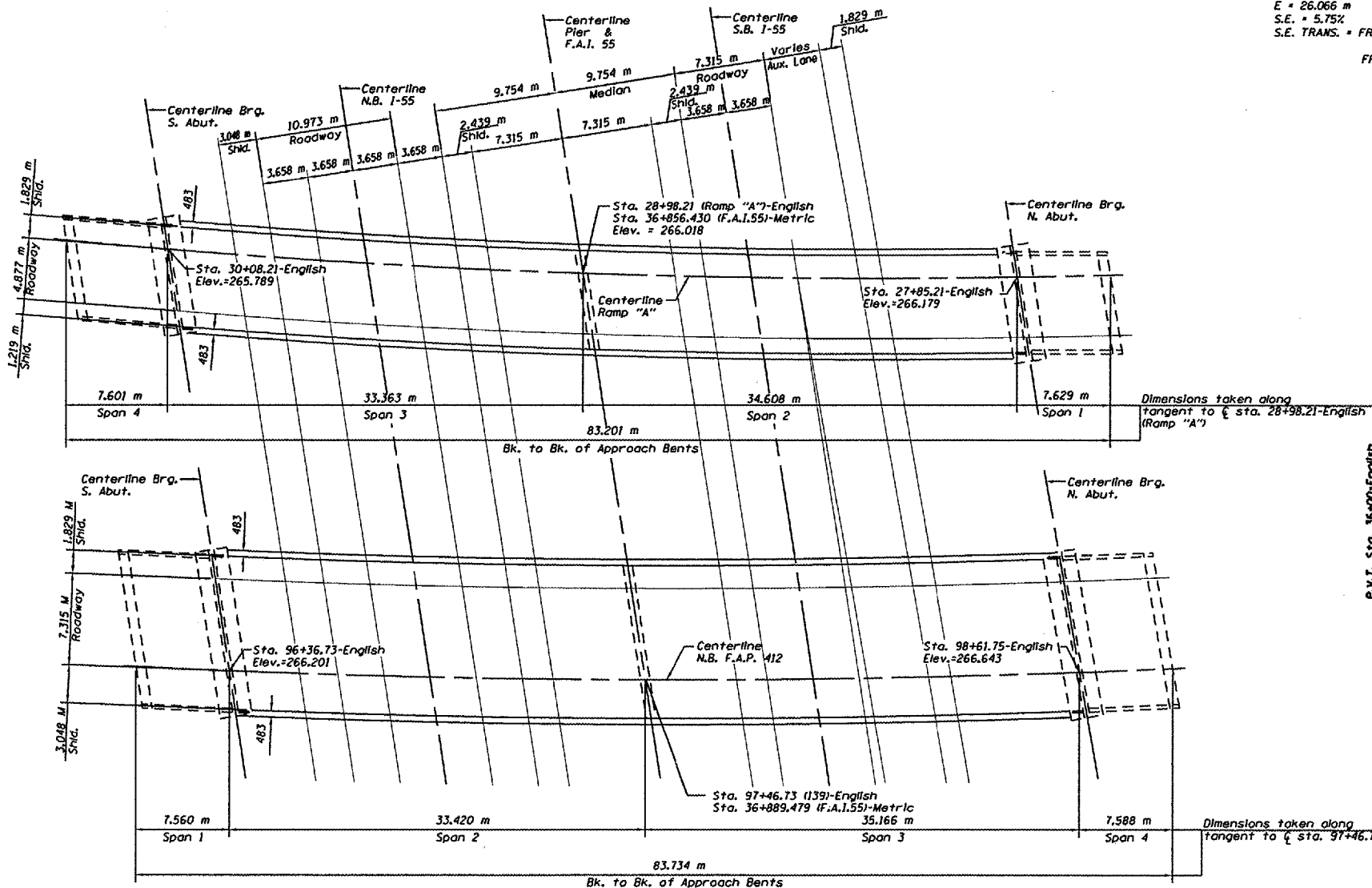

PROFILE GRADE RAMP "A"

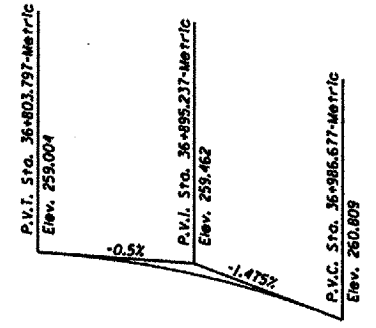

PROFILE GRADE F.A.I.-55

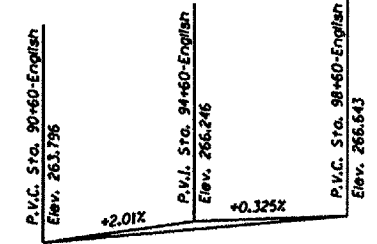

PROFILE GRADE NB 139

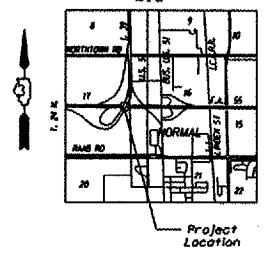
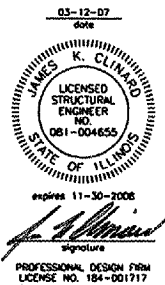

LOCATION SKETCH

DESIGNED	--
CHECKED	--
DRAWN	NO
CHECKED	JKC



PLAN

CHAMLIN ASSOCIATES
 PERU ILLINOIS MORRIS

GENERAL PLAN AND ELEVATION
 I-39 OVER F.A.I. ROUTE 55
 SECTION (57-4)RS-3 & 1
 McLEAN COUNTY
 SN 057-0214 (RAMP A)
 SN 057-0215 (NB I-39)

ROUTE NO.	SECTION	COUNTY	POST MILE	POST MILE	SHEET NO.
FAJ 55		McLEAN	87	57	3 SHEETS
FED. ROAD DIST. NO. 7		ILL. HIGH.	FED. AID PROJECT		

• (57-4)RS-3 & 1

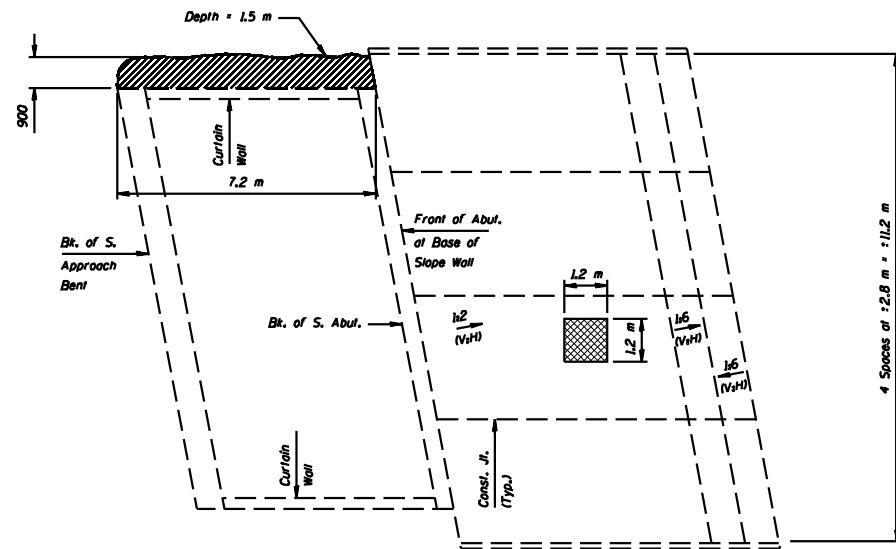

S. ABUT. AND SLOPE WALL PLAN

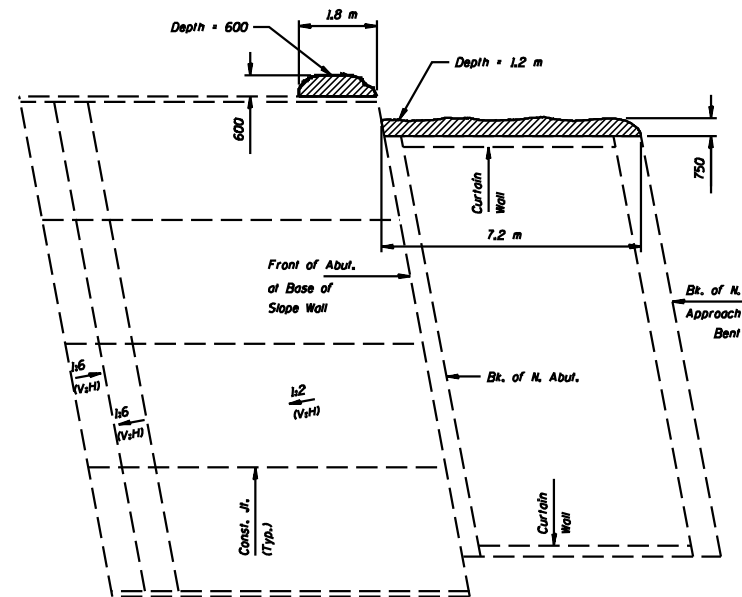

N. ABUT. AND SLOPE WALL PLAN

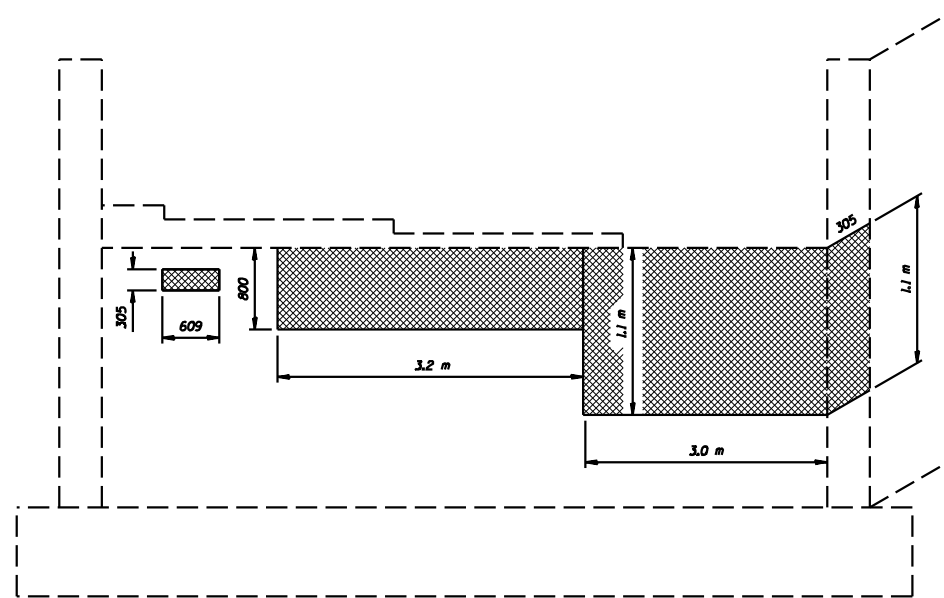

SOUTH ABUTMENT

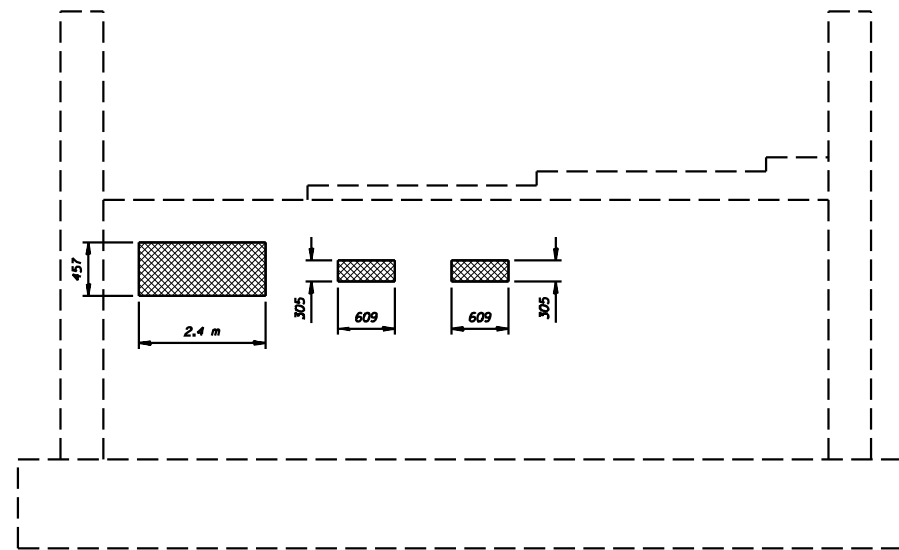

NORTH ABUTMENT

DESIGNED	--
CHECKED	--
DRAWN	NO
CHECKED	JKC

- Structural Repair of Concrete (Depth Equal To or Less Than 125 mm)
- Denotes eroded areas requiring backfill. Use Stone Dumped Riprap, Class A4 as backfill material.

TOTAL BILL OF MATERIAL

ITEM	UNIT	QTY.
Stone Dumped Riprap, Class A4	m ²	13
Structural Repair of Concrete (Depth Equal To or Less Than 125 mm)	m ²	9.3

All dimensions are in millimeters (mm) except as noted.

**REPAIR PLAN-SN 057-0214
I-39 OVER F.A.I. ROUTE 55
SECTION (57-4)RS-3 & 1
McLEAN COUNTY
SN 057-0214 (RAMP A)
SN 057-0215 (NB I-39)**

ROUTE NO.	SECTION	COUNTY	DATE	SHEET NO.
FAI 55	*	MCLEAN	07 58	3
FED. ROAD DIST. NO. 7		ILL. HIGH.	FED. AID PROJECT	

* (57-4)RS-3 & 1

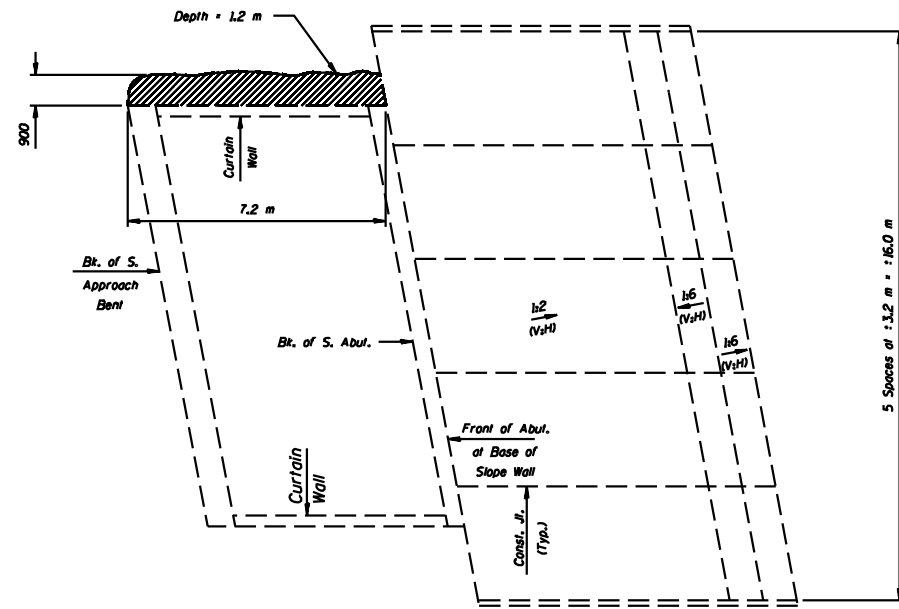

S. ABUT. AND SLOPE WALL PLAN

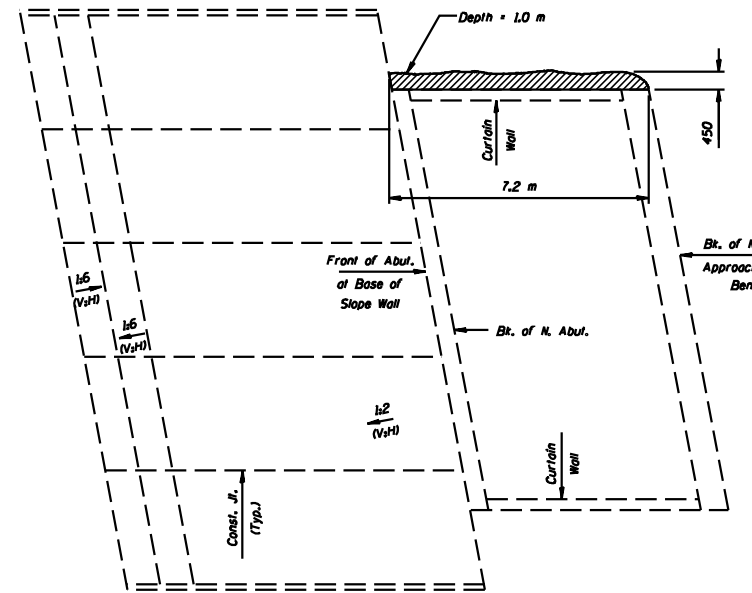

N. ABUT. AND SLOPE WALL PLAN

TOTAL BILL OF MATERIAL

ITEM	UNIT	QTY.
Stone Dumped Riprap, Class A4	m ²	10
Structural Repair of Concrete (Depth Equal To or Less Than 125 mm)	m ²	1.2

All dimensions are in millimeters (mm) except as noted.

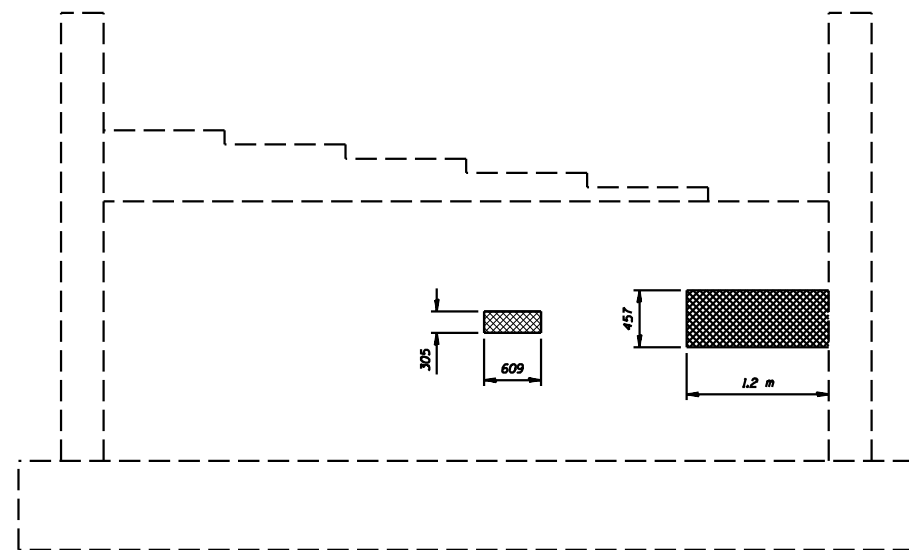

SOUTH ABUTMENT

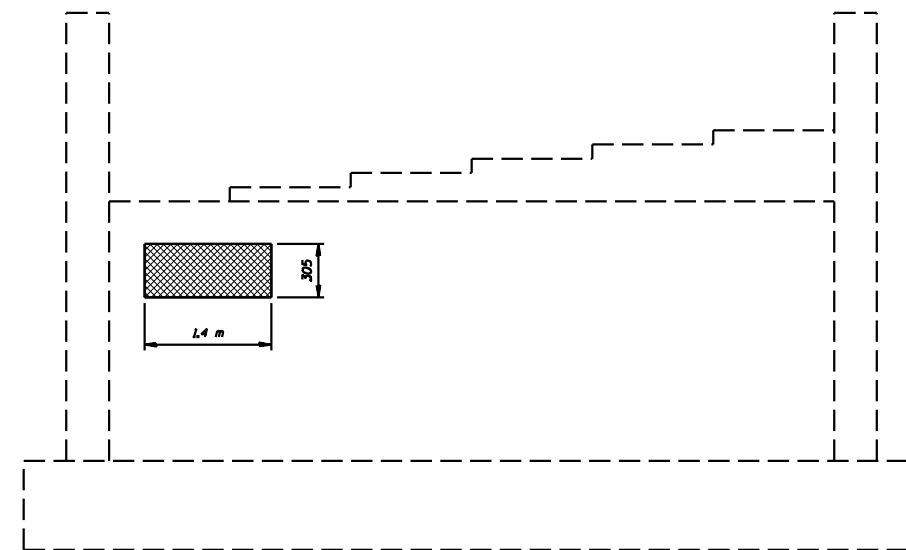

NORTH ABUTMENT

DESIGNED	--
CHECKED	--
DRAWN	NO
CHECKED	JKC

- Structural Repair of Concrete (Depth Equal To or Less Than 125 mm)
- Denotes eroded areas requiring backfill. Use Stone Dumped Riprap, Class A4 as backfill material.

**REPAIR PLAN-SN 057-0215
I-39 OVER F.A.I. ROUTE 55
SECTION (57-4)RS-3 & 1
MCLEAN COUNTY
SN 057-0214 (RAMP A)
SN 057-0215 (NB I-39)**

Benchmark: Disk on E of F.A.I. 55 at Sta. 37+535.318 Elev. 265.765

ROUTE NO.	SECTION	COUNTY	SHEET NO.	TOTAL SHEETS	SHEET NO. 1
FAI 55	4	McLEAN	87	59	10A SHEETS
FED. ROAD DIST. NO. 7		ILLINOIS	FED. ROAD PROJECT		

- Proposed Work
- Expansion joint removal and replacement.
 - Partial deck removal and replacement.
 - Add stud shear connectors at abutment ends of beams.
 - Structural Repair of Concrete at Piers

Existing Structures

Structure Number 057-0024 and 057-0025 are dual structures carrying F.A.I. Route 55 over Bus. U.S. 51. Section (57-4) RS-3 & I, McLean County at Station 38+474.206. Structures were built in 1962, widening and deck replacement occurred in 1990. The superstructures consist of 4 span, steel stringer, reinforced concrete slab deck with bk. to bk. abutment length of 63.576 m. The substructures consist of concrete pile bent abutments and multi-column piers.

See proposed work on this sheet for description of proposed improvements.

Traffic to be maintained by staged construction.

TOTAL BILL OF MATERIAL

Item	Unit	Super	Sub.	Total
CONCRETE REMOVAL	CU M	121.4	--	121.4
PREFORMED JOINT STRIP SEAL	METER	112.2	--	112.2
CONCRETE SUPERSTRUCTURE	CU M	121.4	--	121.4
PROTECTIVE COAT	SO M	537	--	537
REINFORCEMENT BARS, EPOXY COATED	KG	16950	--	16950
PROTECTIVE SHIELD	SO M	604	--	604
BRIDGE DECK GROOVING	SO M	432	--	432
STRUCTURAL REPAIR OF CONCRETE (DEPTH EQUAL TO OR LESS THAN 125 mm)	SO M	--	1.2	1.2
STRUCTURAL REPAIR OF CONCRETE (DEPTH GREATER THAN 125 mm)	SO M	--	0.2	0.2
BAR SPLICERS	EACH	198	--	198
STUD SHEAR CONNECTORS	EACH	2646	--	2646
SILICONE JOINT SEALER	METER	62.8	--	62.8

Quantities for Temporary Concrete Barrier and Relocate Temporary Concrete Barrier Included in Roadway Plans.

General Notes

- Reinforcement Bars designated (E) shall be Epoxy Coated.
- All new structural steel shall be shop pointed with the inorganic zinc rich primer per AASHTO M 300, Type I. Cost included with Furnishing and Erecting Structural Steel.
- The existing structural steel coating contains lead. The Contractor shall take appropriate precautions to deal with the presence of lead on this project.
- Field welding of construction accessories will not be permitted to beams or girders.
- Plan dimensions and details relative to existing plans are subject to routine variations. The Contractor shall field verify existing dimensions and details affecting new construction and make necessary approved adjustments prior to construction or ordering of materials. Such variations shall not be cause for additional compensation for a change in scope of the work, however, the Contractor will be paid for the quantity actually furnished based upon the unit price bid for the work.
- Any existing reinforcement bars which are intended to be incorporated into the new construction that are damaged during concrete removal operations shall be repaired or replaced using an approved bar splicer or anchorage system. Cost included with "Concrete Removal".
- All dimensions are in millimeters (mm) except as noted.
- All construction joints shall be bonded.
- Prior to pouring the new concrete deck, all loose rust, loose mill scale, and other loose potentially detrimental foreign material shall be removed from the surface of beams or girders in contact with concrete. The cost of this work will be included in the pay item covering removal of the existing concrete. All heavy rust and other tightly adhered potentially detrimental foreign matter shall also be removed from the surfaces of the beams of girders in contact with concrete. Tightly adhered paint may remain unless otherwise noted. This removal shall be accomplished by methods that will not damage the steel. The cost of this work will be paid for according to Article 109.04.
- Reinforcement Bars shall conform to the requirements of ASTM A706 Grade 60 (11, MOD.) See Special Provisions.

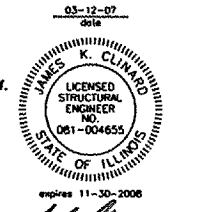

DESIGN STRESSES

(EXISTING CONSTRUCTION)
 Concrete: f'c = 24 Mpa
 Reinforcement: fs (1962) = 138 Mpa
 fs (1990) = 400 Mpa
 Structural Steel: fs (1962) = 124 Mpa
 fs (1990) = 248 Mpa

Design Loading: MS18 & Alternate
 Allow 1.2 kN/m for future wearing surface.
 Design Specifications: AASHTO (1983) plus 1984 thru 1988 Interims.

DESIGN STRESSES

(NEW CONSTRUCTION)
 Concrete: f'c = 24 Mpa
 Reinforcement: fy = 400 Mpa
 Structural Steel: fy = 248 Mpa
 Design Specifications: AASHTO 2002 and Interims

R. 2 E., 3rd P.M.

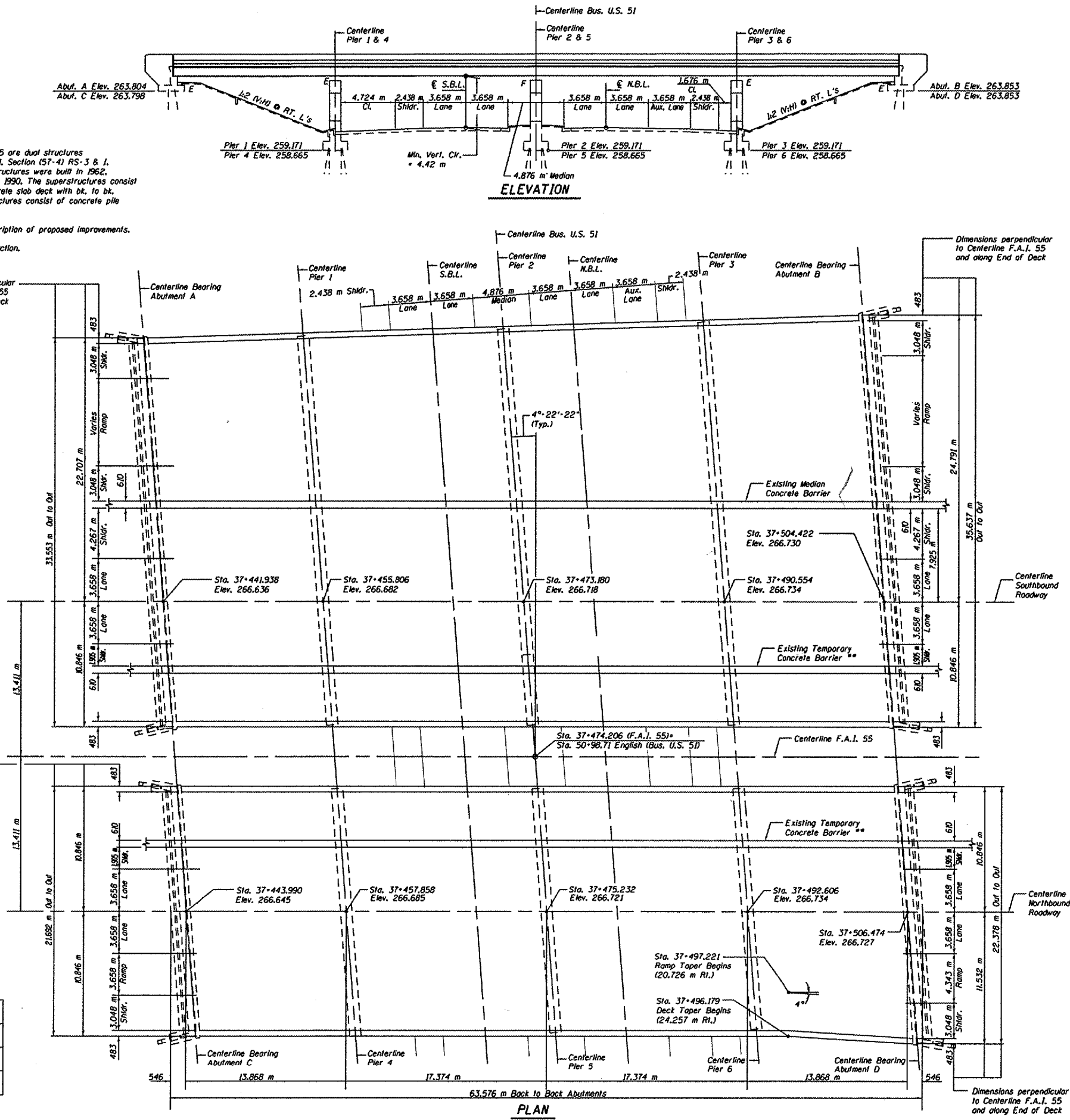
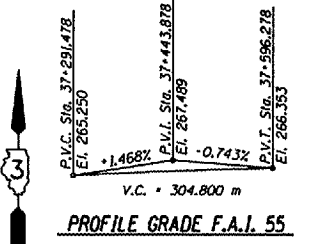
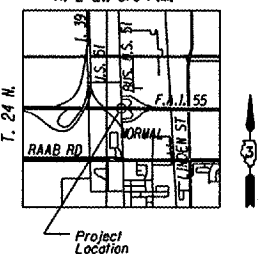

DESIGNED	GAE
CHECKED	JDA
DRAWN	NO
CHECKED	GAE

CHAMLIN & ASSOCIATES
 PERU ILLINOIS MORRIS

GENERAL PLAN AND ELEVATION
F.A.I. 55 OVER BUSINESS U.S. 51
SECTION (57-4)RS-3 & I
McLEAN COUNTY
 SN 057-0024 (NB)
 SN 057-0025 (SB)
STA. 37+474.206

ROUTE NO.	SECTION	COUNTY	STATE	SHEET NO.
FAI 55		McLEAN	87	60
FED. ROAD DIST. NO. 7		ILL. HIGH.	FED. AID PROJECT	

• (57-4)RS-3 & 1

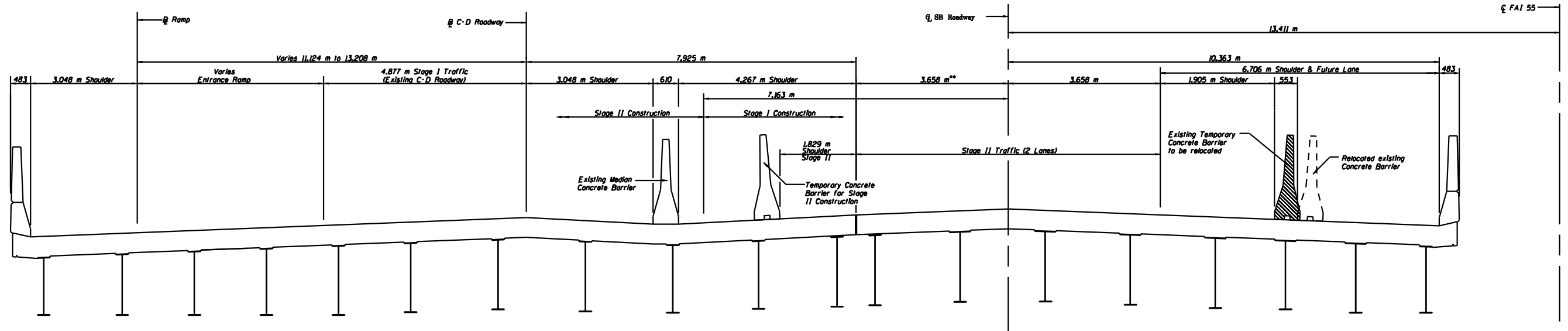

** This lane may experience temporary closure due to pavement patching and resurfacing work off the bridge deck.

CROSS SECTION (SN 057-0025)
(Looking East)

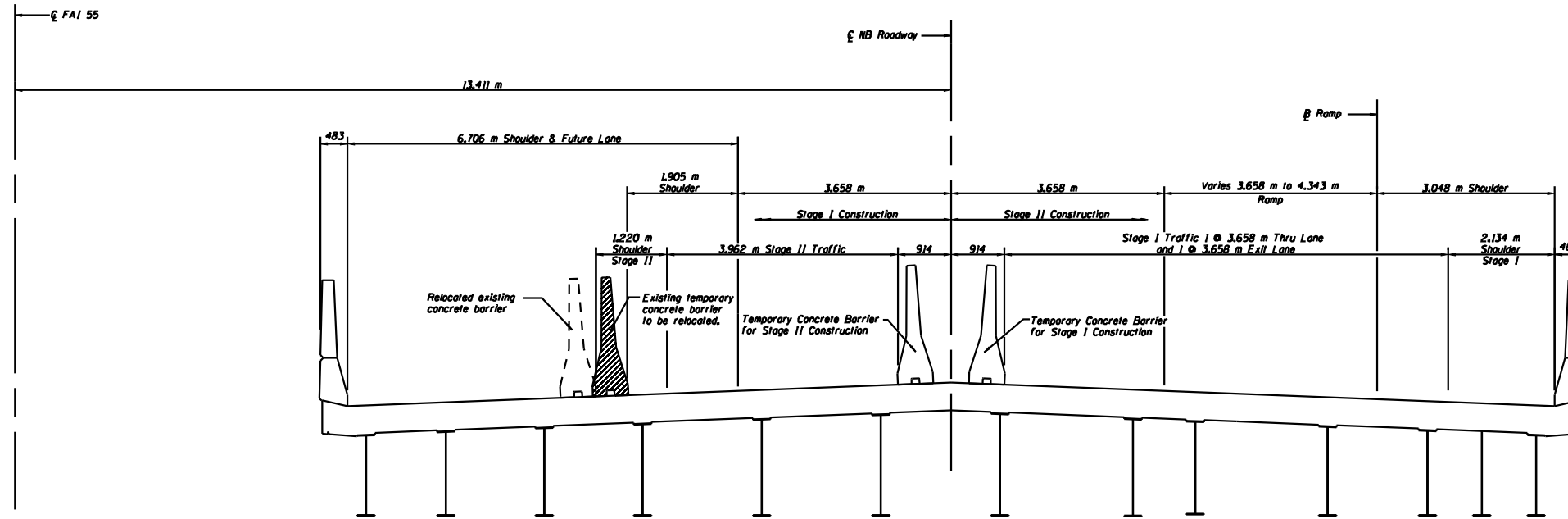

CROSS SECTION (SN 057-0024)
(Looking East)

DESIGNED	GAE
CHECKED	JDA
DRAWN	NO
CHECKED	GAE

STAGE CONSTRUCTION
F.A.I. 55 OVER BUSINESS U.S. 51
SECTION (57-4)RS-3 & 1
McLEAN COUNTY
SN 057-0024 (NB)
SN 057-0025 (SB)
STA. 37+474.206

ROUTE NO.	SECTION	COUNTY	DATE	SHEET NO.
FAI 55		McLEAN	07	61
10A SHEETS				
FED. ROAD DIST. NO. 7	ILL. PROJ. NO.	FED. AID PROJECT NO.		

• (57-4)RS-3 & 1

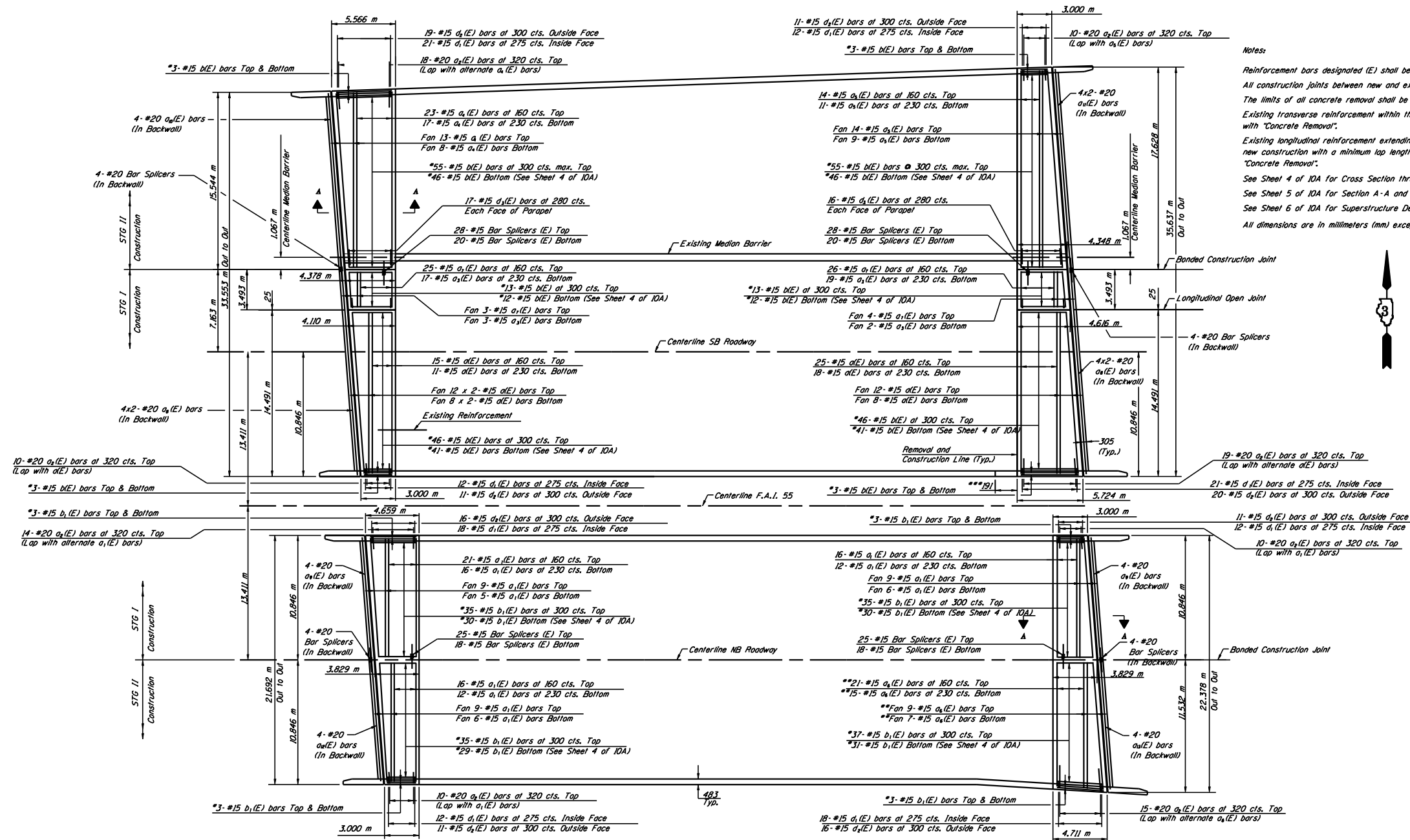

Notes:
 Reinforcement bars designated (E) shall be epoxy coated.
 All construction joints between new and existing construction shall be Bonded Construction Joints.
 The limits of all concrete removal shall be saw cut 20 mm into concrete.
 Existing transverse reinforcement within the removal area shall be cut off flush with the removal line. Cost included with "Concrete Removal".
 Existing longitudinal reinforcement extending into removed areas shall be cleaned, straightened and incorporated into the new construction with a minimum lap length of 610 mm except as noted. Cost included with "Concrete Removal".
 See Sheet 4 of 10A for Cross Section thru deck.
 See Sheet 5 of 10A for Section A-A and Silicone Joint Sealer Details.
 See Sheet 6 of 10A for Superstructure Details, Parapet Reinforcement, Bar Details and Bill of Material.
 All dimensions are in millimeters (mm) except as noted.



PLAN-DECK REINFORCEMENT

DESIGNED	GAE
CHECKED	JDA
DRAWN	NO
CHECKED	GAE

* Cut to fit. Use remainder in opposite Staged corner.
 Lap to existing reinforcement.
 ** Cut to fit.
 *** See sheet 6 of 10A for Exterior Parapet Elevation Joint Detail.

MIN. BAR LAP
 #15 bars = 510

SUPERSTRUCTURE PLAN
F.A.I. 55 OVER BUSINESS U.S. 51
SECTION (57-4)RS-3 & 1
McLEAN COUNTY
SN 057-0024 (NB)
SN 057-0025 (SB)
STA. 37+474.206

ROUTE NO.	SECTION	COUNTY	DATE	SHEET NO.
FAI 55		MCLEAN	07	62
FED. ROAD DIST. NO.	ILL. PROJ. NO.	FED. AID PROJECT NO.		

(57-4)RS-3 & 1

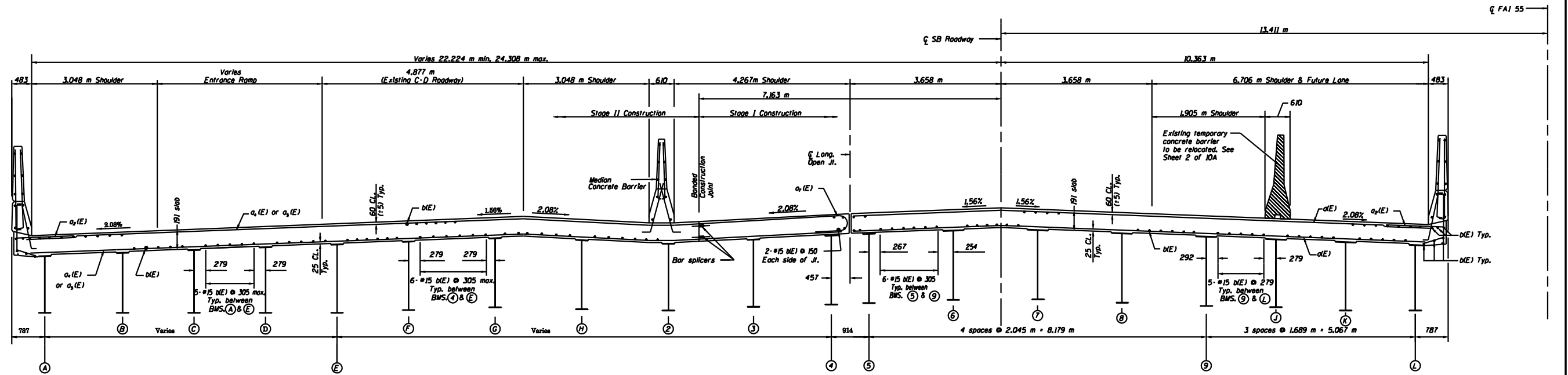

CROSS SECTION-DECK
SN 057-0025
(Looking East)

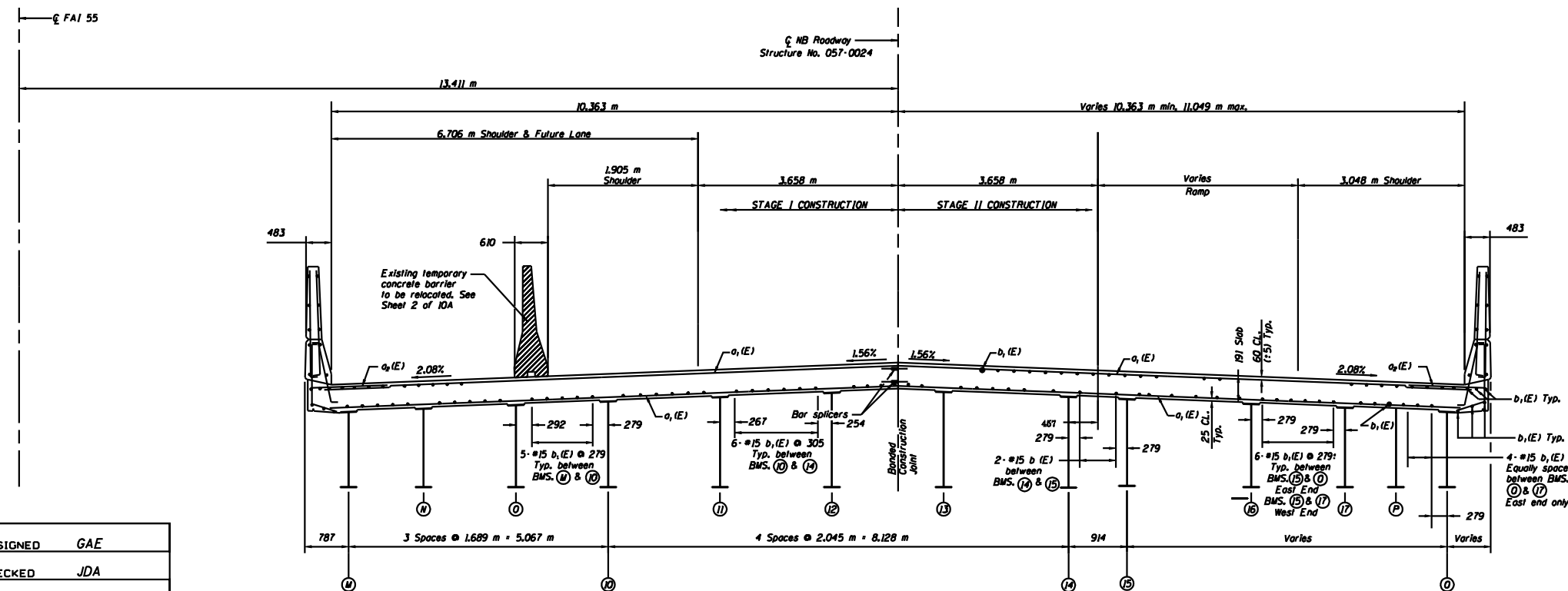

CROSS SECTION-DECK
SN 057-0024
(Looking East)

Notes:
See sheet 6 of IDA for Parapet reinforcement.
All dimensions are in millimeters (mm) except as noted.
Beam "P" will only be found in Span 4. (It does not extend full length of the Structure.)

DESIGNED	GAE
CHECKED	JDA
DRAWN	NO
CHECKED	GAE

SUPERSTRUCTURE DETAILS
F.A.I. 55 OVER BUSINESS U.S. 51
SECTION (57-4)RS-3 & 1
MCLEAN COUNTY
SN 057-0024 (NB)
SN 057-0025 (SB)
STA. 37+474.206

ROUTE NO.	SECTION	COUNTY	POST MILE	POST MILE	SHEET NO.
FAI 55		McLEAN	87	63	5
FED. ROAD DIST. NO. 7					10A SHEETS
ILL. PROJ. NO.					FED. AID PROJECT NO.

• (57-4)RS-3 & 1

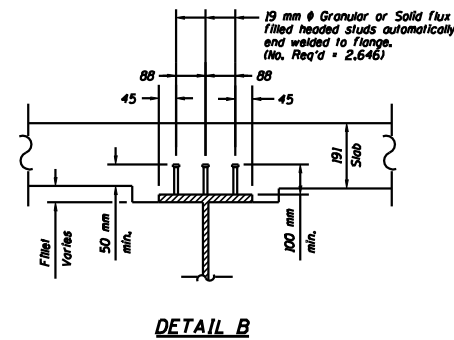
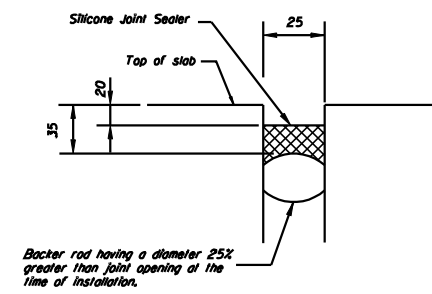
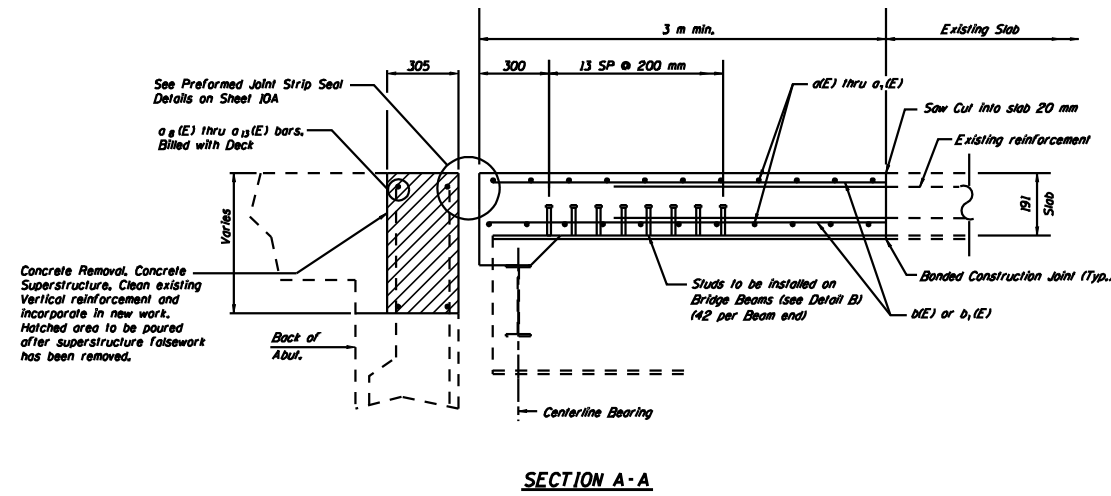

All dimensions are in millimeters (mm) except as noted.

DESIGNED	GAE
CHECKED	JDA
DRAWN	NO
CHECKED	GAE

SUPERSTRUCTURE DETAILS
F.A.I. 55 OVER BUSINESS U.S. 51
SECTION (57-4)RS-3 & 1
McLEAN COUNTY
SN 057-0024 (NB)
SN 057-0025 (SB)
STA. 37+474.206

ROUTE NO.	SECTION	COUNTY	SHEET NO.	10A SHEETS
FAI 55		MCLEAN	87	65
FED. ROAD DIST. NO. 7		ILL. HIGH.	FED. ROAD PROJECT	

• (57-4)RS-3 & 1

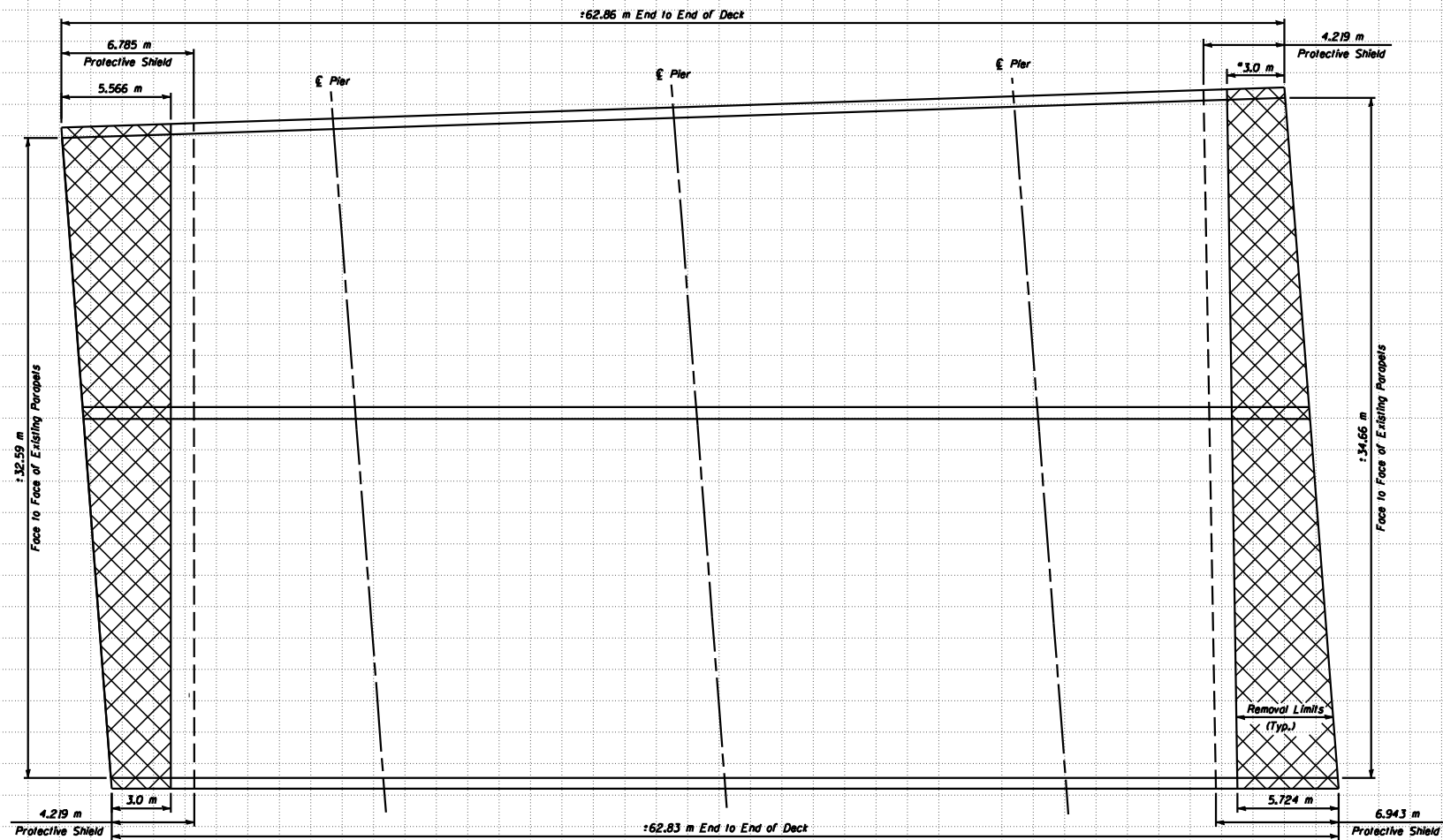

PLAN - TOP OF DECK
Existing Southbound Structure

* This portion of deck to be removed and replaced.

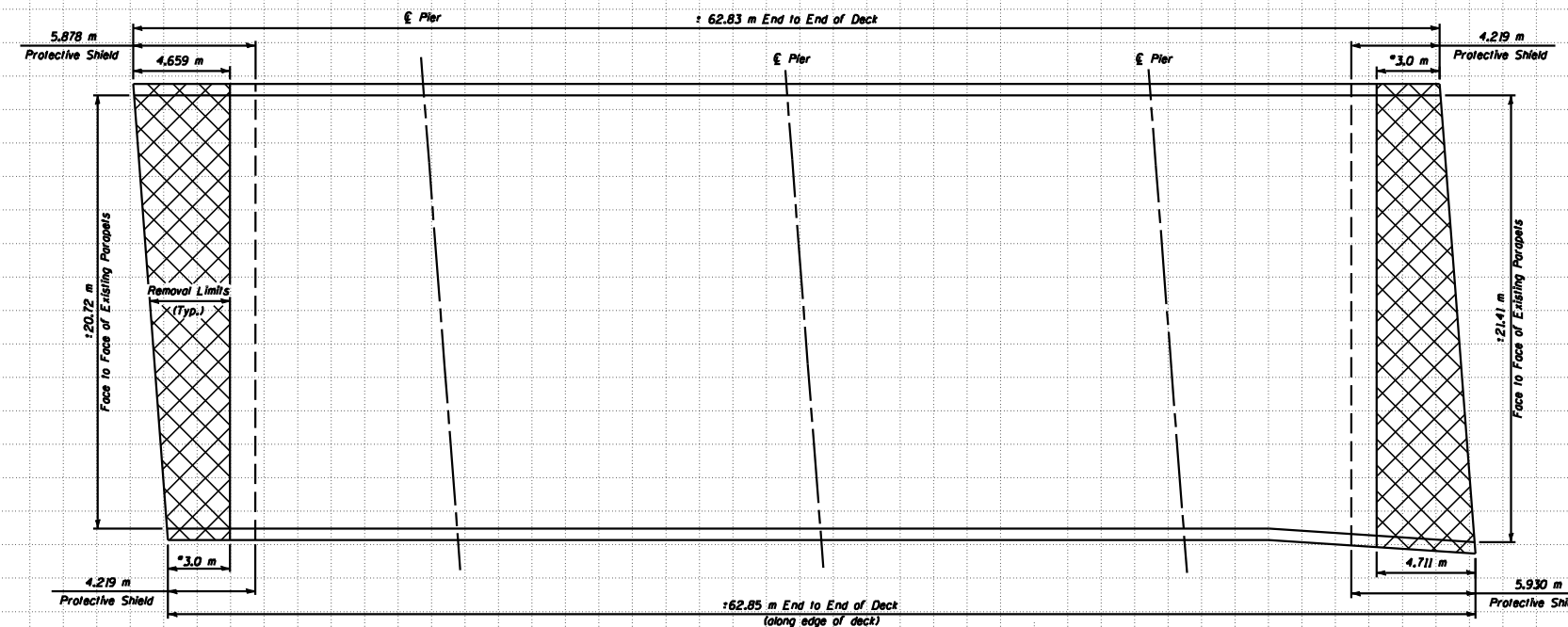

PLAN - TOP OF DECK
Existing Northbound Structure

Remove and Replace existing Bridge Deck See Sheet 3 & 4 of 10A for details

DESIGNED	GAE
CHECKED	JDA
DRAWN	NO
CHECKED	GAE

DECK REPAIR PLAN
F.A.I. 55 OVER BUSINESS U.S. 51
SECTION (57-4)RS-3 & 1
MCLEAN COUNTY
SN 057-0024 (NB)
SN 057-0025 (SB)
STA. 37+474.206

ROUTE NO.	SECTION	COUNTY	SHEET	NO.	SHEET NO.
FAI 55	*	MCLEAN	87	66	10A SHEETS
FED. ROAD DIST. NO. 1		NUMBER	FED. AID PROJECT		
* (57-4)RS-3 & 1					

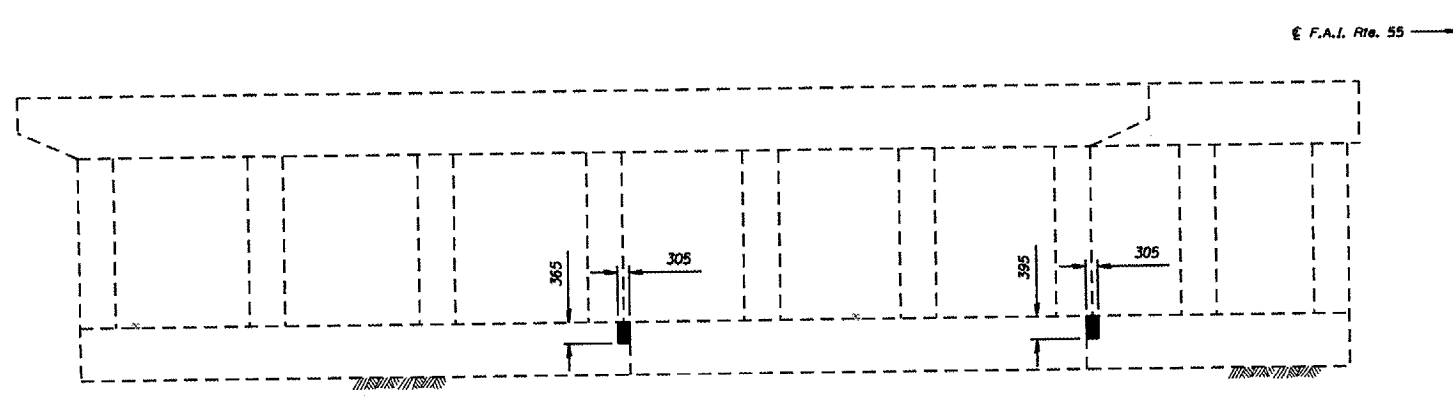

EXISTING PIER 2 WEST ELEVATION
(Southbound Lanes - Looking East)

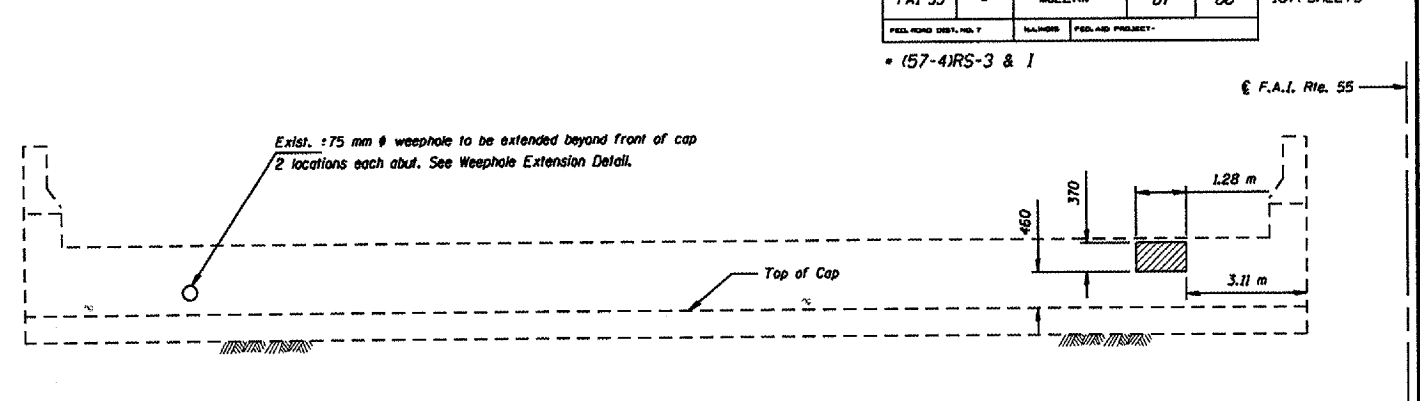

EXISTING EAST ABUTMENT ELEVATION
(Southbound Lanes)

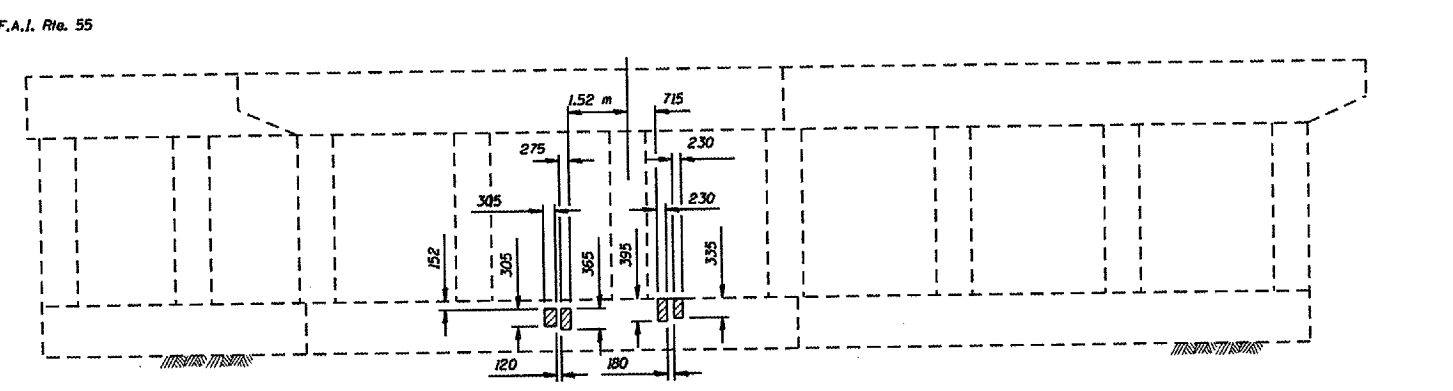

EXISTING PIER 2 EAST ELEVATION
(Southbound Lanes - Looking West)

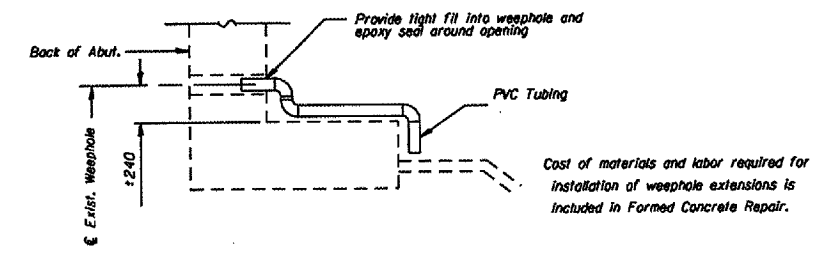

WEEP HOLE EXTENSION DETAIL
No. Required = 8

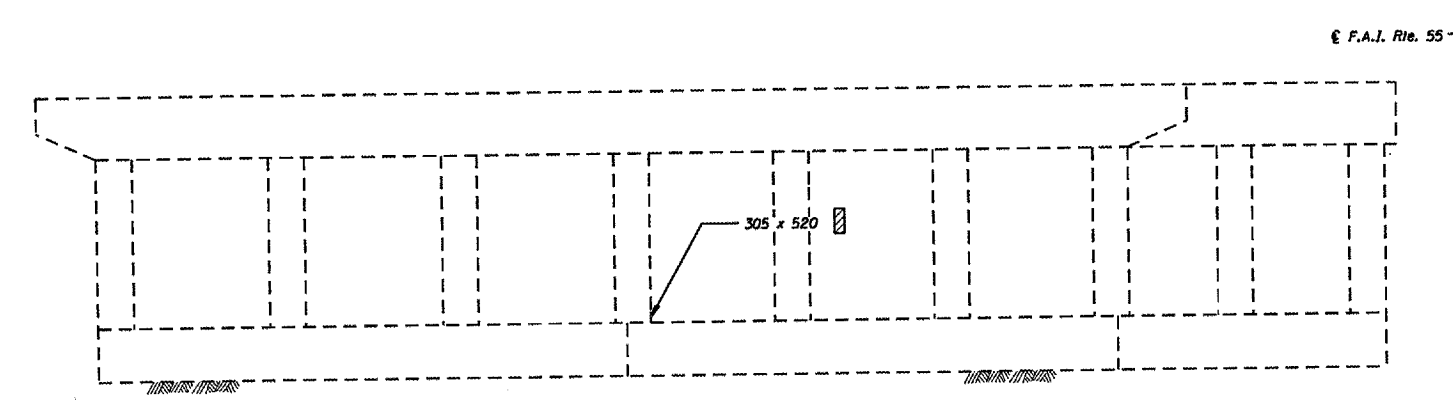

EXISTING PIER 3 WEST ELEVATION
(Southbound Lanes - Looking East)

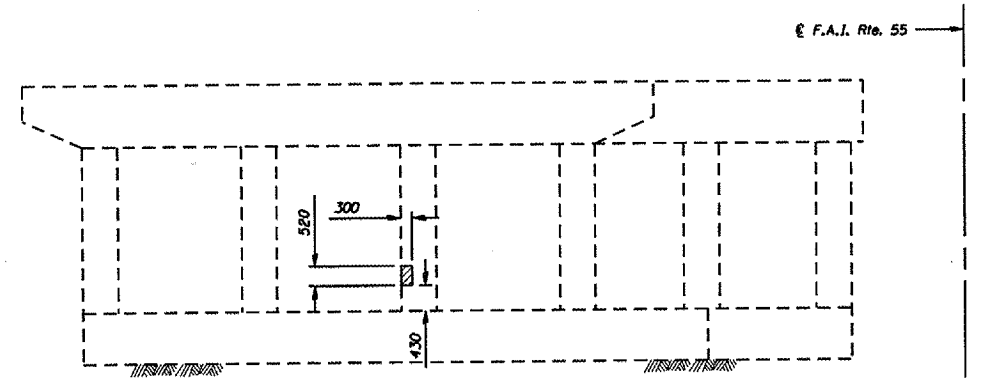

EXISTING PIER 4 EAST ELEVATION
(Northbound Lanes - Looking West)

All dimensions are in millimeters (mm) except as noted.

DESIGNED	GAE
CHECKED	JDA
DRAWN	NO
CHECKED	GAE

- Structural Repair of Concrete (Depth Equal to or Less Than 125 mm)
- Structural Repair of Concrete (Depth Greater Than 125 mm)

Notes:
Quantities for SLOPE WALL REPAIR, 39 50 M and SLOPE WALL 100M 39 50 M have been included for work at 3 locations to be determined by the Engineer.

Welded Wire Fabric 152 x 152 - MW25.8 x MW25.8 with a mass of 2.91 kg/m². A length of 150mm of existing welded wire around the removal area shall be exposed in order to lap with the proposed welded wire fabric.

BILL OF MATERIAL

Item	Unit	Quant.
Structural Repair of Concrete (Depth Equal to or Less Than 125 mm)	Sq M	1.2
Structural Repair of Concrete (Depth Greater Than 125 mm)	Sq M	0.2

FOUNDATION REPAIR DETAILS
F.A.I. 55 OVER BUSINESS U.S. 51
SECTION (57-4)RS-3 & 1
MCLEAN COUNTY
SN 057-0024 (NB)
SN 057-0025 (SB)
STA. 37+474.206

ROUTE NO.	SECTION	COUNTY	SHEET NO.	9
FAI 55	•	McLEAN	87	67
FED. ROAD DIST. NO. 7		ILL. HIGH.	FED. AID PROJECT.	

• (57-4)RS-3 & 1

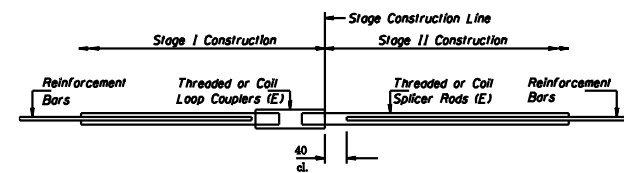

BAR SPLICER ASSEMBLY DETAIL

Bar Size	No. Assemblies Required	Location
#15	182	Slab
#20	16	Backwall

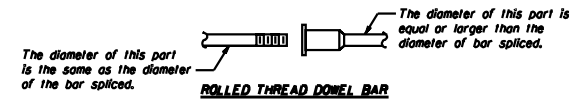

ROLLED THREAD DOWEL BAR

•• ONE PIECE

Wire Connector



WELDED SECTIONS

BAR SPLICER ASSEMBLY ALTERNATIVES

•• Heavy Hex Nuts conforming to ASTM A 563M, Grade C, D or DH may be used.

NOTES

Bar splicer assemblies shall be of an approved type and shall develop in tension at least 125 percent of the yield strength of the lapped reinforcement bars. Splicer rods shall be of minimum 400 MPa yield strength, threaded or coated full length. All reinforcement bars shall be lapped and tied to the splicer rods or dowel bars. Bar splicer assemblies shall be epoxy coated according to the requirements for reinforcement bars. Other systems of similar design may be submitted to the Engineer for approval. Approval shall be based on certified test results from an approved testing laboratory that the proposed bar splicer assembly satisfies the following requirements:

- Minimum Capacity = $1.25 \times 10^3 \times f_y \times A_s$
(Tension in kN)
- Minimum "Pull-out Strength" = $1.25 \times 10^3 \times f_{s,allow} \times A_s$
(Tension in kN)

Where f_y = Yield strength of lapped reinforcement bars in MPa.
 $f_{s,allow}$ = Allowable tensile stress in lapped reinforcement bars in MPa (Service Load)
 A_s = Tensile stress area of lapped reinforcement bars (mm²).
 * = 28 day concrete

Bar Size to be Spliced	Splicer Rod or Dowel Bar Length	Strength Requirements	
		Min. Capacity kN - tension	Min. Pull-Out Strength kN - tension
#15	610 mm	100	40
#20	790 mm	150	80
#25	1,04 m	250	100
#30	1,37 m	350	140

Bar splicer assemblies shall be according to Section 508 of the Standard Specifications, except as noted. The furnishing and installation of bar splicer assemblies will be measured and paid for at the contract unit price each for "BAR SPLICERS."
 All dimensions are in millimeters (mm) except as noted.

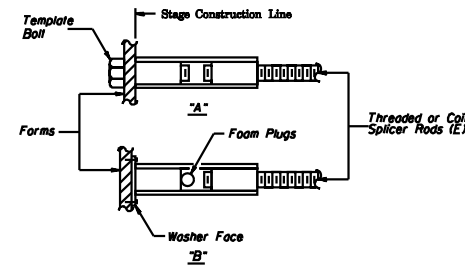

INSTALLATION AND SETTING METHODS

"A" = Set bar splicer assembly by means of a template bolt.
 "B" = Set bar splicer assembly by nailing to wood forms or cementing to steel forms.
 (E) = Indicates epoxy coating.

DESIGNED	GAE
CHECKED	JDA
DRAWN	NO
CHECKED	GAE

BAR SPLICER ASSEMBLY DETAILS
F.A.I. 55 OVER BUSINESS U.S. 51
SECTION (57-4)RS-3 & 1
McLEAN COUNTY
SN 057-0024 (NB)
SN 057-0025 (SB)
STA. 37+474.206

ROUTE NO.	SECTION	COUNTY	DATE	SHEET NO.
FAI 55		McLEAN	07	10
FED. ROAD DIST. NO. 7		ILL. PROJ.	FED. AID PROJECT	10A SHEETS

• (57-4)RS-3 & 1

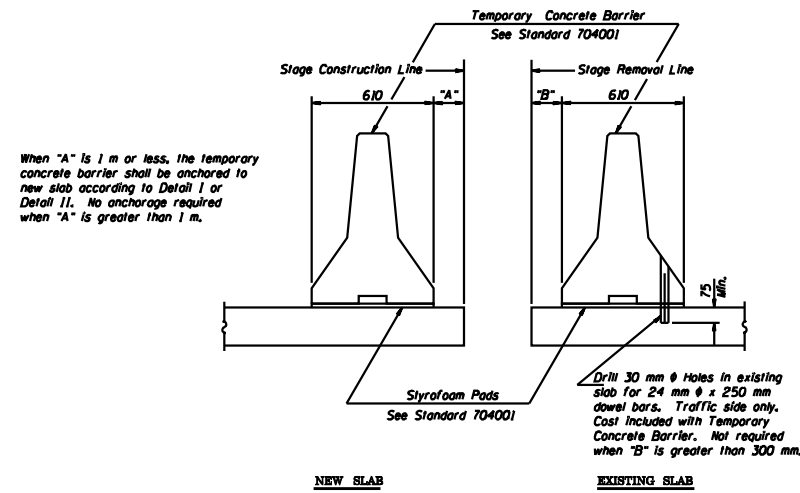

When "A" is 1 m or less, the temporary concrete barrier shall be anchored to new slab according to Detail I or Detail II. No anchorage required when "A" is greater than 1 m.

NOTES

- Detail I - With Bar Splicer or Couplers
Connect one (1) 25x180x250 steel \bar{E} to the top layer of couplers with 2-16 mm ϕ bolts screwed to coupler at approximate \bar{E} of each 3 m barrier panel.
 - Detail II - With Extended Reinforcement Bars
Connect one (1) 25x180x250 steel \bar{E} to the concrete slab with 2-16 mm ϕ Expansion Anchors or cast in place inserts spaced between the top layer of reinforcement at approximate \bar{E} of each 3 m barrier panel.
- Cost of anchorage included with Temporary Concrete Barrier.
All dimensions are in millimeters (mm) except as noted.

SECTION THRU SLAB

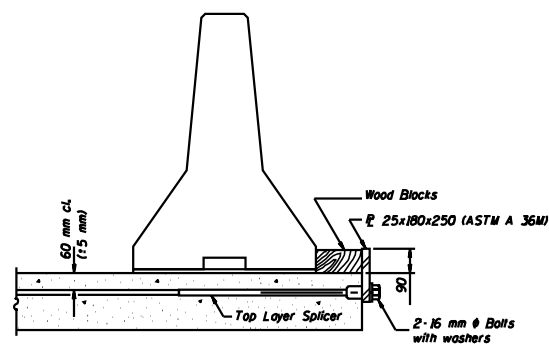

DETAIL I

The 25x180x250 Plate shall not be removed until Stage II Construction forms and reinforcement bars are in place.

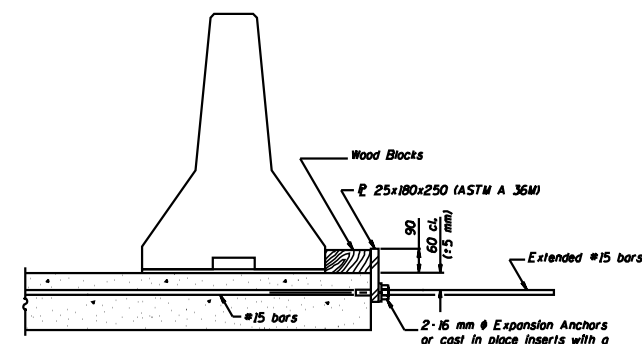

DETAIL II

The 25x180x250 Plate shall not be removed until Stage II Construction forms and all reinforcement bars are in place and the concrete is ready to be placed.

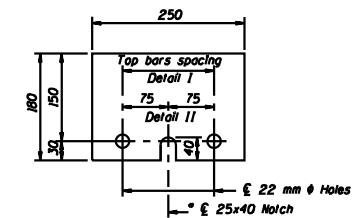

\bar{E} 25x180x250

* Required only with Detail II

DESIGNED	GAE
CHECKED	JDA
DRAWN	NO
CHECKED	GAE

TEMPORARY CONCRETE BARRIER
F.A.I. 55 OVER BUSINESS U.S. 51
SECTION (57-4)RS-3 & 1
McLEAN COUNTY
SN 057-0024 (NB)
SN 057-0025 (SB)
STA. 37+474.206

ROUTE NO.	SECTION	COUNTY	SHEET NO.	SHEET NO. 10A
FAJ 55		McLEAN	87	68A
FED. ROAD DIST. NO. 7	ILL. PROJ.	FED. AID PROJECT		10A SHEETS

* Granular or solid flux filled headed studs conforming to Article 1006.32 of the Std. Specs., automatically end welded.

** When joint is fixed, dimension is set at 40mm.

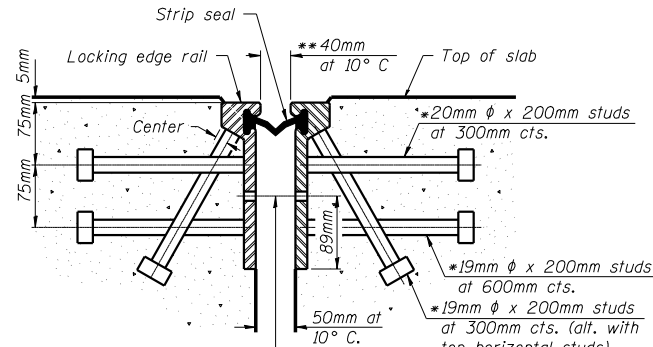

12mm ϕ holes at 1.22m cts. for 10mm ϕ bolts. All bolts shall be burned, sawed, or chipped off flush with the plates after forms are removed, typ.

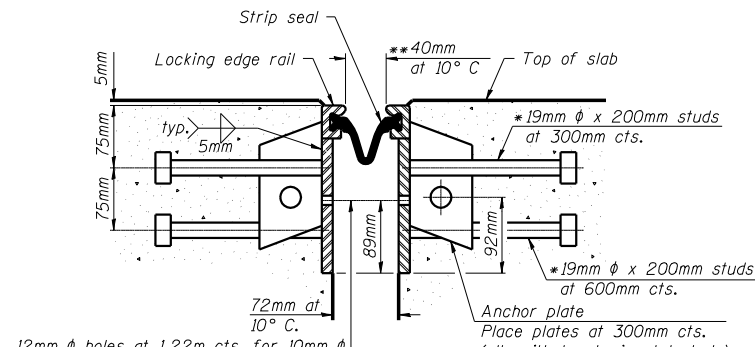

12mm ϕ holes at 1.22m cts. for 10mm ϕ bolts. All bolts shall be burned, sawed, or chipped off flush with the plates after forms are removed, typ.

Notes:

The strip seal shall be made continuous and shall have a minimum thickness of 5mm. The configuration of the strip seal shall match the configuration of the Locking Edge Rails. Open or "webbed" strip seal gland configurations are not permitted. The gland shall be sized for a maximum rated movement of 4 inches.

The height and thickness of the Locking Edge Rails shown are minimum dimensions. The actual configuration of the Locking Edge Rails and matching strip seal may vary from manufacturer to manufacturer. Flanged edge rails will not be allowed. Locking Edge Rails may be spliced at slope discontinuities and stage construction joints.

The manufacturer's recommended installation methods shall be followed. The joint opening and deck dimensions detailed on the superstructure are based on a rolled rail expansion joint. If the Contractor elects to use the welded rail expansion joint, the opening and deck dimensions shall be modified according to the dimensions detailed on this sheet. Required modifications shall be made at no additional cost to the State.

All steel components shall be galvanized after fabrication according to Article 520.03 of the Standard Specifications.

All dimensions are in millimeters (mm) except as noted.

SECTION THRU ROLLED RAIL JOINT

SECTION THRU WELDED RAIL JOINT

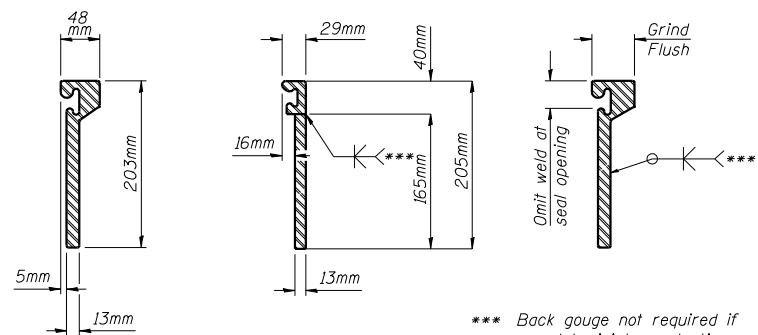

ROLLED (EXTRUDED) RAIL **WELDED RAIL**

*** Back gouge not required if complete joint penetration is verified by mock-up.

LOCKING EDGE RAIL SPLICE

The inside of the locking edge rail groove shall be free of weld residue.

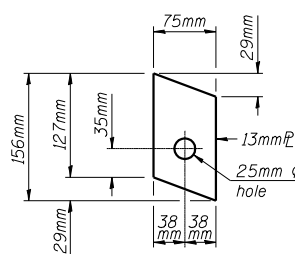

ANCHOR PLATE (for welded rail)

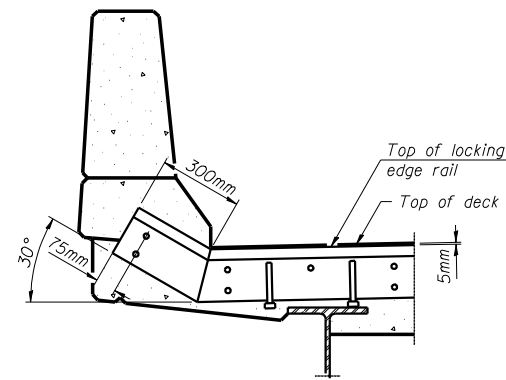

AT PARAPET

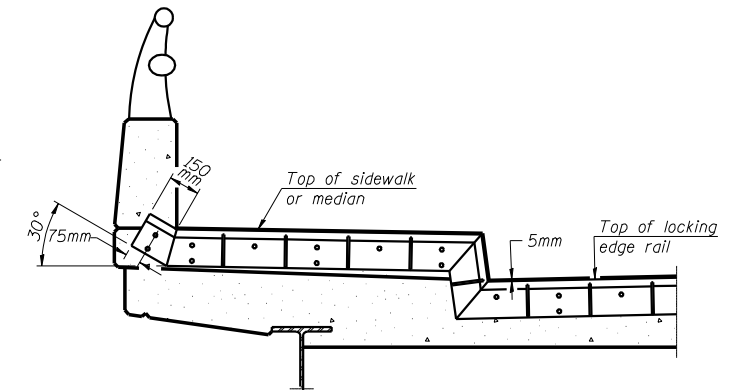

AT SIDEWALK OR MEDIAN

Shorter plates with a single row of studs at 300mm cts. may be necessary on medians which are shallower than 230mm. See manufacturer's recommendation.

TYPICAL END TREATMENTS

LOCKING EDGE RAILS

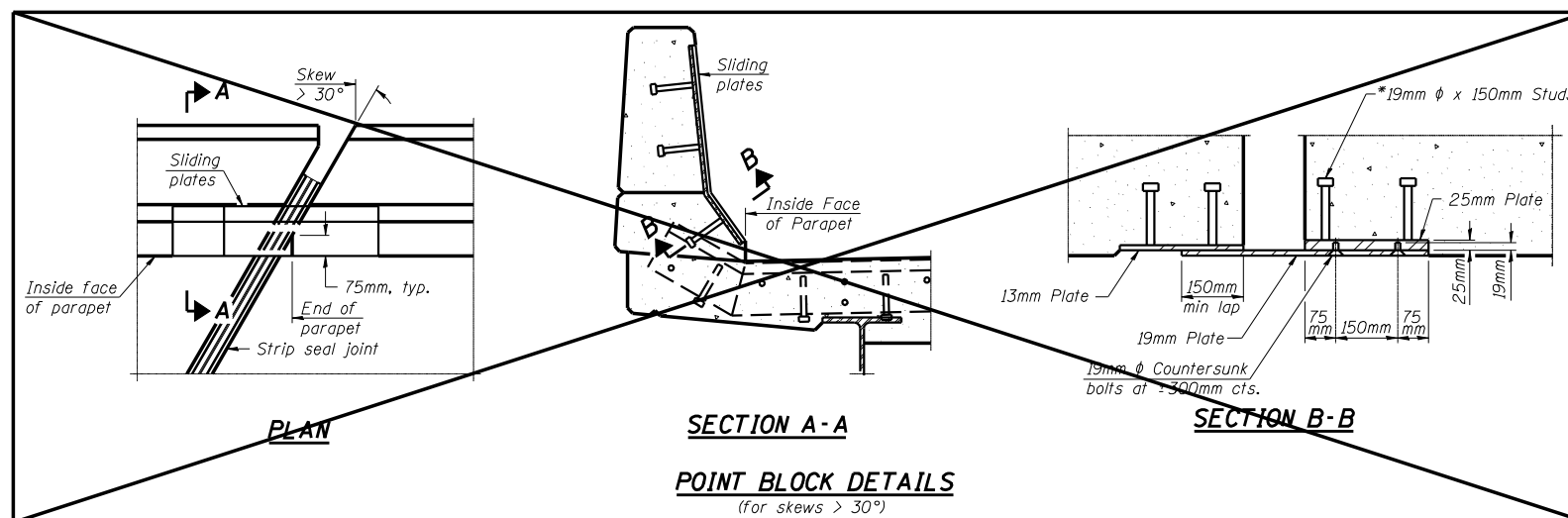

SECTION A-A

SECTION B-B

POINT BLOCK DETAILS (for skews > 30°)

DESIGNED	JDA
CHECKED	JKC
DRAWN	NO
CHECKED	JDA

200	EXAMINED
	PASSED
	ENGINEER OF BRIDGE DESIGN
	ENGINEER OF BRIDGES AND STRUCTURES

EJ-SSJ

11-1-06

BILL OF MATERIAL

Item	Unit	Total
Preformed Joint Strip Seal	Meter	112.2

**PREFORMED JOINT STRIP SEAL
F.A.I. 55 OVER BUSINESS U.S. 51
SECTION (57-4)RS-3 & 1
McLEAN COUNTY
SN 057-0024 (NB)
SN 057-0025 (SB)
STA. 37+474.206**

ROUTE NO.	SECTION	COUNTY	SHEET	TOTAL SHEETS
FAI 55		McLEAN	87	144
FED. ROAD DIST. NO. 7		ALLIANCE	FED. AID PROJECT	
• (57-4)RS-3 & 1				

Benchmark: MP-5 brass label set in concrete
Sta. 38+480.200 Elev. 270.21 m

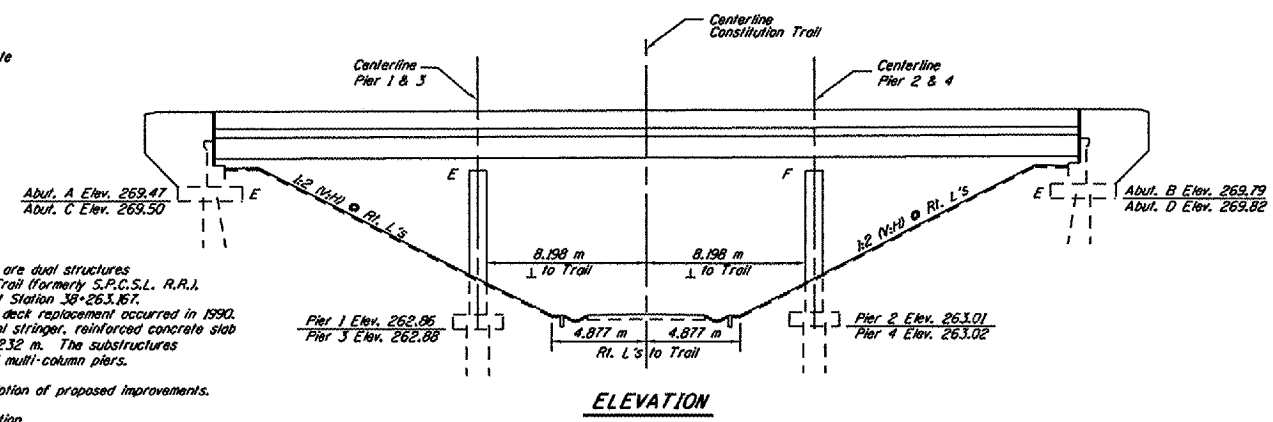

Existing Structures
Structure Number 057-0026 and 057-0027 are dual structures carrying F.A.I. 55 over Constitution Trail (formerly S.P.C.S.L. R.R.). Section (57-4) RS-3 & 1, McLean County of Station 38+263.167. Structures were built in 1962, widening and deck replacement occurred in 1990. The superstructures consist of 3 span, steel stringer, reinforced concrete slab deck with dk. to bk. abutment length of 46.232 m. The substructures consist of concrete pile bent abutments and multi-column piers.

See proposed work on this sheet for description of proposed improvements.
Traffic to be maintained by staged construction.

Proposed Work

1. Expansion joint removal and replacement.
2. Partial deck removal and replacement.
3. Add stud shear connectors at abutment ends of beams.
4. Remove existing expansion bearings of abutments and replace with elastomeric bearings.
5. Structural repair of concrete at abutments.

Item	Unit	Super	Sub.	Total
CONCRETE REMOVAL	CU M	93.6	0.7	93.6
PREFORMED JOINT STRIP SEAL	METER	87.3	--	87.3
CONCRETE SUPERSTRUCTURE	CU M	93.6	--	93.6
BRIDGE DECK GROOVING	SO M	332	--	332
PROTECTIVE COAT	SO M	406	--	406
STRUCTURAL REPAIR OF CONCRETE (DEPTH EQUAL TO OR LESS THAN 125 MM)	SO M	--	1.0	1.0
FURNISHING AND ERECTING STRUCTURAL STEEL	KG	3730	--	3730
REINFORCEMENT BARS, EPOXY COATED	KG	12870	--	12870
PROTECTIVE SHIELD	SO M	464	--	464
BAR SPLICERS	EACH	186	--	186
ELASTOMERIC BEARING ASSEMBLY, TYPE I	EACH	24	--	24
ELASTOMERIC BEARING ASSEMBLY TYPE II	EACH	24	--	24
STUD SHEAR CONNECTORS	EACH	2016	--	2016
JACK AND REMOVE EXISTING BEARINGS	EACH	48	--	48

General Notes

Reinforcement Bars designated (E) shall be Epoxy Coated.
All new structural steel shall be shop painted with an inorganic zinc rich primer per AASHTO M 300, Type I. Cost included with Furnishing and Erecting Structural Steel.
Field welding of construction accessories will not be permitted to beams or girders.
Plan dimensions and details relative to existing plans are subject to routine variations. The Contractor shall field verify existing dimensions and details affecting new construction and make necessary approved adjustments prior to construction or ordering of materials. Such variations shall not be cause for additional compensation for a change in scope of the work, however, the Contractor will be paid for the quantity actually furnished based upon the unit price bid for the work.

Prior to pouring the new concrete deck, all loose rust, loose mill scale, and all other loose potentially detrimental foreign material shall be removed from the surfaces of the beams or girders in contact with concrete. The cost of this work will be included in the pay item covering removal of existing concrete. All heavy rust and other highly adhered potentially detrimental foreign matter shall also be removed from the surfaces of the beams or girders in contact with concrete. Tightly adhered paint may remain unless otherwise noted. This removal shall be accomplished by methods that will not damage the steel. The cost of this work will be paid for according to Article 109.04.

All dimensions are in millimeters (mm) except as noted.

The existing structural steel coating contains lead. The Contractor shall take appropriate precautions to deal with the presence of lead on this project.

Reinforcement Bars shall conform to the requirements of ASTM A706 Grade 60 (IL. MOD.) See Special Provisions.

DESIGN STRESSES

EXISTING CONSTRUCTION
Concrete: f'c = 24 Mpa
Reinforcement: f_s (1962) = 138 Mpa
f_y (1990) = 400 Mpa
Structural Steel: f_s (1962) = 124 Mpa
f_y (1990) = 248 Mpa
Design Loading: MS18 & Alternate
Allow 1.2 kN/m for future wearing surface.
Design Specifications: AASHTO (1983) plus 1984 thru 1988 Interims.

DESIGN STRESSES

(NEW CONSTRUCTION)
Concrete: f'c = 24 Mpa
Reinforcement: f_y = 400 Mpa
Structural Steel: f_y = 248 Mpa
Design Specifications: AASHTO 2002 and Interims

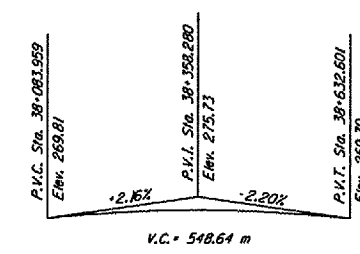
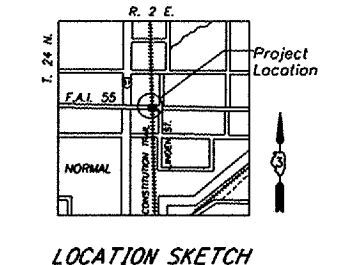
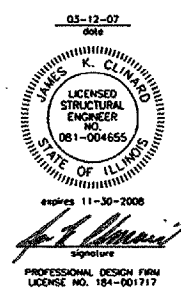

PROFILE GRADE F.A.I. 55

GENERAL PLAN AND ELEVATION
F.A.I. 55 OVER CONSTITUTION TRAIL
SECTION (57-4)RS-3 & 1
McLEAN COUNTY
SN 057-0026 (NB)
SN 057-0027 (SB)
STA. 38+263.167

CHAMLIN ASSOCIATES
PERU ILLINOIS MORRIS

Dimensions perpendicular to Centerline F.A.I. 55 and along End of Deck

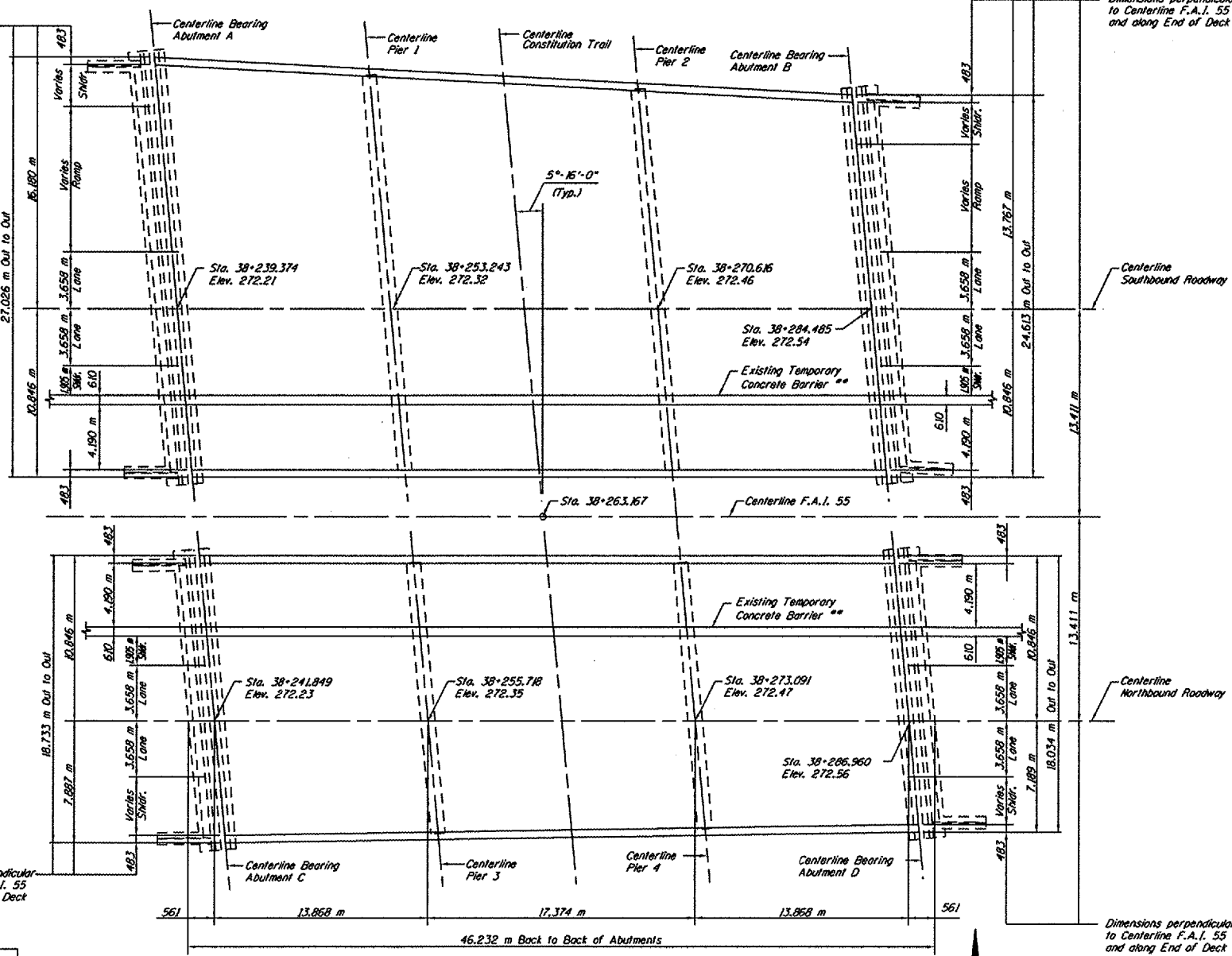

Dimensions perpendicular to Centerline F.A.I. 55 and along End of Deck

Centerline Southbound Roadway

Centerline Northbound Roadway

Dimensions perpendicular to Centerline F.A.I. 55 and along End of Deck

PLAN

DESIGNED	GAE
CHECKED	JDA
DRAWN	NO
CHECKED	GAE

** To be relocated
See sheet 2 of 14

ROUTE NO.	SECTION	COUNTY	DATE	SHEET NO.
FAI 55	*	MCLEAN	07 70	2
FED. ROAD DIST. NO. 7		ILL. HIGH.	FED. AID PROJECT	14A SHEETS

* (57-4)RS-3 & 1

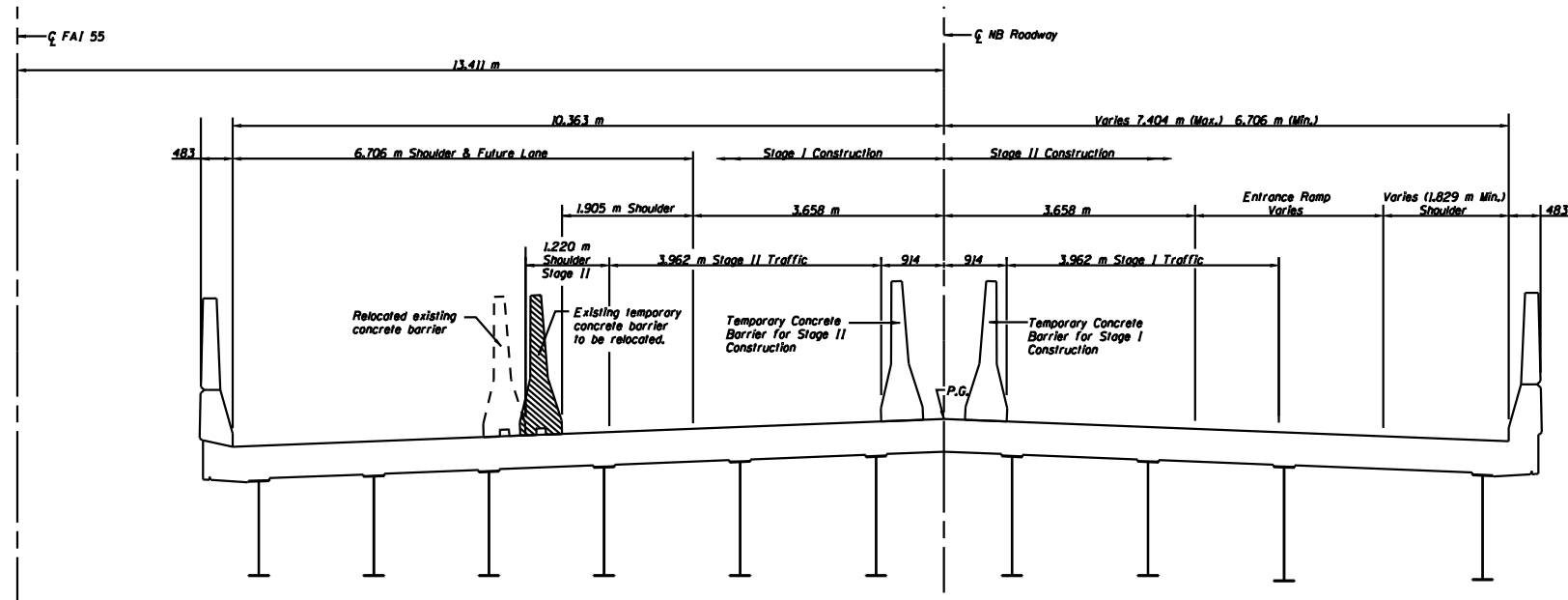

CROSS SECTION (SN 057-0026)
(Looking East)

Note:
All dimensions are in millimeters (mm) except as noted.

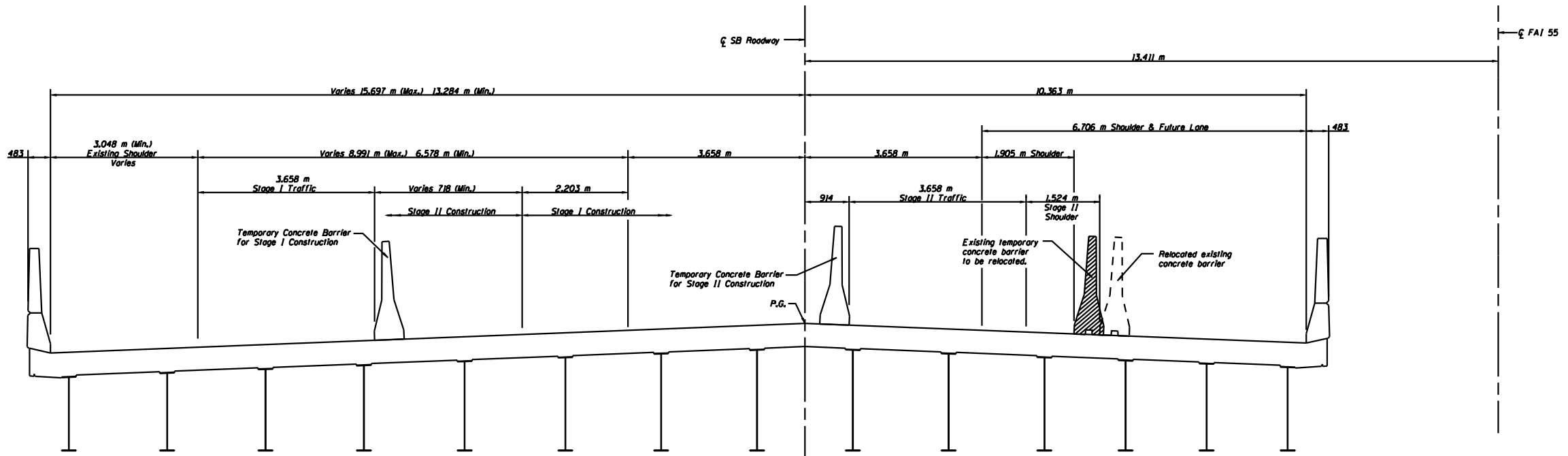

CROSS SECTION (SN 057-0027)
(Looking East)

** Location of barrier will vary as necessary to develop exit ramp

DESIGNED	GAE
CHECKED	JDA
DRAWN	NO
CHECKED	GAE

STAGE CONSTRUCTION DIAGRAM
F.A.I. 55 OVER CONSTITUTION TRAIL
SECTION (57-4)RS-3 & 1
MCLEAN COUNTY
SN 057-0026 (NB)
SN 057-0027 (SB)
STA. 38+263.167

ROUTE NO.	SECTION	COUNTY	DATE	SHEET NO.
FAI 55		MCLEAN	07	71
14A SHEETS				
FED. ROAD DIST. NO.	ILL. PROJ. NO.	FED. AID PROJECT		

• (57-4)RS-3 & I

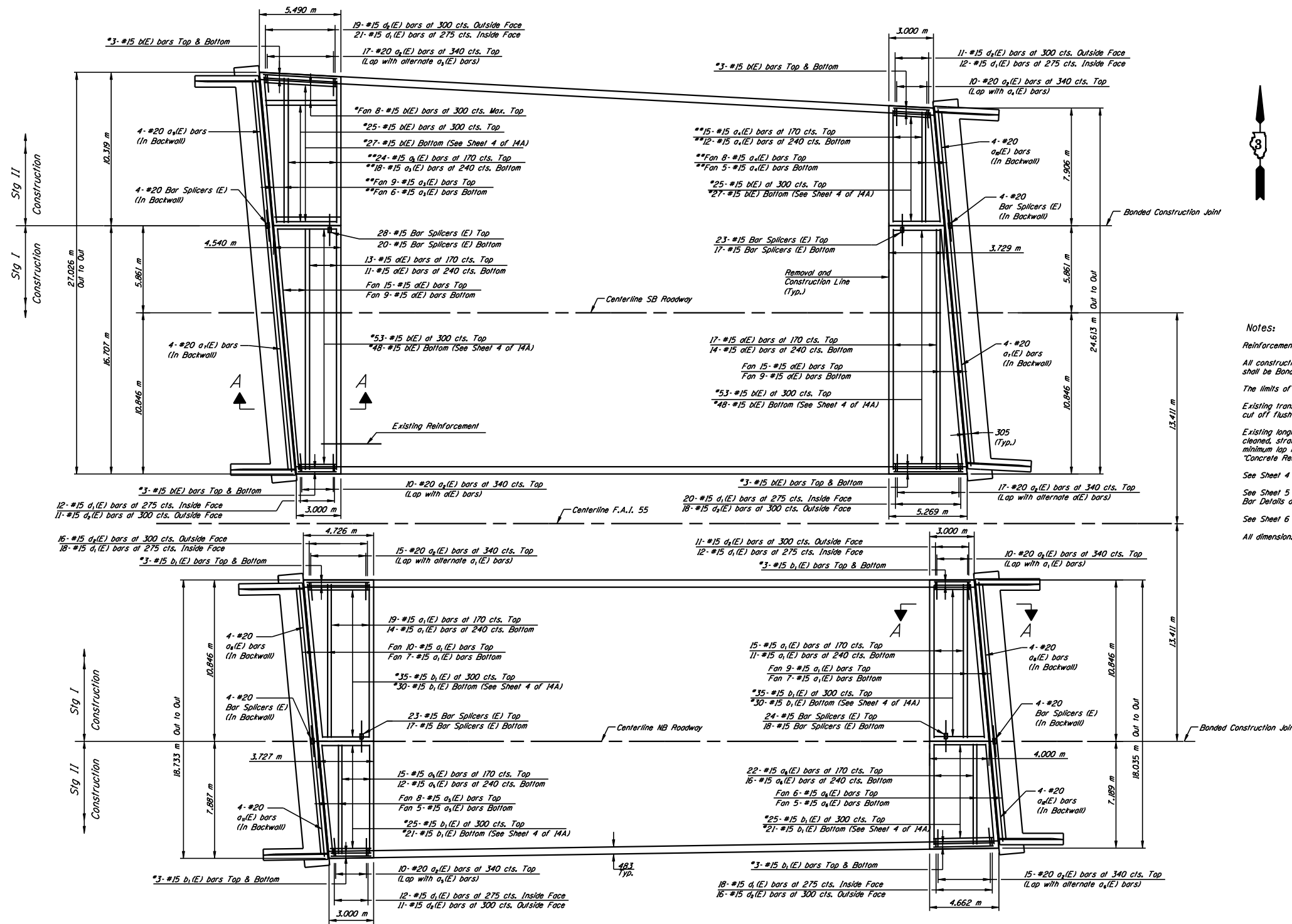

Notes:

- Reinforcement bars designated (E) shall be epoxy coated.
- All construction joints between new and existing construction shall be Banded Construction Joints.
- The limits of all concrete removal shall be cut 20 mm into concrete.
- Existing transverse reinforcement within the removal area shall be cut off flush with the removal line. Cost included with "Concrete Removal".
- Existing longitudinal reinforcement extending into removed areas shall be cleaned, straightened and incorporated into the new construction with a minimum lap length of 610 mm except as noted. Cost included with "Concrete Removal".
- See Sheet 4 of 14A for Cross Section thru deck.
- See Sheet 5 of 14A for Superstructure Details, Parapet Reinforcement, Bar Details and Bill of Material.
- See Sheet 6 of 14A for Section A-A.
- All dimensions are in millimeters (mm) except as noted.

PLAN-DECK REINFORCEMENT

DESIGNED	GAE
CHECKED	JDA
DRAWN	NO
CHECKED	GAE

* Cut to fit. Use remainder in opposite Staged corner. Lap to existing reinforcement.
 ** Cut to fit.
 MIN. BAR LAP
 #15 bars = 510

DECK REPAIR
F.A.I. 55 OVER CONSTITUTION TRAIL
SECTION (57-4)RS-3 & I
MCLEAN COUNTY
SN 057-0026 (NB)
SN 057-0027 (SB)
STA. 38+263.167

ROUTE NO.	SECTION	COUNTY	DATE	SHEET NO.
FAI 55		MCLEAN	07	72
FED. ROAD DIST. NO. 7		ILL. HIGH.	FED. AID PROJECT	

• (57-4)RS-3 & 1

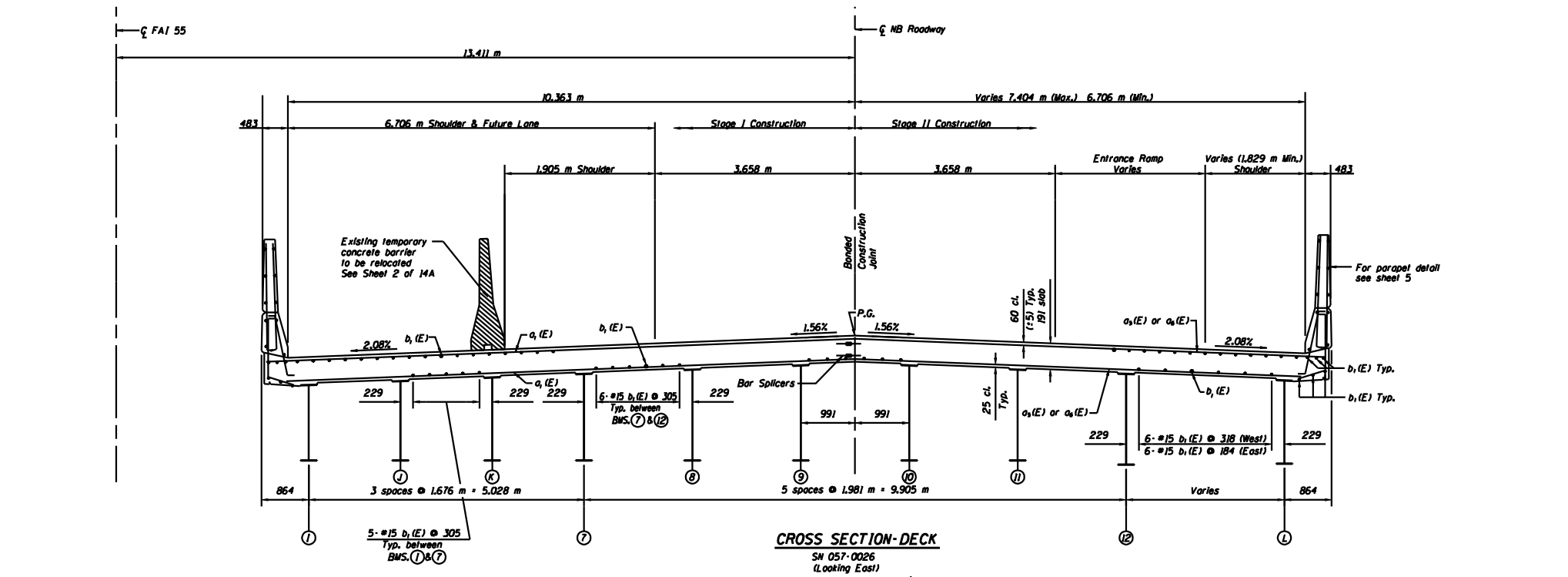

Notes:
See sheet 5 of 14A for Parapet reinforcement.
All dimensions are in millimeters (mm) except as noted.

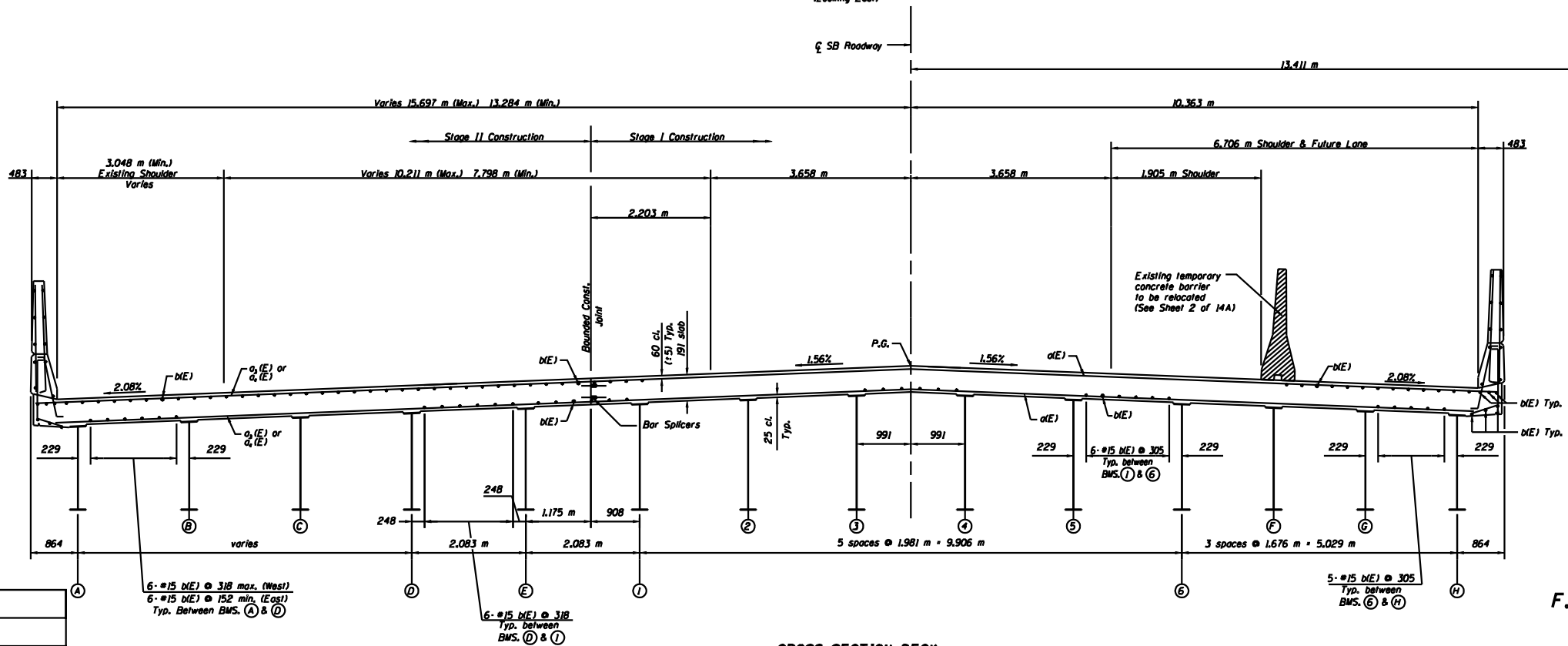

DESIGNED	GAE
CHECKED	JDA
DRAWN	NO
CHECKED	GAE

SUPERSTRUCTURE DETAILS
F.A.I. 55 OVER CONSTITUTION TRAIL
SECTION (57-4)RS-3 & 1
MCLEAN COUNTY
SN 057-0026 (NB)
SN 057-0027 (SB)
STA. 38+263.167

ROUTE NO.	SECTION	COUNTY	POST MILE	POST MILE	SHEET NO. 5
FAI 55	*	MCLEAN	87	73	14A SHEETS
FED. ROAD DIST. NO. 7		ILL. PROJ.	FED. AID PROJECT		

(57-4)RS-3 & 1

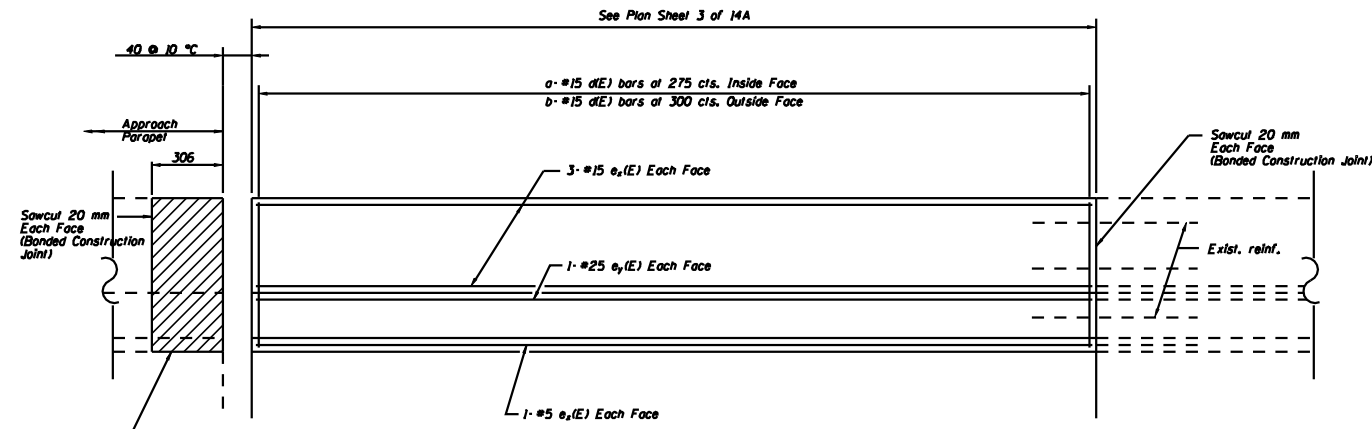

Concrete Removal, Concrete Superstructure,
(For Installation of Preformed Joint Strip Seal,
Clean and Straighten existing reinforcement and
incorporate in new work.)

EXTERIOR PARAPET ELEVATION
(Inside Face of North Parapet Shown)

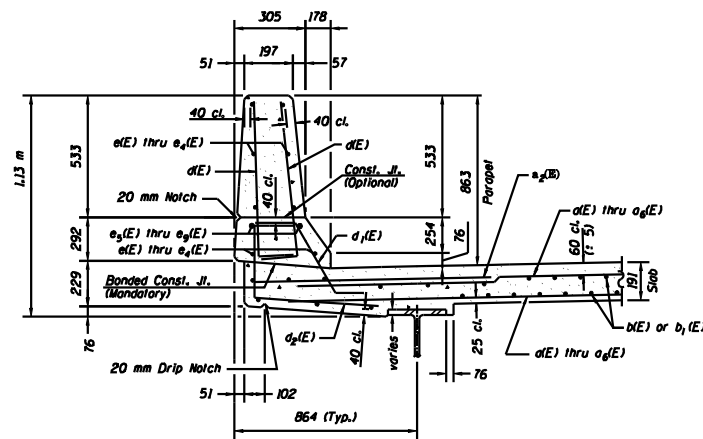

SECTION THRU EXTERIOR PARAPET

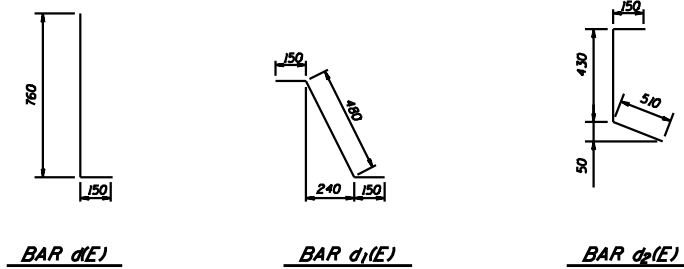

DESIGNED	GAE
CHECKED	JDA
DRAWN	NO
CHECKED	GAE

SOUTH BOUND ROADWAY

Location	a	b	x	y
Stage 1 SW Parapet	12	11	e1(E)	e3(E)
Stage 1 SE Parapet	20	18	e1(E)	e3(E)
Stage 2 NW Parapet	21	19	e3(E)	e3(E)
Stage 2 NE Parapet	12	11	e1(E)	e3(E)

NORTH BOUND ROADWAY

Location	a	b	x	y
Stage 1 NW Parapet	18	16	e2(E)	e1(E)
Stage 1 NE Parapet	12	11	e1(E)	e3(E)
Stage 2 SW Parapet	12	11	e1(E)	e3(E)
Stage 2 SE Parapet	18	16	e2(E)	e3(E)

BILL OF MATERIAL

SOUTH BOUND ROADWAY

Bar	Number		Size	Length (m)	Shape
	Stage 1	Stage 2			
d(E)	103	-	#15	16.60	---
d1(E)	27	27	#20	1.20	---
d2(E)	-	57	#15	10.22	---
d3(E)	-	40	#15	7.79	---
e1(E)	8	-	#20	16.65	---
e2(E)	-	4	#20	10.24	---
e3(E)	-	4	#20	7.81	---
b1(E)	107	66	#15	8.39	---
d(E)	61	63	#15	0.91	---
d1(E)	32	33	#15	0.78	---
d2(E)	29	30	#15	1.09	---
e1(E)	8	8	#15	2.90	---
e2(E)	8	-	#15	5.17	---
e3(E)	-	8	#15	5.39	---
e4(E)	2	2	#25	2.90	---
e5(E)	2	-	#25	5.17	---
e6(E)	-	2	#25	5.39	---
Reinforcement Bars, Epoxy Coated			kg	7690	
Concrete Superstructure			cu m	55.6	
Bar Splicers			each	96	

NORTH BOUND ROADWAY

Bar	Number		Size	Length (m)	Shape
	Stage 1	Stage 2			
d1(E)	92	-	#15	10.74	---
d2(E)	25	26	#20	1.20	---
d3(E)	-	40	#15	7.78	---
d4(E)	-	49	#15	7.08	---
d5(E)	8	-	#20	10.76	---
d6(E)	-	4	#20	7.79	---
d7(E)	-	4	#20	7.09	---
b1(E)	71	52	#15	7.63	---
d(E)	57	57	#15	0.91	---
d1(E)	30	30	#15	0.78	---
d2(E)	27	27	#15	1.09	---
e1(E)	8	8	#15	2.90	---
e2(E)	8	-	#15	4.63	---
e3(E)	-	8	#15	4.56	---
e4(E)	2	2	#25	2.90	---
e5(E)	2	-	#25	4.63	---
e6(E)	-	2	#25	4.56	---
Reinforcement Bars, Epoxy Coated			kg	5180	
Concrete Superstructure			cu m	38.0	
Bar Splicers			each	90	

**STRUCTURAL DETAILS &
BILL OF MATERIALS
F.A.I. 55 OVER CONSTITUTION TRAIL
SECTION (57-4)RS-3 & 1
MCLEAN COUNTY
SN 057-0026 (NB)
SN 057-0027 (SB)
STA. 38+263.167**

ROUTE NO.	SECTION	COUNTY	SHEET NO.	SHEET NO.
FAJ 55		MCLEAN	87	74
FED. ROAD DIST. NO. 7		ILL. HIGH.	FED. AID PROJECT	

14A SHEETS

• (57-4)RS-3 & 1

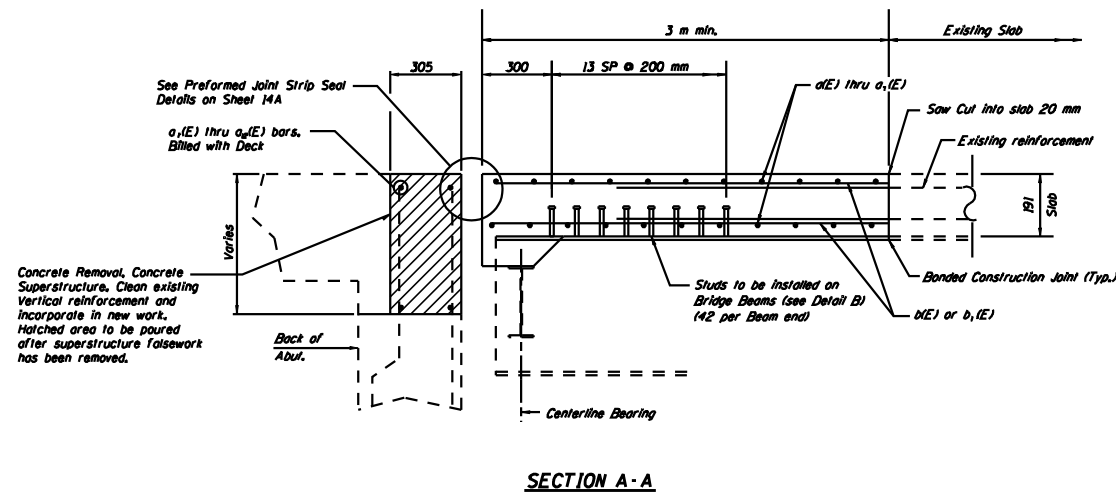

SECTION A-A

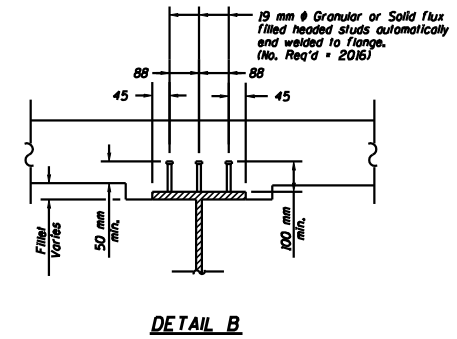

DETAIL B

All dimensions are in millimeters (mm) except as noted.

DESIGNED	GAE
CHECKED	JDA
DRAWN	NO
CHECKED	GAE

EXPANSION JOINT REPLACEMENT DETAILS
 F.A.I. 55 OVER CONSTITUTION TRAIL
 SECTION (57-4)RS-3 & 1
 MCLEAN COUNTY
 SN 057-0026 (NB)
 SN 057-0027 (SB)
 STA. 38+263.167

ROUTE NO.	SECTION	COUNTY	DATE	SHEET NO.
FAI 55		MCLEAN	07 75	7
FED. ROAD DIST. NO. 7		ILL. PROJ. NO.	FED. AID PROJECT NO.	14A SHEETS

• (57-4)RS-3 & 1

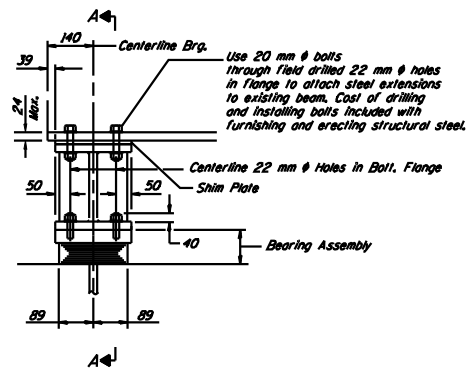

ELEVATION

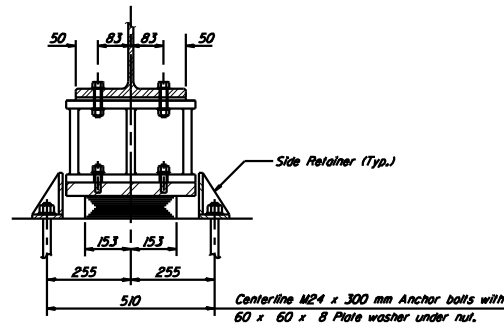

SECTION A-A

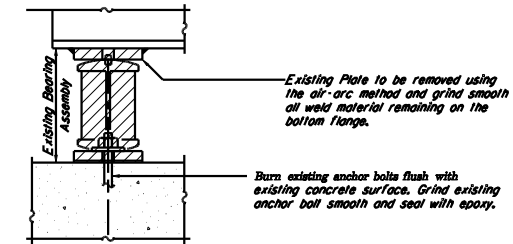

EXISTING BEARING REMOVAL DETAIL

Cost is included with "Jack and Remove Existing Bearings".

TYPE I ELASTOMERIC EXP. BRG.
(Cost Abut. B & D)

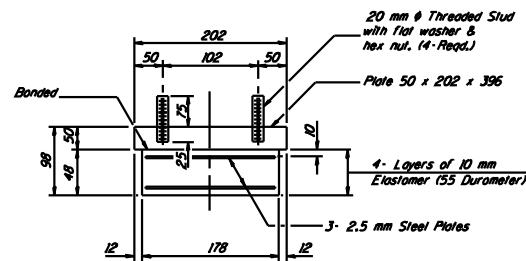

BEARING ASSEMBLY

Note: Shim plates shall not be placed under Bearing Assembly.

BEAM REACTIONS

(All Abutments)

BR	(KN)	76
RL	(KN)	172
Imp.	(KN)	50
R (Total)	(KN)	298

Min. Jack Capacity: 281 kN

Notes: Diaphragm removal and replacement may be required to facilitate drilling holes. Cost shall be included in the cost of Furnishing and Erecting Structural Steel.
New steel extensions, side retainers, shim R's, connection bolts, and anchor bolts are included in Furnishing and Erecting Structural Steel.
See Sheet #4 of 14A for Anchor Bolt Installation.
All dimensions are in millimeters (mm) except as noted.
Prior to ordering any material, the Contractor shall verify in the field all bearing height and shim thickness dimensions.

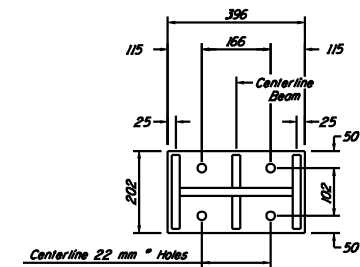

TOP & BOTTOM PLAN STEEL EXTENSION

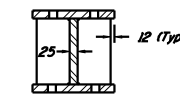

SECTION B-B

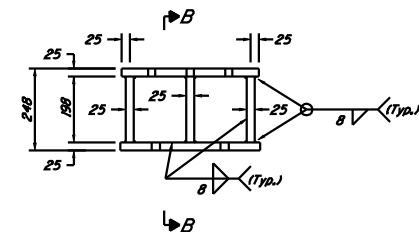

ELEVATION STEEL EXTENSION

STEEL EXTENSION DETAILS

24 Required at Abutments B & D

Note: Contractor shall field measure existing bearings and provide 202 x 266 shims as necessary.

BILL OF MATERIAL

Item	Unit	Total
Elastomeric Bearing Assembly Type I	Each	24
Furnishing and Erecting Structural Steel	kg	1820
Jack and Remove Existing Bearing	Each	24

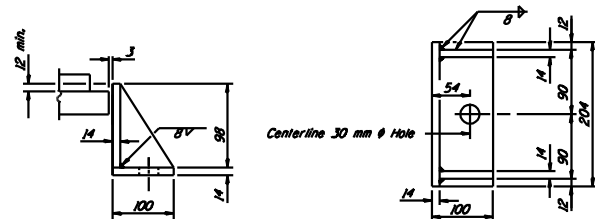

SIDE RETAINER

Equivalent rolled angle with stiffeners will be allowed in lieu of welded plates. Weight included with Structural Steel. (No. Req'd 48 @ Abutments B & D)

DESIGNED	GAE
CHECKED	JDA
DRAWN	NO
CHECKED	GAE

BEARING DETAILS ABUTS. B & D
F.A.I. 55 OVER CONSTITUTION TRAIL
SECTION (57-4)RS-3 & 1
MCLEAN COUNTY
SN 057-0026 (NB)
SN 057-0027 (SB)
STA. 38+263.167

ROUTE NO.	SECTION	COUNTY	DATE	SHEET NO.
FAJ 55	*	MCLEAN	07	76
FED. ROAD DIST. NO. 7		ILL. HIGH.	FED. AID PROJECT	14A SHEETS

• (57-4)RS-3 & 1

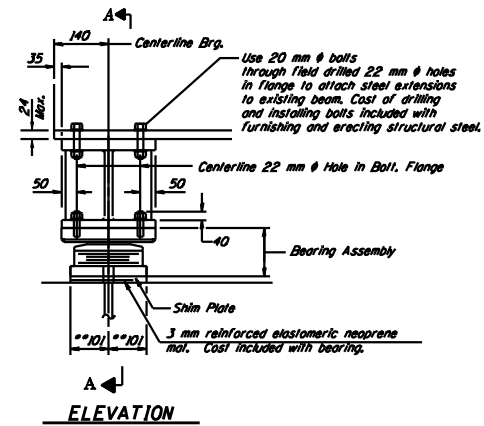

TYPE II ELASTOMERIC EXP. BRG.
(West Abut. A & C)

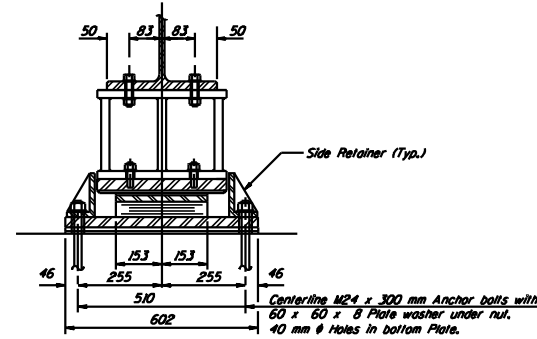

Notes: Diaphragm removal and replacement may be required to facilitate drilling holes. Cost shall be included in the cost of Furnishing and Erecting Structural Steel.
New steel extensions, side retainers, shim E's, connection bolts, and anchor bolts are included in Furnishing and Erecting Structural Steel.
See Sheet 14 of 14A for Anchor Bolt Installation.
All dimensions are in millimeters (mm) except as noted. Prior to ordering any material, the Contractor shall verify in the field all bearing height and shim thickness dimensions.

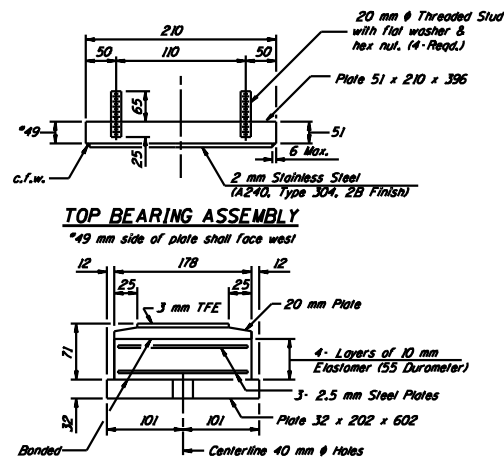
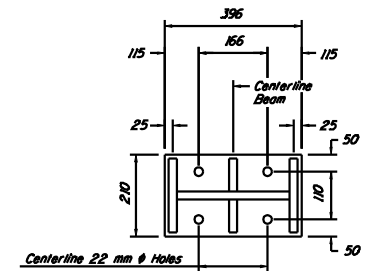

TOP BEARING ASSEMBLY
*49 mm side of plate shall face west

BOTTOM BEARING ASSEMBLY

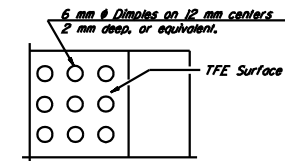

PLAN-TFE SURFACE

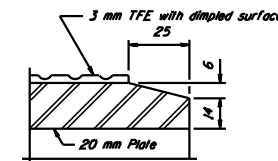

SECTION THRU TFE

Notes: The 3 mm TFE sheet shall be bonded directly to the top steel plate with a two-component, medium viscosity epoxy resin, conforming to the requirements of the Federal Specification MMM-A-134, Type 1. The bond agent shall be applied on the full area of the contact surfaces. Bonding of 3 mm TFE sheet during vulcanizing process will be permitted provided the process and method of adjusting assembly height is approved by the Engineer.

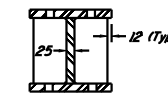

SECTION B-B

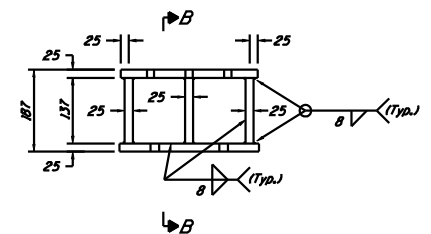

STEEL EXTENSION DETAILS

24 Required at Abutments A & C

BILL OF MATERIAL

Item	Unit	Total
Elastomeric Bearing Assembly Type II	Each	24
Furnishing and Erecting Structural Steel	kg	1810
Jack and Remove Existing Bearing	Each	24

Note: Contractor shall field measure existing bearings and provide 202 x 602 shims as necessary.

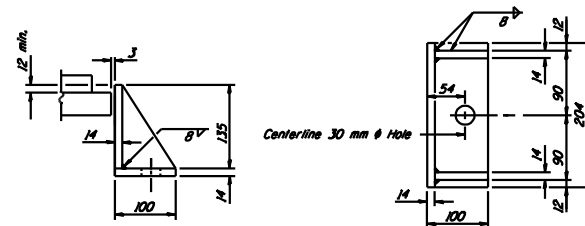

SIDE RETAINER
Equivalent rolled angle with stiffeners will be allowed in lieu of welded plates. Weight included with Structural Steel. (No. Req'd 48 @ Abutments A & C)

DESIGNED	GAE
CHECKED	JDA
DRAWN	NO
CHECKED	GAE

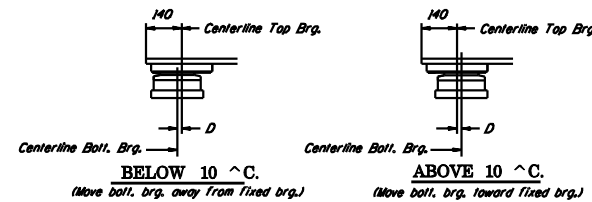

**** SETTING ANCHOR BOLTS AT EXP. BRG.**

D = 1 mm per each 10 m of expansion for every 8 $^{\circ}$ C temp. change from the normal temp. of 10 $^{\circ}$ C.

BEARING DETAILS ABUTS. A & C
F.A.I. 55 OVER CONSTITUTION TRAIL
SECTION (57-4)RS-3 & 1
MCLEAN COUNTY
SN 057-0026 (NB)
SN 057-0027 (SB)
STA. 38+263.167

ROUTE NO.	SECTION	COUNTY	DATE	SHEET NO.
FAI 55	*	MCLEAN	07	77
FED. ROAD DIST. NO. 7		ILL. HIGH.	FED. AID PROJECT	

14A SHEETS

* 157-41RS-3 & 1

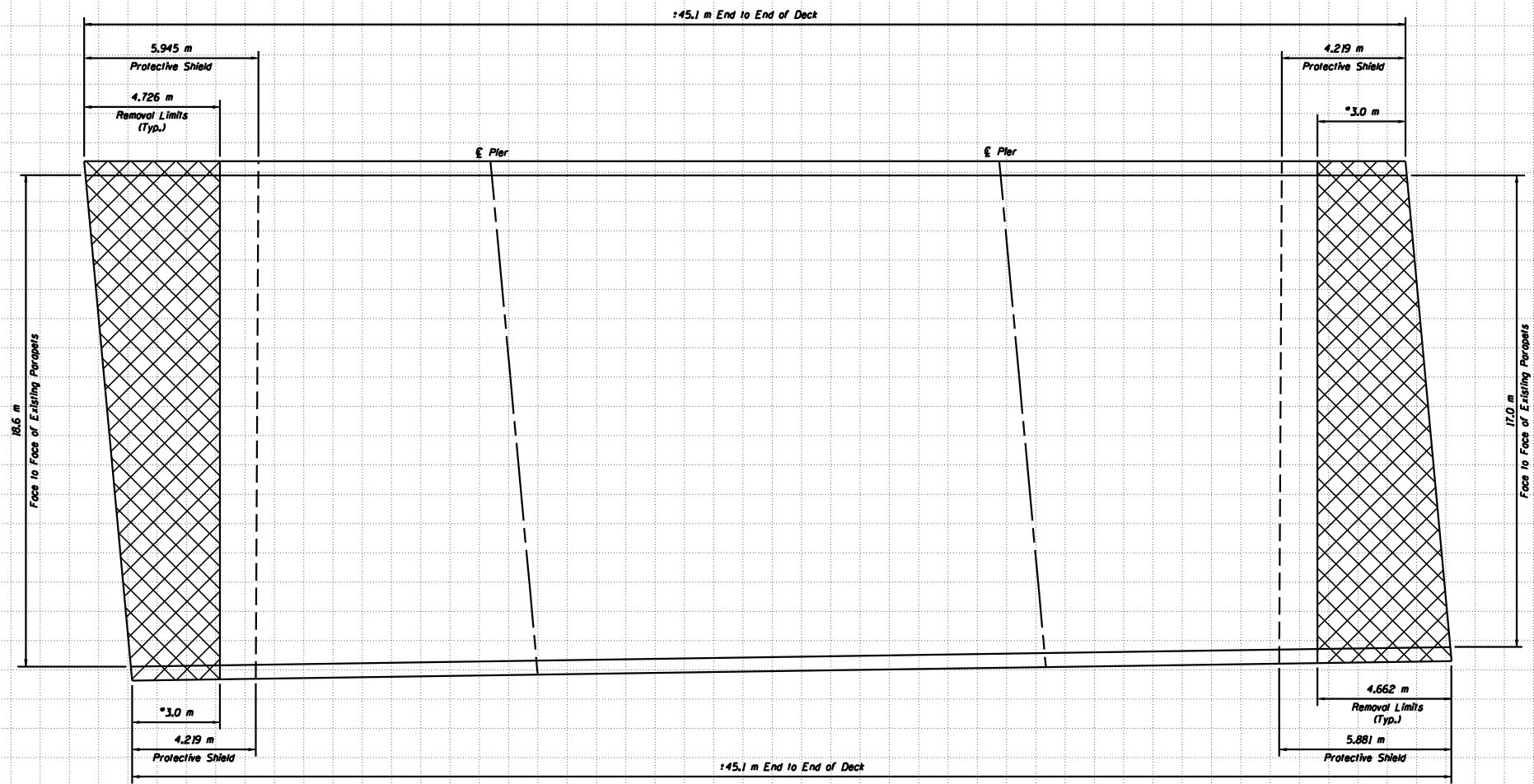

* This portion of deck to be removed & replaced.

PLAN - TOP OF DECK

SN 057-026 (NB)



Remove and Replace existing Bridge Deck See Sheet 3 & 4 of 14A for details

DESIGNED	GAE
CHECKED	JDA
DRAWN	NO
CHECKED	GAE

DECK REPAIR PLAN
F.A.I. 55 OVER CONSTITUTION TRAIL
SECTION (57-4)RS-3 & 1
MCLEAN COUNTY
SN 057-0026 (NB)
SN 057-0027 (SB)
STA. 38+263.167

ROUTE NO.	SECTION	COUNTY	DATE	SHEET NO.
FAI 55	*	MCLEAN	07	78
FED. ROAD DIST. NO. 7		ILL. HIGH.	FED. AID PROJECT	

14A SHEETS

* (57-4)RS-3 & 1

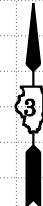
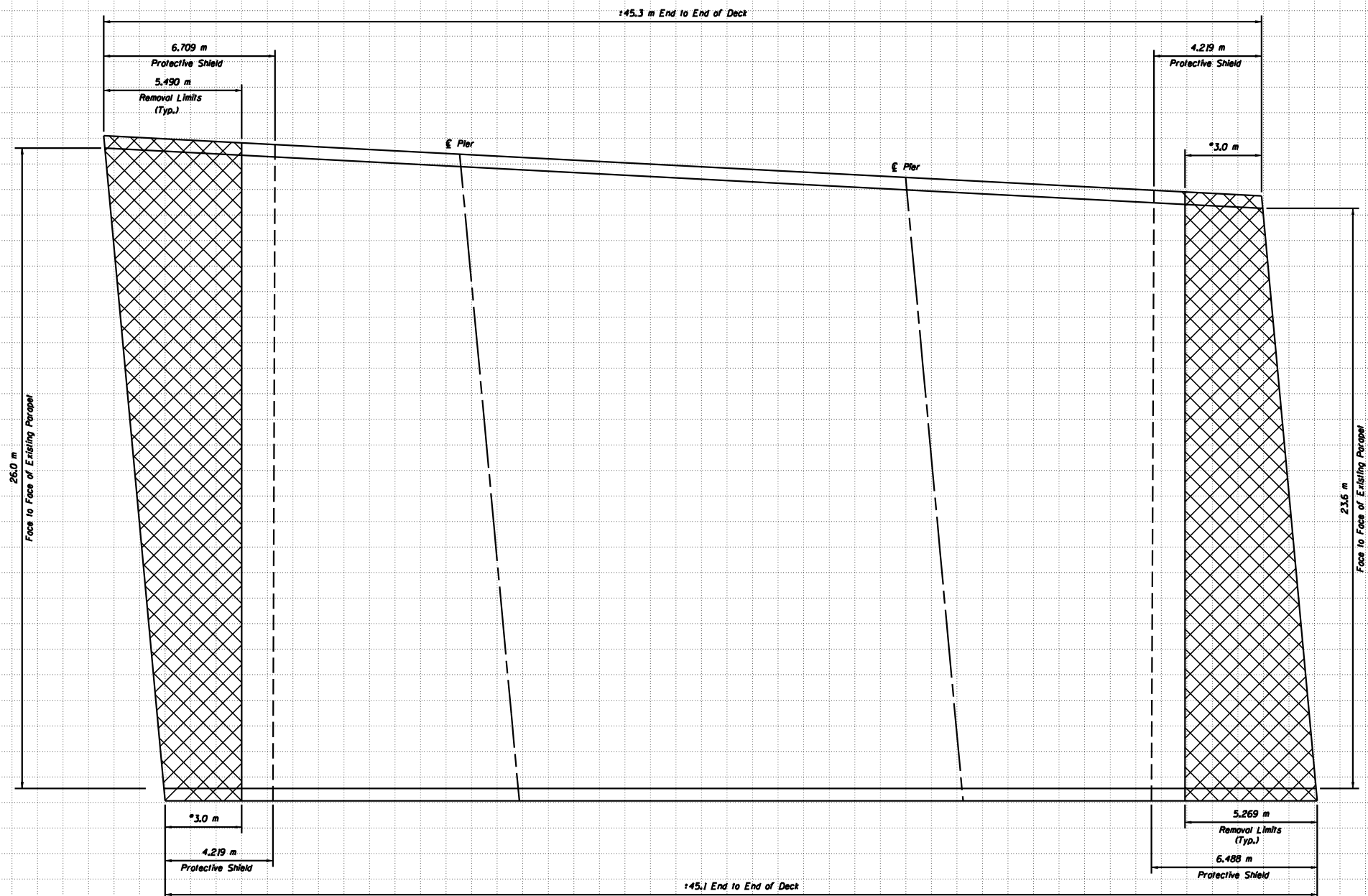

 Remove and Replace existing Bridge Deck See Sheet 3 & 4 of 14A for details.

DESIGNED	GAE
CHECKED	JDA
DRAWN	NO
CHECKED	GAE

PLAN - TOP OF DECK

SN 057-027 (SB)

DECK REPAIR PLAN
F.A.I. 55 OVER CONSTITUTION TRAIL
SECTION (57-4)RS-3 & 1
MCLEAN COUNTY
SN 057-0026 (NB)
SN 057-0027 (SB)
STA. 38+263.167

ROUTE NO.	SECTION	COUNTY	DATE	SHEET NO.
FAI 55	*	MCLEAN	07	79
FED. ROAD DIST. NO. 7		ILL. HIGH.	FED. AID PROJECT	

14A SHEETS

* (57-4)RS-3 & 1

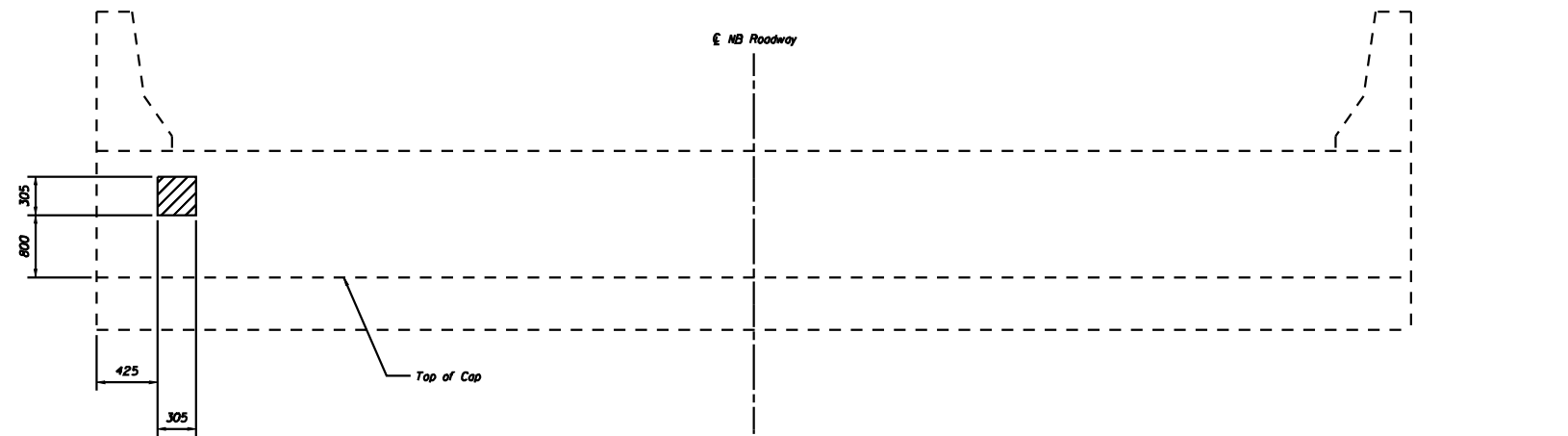

EXISTING WEST ABUTMENT ELEVATION

SN 057-026 (NB)

LEGEND

Structural Repair of Concrete
(Depth Equal to or Less than 125 mm)

TOTAL BILL OF MATERIALS		
Item	Unit	Quantity
Structural Repair of Concrete (Depth Equal to or Less Than 125 mm)	Sq M	1.0

Note: Diaphragm removal and replacement may be required to facilitate repair. Cost shall be included in the cost of Structural Repair of Concrete.

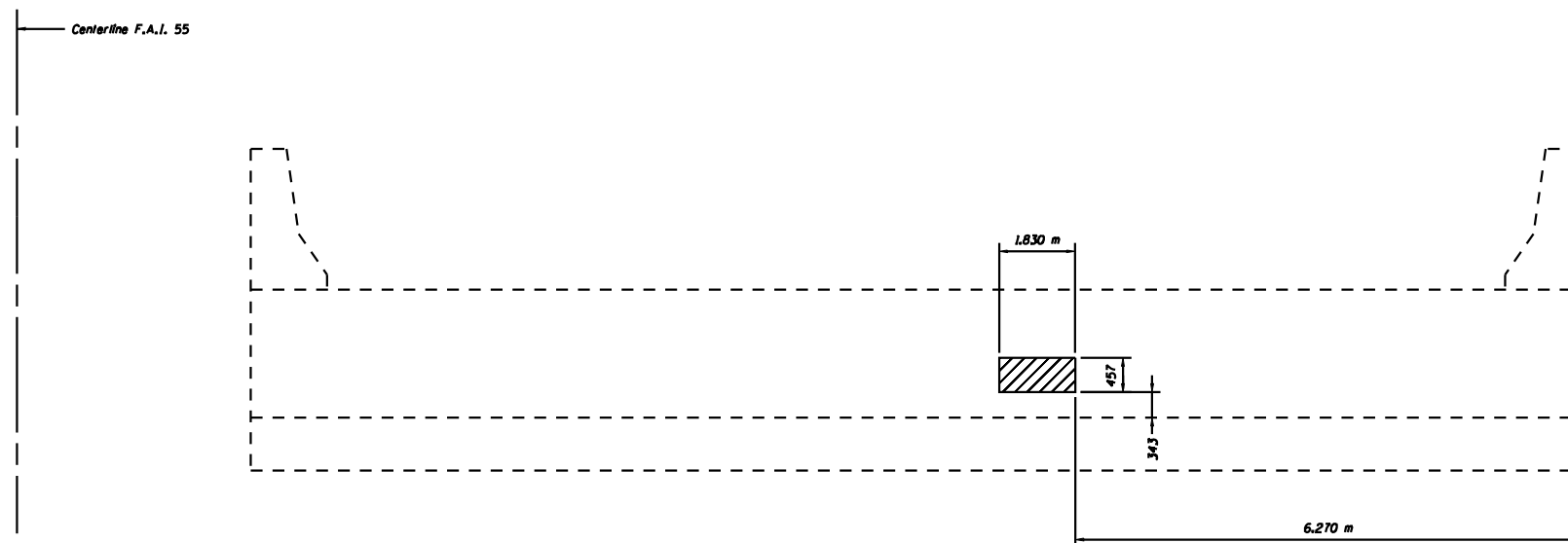

EXISTING EAST ABUTMENT ELEVATION

SN 057-026 (NB)

DESIGNED	GAE
CHECKED	JDA
DRAWN	NO
CHECKED	GAE

**ABUTMENT REPAIR
F.A.I. 55 OVER CONSTITUTION TRAIL
SECTION (57-4)RS-3 & 1
MCLEAN COUNTY
SN 057-0026 (NB)
SN 057-0027 (SB)
STA. 38+263.167**

ROUTE NO.	SECTION	COUNTY	POST MILE	POST MILE	SHEET NO. 12
FAJ 55	*	MCLEAN	87	80	14A SHEETS
FED. ROAD DIST. NO. 7		ILL. PROJ.	FED. AID PROJECT		

* (57-4)RS-3 & 1

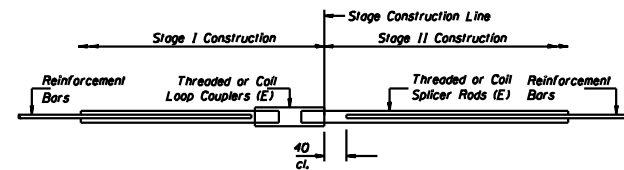

BAR SPLICER ASSEMBLY DETAIL

Bar Size	No. Assemblies Required	Location
#15	170	Slab
#20	16	Backwall

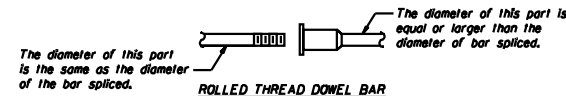

ROLLED THREAD DOWEL BAR



ONE PIECE

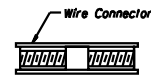

WELDED SECTIONS

BAR SPLICER ASSEMBLY ALTERNATIVES

** Heavy Hex Nuts conforming to ASTM A 563M, Grade C, D or DH may be used.

NOTES

Bar splicer assemblies shall be of an approved type and shall develop in tension at least 125 percent of the yield strength of the lapped reinforcement bars. Splicer rods shall be of minimum 420 MPa yield strength, threaded or colled full length. All reinforcement bars shall be lapped and tied to the splicer rods or dowel bars. Other systems of similar design may be submitted to the Engineer for approval. Approval shall be based on certified test results from an approved testing laboratory that the proposed bar splicer assembly satisfies the following requirements:

① Minimum Capacity = $1.25 \times 10^{-3} \times f_y \times A_s$
(Tension in kN)

② Minimum "Pull-out" Strength = $1.25 \times 10^{-3} \times f_{s,allow} \times A_s$
(Tension in kN)

Where f_y = Yield strength of lapped reinforcement bars in MPa.
 $f_{s,allow}$ = Allowable tensile stress in lapped reinforcement bars in MPa (Service Load)
 A_s = Tensile stress area of lapped reinforcement bars (mm²).
 * = 28 day concrete

Bar Size to be Spliced	Splicer Rod or Dowel Bar Length	Strength Requirements	
		Min. Capacity kN - Tension	Min. Pull-Out Strength kN - Tension
#13	510 mm	68	27
#16	610 mm	102	41
#19	790 mm	147	59
#22	1,04 m	201	80
#25	1,37 m	262	105

Bar splicer assemblies shall be according to Section 508 of the Standard Specifications, except as noted. The furnishing and installation of bar splicer assemblies will be measured and paid for at the contract unit price each for "BAR SPLICERS."
 All dimensions are in millimeters (mm) except as noted.

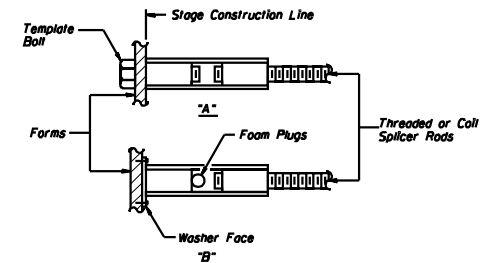

INSTALLATION AND SETTING METHODS

"A" : Set bar splicer assembly by means of a template bolt.
 "B" : Set bar splicer assembly by nailing to wood forms or cementing to steel forms.

DESIGNED	GAE
CHECKED	JDA
DRAWN	NO
CHECKED	GAE

BSD-1 (M) 4-30-97

BAR SPLICER ASSEMBLY DETAILS
F.A.I. 55 OVER CONSTITUTION TRAIL
SECTION (57-4)RS-3 & 1
MCLEAN COUNTY
SN 057-0026 (NB)
SN 057-0027 (SB)
STA. 38+263.167

ROUTE NO.	SECTION	COUNTY	POST MILE	POST MILE	SHEET NO. 13
FAI 55	*	MCLEAN	87	81	14A SHEETS
FED. ROAD DIST. NO. 7		ILL. HIGH.	FED. AID PROJECT		

* (57-4)RS-3 & 1

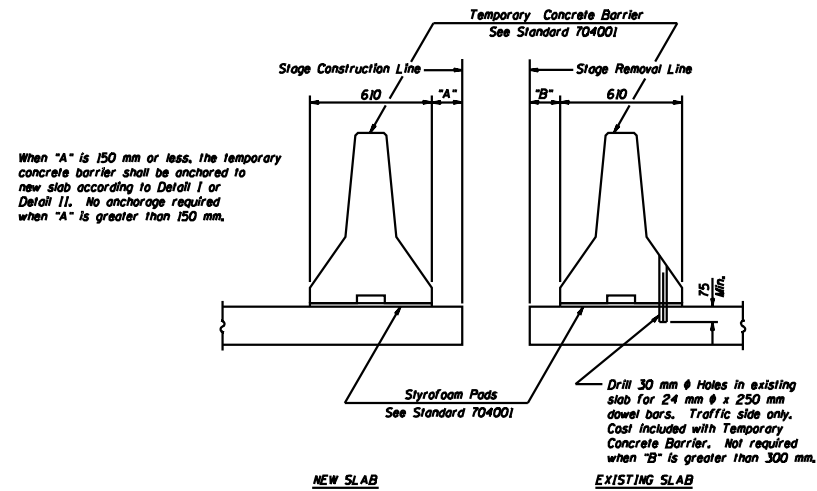

SECTIONS THRU SLAB

NOTES

- Detail I - With Bar Splicer or Couplers:**
Connect one (1) 25x180x250 steel \bar{P} to the top layer of couplers with 2-16 mm ϕ bolts screwed to coupler at approximate \bar{E} of each 3 m barrier panel.
- Detail II - With Extended Reinforcement Bars:**
Connect one (1) 25x180x250 steel \bar{P} to the concrete slab with 2-16 mm ϕ Expansion Anchors or cast in place inserts spaced between the top layer of reinforcement at approximate \bar{E} of each 3 m barrier panel.
- Cost of anchorage included with Temporary Concrete Barrier. All dimensions are in millimeters (mm) except as noted.

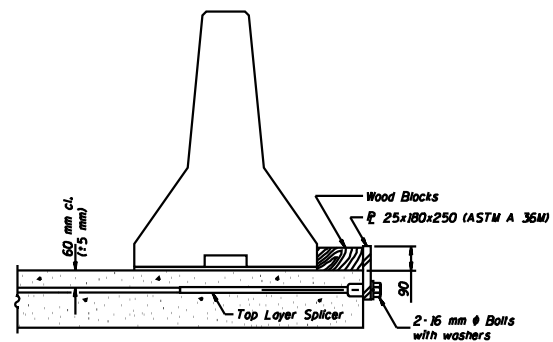

DETAIL I

The 25x180x250 Plate shall not be removed until Stage II Construction forms and reinforcement bars are in place.

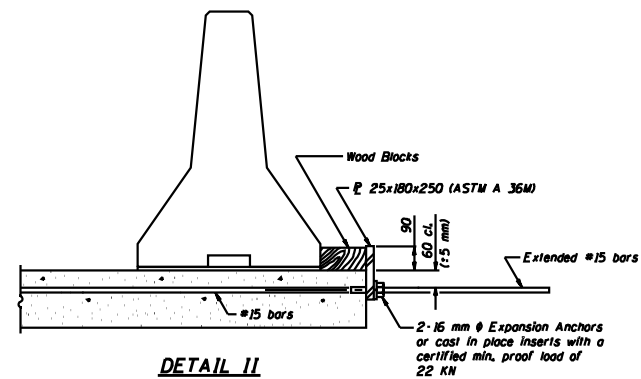

DETAIL II

The 25x180x250 Plate shall not be removed until Stage II Construction forms and all reinforcement bars are in place and the concrete is ready to be placed.

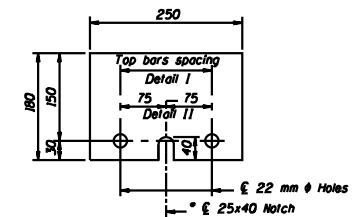

\bar{P} 25x180x250

* Required only with Detail II

DESIGNED	GAE
CHECKED	JDA
DRAWN	NO
CHECKED	GAE

R-27 (M) 4-80-99

TEMPORARY CONCRETE BARRIER
F.A.I. 55 OVER CONSTITUTION TRAIL
SECTION (57-4)RS-3 & 1
MCLEAN COUNTY
SN 057-0026 (NB)
SN 057-0027 (SB)
STA. 38+263.167

ROUTE NO.	SECTION	COUNTY	SHEET NO.	14
FAI 55		McLEAN	87	82
FED. ROAD DIST. NO. 7		ILL. HIGHWAY PROJECT NO.		

• (57-4)RS-3 & 1

The Illinois Coil-Lock Anchor Bolt is a proprietary item which is the property of the Illinois Department of Transportation. Use, reproduction or disclosure without express written permission is prohibited and protected under Federal copyright laws. The production and the fabrication of this bolt for use on highway projects in the State of Illinois shall be permitted and there shall be no incurred charges or fees to the manufacturer or the fabricator for producing or fabricating this bolt.

D	E	H	K	"d"
24	27	20	44	6
30	33	26	51	10
36	39	32	54	13
48	51	44	73	15
64	67	60	86	25

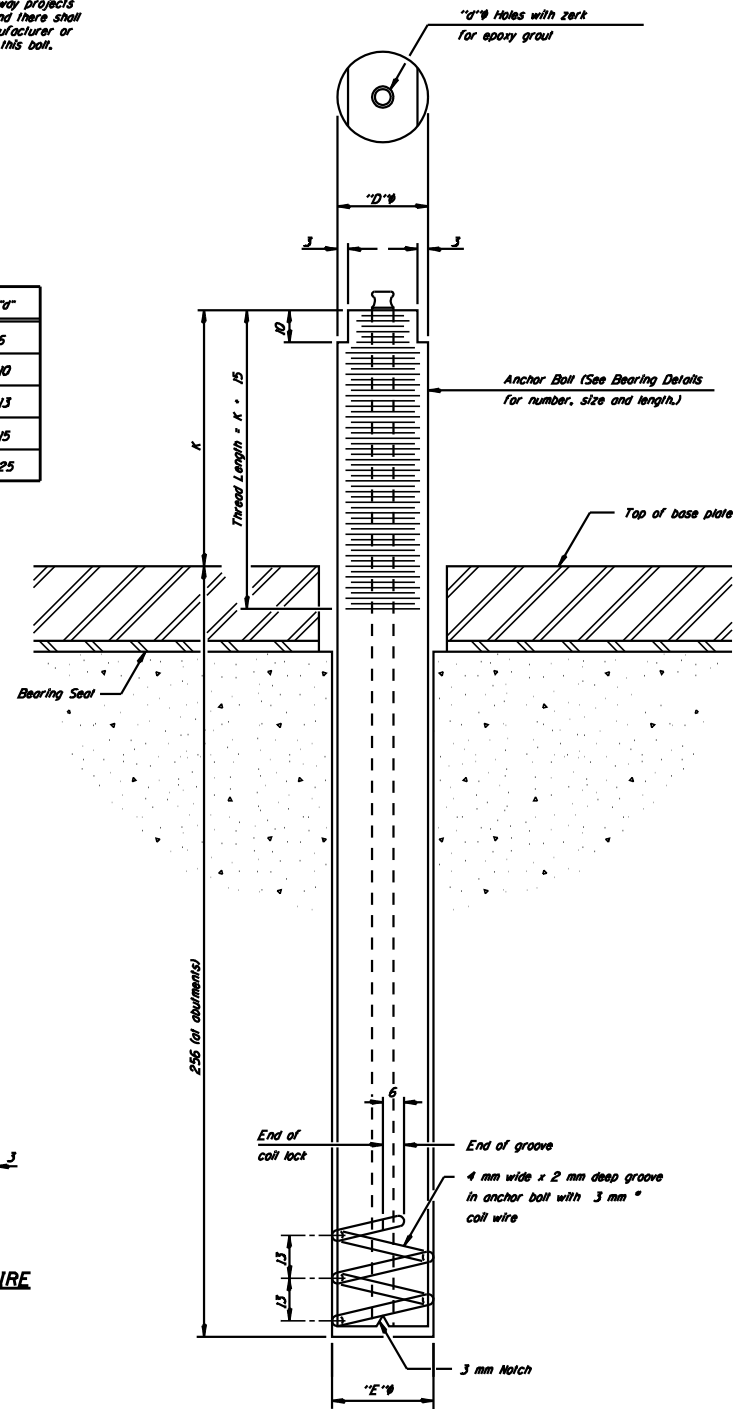

ILLINOIS COIL-LOCK ANCHOR BOLT

DESIGNED	GAE
CHECKED	JDA
DRAWN	NO
CHECKED	GAE

ABB-1 4-80-99

MATERIALS FOR ILLINOIS COIL-LOCK

ANCHOR BOLT

The anchor bolt shall be fabricated from cold drawn or hot finished seamless carbon steel mechanical tubing conforming to ASTM A 513, Grade 1026, CW and supplied with hexagonal nuts and coil washers.
 The coil wire shall be made of any suitable soft steel wire.
 The finished anchor bolt shall be cleaned of rust and other foreign materials and wrapped or packaged to prevent contamination until they are installed.
 The epoxy grout shall be a two-component, epoxy resin bonding system conforming to ASTM C 881, Type I, Grade 1 and of a Class suitable for the temperature of installation.

INSTALLATION PROCEDURE for the ILLINOIS

COIL-LOCK ANCHOR BOLT

1. With the coil wire in place, the bolt shall be inserted into the hole and turned clockwise to a snug fit in the hole. Nut and washer shall be placed on the bolt. The nut shall be tensioned until the steel base plates are held securely to the concrete bearing seat.
2. Epoxy grout shall be pumped through the zerk fitting with a pressure gun. Pumping shall continue until the epoxy overflows the hole around the bolt shank. After pumping is discontinued, excess epoxy shall be immediately wiped off.

ALTERNATE ANCHOR BOLTS

The Contractor may use, at his option, the capsule or the adhesive cartridge type anchor rods that have been previously tested and given a prior approval by the Department. The Contractor shall install these anchor rods in pre-drilled holes according to the manufacturer's recommendations and procedures.
 The capsule or the adhesive cartridge type anchor rods shall be a two part system composed of:
 1. A threaded rod stud with nut and washer of the type specified.
 2. A sealed glass capsule or a sealed glass adhesive cartridge containing premeasured amounts of the adhesive chemical.

ASTM F 1554 (Fy = 724 mpa), ASTM A 449 and AASHTO M 314 (Fy = 724 mpa) anchor bolts may be substituted for the anchor bolts shown above.

Location	Type
Abutts.	A307

GENERAL NOTES

Holes in the masonry for anchor bolts shall be drilled through the base plates to the diameter and depth shown or according to the manufacturer's recommendation after beams or girders have been erected and adjusted.
 Prior to setting the bolts, the holes shall be dry and all dust and loose particles shall be removed by the use of compressed air or vacuuming.
 The anchor bolts, furnished and installed and including the epoxy grout or capsules shall not be paid for separately but shall be included in the unit bid price for Furnishing and Erecting Structural Steel.
 All dimensions are in millimeters (mm) except as noted.

**ANCHOR BOLT DETAILS FOR BEARINGS
 F.A.I. 55 OVER CONSTITUTION TRAIL
 SECTION (57-4)RS-3 & 1
 McLEAN COUNTY
 SN 057-0026 (NB)
 SN 057-0027 (SB)
 STA. 38+263.167**

ROUTE NO.	SECTION	COUNTY	POST MILE	POST MILE	SHEET NO. 14A
FAJ 55		MCLEAN	87	82A	14A SHEETS
FED. ROAD DIST. NO. 7		ILL. PROJ.	FED. AID PROJECT		

* Granular or solid flux filled headed studs conforming to Article 1006.32 of the Std. Specs., automatically end welded.

** When joint is fixed, dimension is set at 40mm.

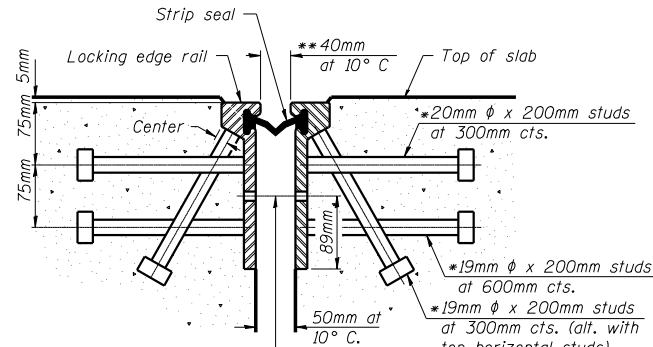

12mm ϕ holes at 1.22m cts. for 10mm ϕ bolts. All bolts shall be burned, sawed, or chipped off flush with the plates after forms are removed, typ.

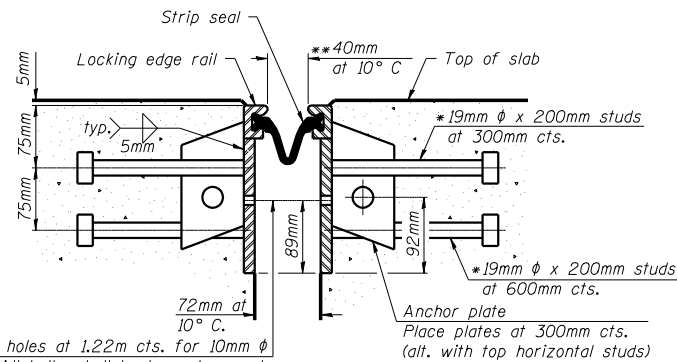

12mm ϕ holes at 1.22m cts. for 10mm ϕ bolts. All bolts shall be burned, sawed, or chipped off flush with the plates after forms are removed, typ.

Notes:

The strip seal shall be made continuous and shall have a minimum thickness of 5mm. The configuration of the strip seal shall match the configuration of the Locking Edge Rails. Open or "webbed" strip seal gland configurations are not permitted. The gland shall be sized for a maximum rated movement of 4 inches.

The height and thickness of the Locking Edge Rails shown are minimum dimensions. The actual configuration of the Locking Edge Rails and matching strip seal may vary from manufacturer to manufacturer. Flanged edge rails will not be allowed. Locking Edge Rails may be spliced at slope discontinuities and stage construction joints.

The manufacturer's recommended installation methods shall be followed. The joint opening and deck dimensions detailed on the superstructure are based on a rolled rail expansion joint. If the Contractor elects to use the welded rail expansion joint, the opening and deck dimensions shall be modified according to the dimensions detailed on this sheet. Required modifications shall be made at no additional cost to the State.

All steel components shall be galvanized after fabrication according to Article 520.03 of the Standard Specifications.

All dimensions are in millimeters (mm) except as noted.

SECTION THRU ROLLED RAIL JOINT

SECTION THRU WELDED RAIL JOINT

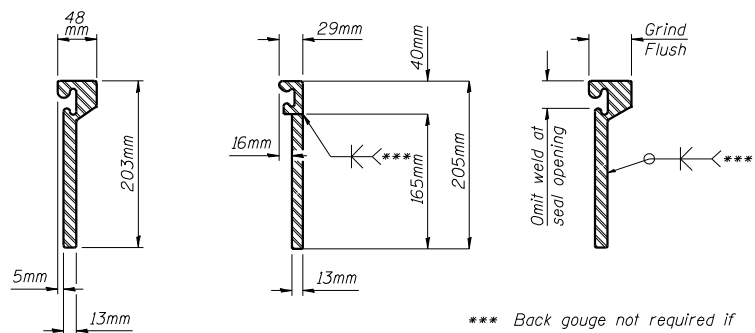

ROLLED (EXTRUDED) RAIL **WELDED RAIL**

LOCKING EDGE RAIL SPLICE

The inside of the locking edge rail groove shall be free of weld residue.

ANCHOR PLATE (for welded rail)

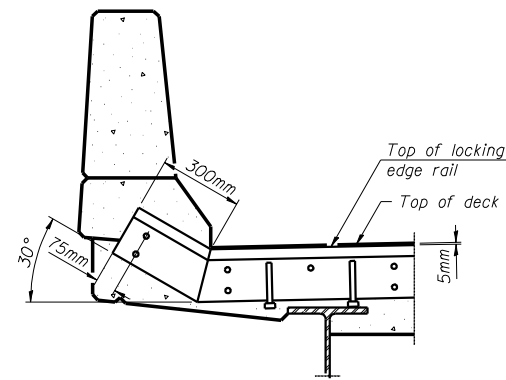

AT PARAPET

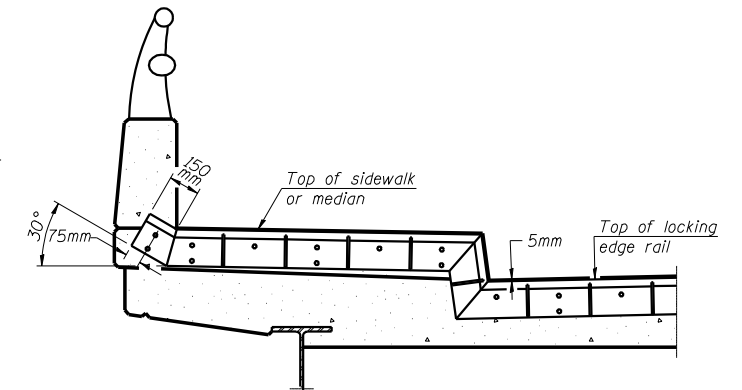

AT SIDEWALK OR MEDIAN

Shorter plates with a single row of studs at 300mm cts. may be necessary on medians which are shallower than 230mm. See manufacturer's recommendation.

TYPICAL END TREATMENTS

LOCKING EDGE RAILS

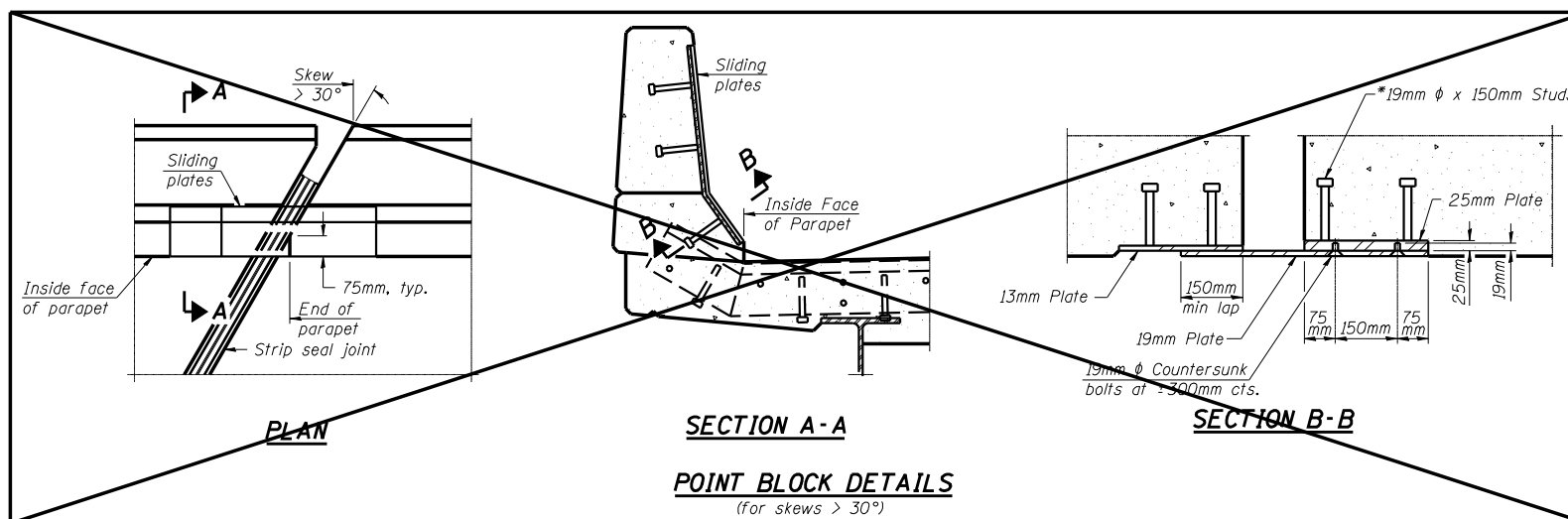

SECTION A-A
POINT BLOCK DETAILS
(for skews > 30°)

BILL OF MATERIAL

Item	Unit	Total
Preformed Joint Strip Seal	Meter	87.3

DESIGNED	JDA
CHECKED	JKC
DRAWN	NO
CHECKED	JDA

200	EXAMINED
	PASSED
	ENGINEER OF BRIDGE DESIGN
	ENGINEER OF BRIDGES AND STRUCTURES

EJ-SSJ

11-1-06

PREFORMED JOINT STRIP SEAL
F.A.I. 55 OVER CONSTITUTION TRAIL
SECTION (57-4)RS-3 & 1
MCLEAN COUNTY
SN 057-0026 (NB)
SN 057-0027 (SB)
STA. 38+263.167

ROUTE NO.	SECTION	COUNTY	SHEET	TOTAL SHEETS
FAI 55	#	McLEAN	87	83
SHEET NO. 1				
5 SHEETS				
* (57-4)RS-3 & 1				

Benchmark: #23 nail in 915 mm cottonwood tree 15.850 m Lt. Sta. 38+561.887 Elev. 266.591

Existing Structures

Structure Number 057-0028 (NB) and 057-0029 (SB) are dual structures carrying FAI Route 55 over Linden Street. Section 57-4HB-3, McLean County at Station 38+543.992. Structures were built in 1962 as a continuous slab deck supported by 2 multiple column piers and pile bent abutments. Structures are 13.310 m out-to-out and 34.950 m long. In 1974 the expansion joints were replaced and the deck was waterproofed and resurfaced with 38 mm surface course. In 1992 the outside curbs were retrofitted with new steel railing, deck drains, neoprene expansion joints, and various bearings were replaced. Longitudinal deck joints were eliminated, the waterproofing and surfacing was replaced, and concrete repairs were performed on the substructure.

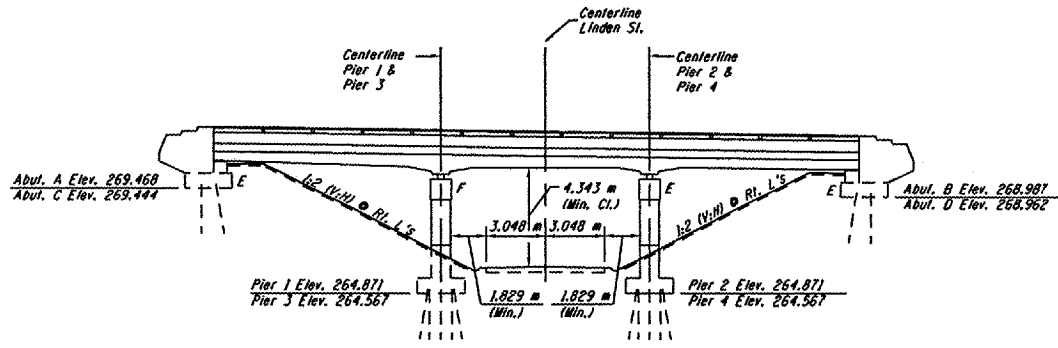

ELEVATION

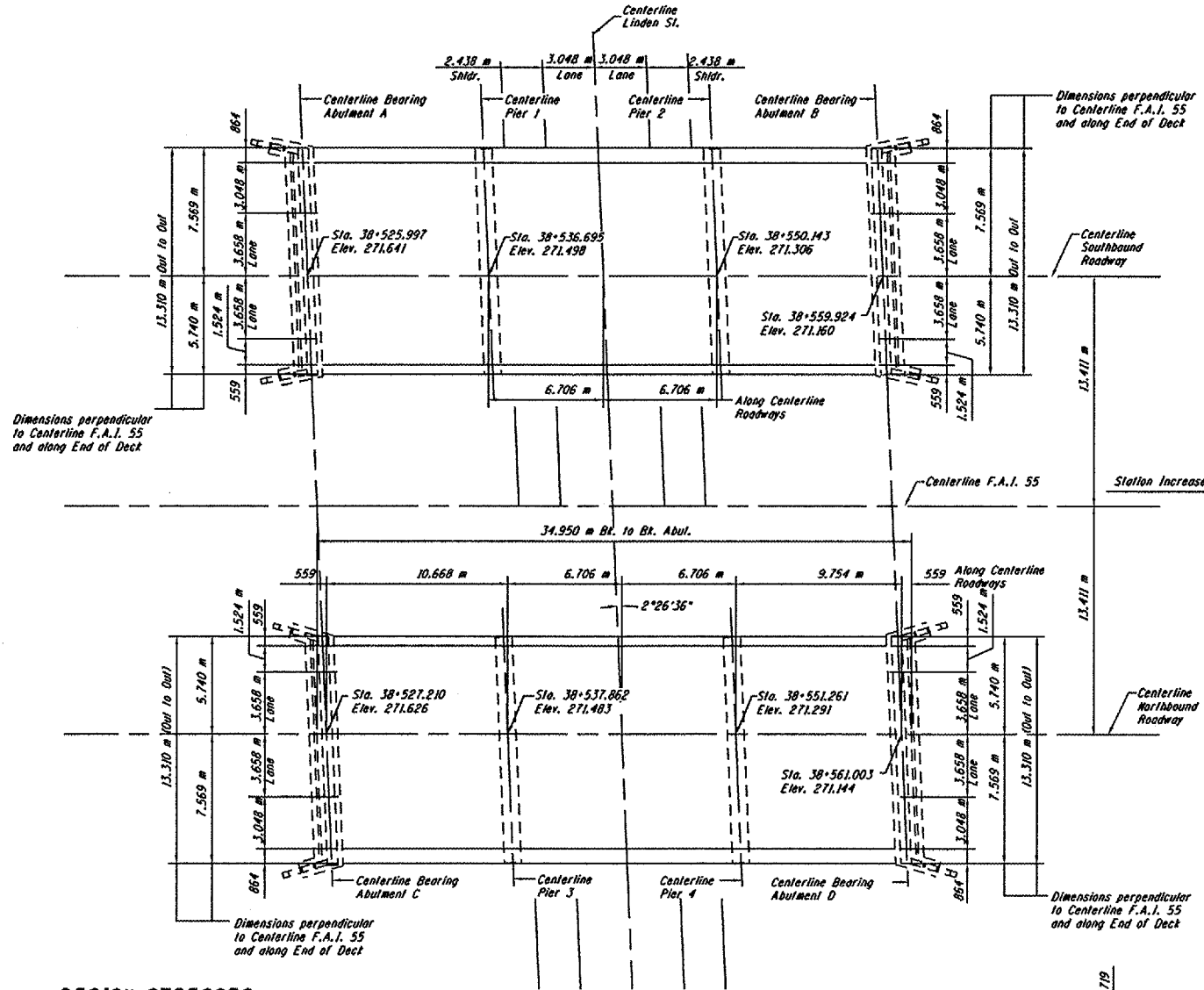

PLAN

Proposed Work

1. Replace all four abutment PJS Expansion Joints with Silicone Joint Sealer.
2. Deck patching and remove and replace bituminous overlay and waterproofing membrane.
3. Plug deck drains near abutments and piers.
4. Structural repair of concrete of north curb of bridge deck and patch west slope wall of SN 057-0029 (SB).
5. Riprap along southwest and northeast slope soil of SN 057-0028 (NB).

Traffic to be maintained by staged construction.

TOTAL BILL OF MATERIALS				
Item	Unit	Super	Sub.	Total
STONE RIPRAP, CLASS A3	SD M	--	6	6
HOT-MIX ASPHALT SURFACE REMOVAL (DECK)	SD M	814.4	--	814.4
SLOPE WALL REMOVAL	SD M	--	0.4	0.4
SLOPE WALL 100 mm	SD M	--	0.4	0.4
STRUCTURAL REPAIR OF CONCRETE (DEPTH EQUAL TO OR LESS THAN 125 MM)	SD M	0.4	--	0.4
WATERPROOFING MEMBRANE SYSTEM	SD M	814.4	--	814.4
SILICONE JOINT SEALER	METER	53.3	--	53.3
PLUG EXISTING DECK DRAINS	EACH	16	--	16
DECK SLAB REPAIR (PARTIAL)	SD M	95.7	--	95.7
POLYMERIZED HOT-MIX ASPHALT SURFACE COURSE, MIX E, M90	WTM	74.2	--	74.2

General Notes

Plan dimensions and details relative to existing plans are subject to routine variations. The Contractor shall field verify existing dimensions and details affecting new construction and make necessary approved adjustments prior to construction or ordering of materials. Such variations shall not be cause for additional compensation for a change in scope of the work, however, the Contractor will be paid for the quantity actually furnished based upon the unit price bid for the work.

All dimensions are in millimeters (mm) except as noted.

CURVE
 PT STA. = 38+663.038
 $\Delta = 3^\circ 00' 00''$
 $D = 0^\circ 15'$
 $R = 6985.515$ m
 $T = 182.922$ m
 $L = 365.761$ m
 $E = 2.394$ m
 $S.E. = \text{None}$
 PC STA. = 38+480.199
 PT STA. = 38+845.960

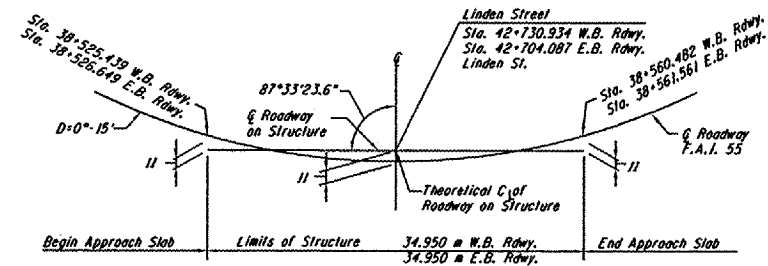

DETAIL-STRUCTURE LOCATION ON F.A.I. 55
NO SCALE

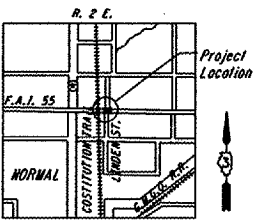
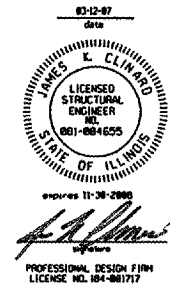

LOCATION SKETCH

DESIGN STRESSES (EXISTING CONSTRUCTION)	
DESIGNED	JDA
CHECKED	JKC
DRAWN	NQ
CHECKED	JDA

Concrete: $f'_c = 24.1$ Mpa
 Reinforcement: $f_s = 138$ Mpa
 Structural Steel: $f_s = 124$ Mpa
 Design Loading: MS18 & Alternate
 Design Specifications: AASHTO 1957

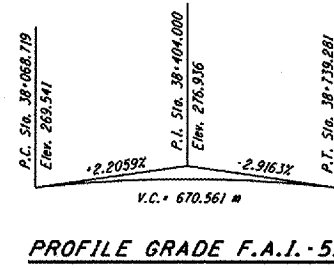

PROFILE GRADE F.A.I. 55

GENERAL PLAN AND ELEVATION F.A.I. 55 OVER LINDEN STREET SECTION (57-4)RS-3 & 1
 McLEAN COUNTY
 SN 057-0028 (NB)
 SN 057-0029 (SB)
 STA. 38+543.992

CHAMLIN ASSOCIATES
 PERU ILLINOIS MORRIS

ROUTE NO.	SECTION	COUNTY	DATE	SHEET NO.
FAI 55		MCLEAN	07 04	2
FED. ROAD DIST. NO. 7		ILL. PROJ.	FED. AID PROJECT	5 SHEETS

• (57-4)RS-3 & 1

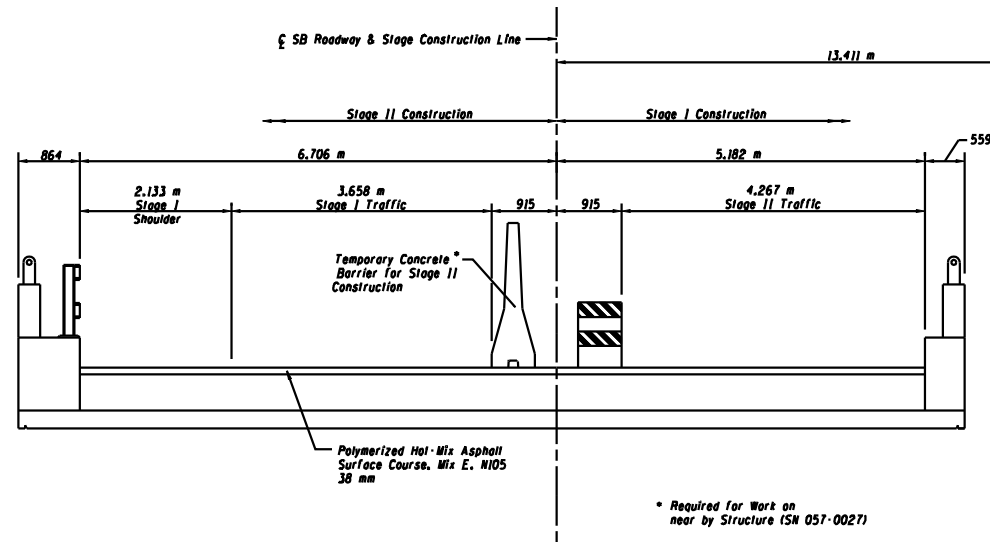

SOUTHBOUND
S.N. 057-0029 (SB)

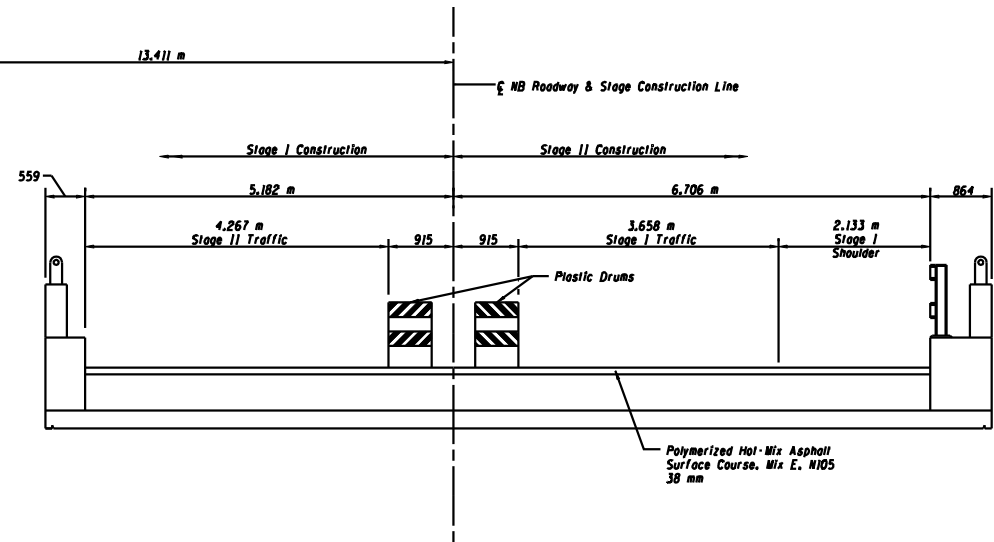

NORTHBOUND
S.N. 057-0028 (NB)

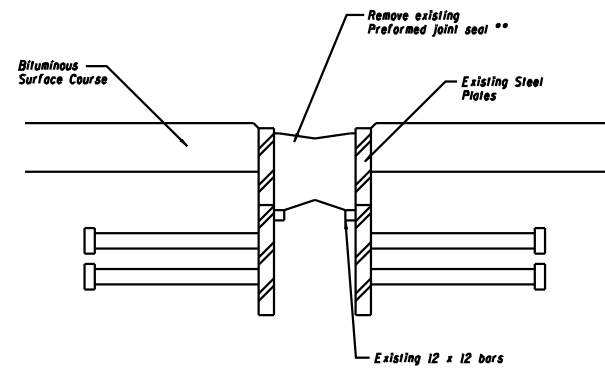

EXISTING
PREFORMED JOINT SEAL

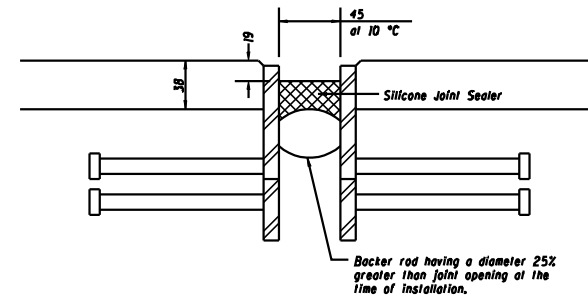

PROPOSED
SILICONE JOINT SEALER DETAIL

DESIGNED	JDA
CHECKED	JKC
DRAWN	NO
CHECKED	JDA

**STAGE CONSTRUCTION CROSS SECTIONS AND
EXPANSION JOINT REPLACEMENT DETAILS
F.A.I. 55 OVER LINDEN STREET
SECTION (57-4)RS-3 & 1
MCLEAN COUNTY
SN 057-0028 (NB)
SN 057-0029 (SB)
STA. 38+543.992**

ROUTE NO.	SECTION	COUNTY	SHEET	SHEET NO.
FAI 55	#	McLEAN	87	85
FED. ROAD DIST. NO. 7	HALF MILES	FED. AID PROJECT		

• (57-4)RS-3 & 1

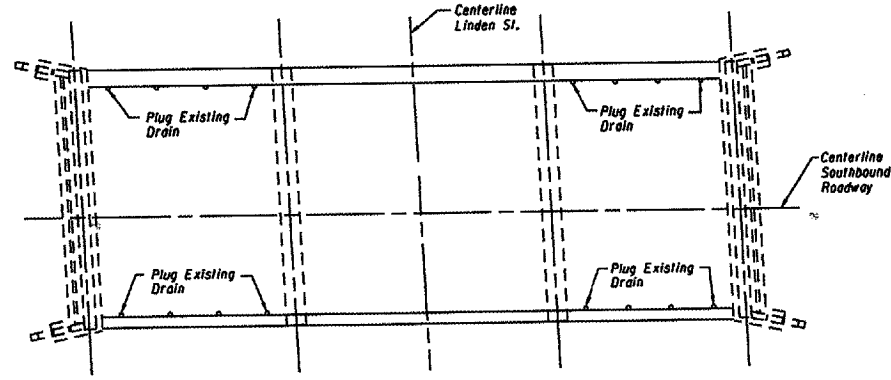

DECK DRAIN PLAN
SN 057-0029 (SB)
(SN 057-0028 (NB) Similar)

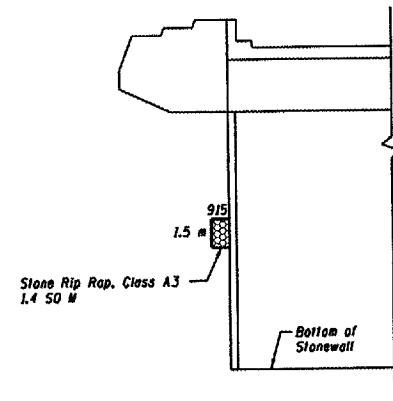

WEST SLOPEWALL, SOUTH END
SN 057-0028 (NB)

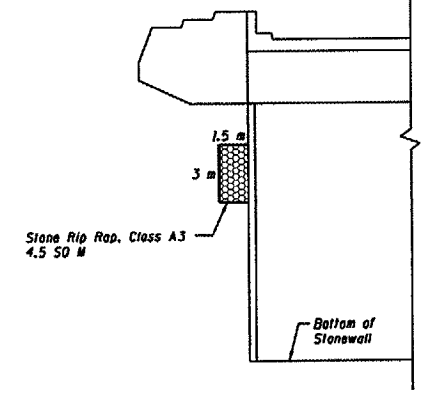

EAST SLOPEWALL, NORTH END
SN 057-0028 (NB)

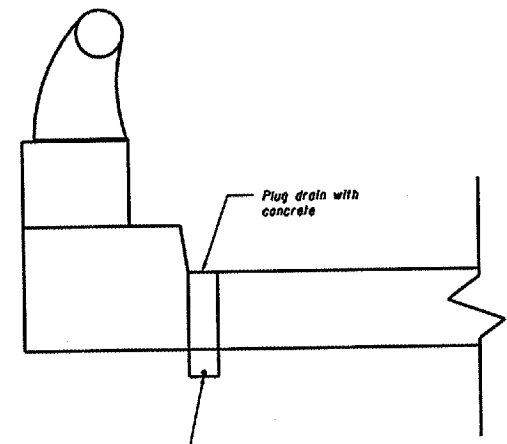

Field Drill 10 mm ϕ hole for 6 mm ϕ Threaded rod 330 mm long with nuts and washers. Cost of threaded rod, nuts, washers, concrete and labor shall be considered included in the cost for "Plug Deck Drain".

DETAIL FOR DRAINS TO BE PLUGGED

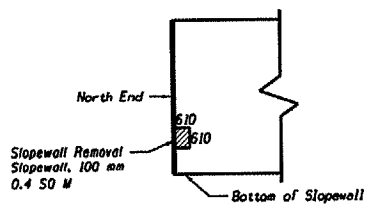

EAST SLOPEWALL
(Looking East)
SN 057-0029 (SB)
Welded Wire Fabric 152 x 152 - MW25.8 x MW25.8 with a mass of 2.51 kg/m². A length of 150mm of existing welded wire around the removal area shall be exposed in order to lap with the proposed welded wire fabric.

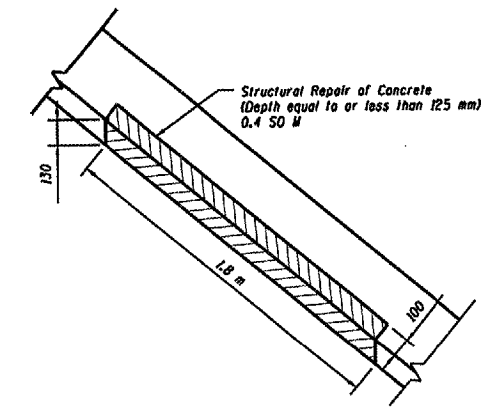

NORTH CURB OF BRIDGE DECK
SN 057-0029

DESIGNED	JDA
CHECKED	JKC
DRAWN	NQ
CHECKED	JDA

MISCELLANEOUS REPAIR DETAILS
F.A.I. 55 OVER LINDEN STREET
SECTION (57-4)RS-3 & 1
McLEAN COUNTY
SN 057-0028 (NB)
SN 057-0029 (SB)
STA. 38+543.992

ROUTE NO.	SECTION	COUNTY	DATE	SHEET NO.
FAI 55		MCLEAN	07 06	4
FED. ROAD DIST. NO. 7		ILL. HIGH.	FED. AID PROJECT	5 SHEETS

• (57-4)RS-3 & 1

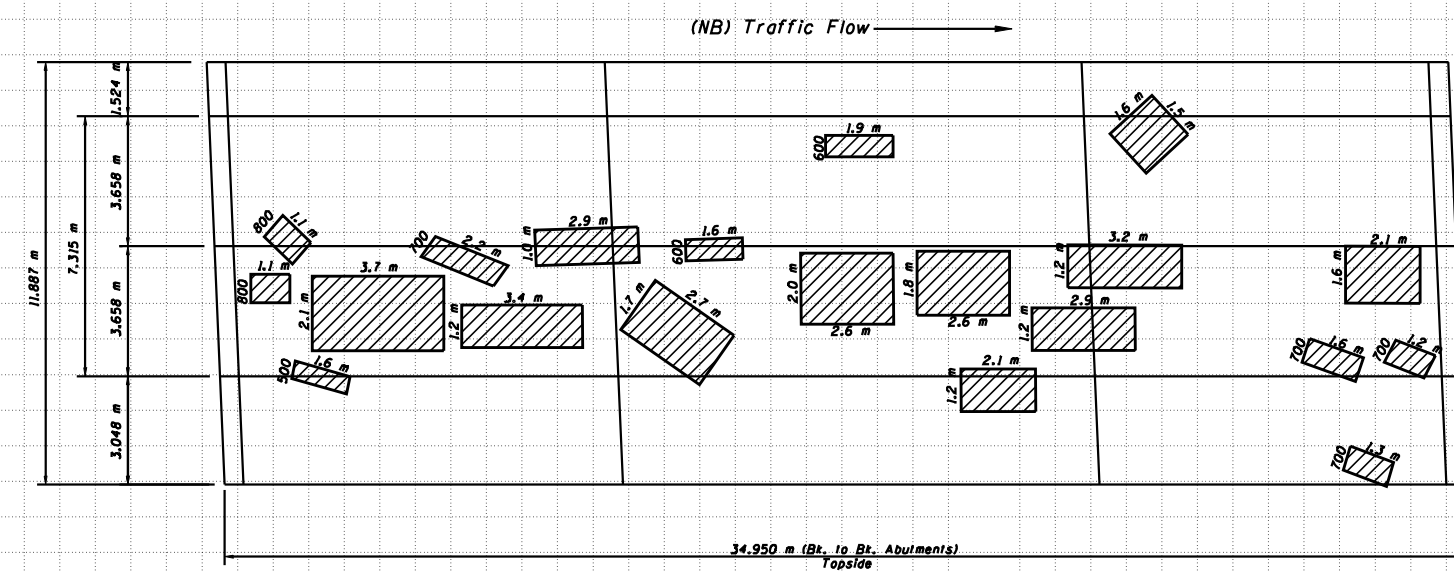
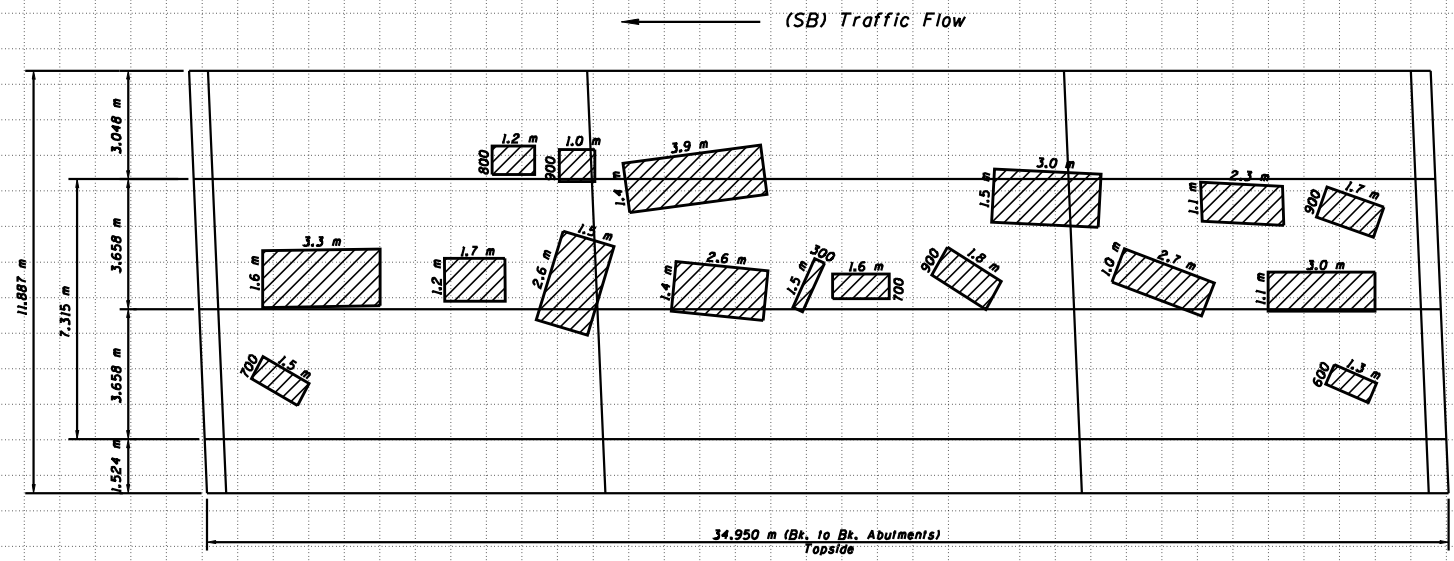

 Deck Slab Repair
(Partial)
41.8 SQ M (SB)
53.9 SQ M (NB)

DESIGNED	JDA
CHECKED	JKC
DRAWN	NO
CHECKED	JDA

DECK REPAIRS
F.A.I. 55 OVER LINDEN STREET
SECTION (57-4)RS-3 & 1
MCLEAN COUNTY
SN 057-0028 (NB)
SN 057-0029 (SB)
STA. 38+543.992

ROUTE NO.	SECTION	COUNTY	DATE	SHEET NO.
FAI 55		MCLEAN	07	5
FED. ROAD DIST. NO. 7		ILL. HIGH.	FED. AID PROJECT	5 SHEETS

• (57-4)RS-3 & 1

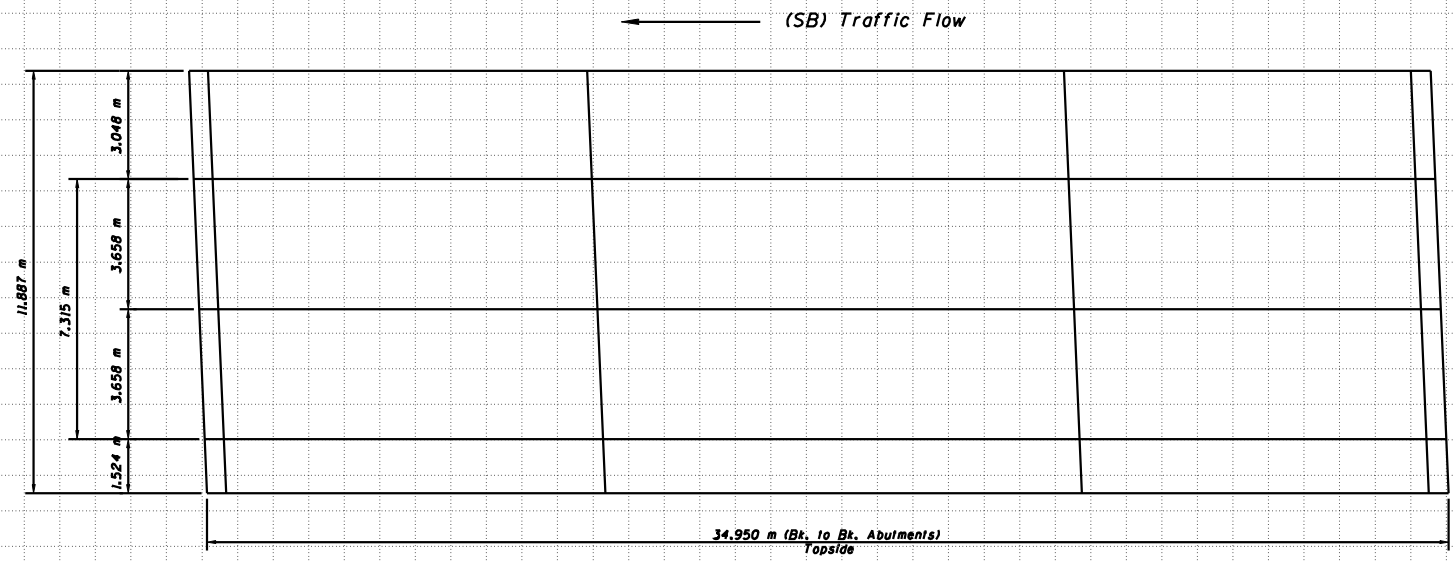

DESIGNED	JDA
CHECKED	JKC
DRAWN	NO
CHECKED	JDA

AS BUILT
DECK REPAIRS
F.A.I. 55 OVER LINDEN STREET
SECTION (57-4)RS-3 & 1
MCLEAN COUNTY
SN 057-0028 (NB)
SN 057-0029 (SB)
STA. 38+543.992