

A (Roadway Width)	B (Finger Pl. Length)	C	L (Finger Pl. Length)	N (Finger Pl. Width)	W (Finger Pl. Width)
24'-11"	24'-10 1/2"	3 1/4"	7"	73	2'-5"

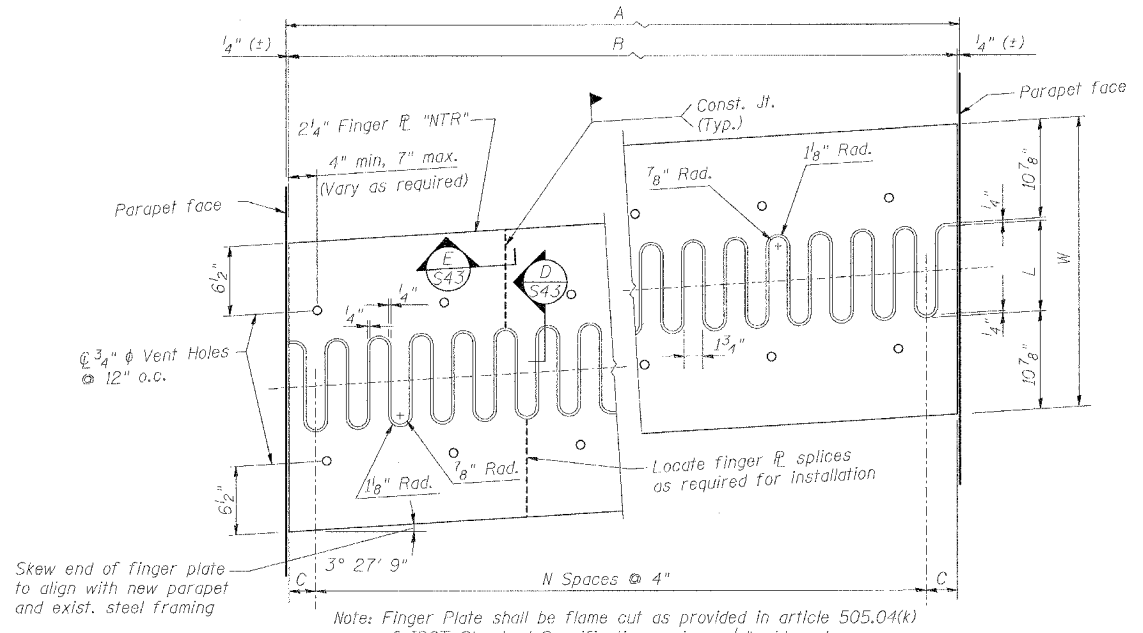

BILL OF MATERIAL

Bar	No.	Size	Length	Shape	
a ₃₀₀ (E)	12	#5	27'-10"	—	
b ₃₀₀ (E)	50	#4	6'-5"	C	
Reinforcing Bars, Epoxy Coated				Pound	560
Fabric Reinforced Elastomeric Trough				Foot	29
Concrete Removal				Cu. Yd.	6.0
Concrete Superstructure				Cu. Yd.	6.0
Finger Plate Expansion Joint, 3"				Foot	25

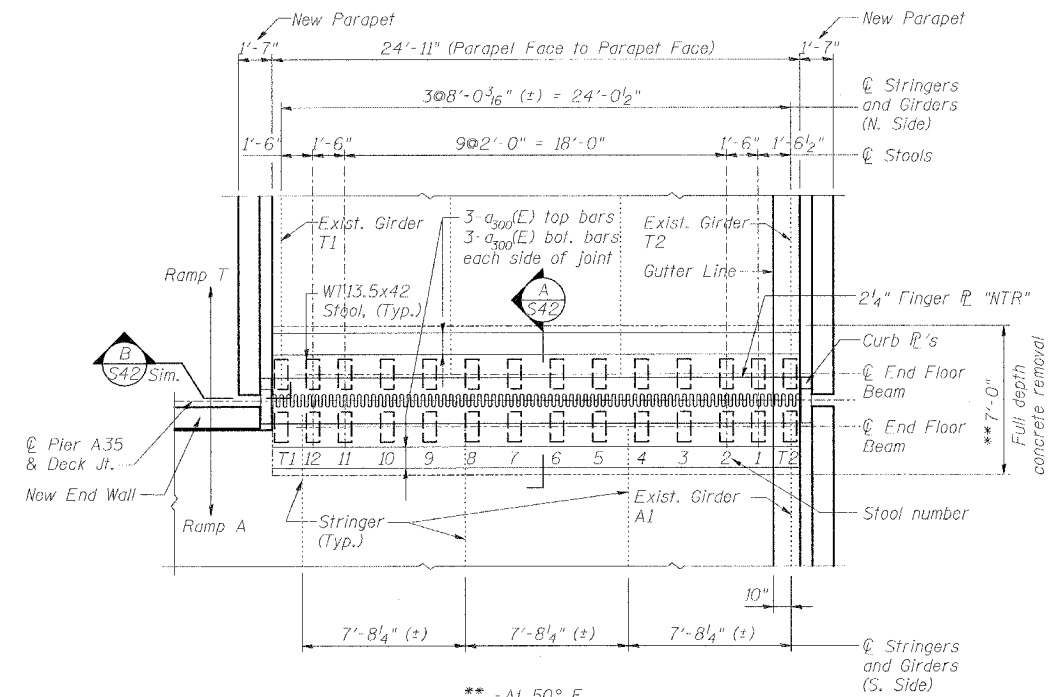
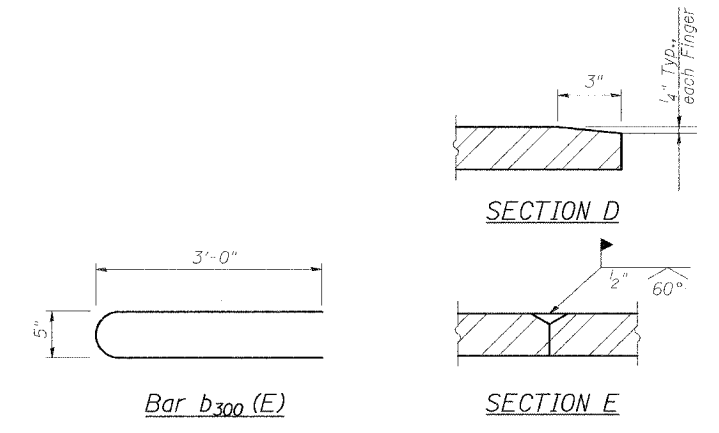

Notes:
All steel for finger plate joint shall be M270 Grade 50. Curb plates and parapet not shown for clarity. Slope trough 1"/ft towards GIRDER T2. Details of trough per Sht. S47. Adjust height of stool as required by shimming. Shims to be 1/8", 1/4", or 1/2" as required. Standard shim pack to include 1/2", 1/4", 1/8" and (2) 1/16" shims. Load carrying components designated "NTR" shall conform to the Supplemental Requirements for Notch Toughness, Zone 2.

FINGER PLATE CUTTING DETAIL

	a			b		
	-30°F	50°F	130°F	-30°F	50°F	130°F
	5 1/2"	3 3/8"	3 1/4"	1 1/2"	3 7/8"	6 1/4"

Note: For deck temperatures between those shown, interpolate between dimensions given above.

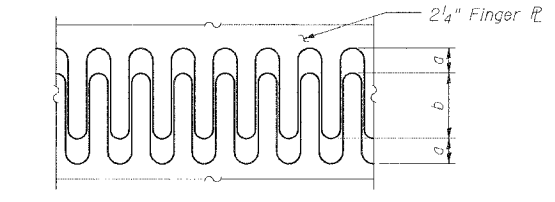

FINGER PLATE SETTING DIAGRAM

Min Bar Laps	d			f		
#4	-30°F	50°F	130°F	-30°F	50°F	130°F
1'-8"	13 1/4"	10 7/8"	8 1/2"	7 3/8"	5"	2 5/8"

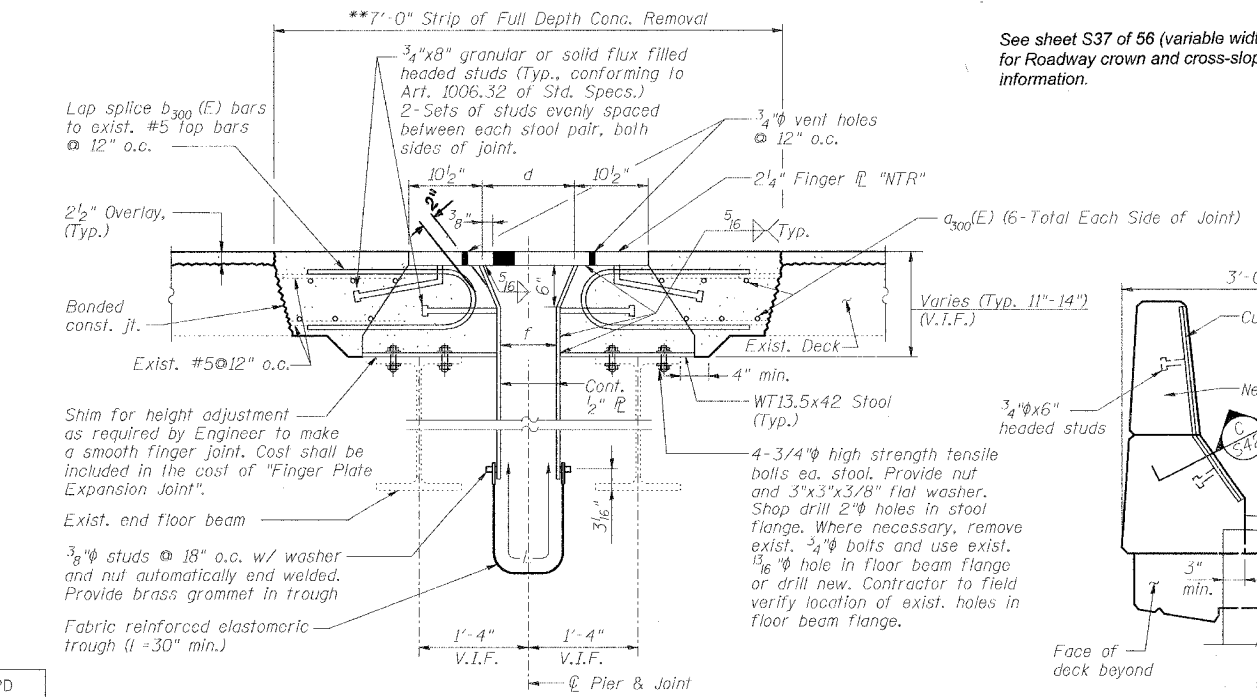

SECTION A

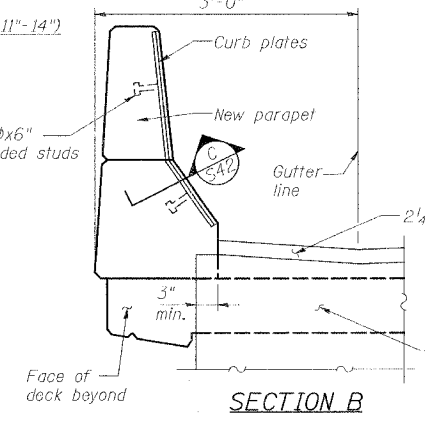

SECTION B

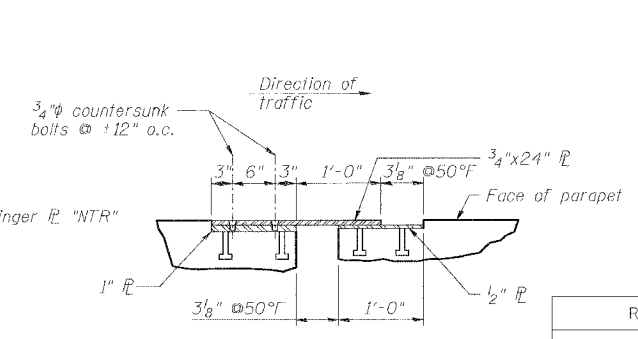

SECTION C

THEORETICAL STOOL HEIGHTS*

Stool No.	Span T1	Span A35
1	9 1/4"	8 3/8"
2	9 1/4"	8 5/8"
3	9 1/4"	9"
4	9 1/4"	9 3/8"
5	9 1/4"	9 7/8"
6	9 1/4"	10 1/4"
7	9 1/4"	10 5/8"
8	9 1/4"	9 3/4"
9	9 1/4"	10 8"
10	9 1/4"	10 1/2"
11	9 1/4"	10 7/8"
12	9 1/4"	11 1/4"
T1	8 5/8"	11 1/2"
T2	10 1/4"	10 3/8"

*Must be field verified prior to fabrication.

SPECIAL JOINT DETAILS

STATE OF ILLINOIS
DEPARTMENT OF TRANSPORTATION
REHABILITATION AND RETROFIT REPAIRS
FAI ROUTE 70
POPLAR STREET BRIDGE APPROACHES
ST. CLAIR COUNTY

STRUCTURE NO. 082-0141 (ROADWAY A)
SCALE: N.T.S.
DATE: 02/01/2007

REVISIONS	
NAME	DATE

DATE: 1/29/2007 FILENAME: p:\2001\1201-1800\2001.1240\Drafting\RoadwayRehab_A1\RampA\join_A-JOIN03.dgn

DESIGNED	JPD
CHECKED	CSD
DRAWN	CLK
CHECKED	JPD