

TAB. NO.	SECTION	COUNTY	TOTAL SHEETS	SHEET NO.
3385	96-00306-00-5P	McLean	30	27

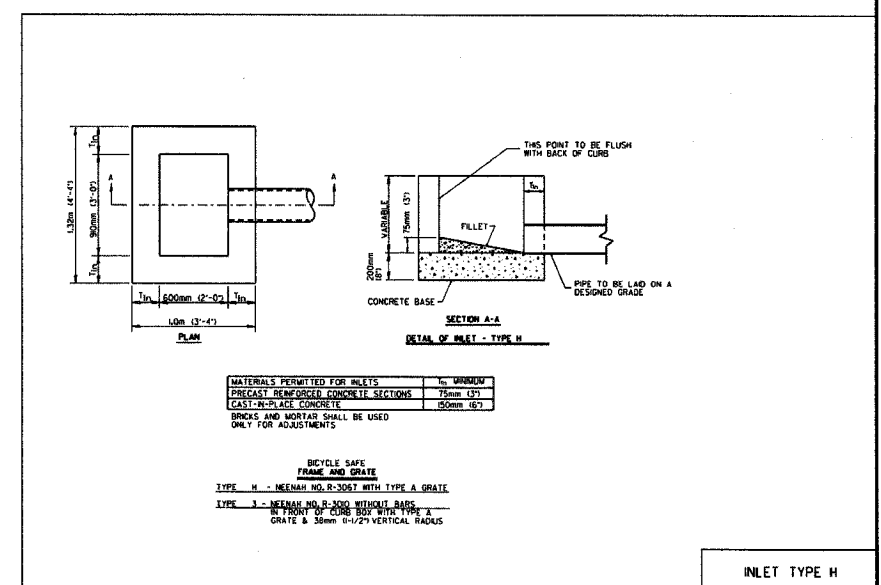
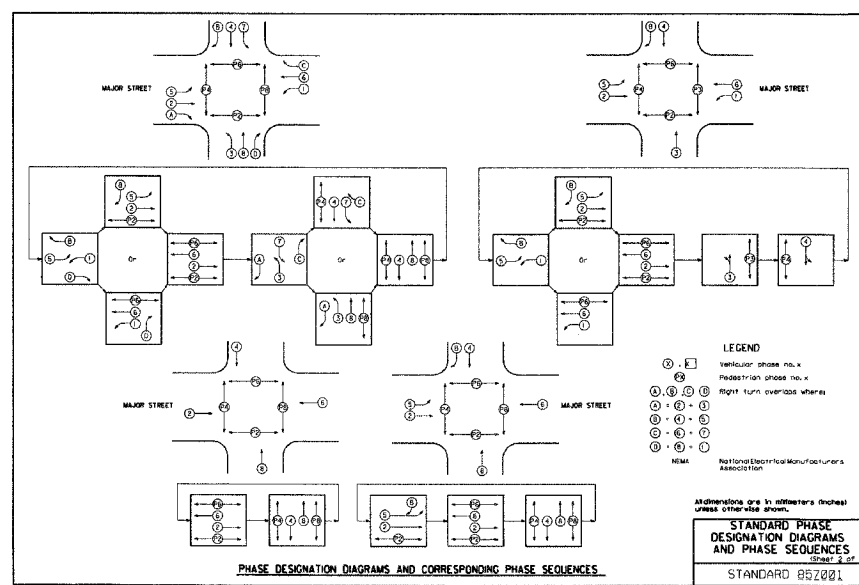
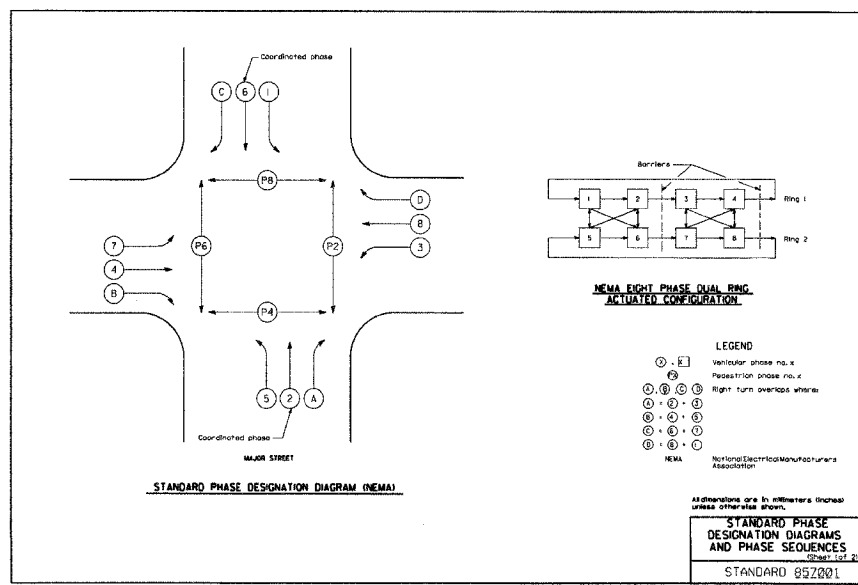
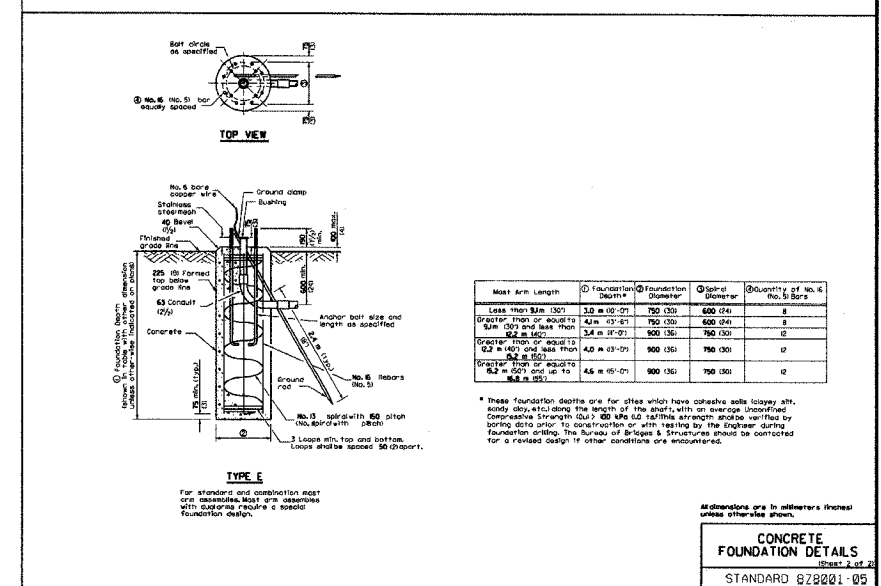
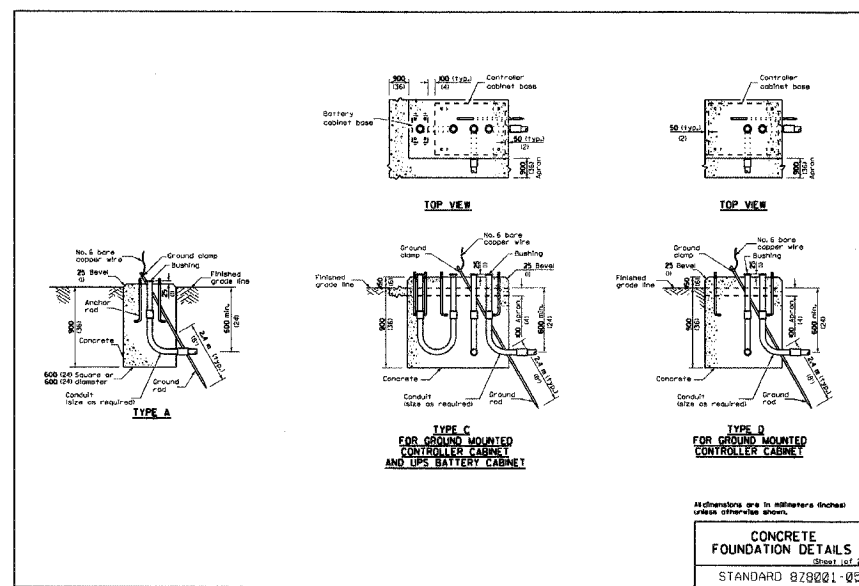
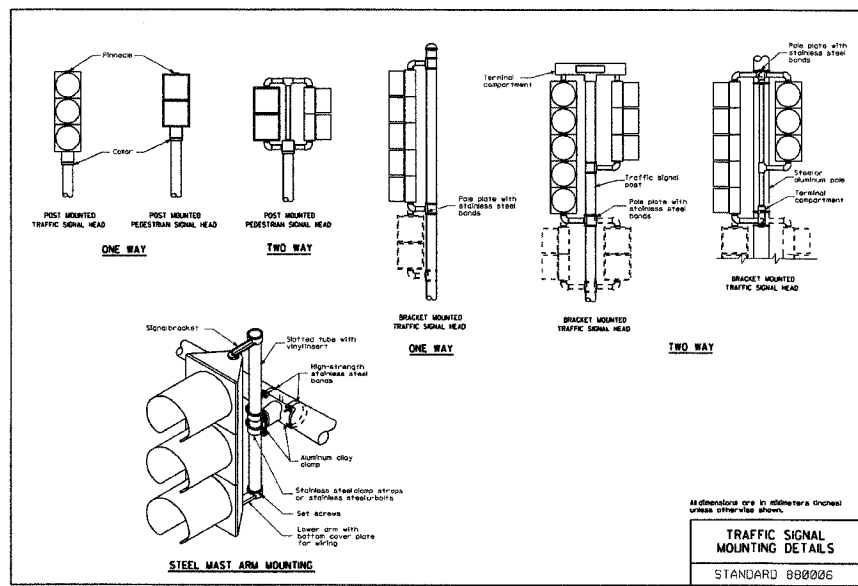
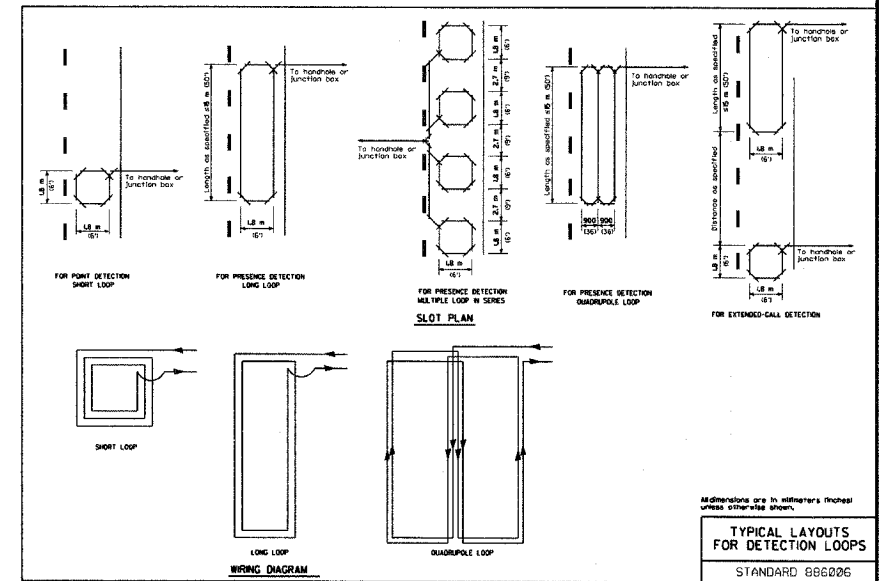
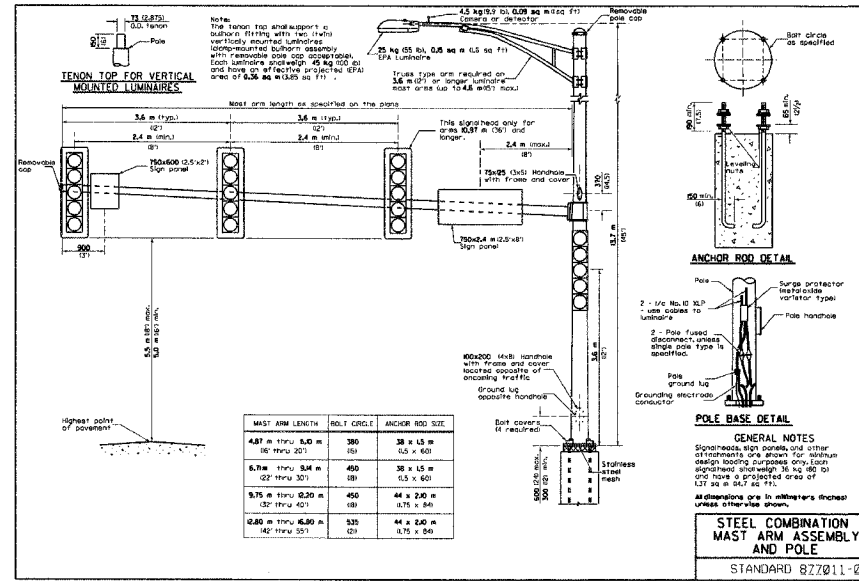
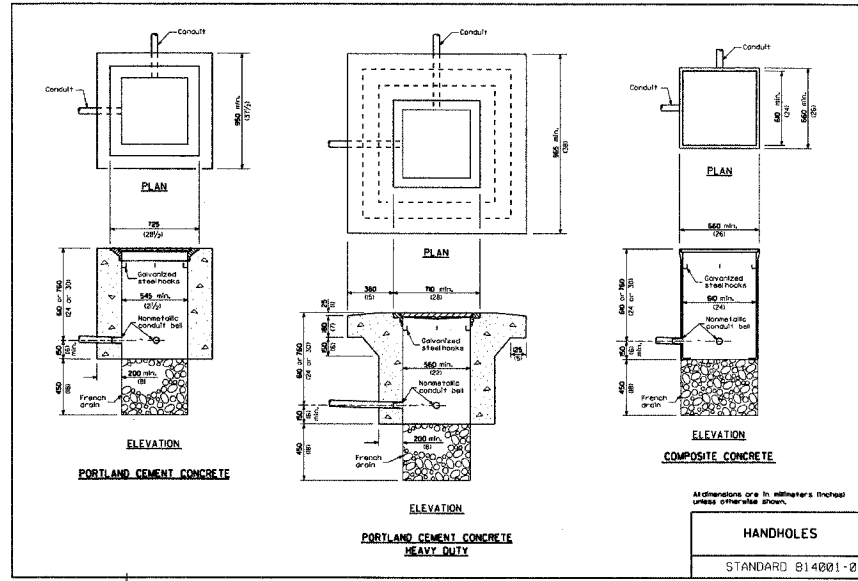

4018.63