

F.A.U. RTE.	SECTION	COUNTY	TOTAL SHEETS	SHEET NO.
8419	99-00048-01-PV	FAYETTE	142	84
STA.	TO STA.			
FED. ROAD DIST. NO.	ILLINOIS FED. AID PROJECT			
CONTRACT NO. 95500				

**GENERAL NOTES:**

- METHOD OF INSTALLATION, MATERIAL, CONSTRUCTION, AND OTHER ITEMS NECESSARY TO COMPLETE THE WORK AS SHOWN HERE IN SHALL CONFORM TO THE REQUIREMENTS OF THE "STANDARD SPECIFICATION FOR WATER AND SEWER MAIN CONSTRUCTION (ION ILLINOIS) FIFTH EDITION, MAY 1998.
- TRENCH BOX SHALL NOT EXTEND BELOW TOP OF PIPE UNLESS OTHERWISE SPECIFIED.
- WATERMAIN & CASING PIPE SHALL BE AWWA C900, DR18, PVC WITH GASKETED PUSH ON JOINTS PER ASTM D3139 UNLESS NOTED OTHERWISE. CASING SPACERS TO BE USED IN ALL CASING AT THE SPACING RECOMMENDED BY MANUFACTURER.
- GRANULAR CRADLE SHALL BE PER ASTM D2321 CASE III WITH A MAXIMUM SIZE OF 0.50 INCH. ALL FITTINGS SHALL BE DUCTILE IRON.
- WATERMAIN SHALL BE DISINFECTED PER STANDARD SPEC. 41-2.13 EXCEPT TABLET DISINFECTION WILL NOT BE ALLOWED.
- ALL VALVE BOXES SHALL BE 5", CAST IRON WITH CAST IRON COVERS INDICATING "WATER".
- GATE VALVES SHALL BE MUELLER RESILIENT SEAT MEETING THE REQUIREMENTS OF AWWA C509 WITH MECHANICAL JOINTS.
- FIRE HYDRANTS SHALL BE MUELLER SUPER CENTURION. NOZZLES SHALL HAVE CITY'S THREADS. FLUSHING HYDRANTS SHALL BE MUELLER 2. 0.125 INCH FLUSH HYDRANTS.
- PIPE SHALL BE PRESSURE TESTED AT A HYDROSTATIC PRESSURE OF 100 PSI. THE DURATION OF THE PRESSURE TEST SHALL BE NOT LESS THAN FOUR(4) HOURS.
- NO. 12 COPPER WIRE SHALL BE INSTALLED ALONG TOP OF WATERLINE.
- UTILITIES ARE SHOWN IN ACCORDANCE WITH THE BEST AVAILABLE INFORMATION AND THEIR TRUE LOCATION IS NOT GUARANTEED TO BE SHOWN ON PLANS OR AS SHOWN ON PLANS. CALL J.U.L.I.E. CONTRACTOR IS RESPONSIBLE FOR MAINTAINING. EXISTING UTILITY SERVICES AS INCLUDED IN THE PAY ITEM TO BE CONSTRUCTED TO THE CONTRACT. THE CONTRACTOR SHOULD ADJUST DEPTH AS NECESSARY TO AVOID EXISTING UTILITIES AND PROVIDE EXTENSIONS FOR VALVE BOXES, HYDRANTS, ETC. AS NECESSARY. NO ADDITIONAL COMPENSATION WILL BE ALLOWED FOR THIS WORK.
- MINIMUM DEPTH OF WATERMAIN SHALL BE 3'-6" TO THE TOP OF PIPE UNLESS OTHERWISE NOTED.
- ALL FITTINGS SHALL BE RESTRAINED WITH PRECAST CONCRETE THRUST BLOCK, UNLESS NOTED OTHERWISE. ALL VALVES SHALL BE RESTRAINED WITH MECHANICAL RESTRAINERS. NON BLOCKED RESTRAINED JOINT FITTINGS SHALL BE EBAA MECHANICAL JOINT RESTRAINT GLANDS.
- EROSION CONTROL PRACTICES SHALL BE CONSTRUCTED IN ACCORDANCE WITH THE ILLINOIS URBAN MANUAL BY THE ILLINOIS ENVIRONMENTAL PROTECTION AGENCY, 1995 AS AMENDED. IT WAS PREPARED BY THE U.S. DEPARTMENT OF AGRICULTURE, NATURAL RESOURCES, CONSERVATION SERVICES.
- ALL EXCAVATION SHALL BE KEPT Dewatered DURING CONSTRUCTION OPERATIONS UNTIL BACKFILL IS IN PLACE.
- CONSTRUCTION OPERATIONS WILL BE REQUIRED ADJACENT TO PRIVATE PROPERTY. THE OWNER DOES NOT AND WILL NOT ASSUME RESPONSIBILITY FOR ANY DAMAGE TO PRIVATE PROPERTY. CLEANUP OF CONSTRUCTION AREAS IS CONSIDERED TO BE AN ESSENTIAL AND INCLUDED IN THE COST OF CONSTRUCTED PAY ITEM.
- ALL WORK BY CITY BORER PAY QUANTITIES DO NOT APPLY.

D	A	B	C	E	F	G	H	J	K	L
4" & 6"	8"	11"	1'-3"	8"	8"	8"	3"	2'-6"	2'-6"	3'-0"
8"	9"	1'-2"	1'-8"	9"	10"	9"	3"	3'-0"	2'-9"	4'-0"
10"	10"	1'-6"	2'-1"	10"	1'-0"	1'-0"	3"	4'-0"	3'-0"	4'-6"
12"	1'-0"	1'-8"	2'-6"	11"	1'-3"	1'-0"	3"	4'-6"	3'-6"	4'-9"
16"	1'-2"	2'-4"	3'-4"	1'-3"	1'-8"	1'-4"	4"	5'-2"	4'-0"	6'-6"
20"	1'-3"	3'-0"	4'-2"	1'-6"	2'-1"	1'-9"	4"	5'-6"	4'-9"	8'-0"
24"	1'-4"	3'-6"	5'-0"	1'-8"	2'-6"	2'-0"	5"	6'-0"	5'-6"	9'-6"

MINIMUM REQUIRED BEARING DIMENSIONS.

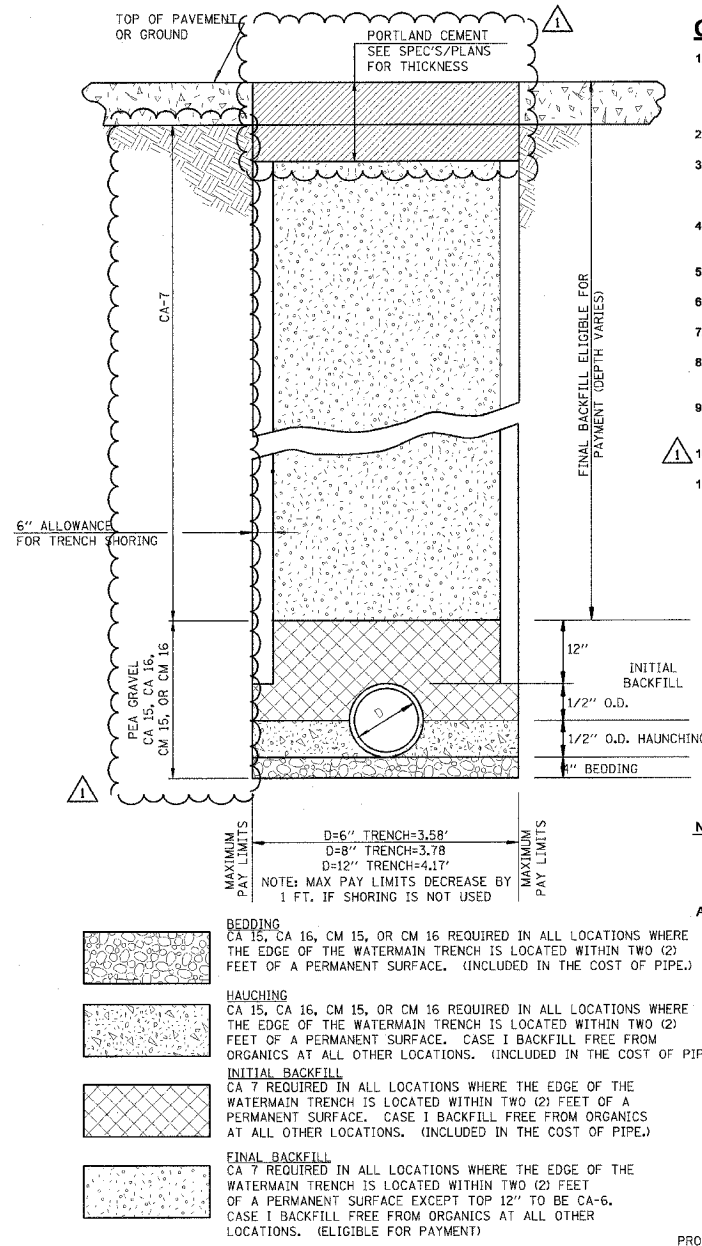

- TRENCHING DETAIL**
- BEDDING:** CA 15, CA 16, CM 15, OR CM 16 REQUIRED IN ALL LOCATIONS WHERE THE EDGE OF THE WATERMAIN TRENCH IS LOCATED WITHIN TWO (2) FEET OF A PERMANENT SURFACE. (INCLUDED IN THE COST OF PIPE.)
  - HAUNCHING:** CA 15, CA 16, CM 15, OR CM 16 REQUIRED IN ALL LOCATIONS WHERE THE EDGE OF THE WATERMAIN TRENCH IS LOCATED WITHIN TWO (2) FEET OF A PERMANENT SURFACE. CASE I BACKFILL FREE FROM ORGANICS AT ALL OTHER LOCATIONS. (INCLUDED IN THE COST OF PIPE.)
  - INITIAL BACKFILL:** CA 7 REQUIRED IN ALL LOCATIONS WHERE THE EDGE OF THE WATERMAIN TRENCH IS LOCATED WITHIN TWO (2) FEET OF A PERMANENT SURFACE. CASE I BACKFILL FREE FROM ORGANICS AT ALL OTHER LOCATIONS. (INCLUDED IN THE COST OF PIPE.)
  - FINAL BACKFILL:** CA 7 REQUIRED IN ALL LOCATIONS WHERE THE EDGE OF THE WATERMAIN TRENCH IS LOCATED WITHIN TWO (2) FEET OF A PERMANENT SURFACE EXCEPT TOP 12" TO BE CA-6. CASE I BACKFILL FREE FROM ORGANICS AT ALL OTHER LOCATIONS. (ELIGIBLE FOR PAYMENT)

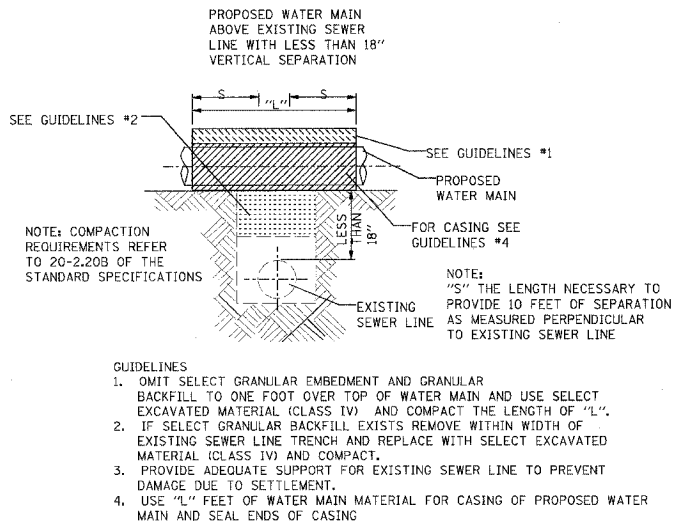
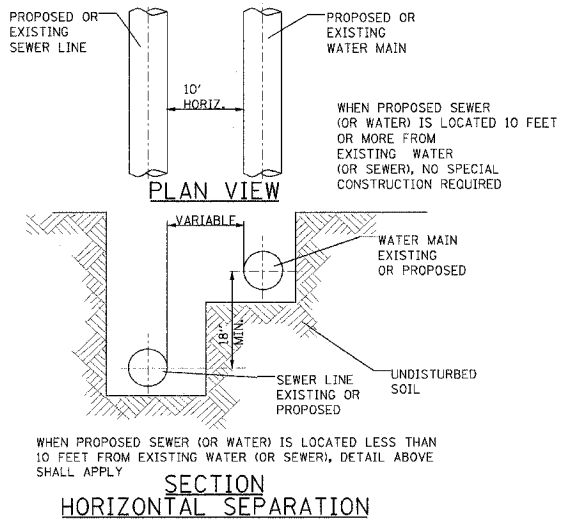
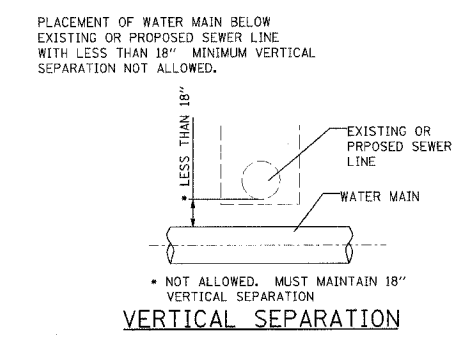
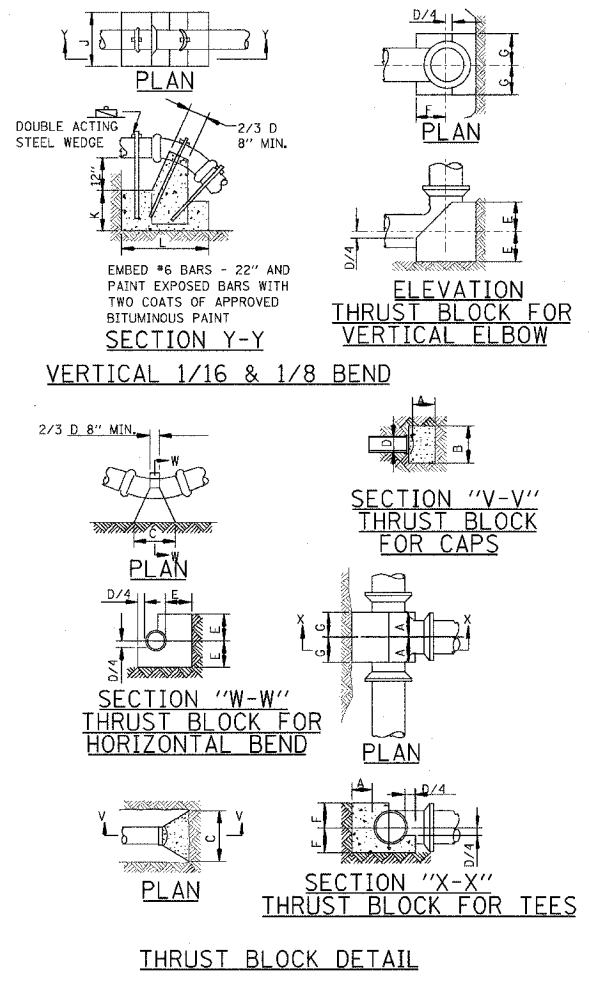
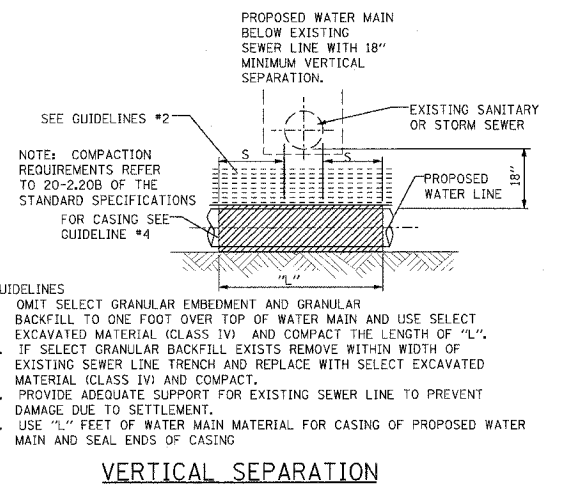
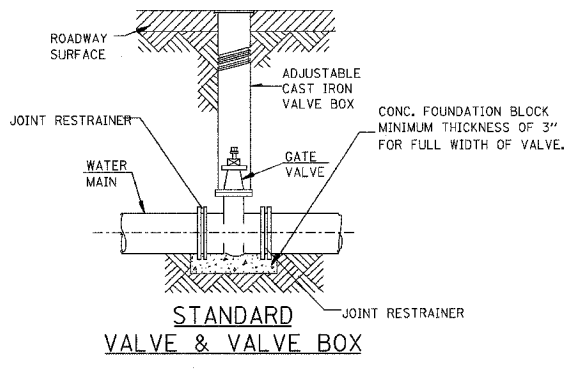
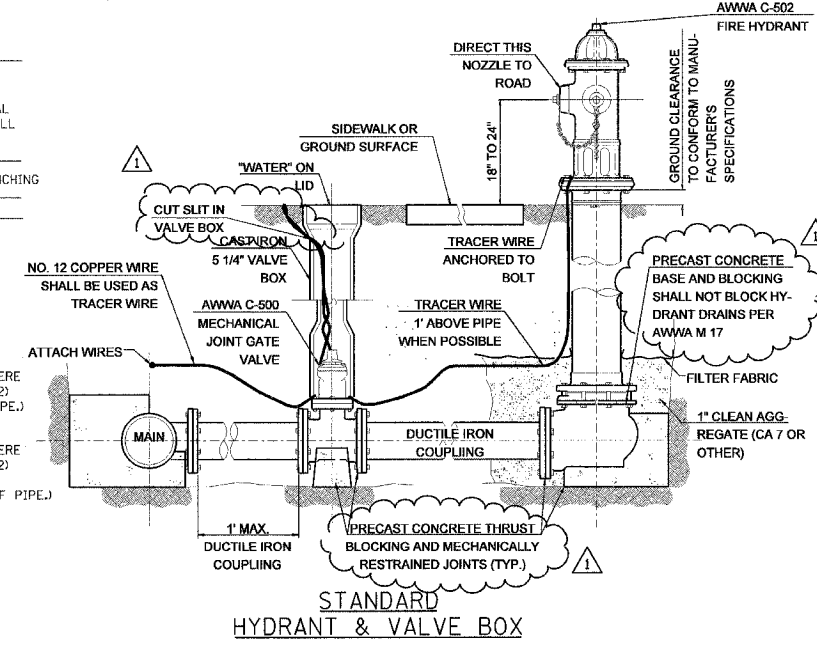

NAME	DATE
JAW	4-13-07

REVISED (4-13-07)

ILLINOIS DEPARTMENT OF TRANSPORTATION

**TYPICAL WATER DETAILS**

SCALE: VERT. HORIZ. DATE

DRAWN BY KOJ CHECKED BY BWC

CADD FILE: /4812/W\_detailed.dgn  
PLOTTED: 4/16/2007

Revised 4-17-07