

F.A.S.	SECTION	COUNTY	TOTAL SHEETS	SHEET NO.
VAR.	06-00086-00-RS	WHITE	3	1
FED. ROAD DIST. NO. 9	ILLINOIS	VARIOUS CITY STREETS		
LEC JOB # H06L017CA				

STATE OF ILLINOIS
DEPARTMENT OF TRANSPORTATION
DIVISION OF HIGHWAYS
**PLANS FOR PROPOSED
STU**

**F.A.S. VARIOUS SECTION 06-00086-00-RS; CITY OF CARMI WHITE COUNTY
JOB# C-99-509-07 PROJECT NO. M-5010(9)**

INDEX OF SHEETS

SHEET NO.	DESCRIPTION
1	TITLE SHEET
2	SUMMARY OF QUANTITIES, GENERAL NOTES, SCHEDULES, AND MISCELLANEOUS DETAILS
3	TYPICAL SECTIONS AND DETAILS OF INTERSECTIONS

THE FOLLOWING STANDARDS ARE A PART OF THESE PLANS AND ARE INCLUDED AFTER SHEET NO. 4

000001-04	STANDARD SYMBOLS, ABBREVIATIONS & PATTERNS
701501-03	URBAN LANE CLOSURE 2L, 2W UNDIVIDED
702001-06	TRAFFIC CONTROL DEVICES

SUMMARY OF QUANTITIES

CODE NUMBER	ITEM	UNIT	QUANTITY
40600100	BITUMINOUS MATERIALS (PRIME COAT)	GALLON	1304.00
40600300	AGGREGATE (PRIME COAT)	TON	26.00
40600982	HOT-MIX ASPHALT SURFACE REMOVAL - BUTT JOINT	50 YD	322.00
40600990	TEMPORARY RAMP	50 YD	52.00
40603310	HOT-MIX ASPHALT SURFACE COURSE, MIX "C" N50	TON	4746.00
44300100	AREA REFLECTIVE CRACK CONTROL TREATMENT	50 YD	14259.00
60266600	VALVE BOXES TO BE ADJUSTED	EACH	1.00
60300305	FRAMES AND LIDS TO BE ADJUSTED	EACH	3.00
67100100	MOBILIZATION	L SUM	1.00

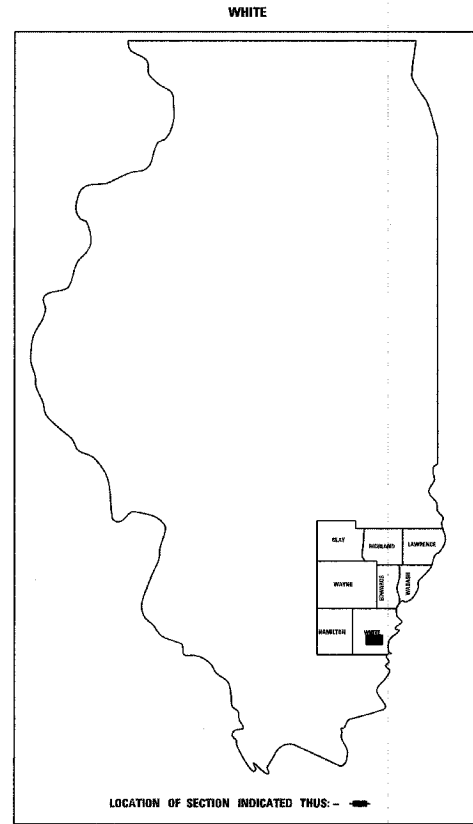
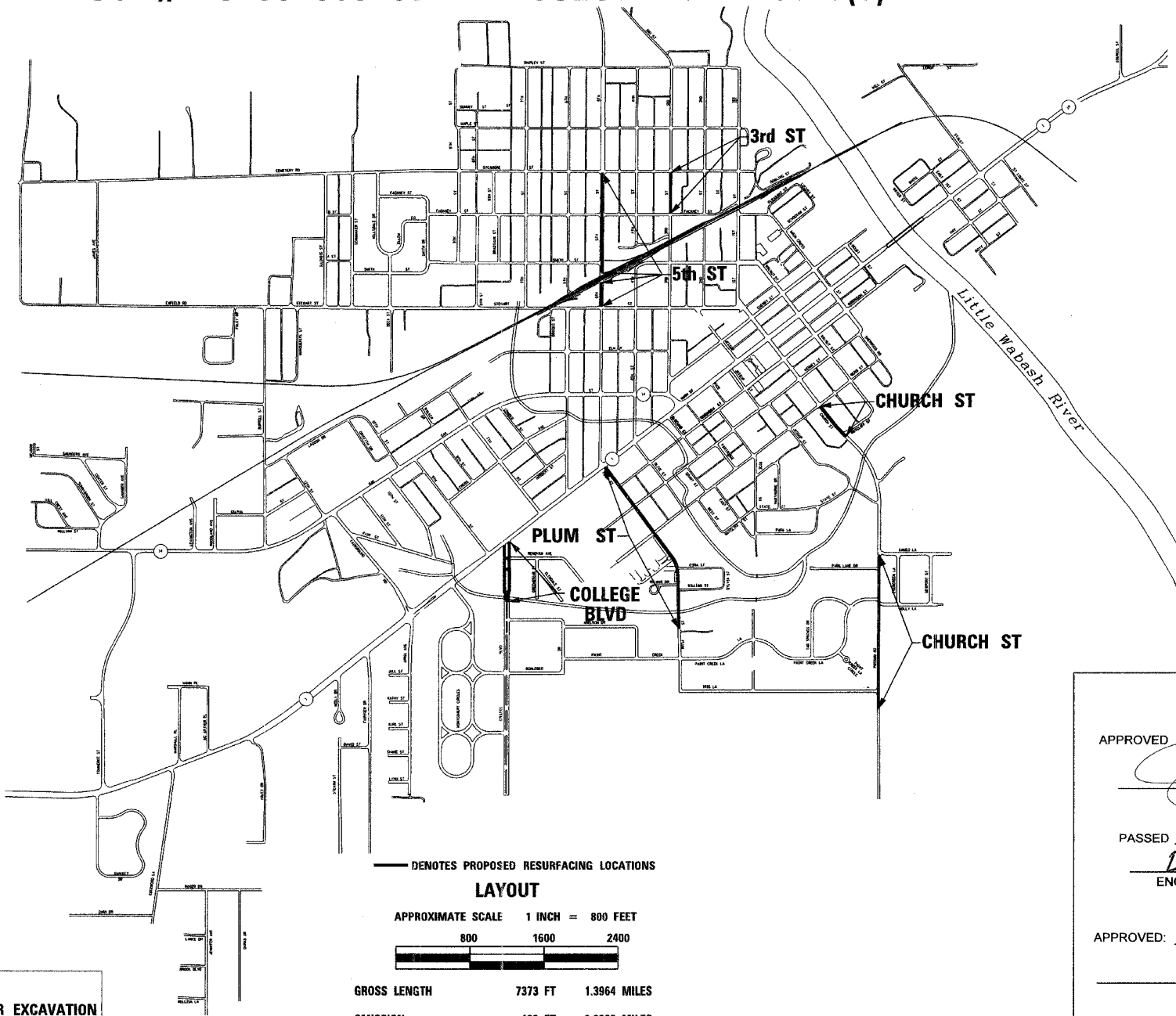

323 W. 3RD ST.
P.O. BOX 160
MT. CARMEL, IL
62863
PHONE:
(618)-262-8651
FAX:
(618)-263-3327

405 W. STATE ST.
SUITE 1
PRINCETON, IN
47670
PHONE:
(812)-386-7611
FAX:
(812)-385-2812



PROFESSIONAL DESIGN FIRM
LAND SURVEY & PROFESSIONAL ENGINEERING CORPORATION
184-000887
(62-032435)(35-002766)

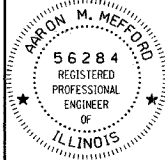

AARON M. MEFFORD
NAME
Aaron Mefford
SIGNATURE
2-7-07
DATE
11-30-07
EXPIRES

STATE OF ILLINOIS
DEPARTMENT OF TRANSPORTATION

APPROVED: 2/7/2007
Paul J. Amin
MAYOR

PASSED: 2/14/07
Dennis W. Hill
ENGINEER OF LOCAL ROADS AND STREETS

APPROVED: 2-16-07
Mary C. Lamie
MARY C. LAMIE, P.E.
DEPUTY DIRECTOR OF HIGHWAYS
REGION FIVE ENGINEER

CONTRACT# 99289
DESIGN CLASS - URBAN ARTERIALS
CURRENT A.D.T. = VARIES (PER STREET)
DESIGN SPEED = 30 MPH

**J.U.L.I.E.
JOINT UTILITY LOCATION INFORMATION FOR EXCAVATION
1-800-892-0123**

SCHEDULE OF NET LENGTH

STREET	FROM	TO	NET LENGTH (FT)
3rd ST (FAU 8782)	FACKNEY ST	SYCAMORE ST	450'
5th ST (FAU 8780)	STEWART ST	SYCAMORE ST	1550'
COLLEGE BLVD (FAU 8779)	SOUTH END CULVERT	MAIN ST	1230'
PLUM ST (FAU 8781)	CHURCH PARK LOT	MAIN ST	2025'
CHURCH ST (FAU 8784)	RATCLIFF ST	WEBB ST	395'
SOUTH CHURCH ST (FAU 8784)	CITY LIMITS	CAMEO ST	1600'

TYPICAL ENTRANCE DETAILS PROPOSED

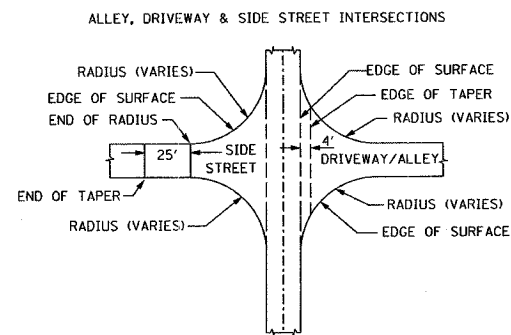

BUTT JOINT DETAIL

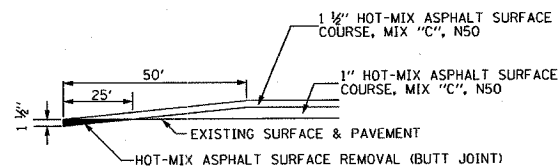

TEMPORARY RAMP DETAIL

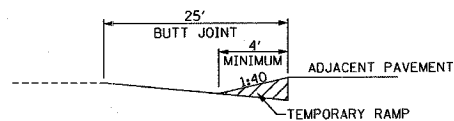

SCHEDULE OF BUTT JOINTS

STREET	LOCATION
5th	NORTH END
COLLEGE NORTH	NORTH END
COLLEGE SOUTH	NORTH END
PLUM	NORTH END

TYPICAL SURFACE TAPER DETAIL

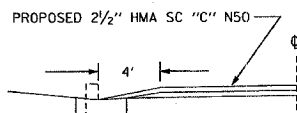

TYPICAL SIDE STREET TAPER DETAIL

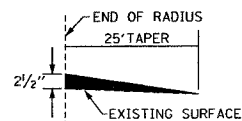

UTILITIES

CENTRAL ILLINOIS PUBLIC SERVICE 207 N. WALNUT ST. ONLEY, IL 62450 618-383-2121	CITY OF CARMi MUNICIPAL BUILDING 225 E. MAIN CARMi, IL 62821 618-382-5555	CONSUMERS GAS 328 INDUSTRIAL AVE. CARMi, IL 62821 618-382-4158	GENERAL TELEPHONE CO. 208 WEST UNION ST. MARION, IL 62959 800-232-2544
	CAPTIAL CABLE 7246 MAIN ST. WADESVILLE, IN 47638 800-729-5660	J.U.L.I.E. 800-892-0123	

GENERAL NOTES:

THIS SECTION CONSISTS OF RESURFACING, AND OTHER MISCELLANEOUS ITEMS NECESSARY TO COMPLETE THE PROJECT, ALL IN ACCORDANCE WITH THE PLANS, SPECIAL PROVISIONS AND "STANDARD SPECIFICATIONS FOR ROAD AND BRIDGE CONSTRUCTION" ADOPTED JANUARY 1, 2007.

THE QUANTITY SHOWN IN THE SUMMARY OF QUANTITIES FOR HOT-MIX ASPHALT SURFACE COURSE, MIX "C", N50, WAS CALCULATED USING 112 POUNDS PER SQUARE YARD FOR ONE INCH OF THICKNESS.

THE HOT-MIX ASPHALT SURFACE COURSE, MIX "C", N50 SHALL HAVE A NOMINAL THICKNESS OF 2 1/2" AND BE PLACED IN TWO LIFTS WITH THE TOP LIFT HAVING MINIMUM THICKNESS OF 1 1/2" ON ALL STREETS.

TEMPORARY RAMPS SHALL BE PLACED AT A 1 TO 40 SLOPE AT LOCATIONS DETERMINED BY THE ENGINEER. THE REMOVAL OF TEMPORARY RAMPS SHALL BE INCLUDED IN THE COST OF THE TEMPORARY RAMP.

HOT-MIX ASPHALT TAPERS FROM 2 1/2" TO 0" SHALL BE CONSTRUCTED FROM THE END OF EACH RADIUS ON EACH OF THE SIDEROADS AS SHOWN ON THIS PAGE OR AS DIRECTED BY THE ENGINEER.

THE QUANTITY SHOWN IN THE SUMMARY OF QUANTITIES FOR BITUMINOUS MATERIALS (PRIME COAT) ALLOWS FOR A COVERAGE OF 0.05 GAL/SQ YD.

THE QUANTITY SHOWN IN THE SUMMARY OF QUANTITIES FOR AGGREGATE (PRIME COAT) ALLOWS FOR A COVERAGE OF 2 LBS/SQ YD.

AREA REFLECTIVE CRACK CONTROL TREATMENT IS TO BE PLACED AFTER THE FIRST LIFT AND BEFORE THE SECOND LIFT HAS BEEN PLACED.

UTILITIES TO BE ADJUSTED

STREET	QUANTITY & DESCRIPTION
3rd	2 STORM MH
5th	1 MH
SOUTH CHURCH	1 WV

NOTE: THE SCHEDULE ABOVE INCLUDES KNOWN MANHOLES, WATER VALVE BOXES, AND STORM INLETS AND WILL BE PAID FOR AT THE CONTRACT UNIT PRICE FOR THE RESPECTIVE ITEM. THE ABOVE QUANTITIES ARE SHOWN IN THE RESPECTIVE PAY ITEMS TO BE ADJUSTED IN THE SUMMARY OF QUANTITIES.

SCHEDULE OF AREA REFLECTIVE CRACK CONTROL TREATMENT

STREET	FROM	TO	QUANTITY
3rd	SYCAMORE	FACKNEY	1,225 SY
5th	SYCAMORE	STEWART	6,200 SY
COLLEGE (NORTH BOUND)	MAIN ST	SOUTH END CULVERT	3,417 SY
COLLEGE (SOUTH BOUND)	MAIN ST	SOUTH END CULVERT	3,417 SY

AREA REFLECTIVE CRACK CONTROL TREATMENT DETAIL

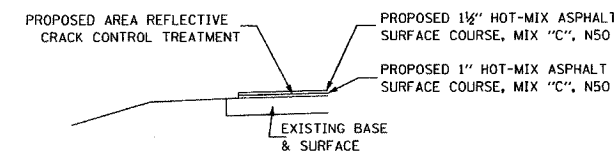

3rd FROM FACKNEY TO SYCAMORE ST

TYPICAL CROSS SECTION EXISTING

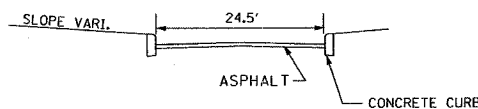

TYPICAL CROSS SECTION PROPOSED

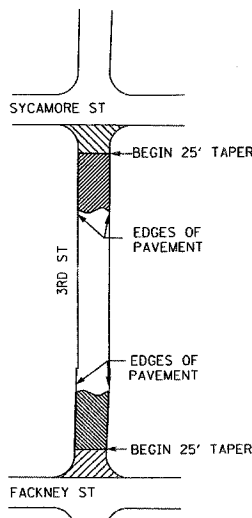
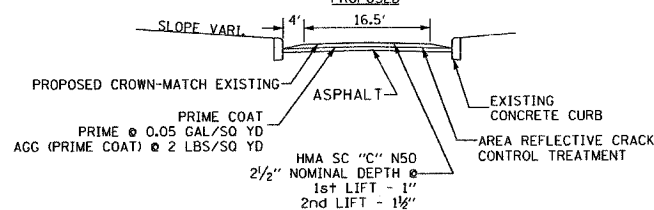

5th FROM STEWART TO SYCAMORE ST

TYPICAL CROSS SECTION EXISTING

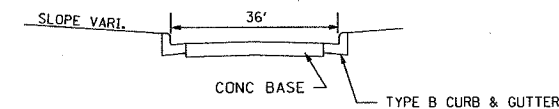

TYPICAL CROSS SECTION PROPOSED

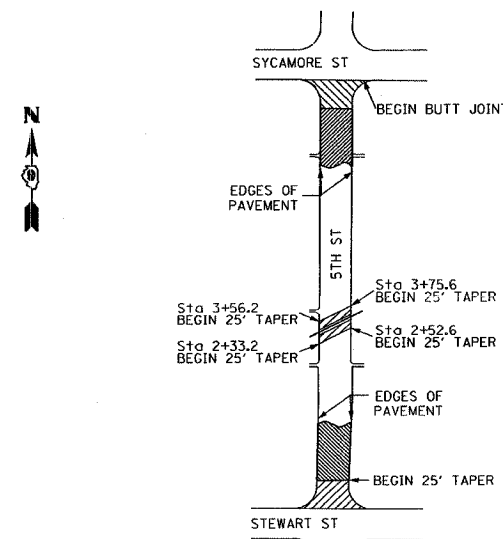
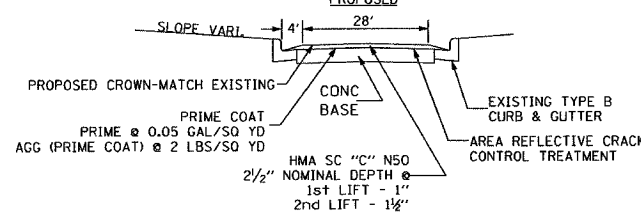

323 W. 3RD ST.
P.O. BOX 160
MT. CARMEL, IL
62863
PHONE:
(618)-262-8651
FAX:
(618)-263-3327

405 W. STATE ST.
SUITE 1
PRINCETON, IN
47770
PHONE:
(812)-386-7611
FAX:
(812)-385-2812



PROFESSIONAL DESIGN FIRM
LAND SURVEY &
PROFESSIONAL
ENGINEERING
CORPORATION
184-000887
(62-032435)(35-002769)

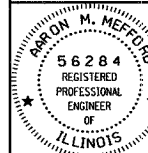

AARON M. MEFFORD
NAME
Aaron Mefford
SIGNATURE
7-7-07
DATE
11-30-07
EXPIRES

CHURCH ST FROM WEBB TO RATCLIFF ST

TYPICAL CROSS SECTION EXISTING

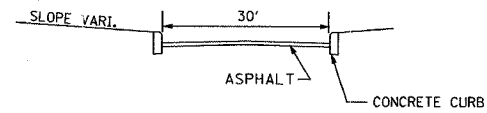

TYPICAL CROSS SECTION PROPOSED

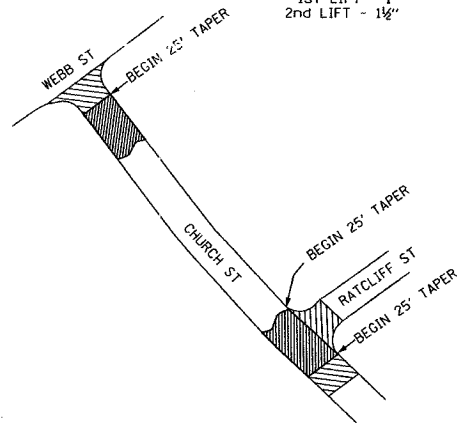
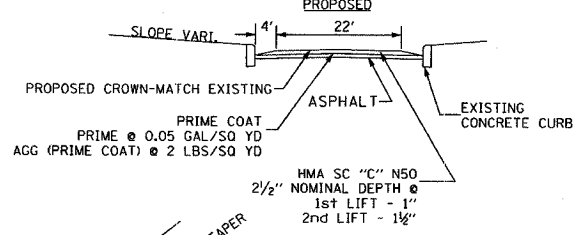

SO. CHURCH FROM N. PARK TO END

TYPICAL CROSS SECTION EXISTING

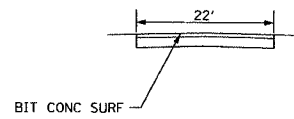

TYPICAL CROSS SECTION PROPOSED

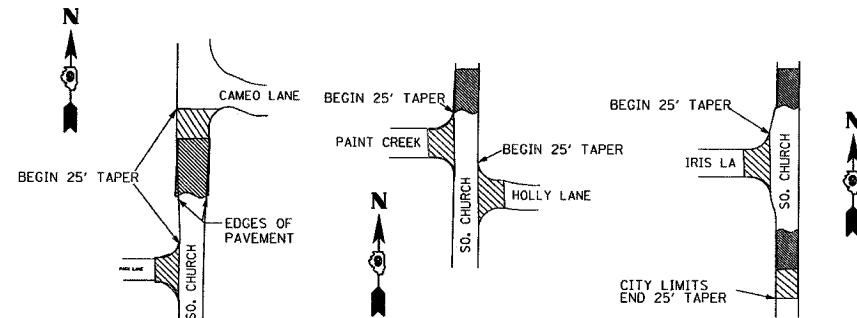
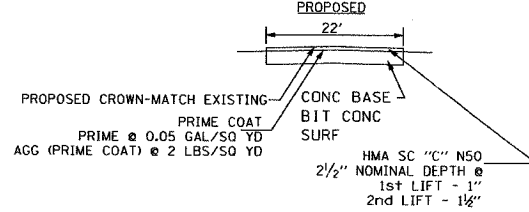

PLUM FROM MAIN ST TO CHURCH PARKING LOT

TYPICAL CROSS SECTION EXISTING

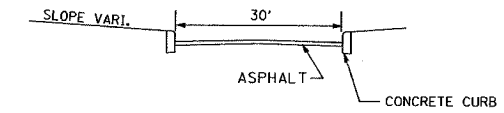

TYPICAL CROSS SECTION PROPOSED

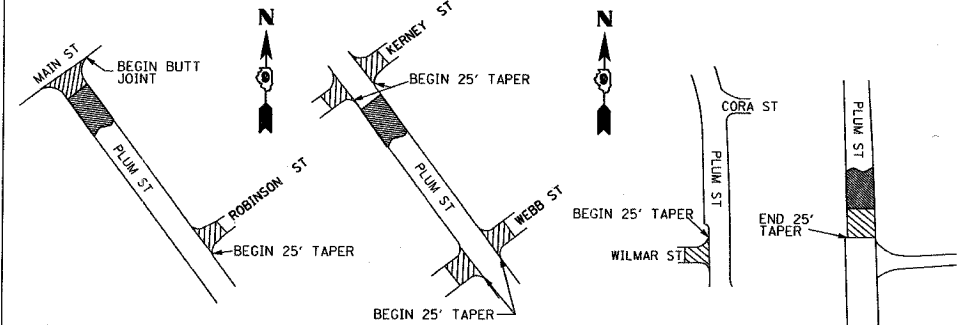
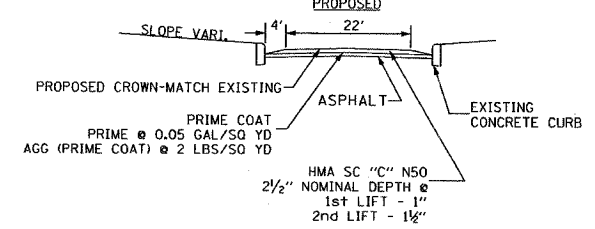

SECTION	COUNTY	TOTAL SHEETS	SHEET NO.
06-00086-00-RS	WHITE	3	3
CITY OF CARM	VARIOUS CITY STREETS		
FED. RD. DIST. NO. 9	LEC JOB NO. H061017CA		

323 W. 3RD ST.
P.O. BOX 160
MT. CARMEL, IL
62863
PHONE:
(618)-262-8651
FAX:
(618)-263-3327

405 W. STATE ST.
SUITE 1
PRINCETON, IN
47670
PHONE:
(812)-386-7611
FAX:
(812)-385-2812



PROFESSIONAL DESIGN FIRM
LAND SURVEY &
PROFESSIONAL ENGINEERING CORPORATION

184-000887
(62-032435)(35-002769)

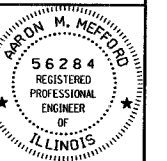

AARON M. MEFFORD
NAME
Aaron Mefford
SIGNATURE
2-7-07
DATE
11-30-07
EXPIRES

COLLEGE FROM MAIN TO SO. END CULVERT

TYPICAL CROSS SECTION EXISTING

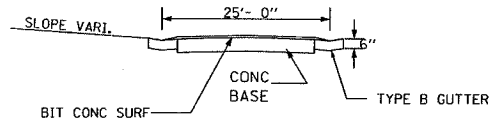

TYPICAL CROSS SECTION PROPOSED

