

LEGEND

- ⊙ DUAL ENTRY PHASE
- ⊙ PEDESTRIAN PHASE
- ⊙ SINGLE ENTRY PHASE
- ⊙ OL OVERLAP
- * NUMBER REFERS TO ASSOCIATED PHASE

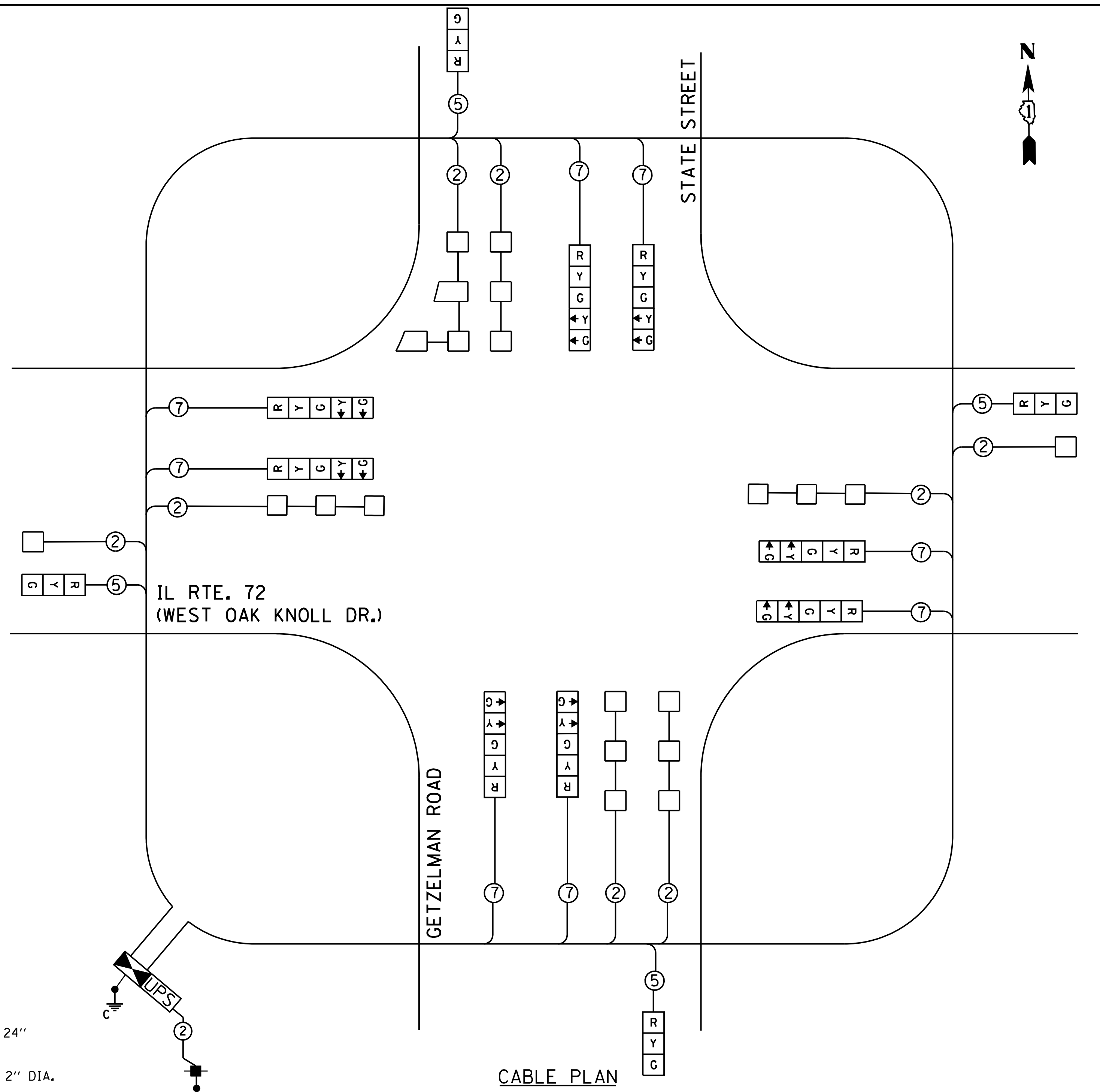

SCHEDULE OF QUANTITIES

QUANTITY	UNIT	ITEM
2	CAL MO	CHANGEABLE MESSAGE SIGN
32	SO FT	SIGN PANEL - TYPE 1
33	SO FT	SIGN PANEL - TYPE 2
150	FOOT	THERMOPLASTIC PAVEMENT MARKING - LINE 24"
300	SO FT	PAVEMENT MARKING REMOVAL
1	EACH	SERVICE INSTALLATION - POLE MOUNTED
597	FOOT	UNDERGROUND CONDUIT, GALVANIZED STEEL, 2" DIA.
5	EACH	HANDHOLE
1	EACH	HEAVY-DUTY HANDHOLE
1	EACH	MAINTENANCE OF EXISTING TRAFFIC SIGNAL INSTALLATION
1	EACH	FULL-ACTUATED CONTROLLER AND TYPE IV CABINET
350	FOOT	SPAN WIRE
350	FOOT	TETHER WIRE
927	FOOT	ELECTRIC CABLE IN CONDUIT, LEAD-IN, NO. 14 1 PAIR
552	FOOT	ELECTRIC CABLE AERIAL SUSPENDED, SIGNAL, NO. 14 5C
1,102	FOOT	ELECTRIC CABLE AERIAL SUSPENDED, SIGNAL, NO. 14 7C
72	FOOT	ELECTRIC CABLE AERIAL SUSPENDED, SERVICE, NO. 6 2 C
785	FOOT	ELECTRIC CABLE AERIAL SUSPENDED, LEAD-IN, NO. 14 1 PAIR
8	EACH	INDUCTIVE LOOP DETECTOR
917	FOOT	DETECTOR LOOP, TYPE I
1	EACH	REMOVE EXISTING FLASHING BEACON INSTALLATION COMPLETE
4	EACH	TEMPORARY WOOD POLE, 45 FEET, CLASS 5
1	EACH	UNINTERRUPTIBLE POWER SUPPLY, SPECIAL
4	EACH	SIGNAL HEAD, LED, 1-FACE, 3-SECTION, SPAN WIRE MOUNTED
8	EACH	SIGNAL HEAD, LED, 1-FACE, 5-SECTION, SPAN WIRE MOUNTED
103	SO FT	TEMPORARY INFORMATION SIGNING

I. D. O. T.
 TRAFFIC SIGNAL INSTALLATION
 ELECTRICAL SERVICE REQUIREMENTS

TYPE	NO. LAMPS	WATTAGE		% OPERATIONS	TOTAL WATTAGE
		INCAND.	LED		
SIGNAL (RED)	12	135	17	0.50	102
(YELLOW)	12	135	25	0.25	75
(GREEN)	12	135	15	0.25	45
ARROW	16	135	12	0.10	20
PED. SIGNAL		90	25	1.00	--
CONTROLLER	1	100	100	1.00	100
ILLUM. SIGN		252	25	0.05	--
VIDEO SYSTEM		150	-	1.00	--
FLASHER LED					
TOTAL =					342

ENERGY COSTS- BILLED TO: IDOT DISTRICT 1
 201 WEST CENTER COURT
 SCHAMBURG, IL 60196-1096

ENERGY SUPPLY - CONTACT MIKE LENOX
 PHONE 815-490-2869
 COMPANY COMED

RESTORATION OF WORK AREA, RESTORATION OF THE TRAFFIC SIGNAL WORK AREA SHALL BE INCLUDED IN THE RELATED PAY ITEM SUCH AS FOUNDATION, CONDUIT, HANDHOLE, TRENCH AND BACKFILL, ETC., AND NO EXTRA COMPENSATION SHALL BE ALLOWED. ALL ROADWAY SURFACES SUCH AS SHOULDERS, MEDIAN, SIDEWALKS, PAVEMENT ETC. SHALL BE REPLACED IN KIND. ALL DAMAGE TO MOWED LAWNS SHALL BE REPLACED WITH AN APPROVED SOD, AND ALL DAMAGE TO UNMOWED FIELDS SHALL BE SEEDD IN ACCORDANCE WITH STANDARD SPECIFICATIONS 252 AND 250 RESPECTIVELY.