

**PLAN**

SN 075-0047

REMOVE EXISTING NEOPRENE EXP. JOINT AND SANDBLAST CLEAN PRIOR TO INSTALLING THE PROPOSED SILICONE JOINT SEALER

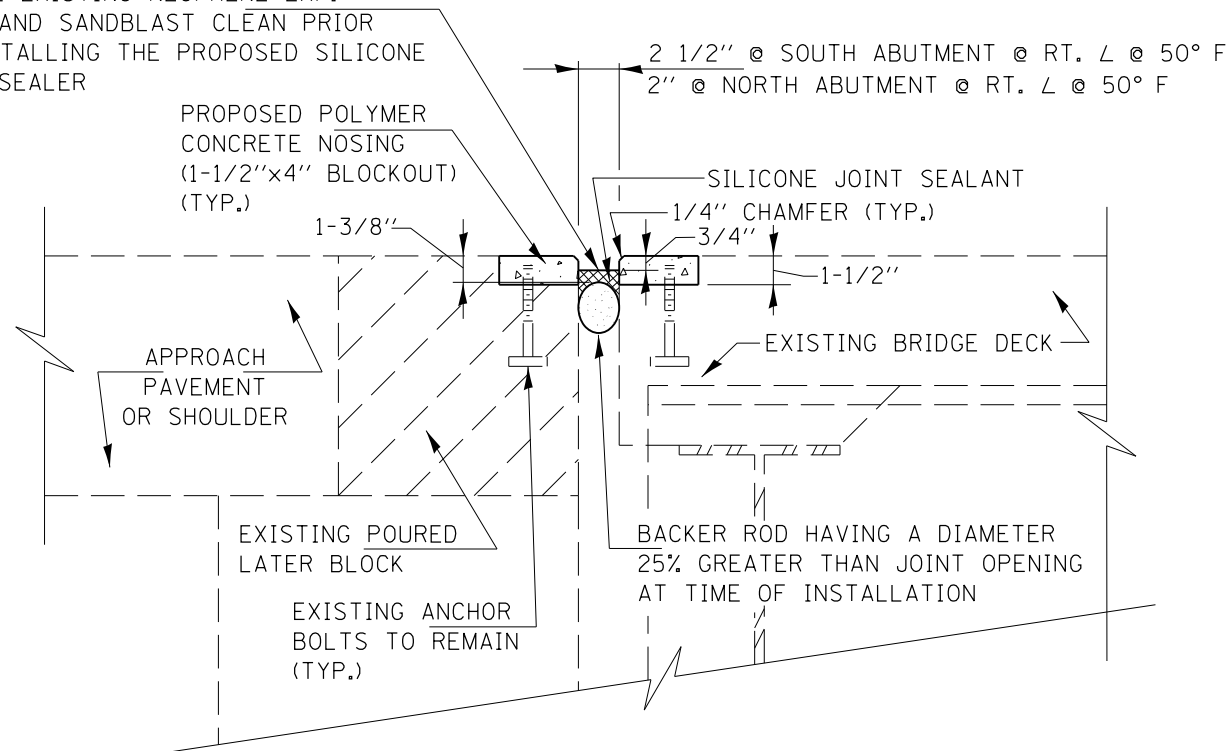

**SECTION A-A**  
SILICONE JOINT DETAIL

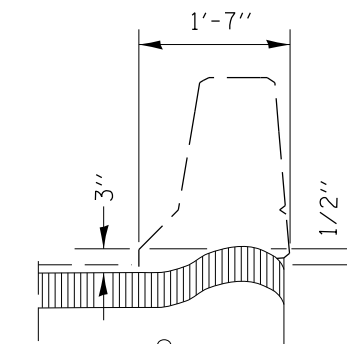

**TYPICAL END OF SEAL TREATMENT**

**BILL OF MATERIAL**

ITEM	UNIT	TOTAL
SILICONE JOINT SEALER, 2"	FOOT	74
SILICONE JOINT SEALER, 2 1/2"	FOOT	74
POLYMER CONCRETE	CU. FT.	12.5

FILE NAME =	USER NAME = sparksgw	DESIGNED -	REVISED -
ei:\pw\work\p\idot\sparksgw\0216263\067243-sht-detail.dgn		DRAWN -	REVISED -
		CHECKED -	REVISED -
		DATE -	REVISED -

STATE OF ILLINOIS  
DEPARTMENT OF TRANSPORTATION

**JOINT REPAIR DETAILS**

SCALE: SHEET NO. OF SHEETS STA. TO STA.

F.A.P. RTE.	SECTION	COUNTY	TOTAL SHEETS	SHEET NO.
304	4RS-3, BR-1	PIKE	41	31
CONTRACT NO. 72243				
ILLINOIS FED. AID PROJECT				