

EXISTING ISLAND REMOVAL ITEMS:  
 CONCRETE CURB & GUTTER REMOVAL = 56.0 FT  
 CONCRETE MEDIAN REMOVAL = 111.1 SQ FT  
 PAVEMENT REMOVAL (INCLUDES NECESSARY  
 SAWCUTS) = 14.9 SQ YD  
 PROPOSED ISLAND ITEMS:  
 COMBINATION CONCRETE CURB & GUTTER,  
 TYPE M 6.24 = 48.0 FT  
 COMBINATION CONCRETE CURB & GUTTER,  
 TYPE M 6.06 = 22.0 FT  
 CONCRETE MEDIAN SURFACE, 4" = 181.5 SQ FT

EXISTING ISLAND REMOVAL ITEMS:  
 CONCRETE CURB & GUTTER REMOVAL = 49.00 FT  
 CONCRETE MEDIAN REMOVAL = 109.52 SQ FT  
 PAVEMENT REMOVAL (INCLUDES NECESSARY  
 SAWCUTS) = 12.7 SQ YD  
 PROPOSED ISLAND ITEMS:  
 COMBINATION CONCRETE CURB & GUTTER,  
 TYPE M 6.24 = 37.70 FT  
 COMBINATION CONCRETE CURB & GUTTER,  
 TYPE M 6.06 = 18.0 FT  
 CONCRETE MEDIAN SURFACE, 4" = 135.6 SQ FT

 EXISTING CONCRETE CURB & GUTTER AND  
 CONCRETE RAISED MEDIAN TO BE REMOVED

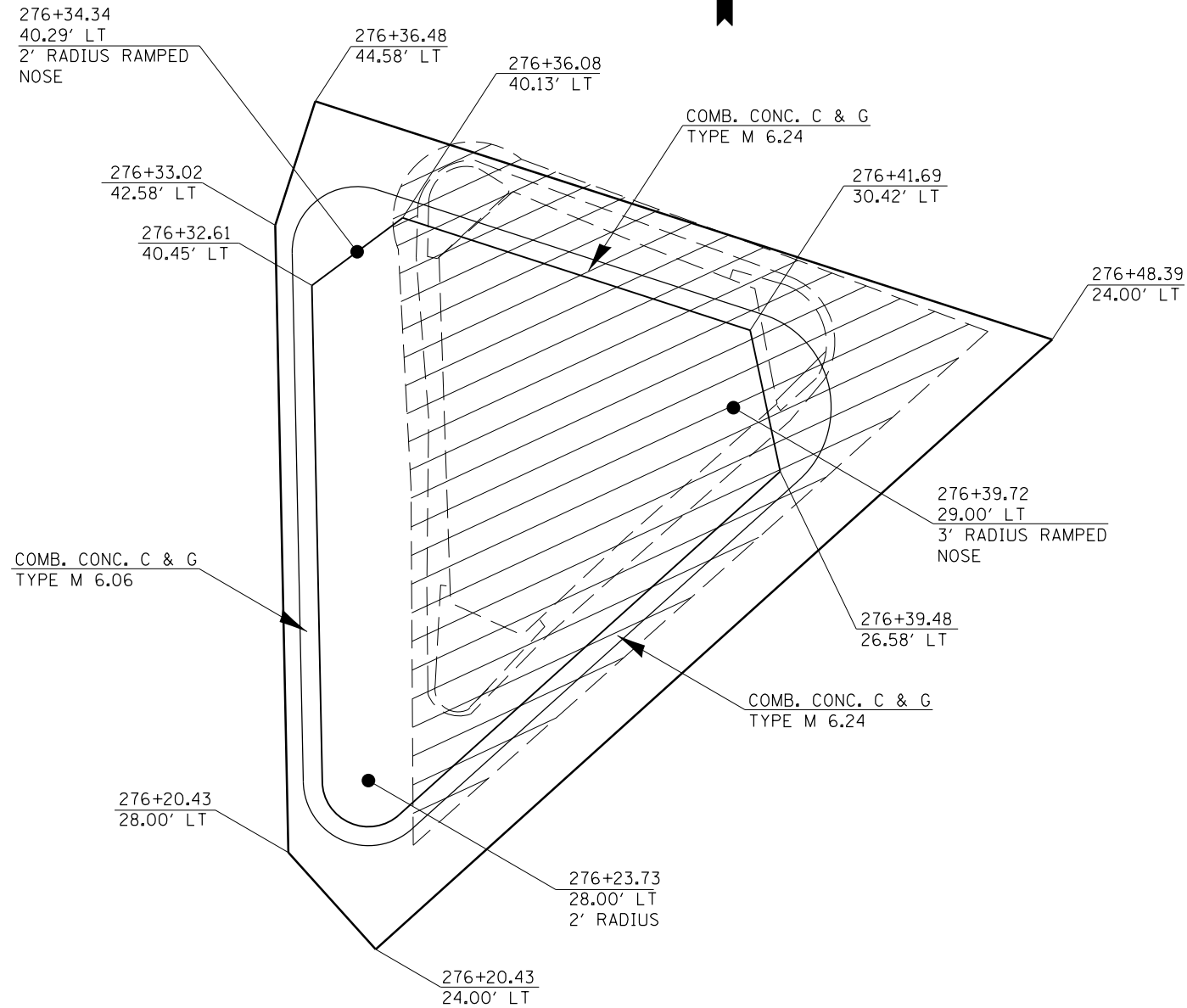

SOUTHWEST QUADRANT ISLAND

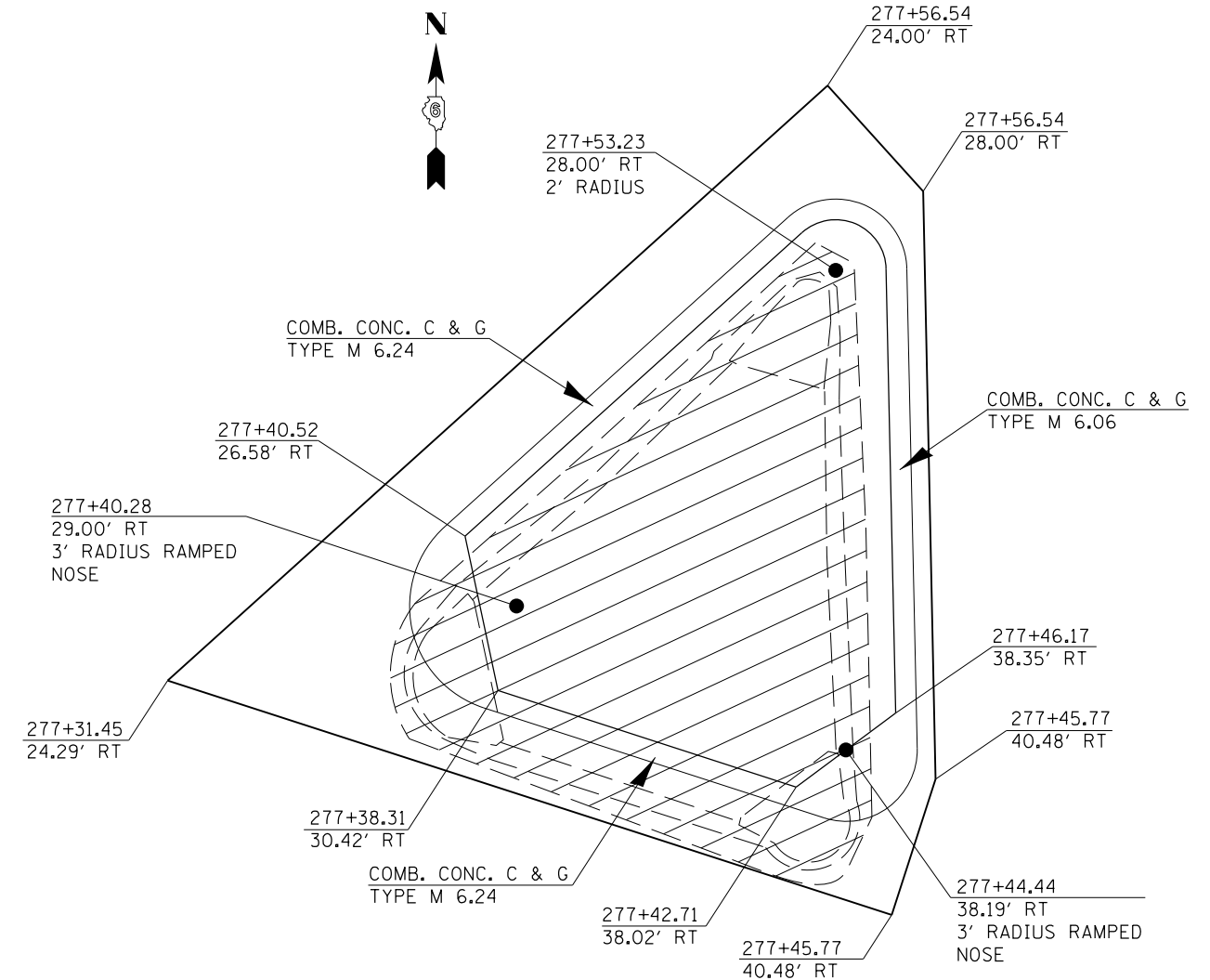

NORTHEAST QUADRANT ISLAND

PROPOSED CONCRETE ISLAND DETAILS FOR THE INTERSECTION OF IL 29 / IL 10

--(E)RS-4, (G)RS-6, I & (F)RS-3, I-1  
 \*\*\*MASON, MENARD

FILE NAME =	USER NAME = sparksgw	DESIGNED - RTS	REVISED -	<b>STATE OF ILLINOIS DEPARTMENT OF TRANSPORTATION</b>	<b>ISLAND LAYOUT DETAILS</b>			F.A.P. RTE.	SECTION	COUNTY	TOTAL SHEETS	SHEET NO.
ei:\pw\work\p1dot\sparksgw\10283522\11m\working file.dgn		DRAWN - RTS	REVISED -		658	.	**	106	61			
PLOT SCALE = 100.0000' / 1in.		CHECKED -	REVISED -		CONTRACT NO. 72F04							
PLOT DATE = Feb-27-2012 02:05:37PM		DATE - 1-26-12	REVISED -		SCALE:	SHEET 1 OF 1 SHEETS	STA. TO STA.	ILLINOIS FED. AID PROJECT				