

# DETAIL OF PRECAST CONCRETE BOX CULVERT END SECTION ASTM C1577

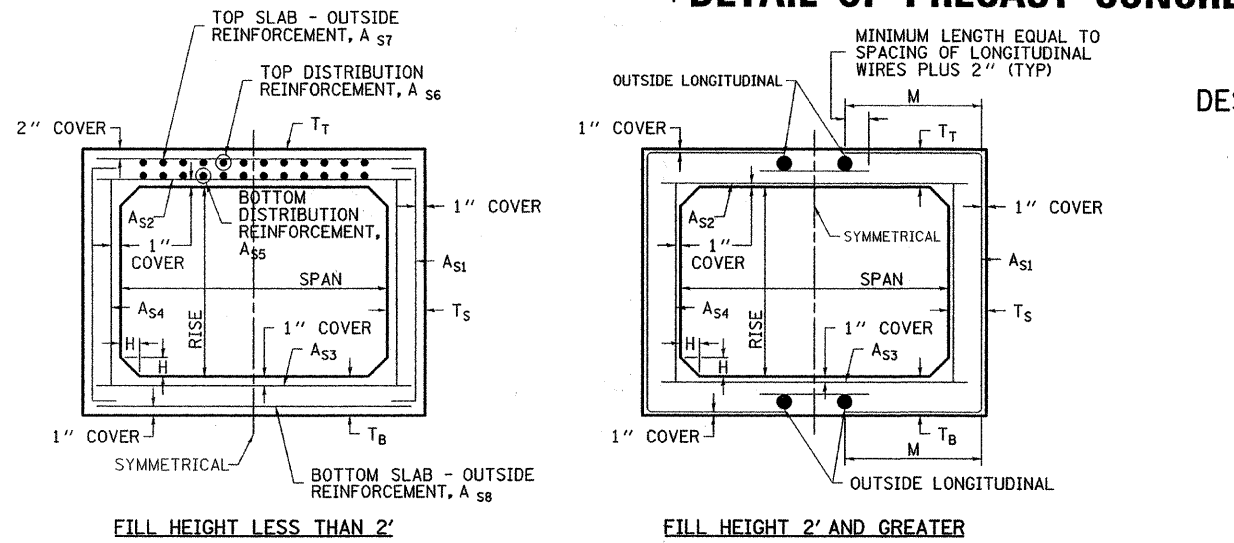

**DESIGN LOADING:**  
 COMBINED EARTH DEAD LOAD  
 AND AASHTO HL-93 LIVE LOAD

**GENERAL NOTES**

SHOP PLANS FOR THE REINFORCEMENT SHALL BE SUBMITTED IN ACCORDANCE WITH THE REQUIREMENTS OF ARTICLE 540.06 OF THE STANDARD SPECIFICATIONS, AND THE CURRENT POLICY MEMORANDUM "QUALITY CONTROL/QUALITY ASSURANCE PROGRAM FOR PRECAST CONCRETE PRODUCTS."

MINIMUM CONCRETE STRENGTH SHALL BE 5000 PSI AFTER 28 DAYS.

THE JOINTS OF THE PRECAST BOX SECTIONS SHALL BE SEALED IN ACCORDANCE WITH ARTICLE 540.06 OF THE STANDARD SPECIFICATIONS FOR ROAD AND BRIDGE CONSTRUCTION.

THE TERMS  $A_{s1}$ ,  $A_{s2}$ ,  $A_{s3}$ ,  $A_{s4}$ ,  $A_{s5}$ ,  $A_{s6}$ ,  $A_{s7}$ , AND  $A_{s8}$ , DENOTE THE REQUIRED STEEL AREAS FOR REINFORCEMENT AS SPECIFIED IN ASTM C1577. REINFORCEMENT SHALL BE WELDED WIRE FABRIC CONFORMING TO AASHTO SPECIFICATIONS M55 (A185) OR M221 (A497), OR REINFORCEMENT BARS, GRADE 60, CONFORMING TO A706.

LIFTING HOLES SHALL BE FILLED IN ACCORDANCE WITH 540.06 OR PROJECT SPECIAL PROVISIONS.

DESIGN FILL HEIGHT (F):

MAXIMUM FILL HEIGHT ( $f_{max}$ ) AND MINIMUM FILL HEIGHT ( $f_{min}$ ) ARE MEASURED BETWEEN THE EXTREME EDGES OF SHOULDER.

$f_{max}/f_{min}$ (FT)	F (FT)
$f_{min} < 2'$	$< 2'$
$2' \leq f_{min} < 3'$	2'
$3' \leq f_{min} < 4'$	3'
$f_{min} > 4'$	$f_{max}$

DESIGN FILL HEIGHTS APPLY TO ENTIRE CULVERT, INCLUDING EXTENSIONS AND END SECTIONS.

CULVERT SIZE BOX SECTION S x R (FT)	DIMENSIONS*								SLOPE Y: X	
	THICKNESS (IN)			A	B	E	F	G		H
	T <sub>+</sub>	T <sub>b</sub>	T <sub>s</sub>	FT - IN	FT - IN	FT - IN	FT - IN	FT - IN		FT - IN
3 x 2	7	6	4	3 - 8	3 - 1	3 - 0	3 - 0	1 - 0	1 - 0	1:3
3 x 3	7	6	4	3 - 8	4 - 1	2 - 0	4 - 0	1 - 8	1 - 4	1:3
4 x 2	7.5	6	5	4 - 10	3 - 1.5	3 - 0	3 - 0	1 - 0	1 - 0	1:3
4 x 3	7.5	6	5	4 - 10	4 - 1.5	2 - 0	4 - 0	1 - 8	1 - 4	1:3
4 x 4	7.5	6	5	4 - 10	5 - 1.5	2 - 0	4 - 0	2 - 0	2 - 0	1:2
5 x 3	8	7	6	6 - 0	4 - 3	2 - 0	4 - 0	1 - 8	1 - 4	1:3
5 x 4	8	7	6	6 - 0	5 - 3	2 - 0	4 - 0	2 - 0	2 - 0	1:2
5 x 5	8	7	6	6 - 0	6 - 3	2 - 0	4 - 0	3 - 0	2 - 0	1:2
6 x 3	8	7	7	7 - 2	4 - 3	2 - 0	4 - 0	1 - 8	1 - 4	1:3
6 x 4	8	7	7	7 - 2	5 - 3	2 - 0	4 - 0	2 - 0	2 - 0	1:2
6 x 5	8	7	7	7 - 2	6 - 3					
6 x 6	8	7	7	7 - 2	7 - 3	2 - 0	6 - 0	3 - 0	3 - 0	1:2
7 x 4	8	8	8	8 - 4	5 - 4	2 - 0	4 - 0	2 - 0	2 - 0	1:2
7 x 5	8	8	8	8 - 4	6 - 4					
7 x 6	8	8	8	8 - 4	7 - 4					
7 x 7	8	8	8	8 - 4	8 - 4					
8 x 4	8	8	8	9 - 4	5 - 4	2 - 0	4 - 0	2 - 0	2 - 0	1:2
8 x 5	8	8	8	9 - 4	6 - 4					
8 x 6	8	8	8	9 - 4	7 - 4					
8 x 7	8	8	8	9 - 4	8 - 4					
8 x 8	8	8	8	9 - 4	9 - 4					
9 x 5	9	9	9	10 - 6	6 - 6					
9 x 6	9	9	9	10 - 6	7 - 6					
9 x 7	9	9	9	10 - 6	8 - 6					
9 x 8	9	9	9	10 - 6	9 - 6					
9 x 9	9	9	9	10 - 6	10 - 6					
10 x 5	10	10	10	11 - 8	6 - 8					
10 x 6	10	10	10	11 - 8	7 - 8					
10 x 7	10	10	10	11 - 8	8 - 8					
10 x 8	10	10	10	11 - 8	9 - 8					
10 x 9	10	10	10	11 - 8	10 - 8					
10 x 10	10	10	10	11 - 8	11 - 8					
11 x 4	11	11	11	12 - 10	5 - 10					
11 x 6	11	11	11	12 - 10	7 - 10					
11 x 8	11	11	11	12 - 10	9 - 10					
11 x 10	11	11	11	12 - 10	11 - 10					
11 x 11	11	11	11	12 - 10	12 - 10					
12 x 4	12	12	12	14 - 0	6 - 0					
12 x 6	12	12	12	14 - 0	8 - 0					
12 x 8	12	12	12	14 - 0	10 - 0					
12 x 10	12	12	12	14 - 0	12 - 0					
12 x 12	12	12	12	14 - 0	14 - 0					

\* "T" MAY BE LARGER THAN SHOWN ON TABLE, PER ASTM C1577 SPECIFICATIONS.

