

STATE OF ILLINOIS  
DEPARTMENT OF TRANSPORTATION

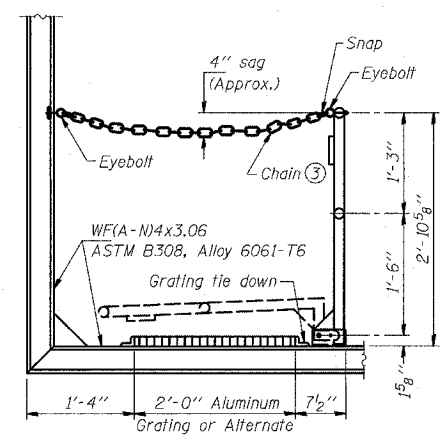

**SIDE ELEVATION**  
(Showing safety chain w/o sign)

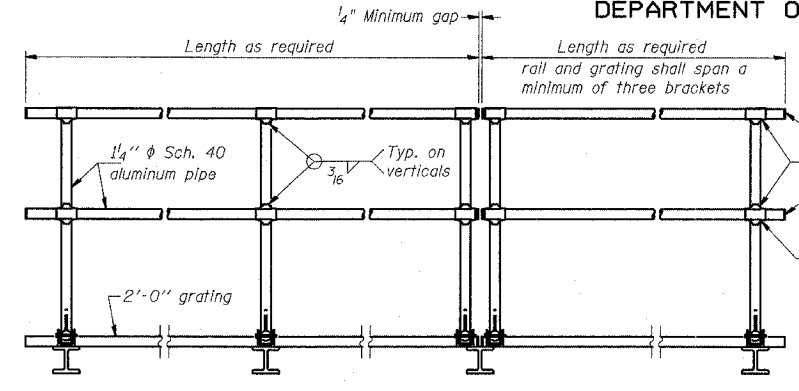

**FRONT ELEVATION**

① Install standard force-fit end caps or weld 3/8" end plates with 1/8" c.f.w. and grind smooth. (All rail ends)  
Fittings- ASTM B26, Alloy 356-T7

② Horizontal handrail member shall be continuous thru fitting. Provide 1/16" hole in fitting for 3/8" bolt. Field drill 1/16" hole in horizontal rail member. Provide locknut and two stainless steel washers for bolt. (Use 5/16" eyebolts in 1/16" holes on top rail at ends only.)

**HANDRAIL DETAILS**  
Handrail pipe shall be ASTM B241, Alloy 6063-T6 or Alloy 6061-T6.

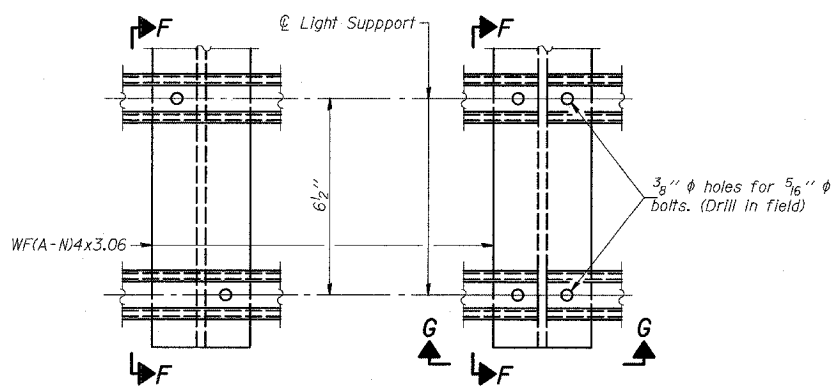

**DETAIL F**

**DETAIL G**

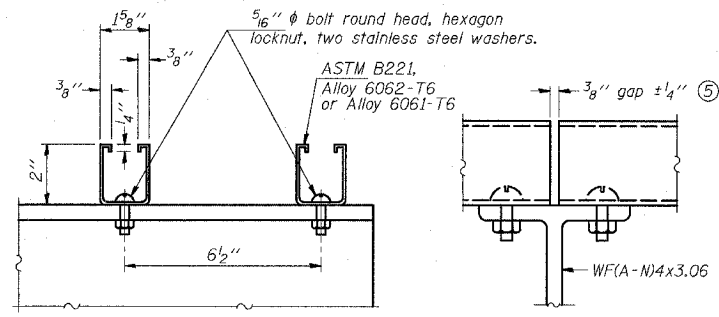

**SECTION F-F**

**SECTION G-G**

**LIGHTING FIXTURE MOUNTS (IF REQUIRED)**

⑤ Field cut ends of light support channels shall be free of burrs or hazardous projections and coated with zinc-rich primer or equivalent.

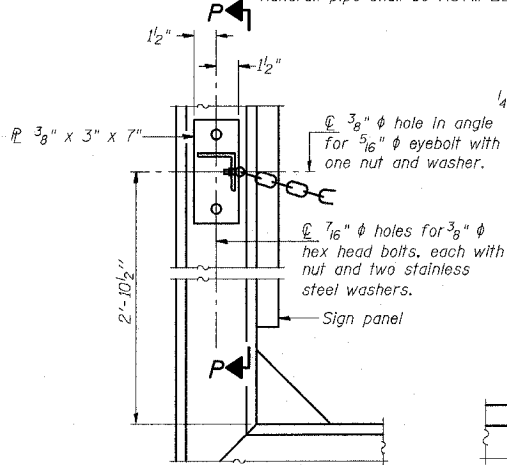

**ALTERNATE SAFETY CHAIN ATTACHMENT**  
(With Sign Present)

Items not shown same as "Side Elevation" of "Handrail Details"

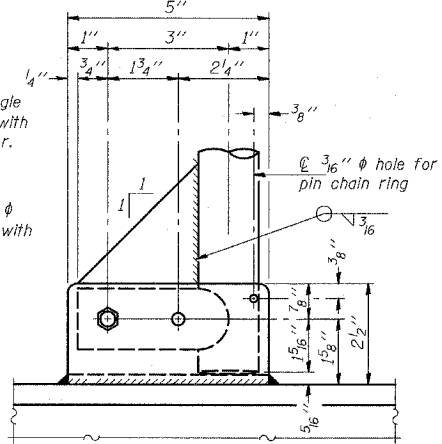

**SIDE ELEVATION**

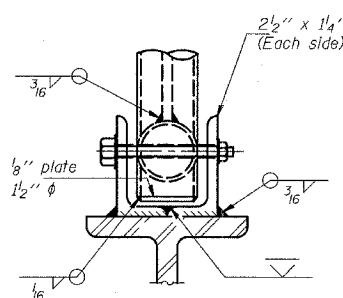

**FRONT ELEVATION**

See "ELEVATION" at right for dimensions.

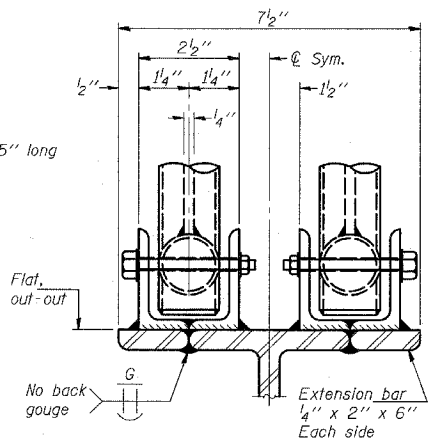

**ELEVATION AT HANDRAIL JOINT** ④

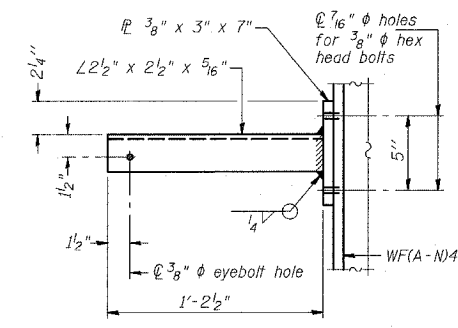

**SECTION P-P**

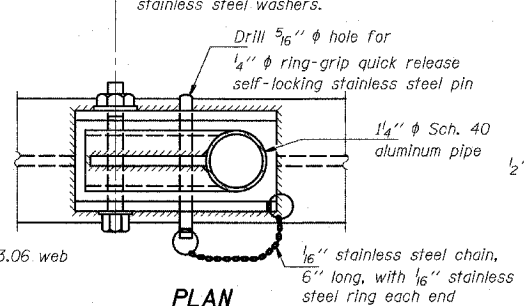

**PLAN DETAIL E HANDRAIL HINGE**

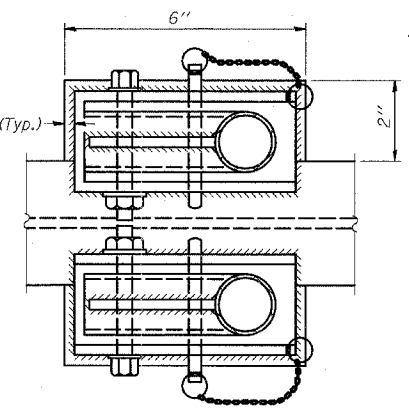

**PLAN AT HANDRAIL JOINT**

Details not shown same as "PLAN"

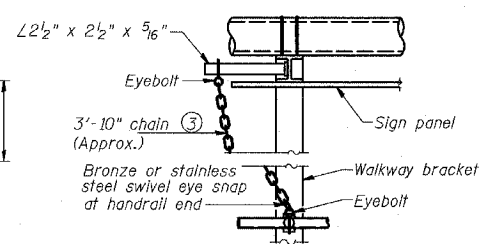

**ALTERNATE SAFETY CHAIN ATTACHMENT**

Details not shown similar to "Safety Chain" Details (Walkway omitted for clarity)

③ 3/16" galvanized steel chain, approximately 12 links per foot. Chain to be hot dip galvanized after manufacture and suitable for prolonged exterior exposure. Alternate materials may be substituted with the Engineer's approval.

④ Extrusions may be used in lieu of the details shown, with approval of the Engineer.

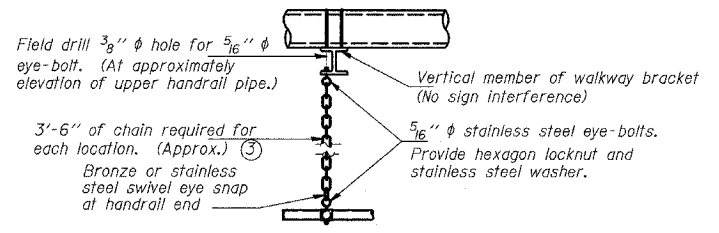

**SAFETY CHAIN**

One required for each end of each walkway.

DESIGNED	20
CHECKED	EXAMINED
DRAWN	PASSED
CHECKED	

NUMBER	REVISION	DATE

OS-A-11 11/1/2002

REVISIONS	
NAME	DATE