

STATE OF ILLINOIS
DEPARTMENT OF TRANSPORTATION

ROUTE NO.	SECTION	COUNTY	DATE	SHEET NO.	SHEET NO. 15
FAP 553	125 VBR-1	DEKALB	55	30	20 SHEETS
FED. ROAD DIST. NO. 7	ILLINOIS	FED. AID PROJECT-			

Contract #64858

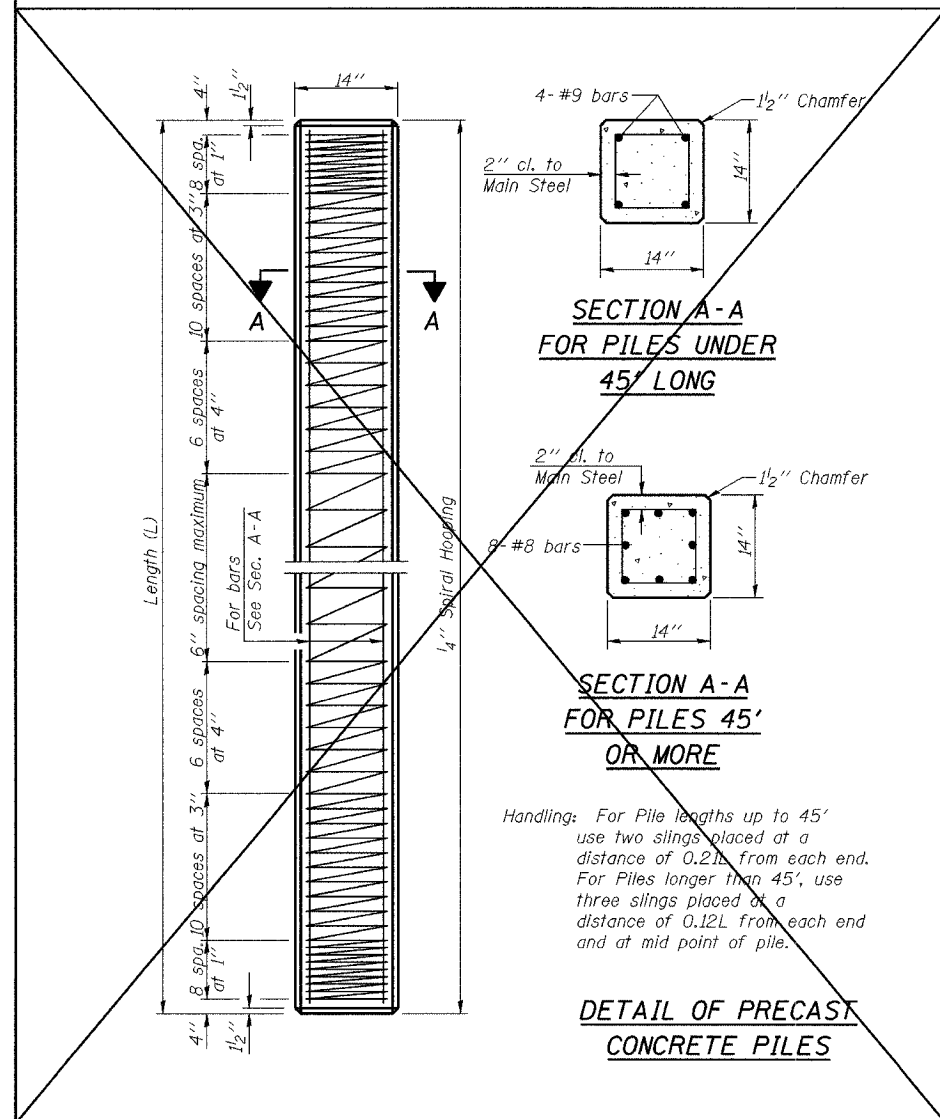

Notes:
Driving and bearing ends of pipe shall be cut square. The thickness of the shell shall be 0.250 inches with a tolerance of 5%. The shell shall be according to Article 1006.05(a) of the Standard Specifications.

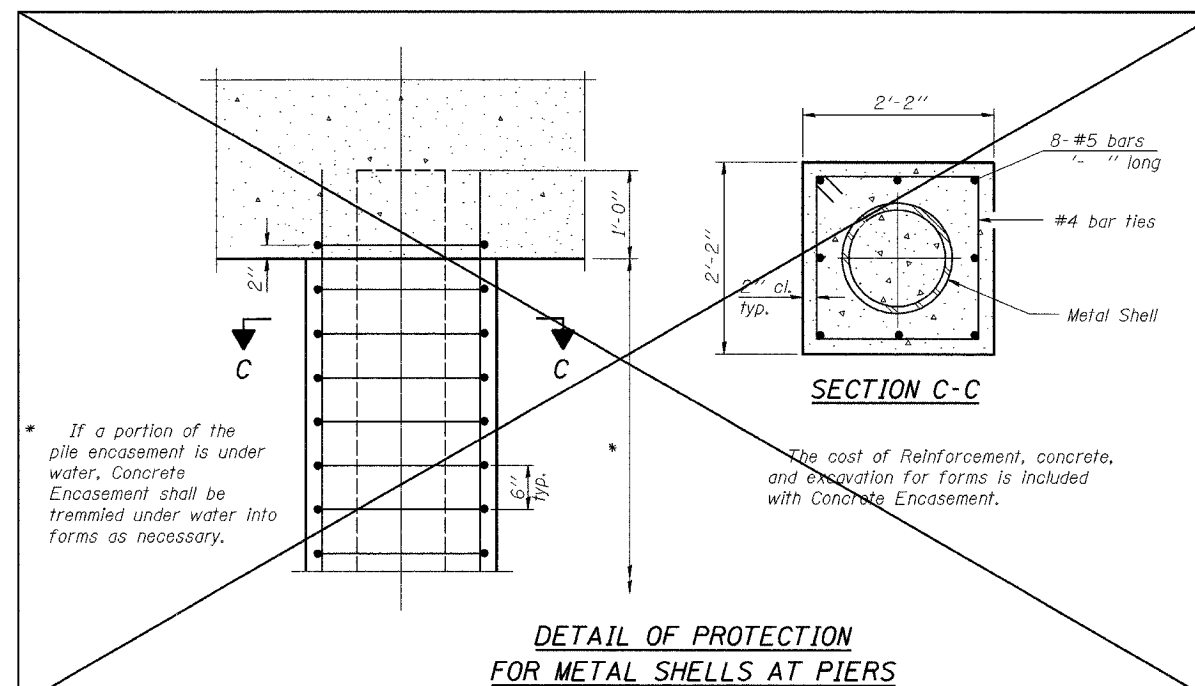
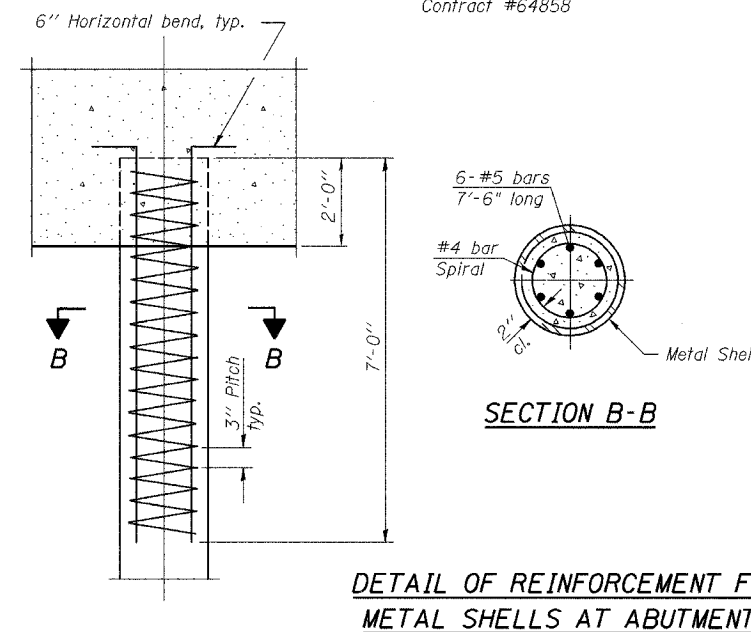
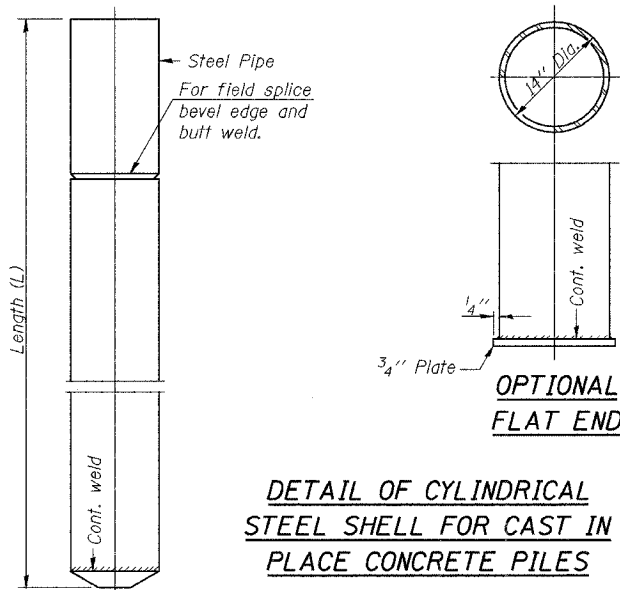

DESIGNED	JDA
CHECKED	JKC
DRAWN	ARR
CHECKED	JKC

X-PB

10-22-04

CONCRETE PILE DETAILS
IL RTE 72 OVER
IOWA CHICAGO & EASTERN RAILROAD
FAP ROUTE 553
SECTION 125VBR-1
DEKALB COUNTY
STA. 144+14.40
SN 019-0047