

FAI- RTE.	SECTION	COUNTY	TOTAL SHEETS	SHEET NO.
80	(32, 47-4)K	KENDALL/GRUNDY	243	181
FED. ROAD DIST. NO.		ILLINOIS FED. AID PROJECT		
CONTRACT NO. 66294				

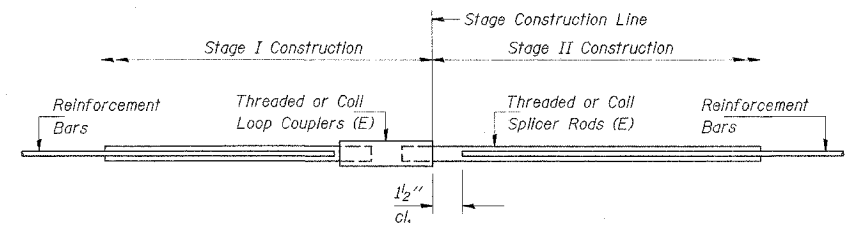

SPLICER DETAIL

Bar Size	No. Assemblies Required	Location
#4	0	11' x 4' Box Culvert
#4	0	8' x 3' Box Culvert
#4	0	8' x 5' Box Culvert
#4	0	7.5' x 2' Box Culvert
#5	140	11' x 4' Box Culvert
#5	60	8' x 3' Box Culvert
#5	0	8' x 5' Box Culvert
#5	0	7.5' x 2' Box Culvert
#6	75	11' x 4' Box Culvert
#6	30	8' x 3' Box Culvert
#6	0	8' x 5' Box Culvert
#6	0	7.5' x 2' Box Culvert

The diameter of this part is the same as the diameter of the bar spliced.

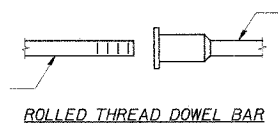

ROLLED THREAD DOWEL BAR



**** ONE PIECE**

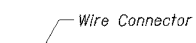

WELDED SECTIONS

** Heavy Hex Nuts conforming to ASTM A 563, Grade C, D or DH may be used.

NOTES

Bar splicer assemblies shall be of an approved type and shall develop in tension at least 125 percent of the yield strength of the lapped reinforcement bars.
 Splicer rods shall be of minimum 60 ksi yield strength, threaded or coiled full length.
 All reinforcement bars shall be lapped and tied to the splicer rods or dowel bars.
 Bar splicer assemblies shall be epoxy coated according to the requirements for reinforcement bars.
 Other systems of similar design may be submitted to the Engineer for approval. Approval shall be based on certified test results from an approved testing laboratory that the proposed bar splicer assembly satisfies the following requirements:

- Minimum Capacity = $1.25 \times f_y \times A_f$
(Tension in kips)
- Minimum *Pull-out Strength = $1.25 \times f_s \text{ allow} \times A_f$
(Tension in kips)

Where f_y = Yield strength of lapped reinforcement bars in ksi.
 $f_s \text{ allow}$ = Allowable tensile stress in lapped reinforcement bars in ksi (Service Load)
 A_f = Tensile stress area of lapped reinforcement bars.
 * = 28 day concrete

BAR SPLICER ASSEMBLIES			
Bar Size to be Spliced	Splicer Rod or Dowel Bar Length	Strength Requirements	
		Min. Capacity kips - tension	Min. Pull-Out Strength kips - tension
#5	2'-0"	23.0	9.2
#6	2'-7"	33.1	13.3
#7	3'-5"	45.1	18.0
#8	4'-6"	58.9	23.6

Bar splicer assemblies shall be according to Section 508 of the Standard Specifications, except as noted. The furnishing and installation of bar splicer assemblies will be measured and paid for at the contract unit price each for "BAR SPLICERS."

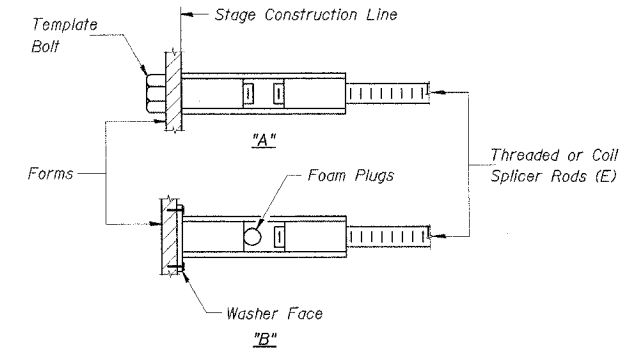

INSTALLATION AND SETTING METHODS

"A" : Set bar splicer assembly by means of a template bolt.
 "B" : Set bar splicer assembly by nailing to wood forms or cementing to steel forms.
 (E) : Indicates epoxy coating.

REVISIONS	
NAME	DATE

ILLINOIS DEPARTMENT OF TRANSPORTATION
 FAI ROUTE 80
 (I-80 AT MINOOKA INTERCHANGE)

BAR SPLICER DETAILS

SCALE: NONE
 DATE: 2/10/06
 DRAWN BY: M. Tryon
 CHECKED BY: A. Yargicoglu