

STATE OF ILLINOIS
DEPARTMENT OF TRANSPORTATION

ROUTE NO.	SECTION	COUNTY	TOTAL SHEETS	SHEET NO.
		Tazewell	9	7
FED. ROAD DIST. NO. 7	ILLINOIS	FED. AID PROJECT		

SHEET NO. 2
2 SHEETS

Contract Number: 68585

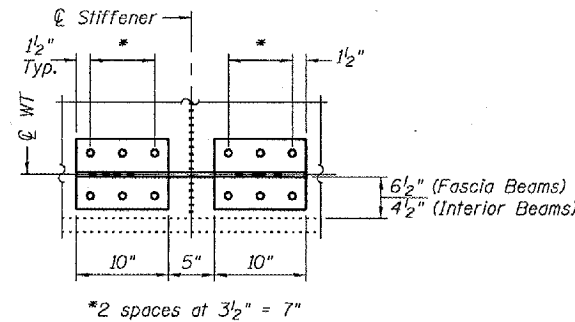
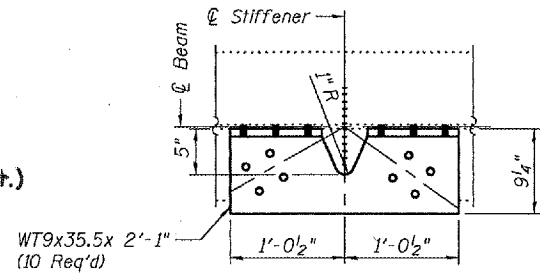
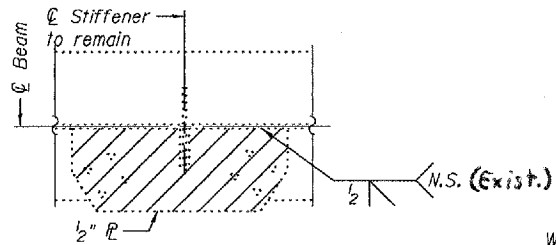

REPAIR A

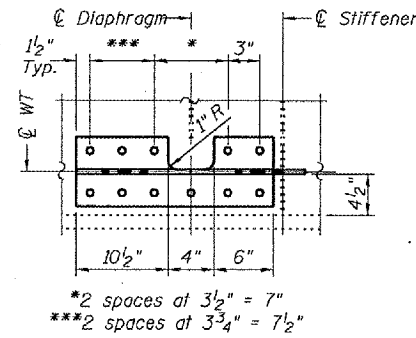
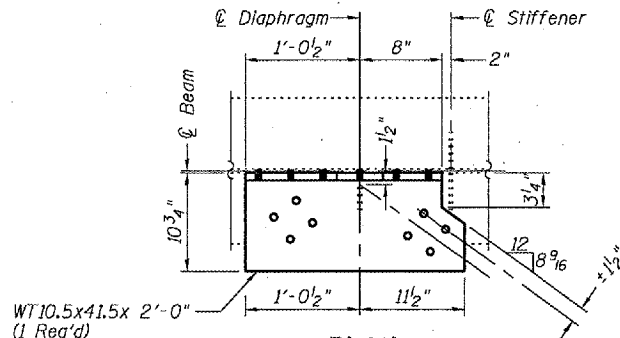
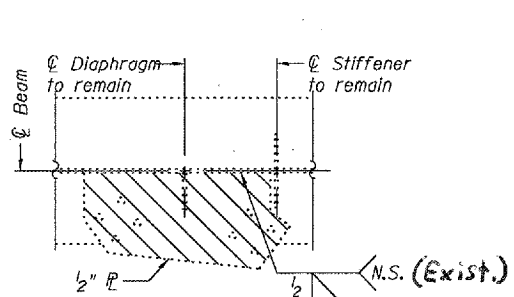
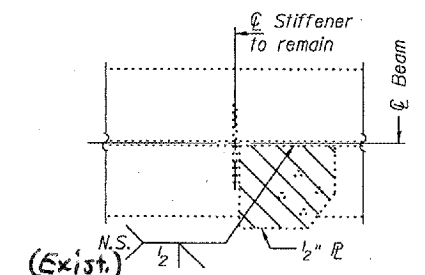

REPAIR B

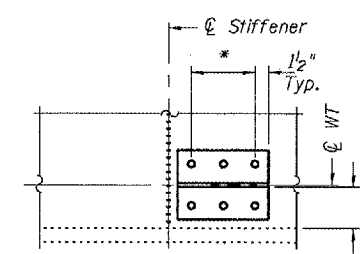
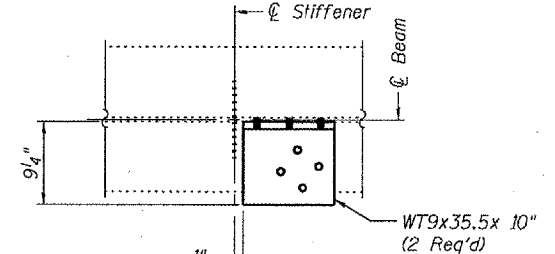

REPAIR D

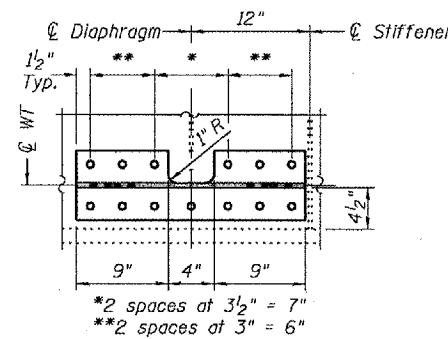
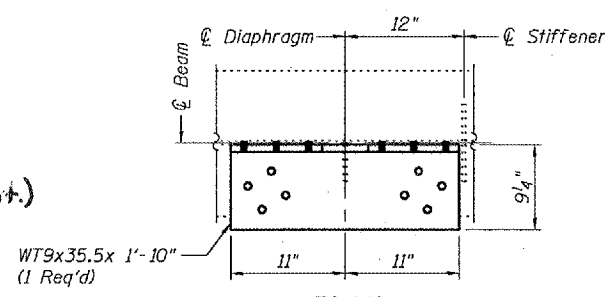
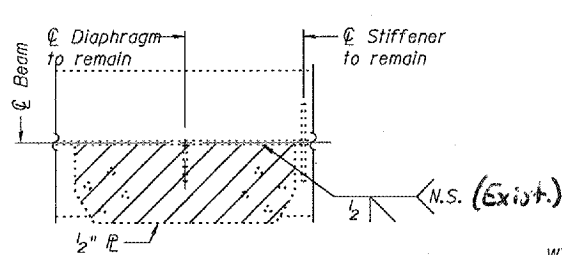

REPAIR C

****Field drill holes in existing girder web using holes in WT gusset P's as a template.

See Procedure for Hoan Repair Details on Sheet 1 of 2.

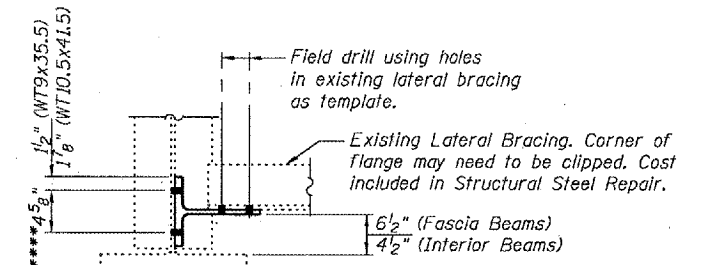

REPAIR DETAILS
I-155 (S.B.) / MACKINAW RIVER
TAZEWELL COUNTY
SN 090-0092

DESIGNED	A.T.H.
CHECKED	P.S.J.
DRAWN	Drew Christopher
CHECKED	A.T.H. P.S.J.

March 1, 2006	
EXAMINED	John A. Morris ENGINEER OF STRUCTURAL SERVICES
PASSED	Ralph E. Anderson ENGINEER OF BRIDGES AND STRUCTURES