

ROUTE NO.	SECTION	COUNTY	TOTAL SHEETS	SHEET NO.
C.H. 8	05-00085-00-BR	MARSHALL	13	5
		ILLINOIS	PROJ. NO. BR05-123(2D)	

CONTRACT NO. 89397

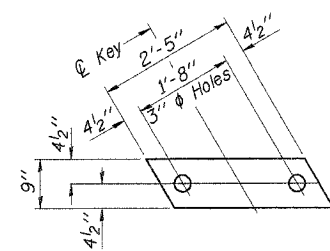

FABRIC BEARING PAD
(Interior)
(12 Req'd.)

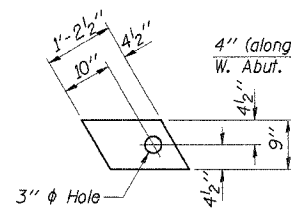

FABRIC BEARING PAD
(Exterior)
(4 Req'd.)

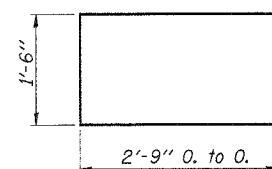

BAR U₁

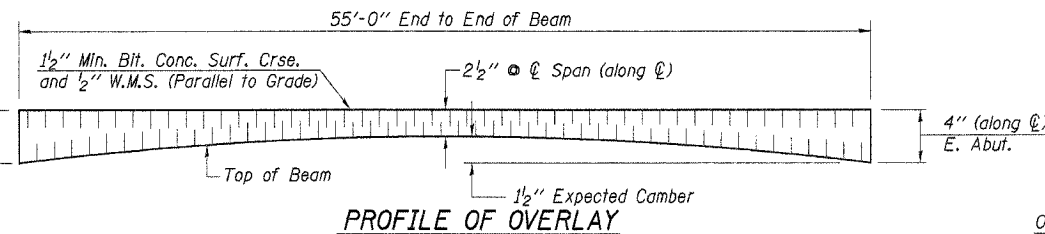

PROFILE OF OVERLAY

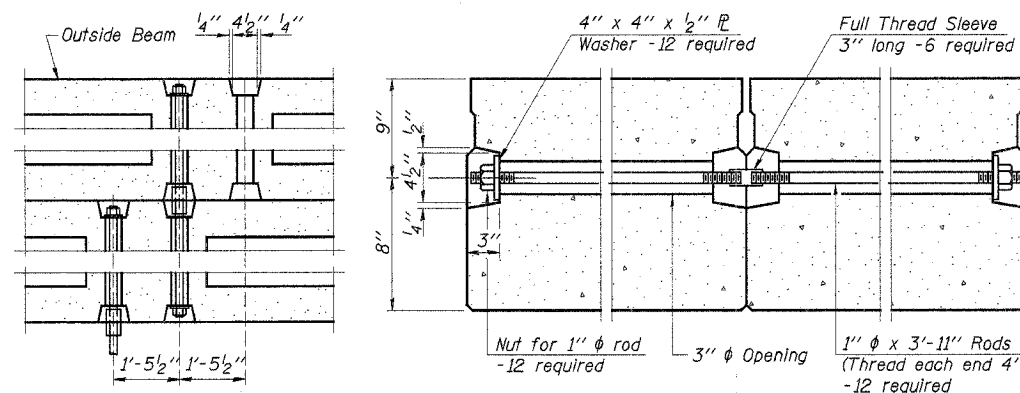

TYPICAL TRANSVERSE TIE ASSEMBLY

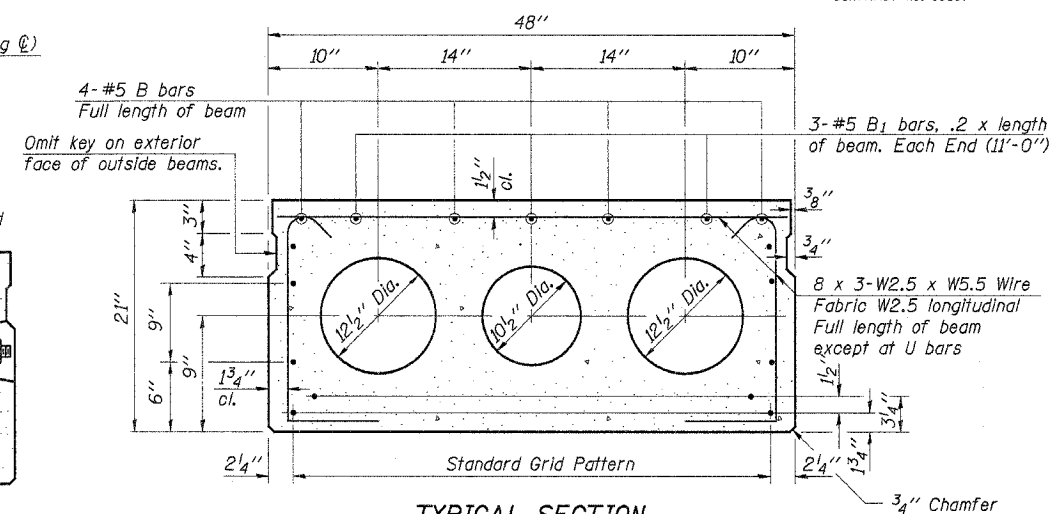

TYPICAL SECTION

22-1/2" ϕ Strands, Each Strand Stressed to 30,900 Lbs. Note:
14-Strands 1 3/4" up, 4-Strands 3/4" up, 2-Strands 6" up, Place strands symmetrically
2-Strands 15" up about ϕ of beam.

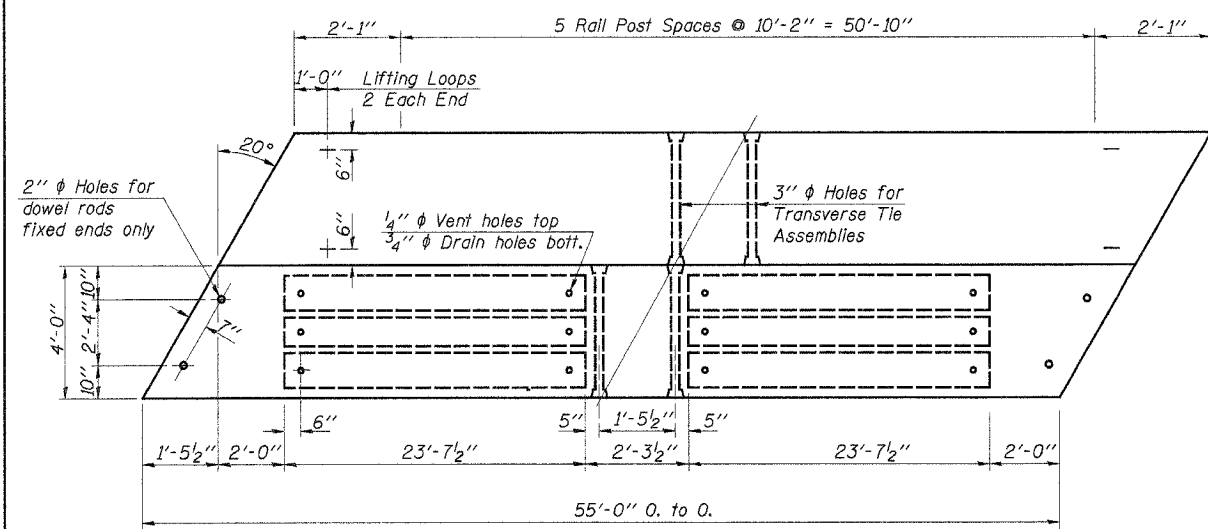

PLAN

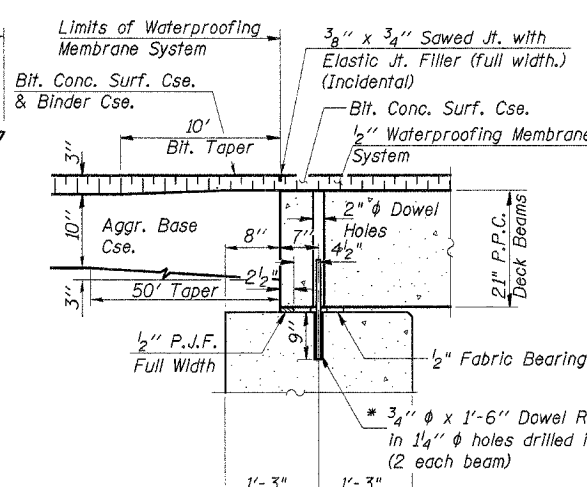

SEC. THRU ABUT.

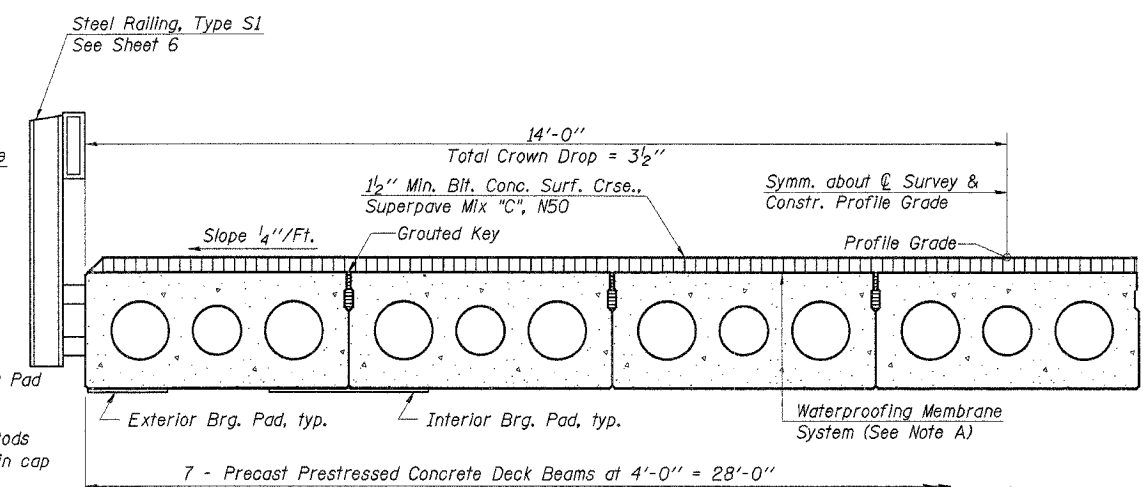

HALF CROSS SECTION

Note A:
The top surface of the beams shall be finished in accordance with Article 504.06 of the Standard Specifications except that the surface shall not be roughed by brooming. The finished surface shall be free of depressions or high spots with sharp corners and the top edge of keys shall be roughed or chamfered a min. of 1/4".

* Dowel Rods to be grouted after beams are in place and allowed to cure (Min. 24 hrs.) prior to grouting the shear keys.

NOTES

Prestressing steel shall be uncoated high strength, low relaxation 7-wire strand, Grade 270. The nominal diameter shall be 1/2" and the nominal cross-sectional area shall be 0.153 sq. in. Lifting loops shall be 3-1/2" ϕ -270 ksi strands, as shown. The 1" ϕ rods in the transverse tie assembly shall be tightened to a snug fit and the threads set. Pockets that receive transverse tie bar on outside shall be filled with grout after transverse tie assembly is in place. Non prestressing steel shall conform to AASHTO M-31, M-42 or M-53 Grade 60. The bearing seat surfaces shall be adjusted by shimming to assure firm and even bearing. Two 1/2" fabric adjusting shims of the dimensions of the Exterior Bearing Pad shall be provided for each bearing. (32 Required) Keyway surfaces shall be cleaned to remove form oil or other bond breaking material prior to shipment of the beams. Cleaning shall be done by sandblasting the keyway areas between top of the beam and the bottom edge of the key. Required Release Strength, f'ci, shall be 4,000 p.s.i. See Special Provisions for review and distribution of shop drawings. Rail post anchor devices shall be cast into outside beam as elsewhere specified.

BILL OF MATERIAL

Item	Unit	Quantity
Precast Prestressed Concrete Deck Beams (21" Depth)	Sq. Ft.	1540
Bit. Conc. Surf. Crse., Mix "C", N50	Ton	20
Waterproofing Membrane System	Sq. Yd.	172
P.C. Mortar Fairing Course	Foot	165

Estimated Total Weight (One Beam) = 42,920 Pounds

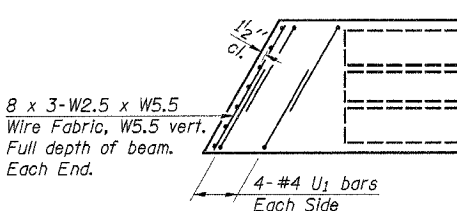

END PLAN

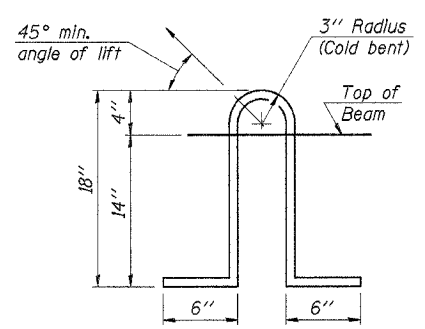

LIFTING LOOP DETAIL

DESIGNED	SFM
CHECKED	FJS
DRAWN	SAP & JPS
CHECKED	SFM

PD-4-L 9-1-03

SUPERSTRUCTURE

**COUNTY HIGHWAY 8
SECTION 05-00085-00-BR
MARSHALL COUNTY
STATION 15+04**

4440 ASH GROVE SPRINGFIELD, IL 62711 (217) 793-8800 casinc@amvid.com	OZYURT AND STONE, INC. CONSULTING ENGINEERS	JOB NO.: 0413 FILE: 17x49L.DGN DATE: 01/31/06
---	---	---