

ROUTE NO. C.H. 5 FAS 639	SECTION 03-0087 -00-BR	COUNTY CHRISTIAN	TOTAL SHEETS 12	SHEET NO. 5
--------------------------------	------------------------------	---------------------	--------------------	----------------

ILLINOIS
CONTRACT NO. 93402

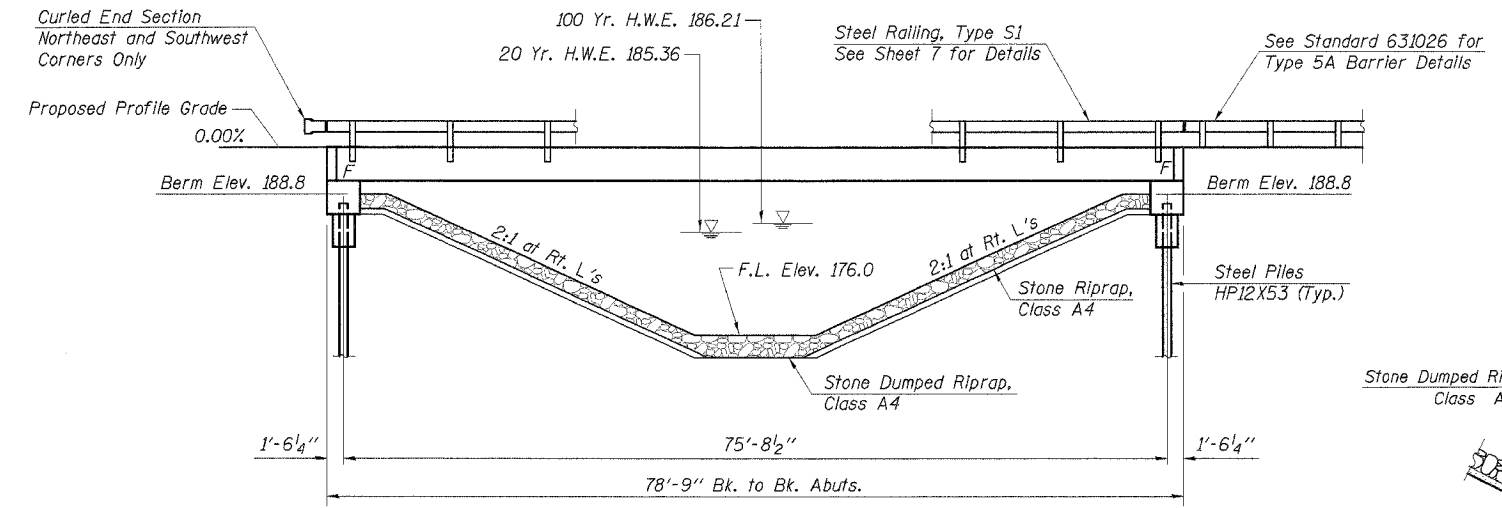

ELEVATION

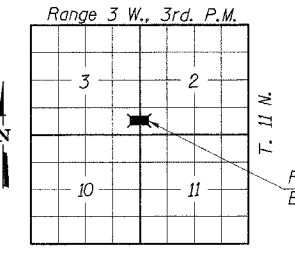

LOCATION PLAN

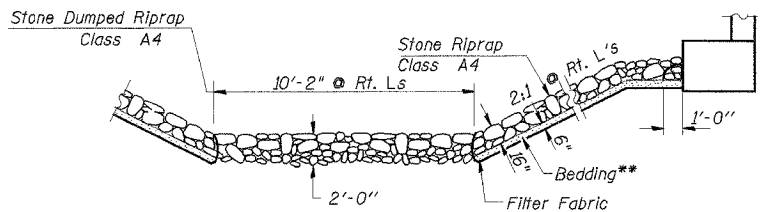

RIPRAP PLACEMENT

**Included in the cost of Riprap

GENERAL NOTES

See Special Provisions for Boring data.

Reinforcement bars shall conform to the requirements of AASHTO M-31, M-42 or M-53, Grade 60.

The Contractor shall drive one steel test pile in a permanent location at each abutment as directed by the Engineer, before ordering the remainder of piles.

Layout of slope protection system may be varied in the field to suit ground conditions as directed by the Engineer.

Structure excavation will not be paid for as a separate item but shall be considered as included in the contract unit price for the class of concrete involved.

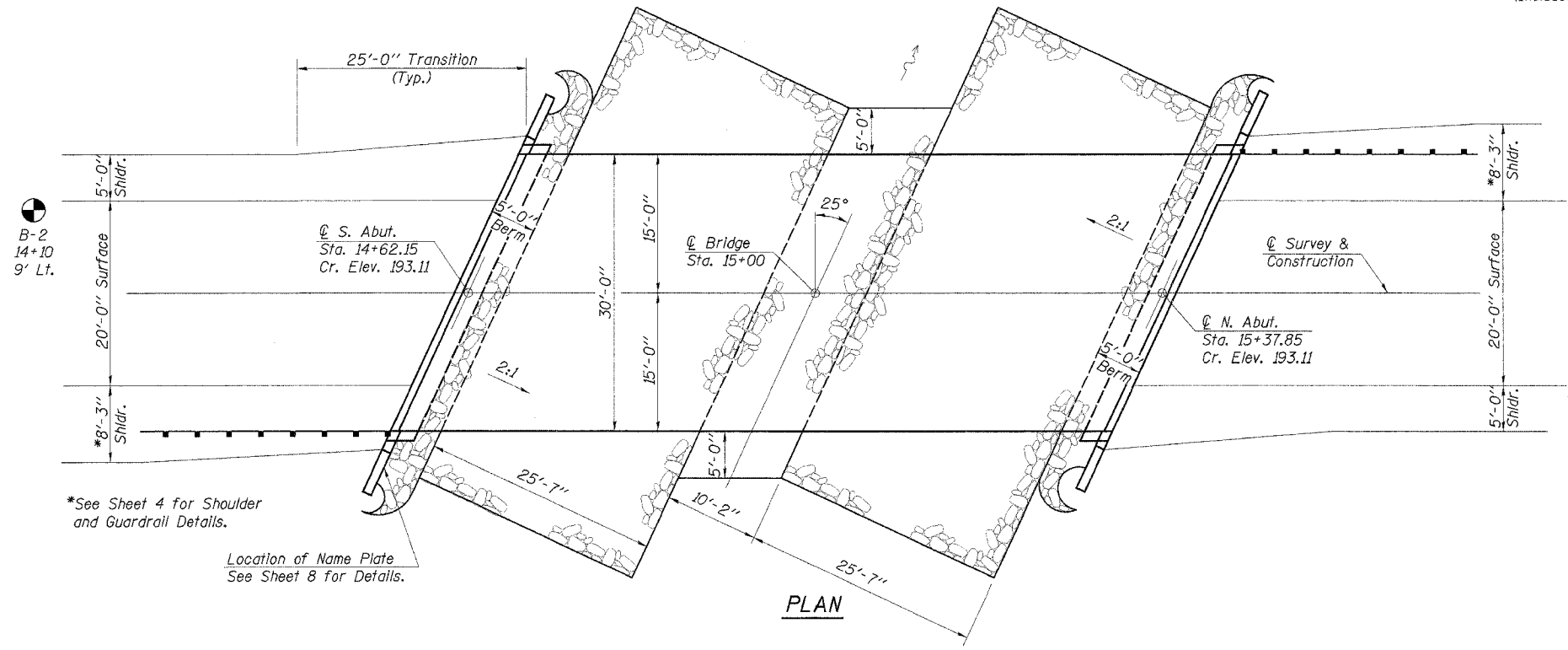

PLAN

B-2
14+10
9' Lt.

B-1
16+00
14' Rt.

*See Sheet 4 for Shoulder and Guardrail Details.

Location of Name Plate See Sheet 8 for Details.

MILLER BRANCH
BUILT 200_ BY
CHRISTIAN COUNTY
SEC. 03-0087-00-BR
F.A.S. RTE. 639 (C.H. 5)
F.A. PROJ. BRS 639(104)
STR. NO. 011-3401 LOADING HS20

LETTERING FOR NAME PLATE
See Std. 515001

TOTAL BILL OF MATERIAL

ITEM	UNIT	SUPER	SUB	TOTAL
Precast Prestressed Concrete Deck Beams (33" Depth)	Sq. Ft.	2310		2310
Concrete Structures	Cu. Yd.	32.2		32.2
Reinforcement Bars	Pound	3480		3480
Steel Railing, Type S1	Foot	154		154
Name Plates	Each		1	1
Steel Piles HP12x53	Foot		420	420
Test Pile Steel HP12x53	Each		2	2
Stone Riprap, Class A4	Ton		282	282
Filter Fabric For Use with Riprap	Sq. Yd.		385	385
Concrete Encasement	Cu. Yd.		5.6	5.6
Bit. Conc. Surf. Crse., Superpave, Mix C, N50	Ton	30		30
Portland Cement Mortar Fairing Course	Foot	200		200
Waterproofing Membrane System	Sq. Yd.	257		257
Stone Dumped Riprap, Class A4	Ton		55	55

DESIGN STRESSES

$f_c = 5,000$ p.s.i. (Prestressed Beams)
 $f_{ti} = 4,000$ p.s.i. (Prestressed Beams)
 $f_c = 1,400$ p.s.i. (Concrete)
 $f_s = 270,000$ p.s.i. (Prestressed Strands)
 $f_{si} = 201,960$ p.s.i. (Prestressed Strands)
 $f_s = 24,000$ p.s.i. (Reinf. Bars -- Field Units)
 $f_y = 60,000$ p.s.i. (Reinf. Bars -- Field Units)
 $n = 9$ (Concrete)

LOADING HS20-44
 Design Specifications: 2002 AASHTO
 25#/Sq. Ft. Included in dead load for future wearing surface.

WATERWAY INFORMATION

Drainage Area	6.68 Sq. Mi.
Existing Opening (20 Yr.)	228 Sq. Ft.
Required Opening (20 Yr.)	264 Sq. Ft.
Proposed Opening (20 Yr.)	264 Sq. Ft.
Design Discharge (20 Yr.)	1045 C.F.S.
Created Head (20 Yr.)	0.22 Ft.
100 Year Discharge	1568 C.F.S.
100 Yr. Created Head	0.42 Ft.

DESIGNED	FJS
CHECKED	SFM
DRAWN	SAP & KTR
CHECKED	SFM

"I certify that to the best of my knowledge, information and belief, this bridge design is structurally adequate for the design loading shown on the plans. The design is an economical one for the style of structure and complies with requirements of the current 'AASHTO Standard Specifications for Highway Bridges'."

Fred J. Stone, Jr. (11-29-05)
 ILLINOIS STRUCTURAL NO. 2934 (Expires 11/30/06)



GENERAL PLAN & ELEVATION

COUNTY HIGHWAY 5
 SECTION 03-0087-00-BR
 CHRISTIAN COUNTY
 STATION 15+00

4440 ASH GROVE SPRINGFIELD, IL 62707 (217) 793-8600 oasinc@famvid.com	OZYURT AND STONE, INC. CONSULTING ENGINEERS	JOB NO.: 0305 FILE: GPE.DGN DATE: 03-15-04
--	---	--