

MID-SPAN STEEL FRAME SUPPORTS (4 required)
(Looking South)

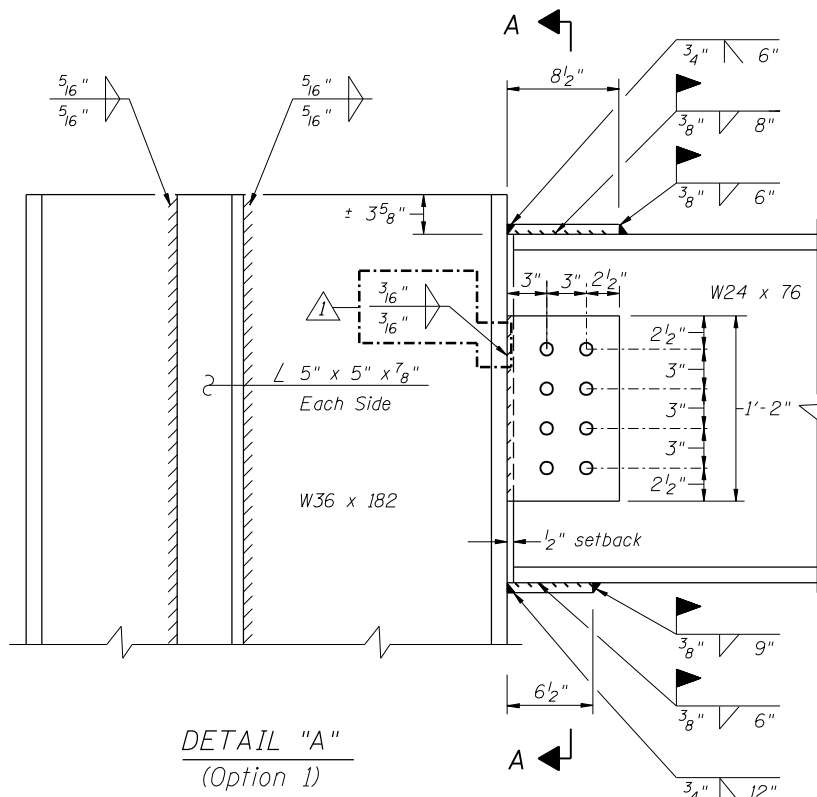

DETAIL "A"
(Option 1)

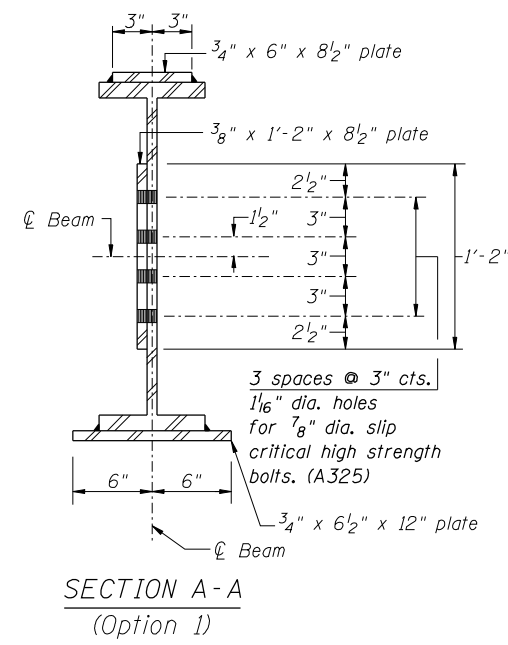

SECTION A-A
(Option 1)

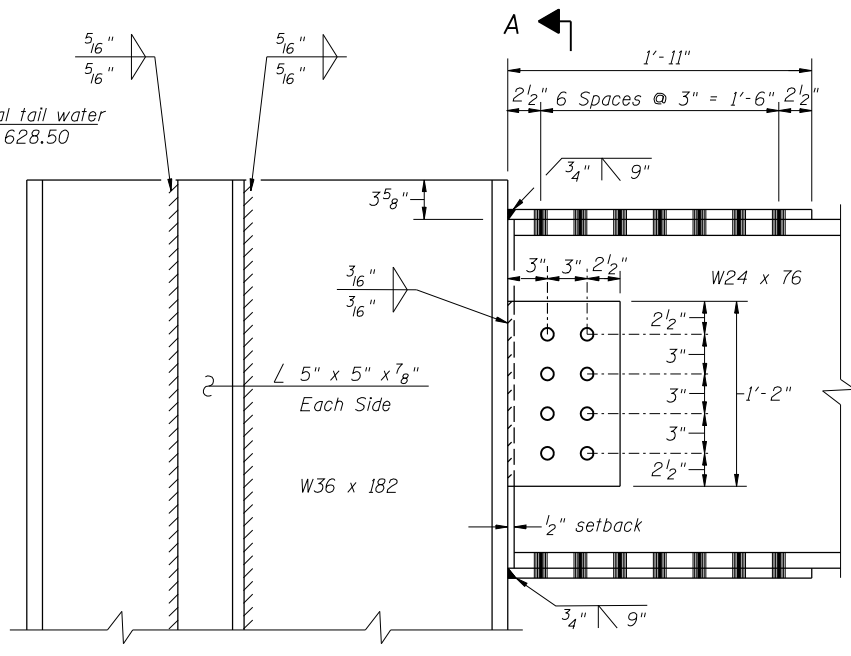

DETAIL "A"
(Option 2)

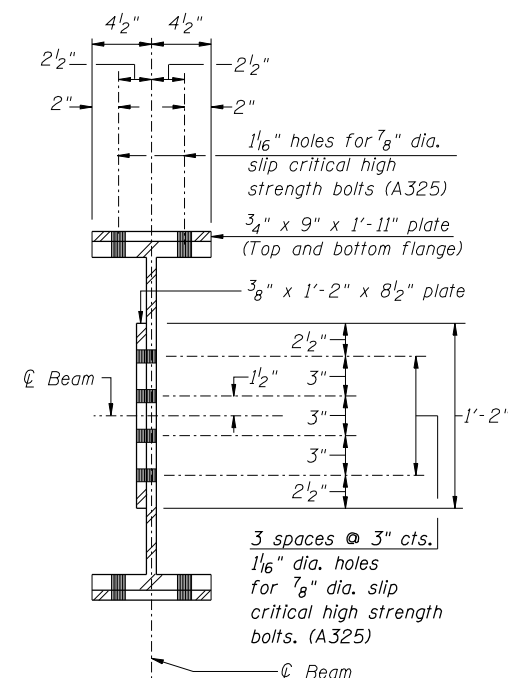

SECTION A-A
(Option 2)

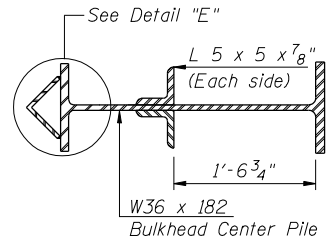

SECTION B-B

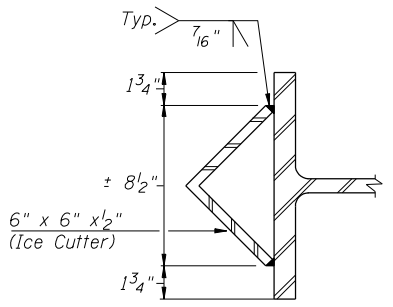

DETAIL "E"

Notes:

1. The Contractor shall have the option of using either Option 1 or Option 2 in Detail "A".
2. The calculated weight of structural steel which is based upon the use of Option 2 = 43,710 pounds.
3. All structural steel shall be AASHTO M270, Grade 50W.
4. All structural steel shall conform to the supplemental requirements for Notch Toughness Zone 2.
5. The cofferdam shall be designed and constructed according to the requirements of Article 502.06 of the Standard Specifications.
6. All costs to dewater the cofferdam shall be considered as included with "Cofferdams".

Revised 4/17/2006, TMM