

ELEVATION AT MID-SPAN SUPPORT

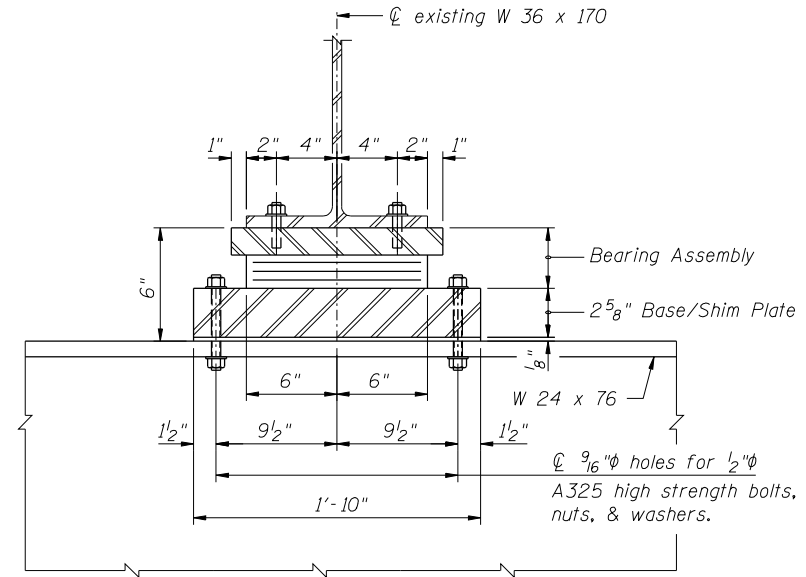

SECTION A-A

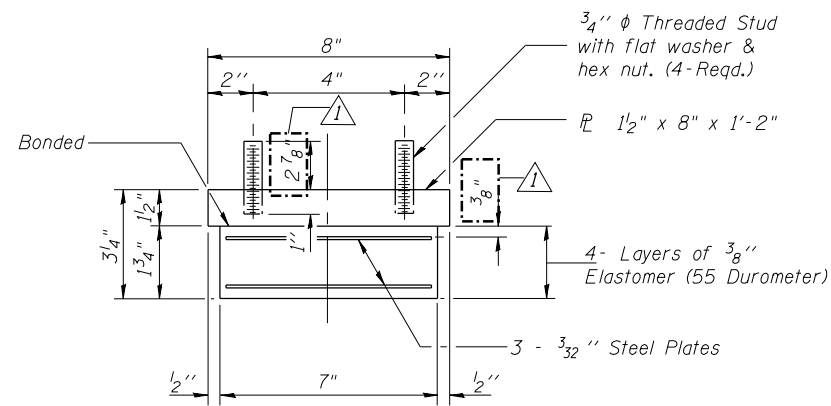

BEARING ASSEMBLY

TYPE I ELASTOMERIC EXPANSION BEARING DETAILS

Notes:

All steel plates shall conform to AASHTO M270 Grade 50W.

Calculated weight of structural steel (Plates, bolts, nuts and washers) is 1,220 pounds.

BILL OF MATERIAL

Item	Unit	Quantity
Elastomeric Bearing Assembly, Type I	Each	8

DESIGNED BY TMM CHECKED BY RLP  
 DRAWN BY JUF CHECKED BY TMM  
 \$FILES  
 \$TIMES  
 \$DATES

Revised 4/17/2006, TMM