

SEAL THE OPEN ENDS OF THE UNDERGROUND DUCT AFTER REMOVAL OF THE TRANSCLOSURE. COST TO BE INCIDENTAL TO THE CONTRACT.

REMOVE EXISTING 4-#12-12/C CABLES FROM UNDERGROUND DUCT BETWEEN TERMINAL BUILDING AND TRANSCLOSURE, SEAL THE OPEN ENDS OF THE DUCT THAT ARE UNDERGROUND. COST TO BE INCIDENTAL TO THE CONTRACT.

LOCATE EXISTING POWER FEED CABLES FOR THE BEACON AND APRON POLE LIGHTS THAT EXIT THE TRANSCLOSURE. INSTALL SPLICE CAN TO CONNECT THE EXISTING CABLES TO NEW CABLES FROM THE NEW ELECTRICAL VAULT. INSTALL NEW CABLES SIZED TO MATCH THE EXISTING CABLES. TO BE PAID FOR PER LIN. FT. FOR #8 5KV, T.Y. C. 1/C UG CABLE & FOR CABLE TRENCH.

REMOVE EXISTING METAL TRANSCLOSURE HOUSINGS AND CONCRETE BASE AS A WHOLE UNIT OF REMOVAL TO BE PAID FOR PER LUMP SUM FOR REMOVE ELECTRICAL TRANSCLOSURE.

EXISTING AIRFIELD LIGHTING CABLES

EXISTING SANITARY SEWER

TERMINAL BUILDING

MAINTENANCE BUILDING

FBO BUILDING

BEACON

SWK EL 761.38

SWK EL 761.76

SWK EL 761.32

PROPOSED ELECTRICAL VAULT BUILDING (21'-4" x 17'-4") FLOOR ELEV. 761.80

PROPOSED 5" P.C. CONCRETE SIDEWALK (8'-0" x 12'-0")

BITUMINOUS PAVEMENT

CONC. PVMT.

EXISTING STORM SEWER

DISCONNECT THE CABLES FROM THE EXISTING DISCONNECT SWITCH IN THE EXISTING TERMINAL BUILDING THAT FEED POWER TO THE NORTHERLY ELECTRICAL TRANSCLOSURE UNIT. TAPE THE ENDS OF THE CABLES AND TAG WITH NOTE TO INDICATE THE CABLES ARE ABANDONED.

B.M. N.E. FLANGE BOLT ON FIRE HYDRANT ELEV. 758.77

FHC

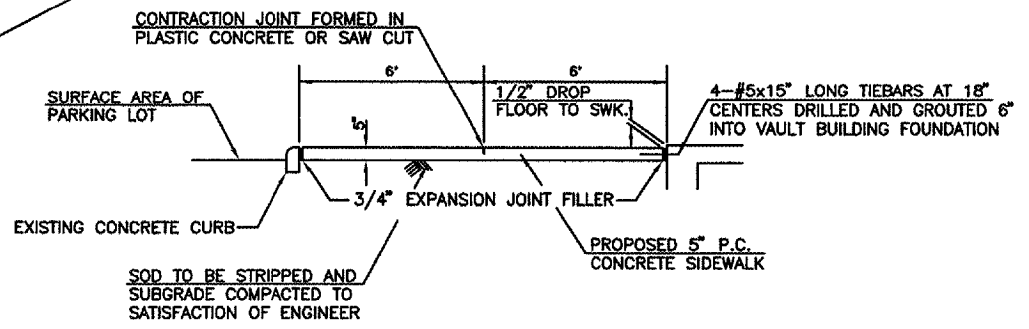

TYPICAL SECTION OF 5" PCC SIDEWALK

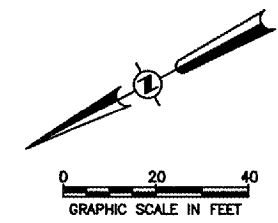

GALESBURG MUNICIPAL AIRPORT GALESBURG, ILLINOIS	
ELECTRICAL VAULT SITE PLAN	
HUTCHISON ENGINEERING, INC. JACKSONVILLE, ILLINOIS	
DRAWN BY: T.J.D. DATE: MARCH, 2006	ILL. PROJ. NO. GBG-3433 AP PROJ. NO. 3-17-0047-BB