

THE EXISTING MAST ARM FOUNDATIONS LOCATED WITHIN THE ISLANDS WILL BE MODIFIED TO ACCOMODATE THE PROPOSED TRAFFIC SIGNAL POSTS. THIS WORK WILL BE PAID FOR AS "MODIFY EXISTING CONCRETE FOUNDATION"

THE EXISTING CONCRETE HANDHOLES LOCATED WITHIN THE ISLANDS WILL BE REBUILT AND USED IN THE PROPOSED TRAFFIC SIGNAL INSTALLATION. THIS WORK WILL BE PAID FOR AS "REBUILD EXISTING HANDHOLE"

THE CONTRACTOR SHALL COUPLE THE PROPOSED CONDUITS TO THE EXISTING CONDUITS AS NEEDED WITHIN THE ISLANDS TO RESTORE CONTINUITY.

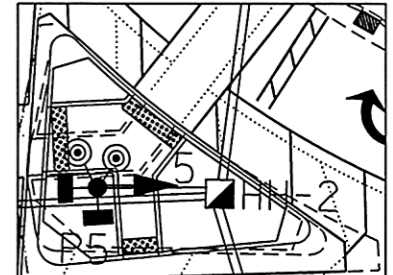

NE ISLAND DETAIL

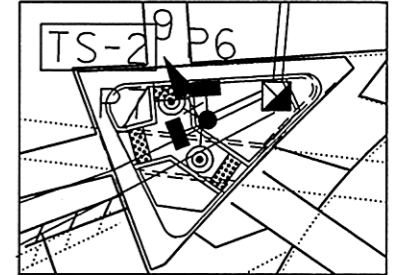

SE ISLAND DETAIL

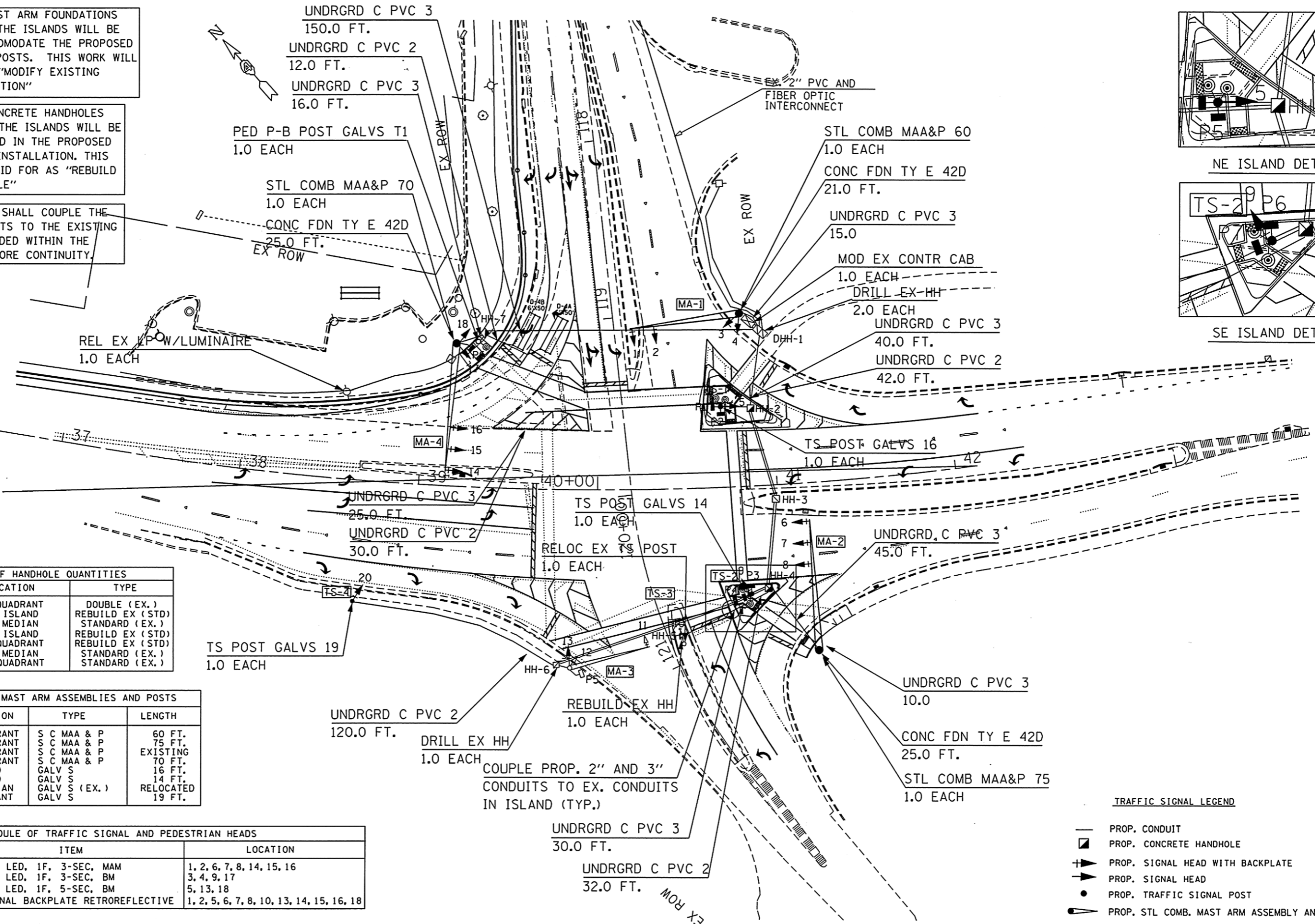

SCHEDULE OF HANDHOLE QUANTITIES		
REF.	LOCATION	TYPE
DHH-1	SE QUADRANT	DOUBLE (EX.)
HH-2	SE ISLAND	REBUILD EX (STD)
HH-3	S MEDIAN	STANDARD (EX.)
HH-4	SW ISLAND	REBUILD EX (STD)
HH-5	SW QUADRANT	REBUILD EX (STD)
HH-6	W MEDIAN	STANDARD (EX.)
HH-7	NE QUADRANT	STANDARD (EX.)

SCHEDULE OF MAST ARM ASSEMBLIES AND POSTS			
REF.	LOCATION	TYPE	LENGTH
MA-1	SE QUADRANT	S C MAA & P	60 FT.
MA-2	SW QUADRANT	S C MAA & P	75 FT.
MA-3	NW QUADRANT	S C MAA & P	EXISTING
MA-4	NE QUADRANT	S C MAA & P	70 FT.
TS-1	NE ISLAND	GALV S	16 FT.
TS-2	SE ISLAND	GALV S	14 FT.
TS-3	WEST MEDIAN	GALV S (EX.)	RELOCATED
TS-4	SW QUADRANT	GALV S	19 FT.

SCHEDULE OF TRAFFIC SIGNAL AND PEDESTRIAN HEADS			
QTY	UNIT	ITEM	LOCATION
8.0	EA.	SH, LED, 1F, 3-SEC, MAM	1, 2, 6, 7, 8, 14, 15, 16
4.0	EA.	SH, LED, 1F, 3-SEC, BM	3, 4, 9, 17
3.0	EA.	SH, LED, 1F, 5-SEC, BM	5, 13, 18
12.0	EA.	SIGNAL BACKPLATE RETROREFLECTIVE	1, 2, 5, 6, 7, 8, 10, 13, 14, 15, 16, 18

- TRAFFIC SIGNAL LEGEND**
- PROP. CONDUIT
 - ◻ PROP. CONCRETE HANDHOLE
 - + PROP. SIGNAL HEAD WITH BACKPLATE
 - ▶ PROP. SIGNAL HEAD
 - PROP. TRAFFIC SIGNAL POST
 - ◁ PROP. STL COMB. MAST ARM ASSEMBLY AND POLE

REV SHEET 4-12-17 BM

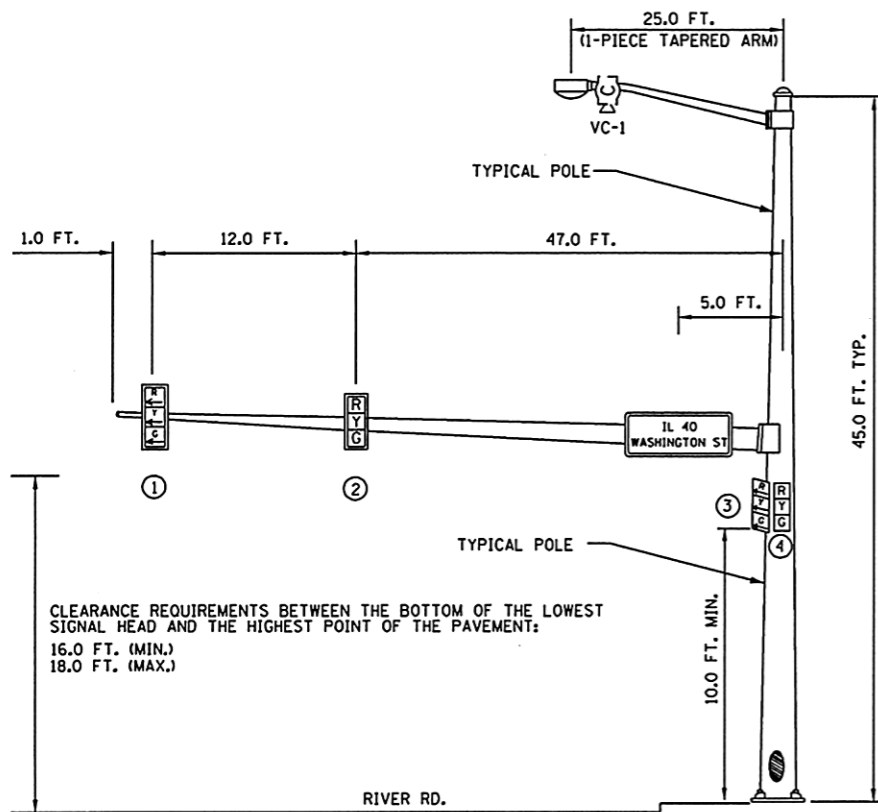

NORTHBOUND TRAFFIC SIGNAL

NORTHEAST CORNER OF IL 40 & RIVER RD/TRACTOR DR.

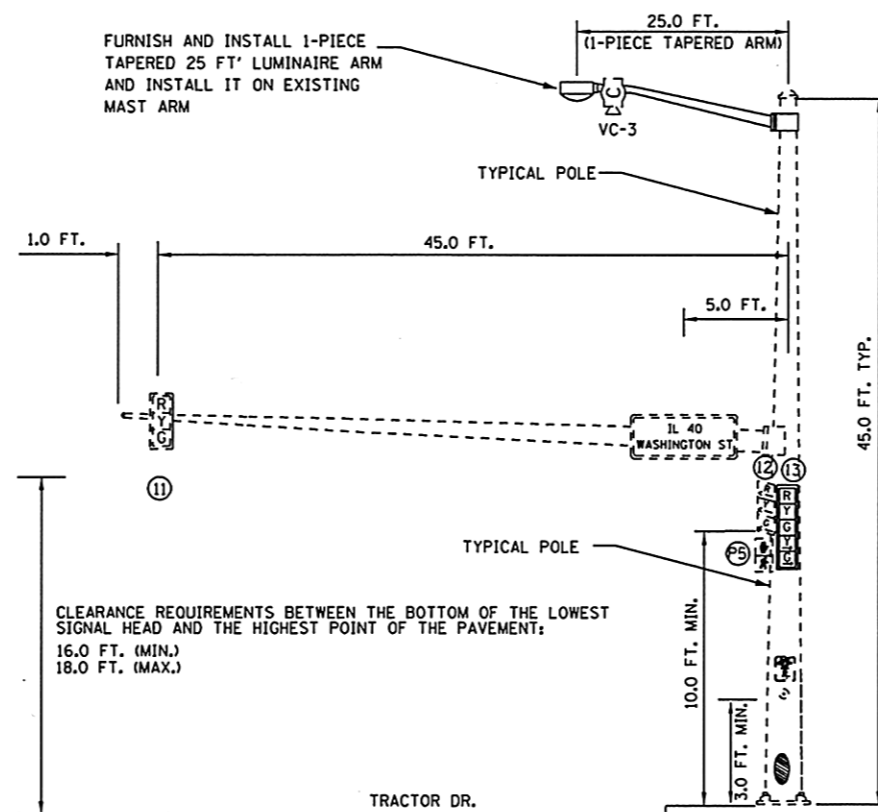

SOUTHBOUND TRAFFIC SIGNAL

SOUTHWEST CORNER OF IL 40 & RIVER RD/TRACTOR DR.

LUMINAIRE ARMS SHALL BE ONE-PIECE TAPERED ARMS IN ACCORDANCE WITH HIGHWAY STANDARD 877012-05.

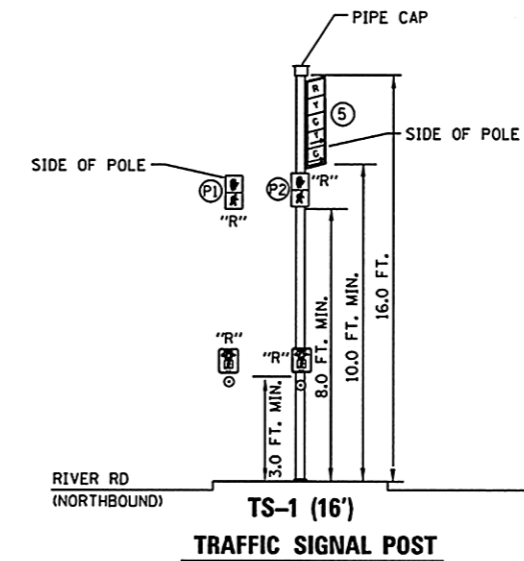

TS-1 (16')

TRAFFIC SIGNAL POST

NORTHEAST ISLAND OF IL 40 & RIVER/TRACTOR

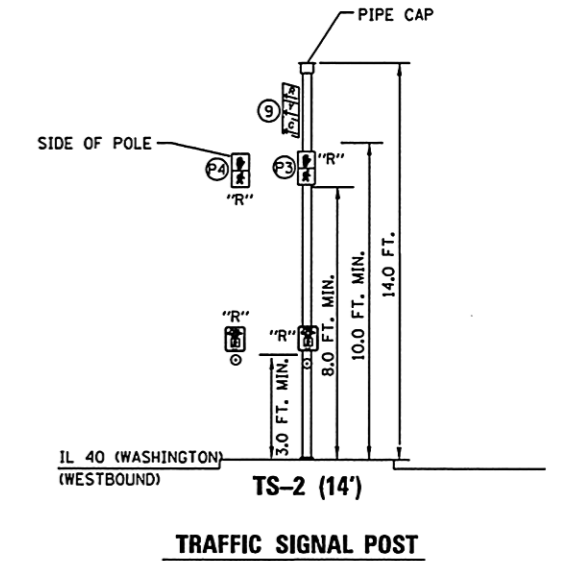

TS-2 (14')

TRAFFIC SIGNAL POST

SOUTHEAST ISLAND OF IL 40 & RIVER/TRACTOR

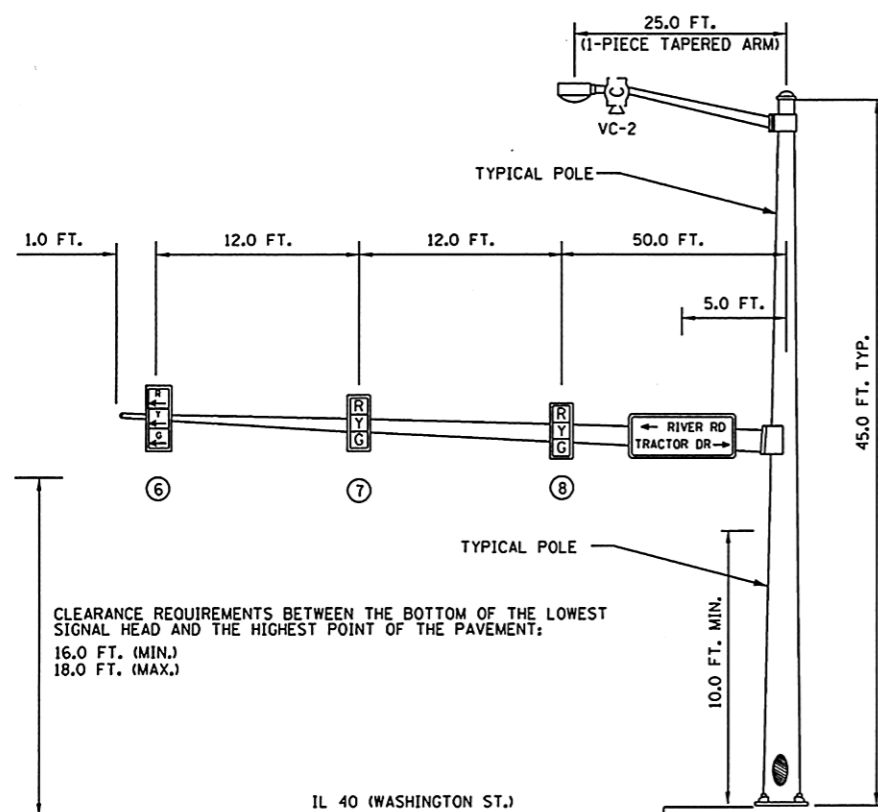

EASTBOUND TRAFFIC SIGNAL

SOUTHEAST CORNER OF IL 40 & RIVER RD/TRACTOR DR.

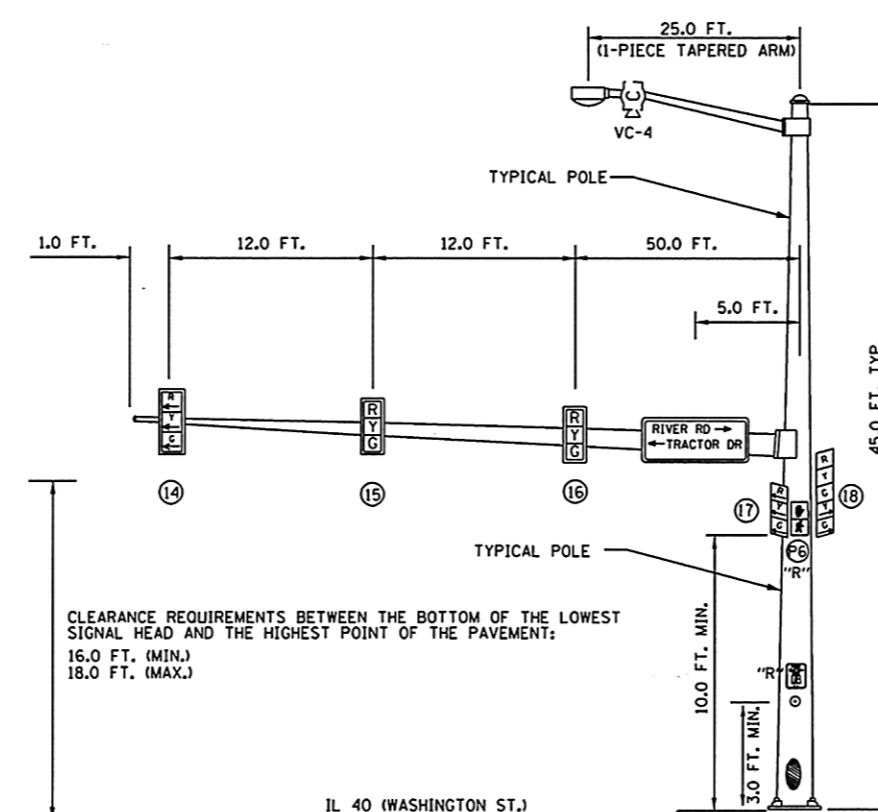

WESTBOUND TRAFFIC SIGNAL

SOUTHEAST CORNER OF IL 40 & RIVER RD/TRACTOR DR.

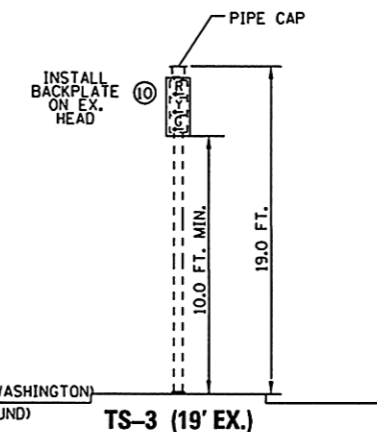

TS-3 (19' EX.)

TRAFFIC SIGNAL POST

SOUTH MEDIAN OF IL 40 & RIVER/TRACTOR

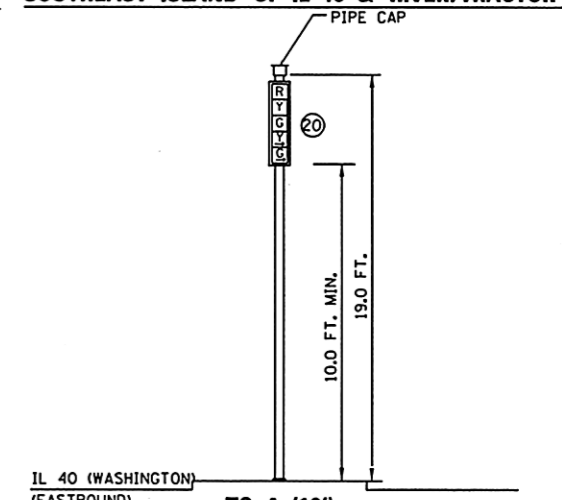

TS-4 (19')

TRAFFIC SIGNAL POST

SOUTHWEST CORNER OF IL 40 & RIVER/TRACTOR

FILE NAME = #FILE#	USER NAME = #USER#	DESIGNED -	REVISED -	STATE OF ILLINOIS DEPARTMENT OF TRANSPORTATION	MAST ARM AND TRAFFIC SIGNAL POST DETAIL			F.A.P. RTE.	SECTION	COUNTY	TOTAL SHEETS	SHEET NO.
		DRAWN -	REVISED -					404 (IL 40)	50(N)	TAZEWELL	XX	23
		CHECKED -	REVISED -					CONTRACT NO. 68C96				
		DATE -	REVISED -					FED. ROAD DIST. NO. (ILLINOIS) FED. AID PROJECT				
					SCALE:	SHEET NO.	OF SHEETS	STA.	TO STA.			

REV SHEET 4-12-17 BM