

STATE OF ILLINOIS
DEPARTMENT OF TRANSPORTATION

F.A.P. RTE.	SECTION	COUNTY	TOTAL SHEETS	SHEET NO.
840	(136, 135, 123)PP	IROQUOIS	10	1
		ILLINOIS	CONTRACT NO. 66M42	

INDEX OF SHEETS

- 1. COVER SHEET
- 2. GENERAL NOTES
- 3. SUMMARY OF QUANTITIES
- 4-6. TYPICAL SECTION
- 7. SCHEDULES
- 8-9. CLASS B PAVEMENT PATCHING DETAILS
- 10. TEMPORARY INFORMATION SIGNING

HIGHWAY STANDARDS

- 000001-08 STANDARD SYMBOLS, ABBREVIATIONS AND PATTERNS
- 001001-02 AREAS OF REINFORCEMENT BARS
- 001006 DECIMAL OF AN INCH AND OF A FOOT
- 701001-02 OFF-ROAD OPERATIONS 2L, 2W, MORE THAN 15' (4.5 m) AWAY
- 701006-05 OFF-ROAD OPERATIONS 2L, 2W, 15' (4.5 m) TO 24" (600 mm) FROM PAVEMENT EDGE
- 701301-04 LANE CLOSURE, 2L, 2W, SHORT TIME OPERATIONS
- 701336-07 LANE CLOSURE, 2L, 2W, WORK AREAS IN SERIES, FOR SPEEDS ≥ 45 MPH
- 701501-06 URBAN LANE CLOSURE, 2L, 2W, UNDIVIDED
- 701901-08 TRAFFIC CONTROL DEVICES

**PROPOSED
HIGHWAY PLANS**

**FAP ROUTE 840 (IL 49)
SECTION (136, 135, 123)PP
CLASS B PAVEMENT PATCHING
IROQUOIS COUNTY
C-93-067-22**

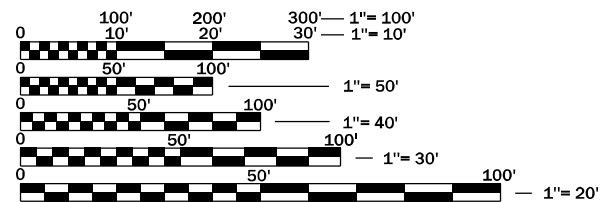
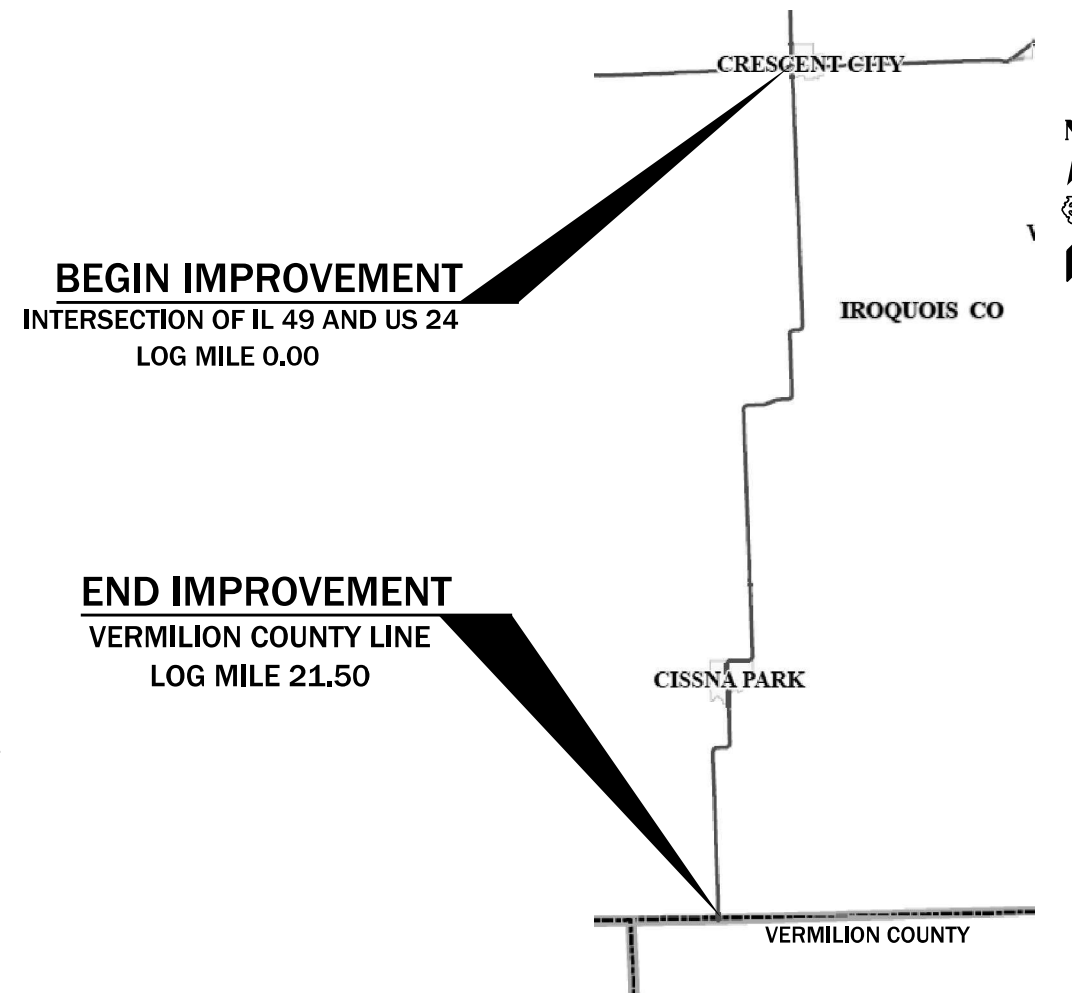
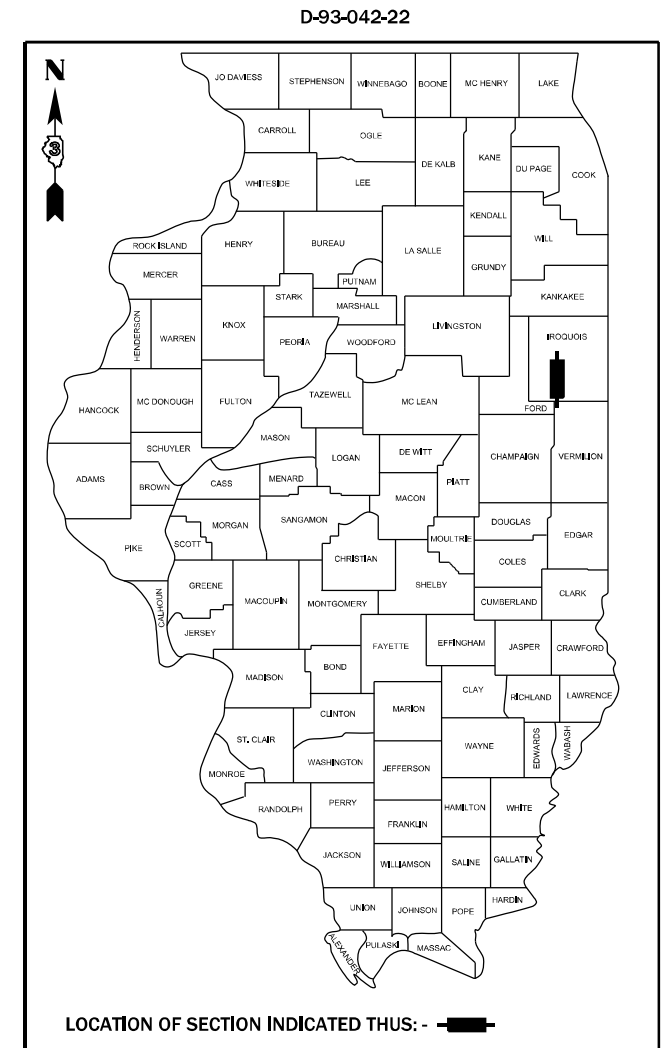

FULL SIZE PLANS HAVE BEEN PREPARED USING STANDARD ENGINEERING SCALES. REDUCED SIZED PLANS WILL NOT CONFORM TO STANDARD SCALES. IN MAKING MEASUREMENTS ON REDUCED PLANS, THE ABOVE SCALES MAY BE USED.

J.U.L.I.E.
JOINT UTILITY LOCATION INFORMATION FOR EXCAVATION
1-800-892-0123
OR 811

**PROJECT ENGINEER YOGESH PATEL P.E.
UNIT CHIEF RON WOODSHANK
DISTRICT 3 NO. (815) 434-6131
CONTRACT NO. 66M42**

GROSS LENGTH = 113,565 FT. = 21.50 MILES
NET LENGTH = 200 FT. = 0.04 MILES

FUNCTIONAL CLASSIFICATION
RURAL MINOR ARTERIAL
F.A.P. ROUTE 840 (IL-49)
2019 ADT = 1600
P.V. 78.7 % S.U. 8.7 % M.U. 12.6 %

STATE OF ILLINOIS
DEPARTMENT OF TRANSPORTATION

SUBMITTED February 02, 2022
[Signature]
REGIONAL ENGINEER

March 24, 2023
[Signature]
ENGINEER OF DESIGN AND ENVIRONMENT

March 24, 2023
[Signature]
DIRECTOR OF HIGHWAYS PROJECT IMPLEMENTATION

**PRINTED BY THE AUTHORITY
OF THE STATE OF ILLINOIS**

GENERAL NOTES

PLAN DIMENSIONS AND DETAILS RELATIVE TO EXISTING PLANS ARE SUBJECT TO NOMINAL CONSTRUCTION VARIATIONS. THE CONTRACTOR SHALL FIELD VERIFY EXISTING DIMENSIONS AND DETAILS AFFECTING NEW CONSTRUCTION AND MAKE NECESSARY APPROVED ADJUSTMENTS PRIOR TO CONSTRUCTION OR ORDERING OF MATERIALS. SUCH VARIATIONS SHALL NOT BE CAUSE FOR ADDITIONAL COMPENSATION FOR A CHANGE IN SCOPE OF WORK; HOWEVER, THE CONTRACTOR WILL BE PAID FOR THE QUANTITY ACTUALLY FURNISHED AT THE UNIT PRICE BID FOR THE WORK.

ALL EXCAVATED MATERIAL, WHICH INCLUDES DIGGING OR GRADING OF ANY SOIL OR FILL MATERIAL, WITH THE EXCEPTION OF AGGREGATE FILLS, MUST BE INCORPORATED WITHIN THE IDOT RIGHT OF WAY.

THE CONTRACTOR SHALL CONTACT JULIE AT LEAST 48 HOURS PRIOR TO EXCAVATION TO DETERMINE WHICH UTILITIES ARE IN THE AREA.

COMMITMENTS

STATE OF ILLINOIS
DEPARTMENT OF TRANSPORTATION
DISTRICT THREE
AS BUILT INFORMATION

SUPERVISING CONSTRUCTION FIELD ENGINEER

RESIDENT ENGINEER / TECHNICIAN

START & END DATES
OF CONSTRUCTION:

INSPECTORS:

STATE OF ILLINOIS
DEPARTMENT OF TRANSPORTATION
DISTRICT THREE

PREPARED BY: _____
DISTRICT STUDIES & PLANS ENGINEER

DATE: _____

EXAMINED BY: _____
DISTRICT CONSTRUCTION ENGINEER

DISTRICT MATERIALS ENGINEER

DISTRICT OPERATIONS ENGINEER

FILE NAME =	USER NAME = woodshank1	DESIGNED - EVAN MARINI	REVISED -	STATE OF ILLINOIS DEPARTMENT OF TRANSPORTATION	GENERAL NOTES	F.A.P. RTE.	SECTION	COUNTY	TOTAL SHEETS	SHEET NO.	
pw:\idot\pw\berkeley.com\PWIDOT\Documents\IDOT Office\District 3\Projects\I386M42\CADData\I386M42 - PLANS.dgn	DRAWN - EVAN MARINI	REVISED -	840			(136, 135, 123)PP	IROQUOIS	10	2		
Default	PLOT SCALE = 100,0000' / in.	CHECKED - RON WOODSHANK	REVISED -			CONTRACT NO. 66M42					
	PLOT DATE = 1/12/2022	DATE - 1/22/2019	REVISED -			SCALE:	SHEET 1	OF 1	SHEETS	STA.	TO STA.

CODE NO.	ITEM	UNIT	TOTAL QUANTITY	CONSTRUCTION CODE	
				CONTRACT MAINTENANCE 100% STATE	ROADWAY
				0006	
				RURAL	
44201031	CLASS B PATCHES, TYPE 11, 15 INCH	SQ YD	420		420
44201299	DOWEL BARS 1 1/2"	EACH	1012		1012
44213200	SAW CUTS	FOOT	2354		2354
67100100	MOBILIZATION	L SUM	1		1
70100600	TRAFFIC CONTROL AND PROTECTION, STANDARD 701336	L SUM	1		1
70102620	TRAFFIC CONTROL AND PROTECTION, STANDARD 701501	L SUM	1		1
Z0030850	TEMPORARY INFORMATION SIGNING	SQ FT	42		42

FILE NAME =	USER NAME = woodshank1	DESIGNED - EVAN MARINI	REVISED -
pw:\idot\pw\berkeley.com\PWIDOT\Documents\IDOT Office\District 3\Projects\I386M42\CADData\I386M42 - PLANS.dwg		DRAWN - EVAN MARINI	REVISED -
Default	PLOT SCALE = 100.0000' / in.	CHECKED - RON WOODSHANK	REVISED -
	PLOT DATE = 2/22/2022	DATE - 1/22/2019	REVISED -

**STATE OF ILLINOIS
DEPARTMENT OF TRANSPORTATION**

SUMMARY OF QUANTITIES

SCALE: SHEET 1 OF 1 SHEETS STA. TO STA.

F.A.P. RTE.	SECTION	COUNTY	TOTAL SHEETS	SHEET NO.
840	(136, 135, 123)PP	IROQUOIS	10	3
			CONTRACT NO. 66M42	
		ILLINOIS	FED. AID PROJECT	

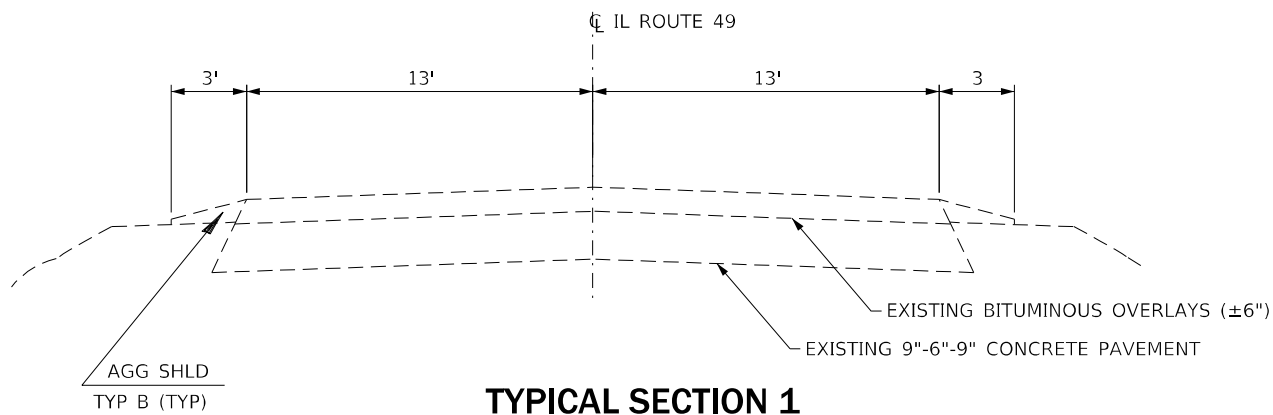

TYPICAL SECTION 1

LOG MILE 0.00 TO LOG MILE 5.94
 LOG MILE 6.06 TO LOG MILE 6.21
 LOG MILE 6.33 TO LOG MILE 7.76
 LOG MILE 7.76 TO LOG MILE 8.57

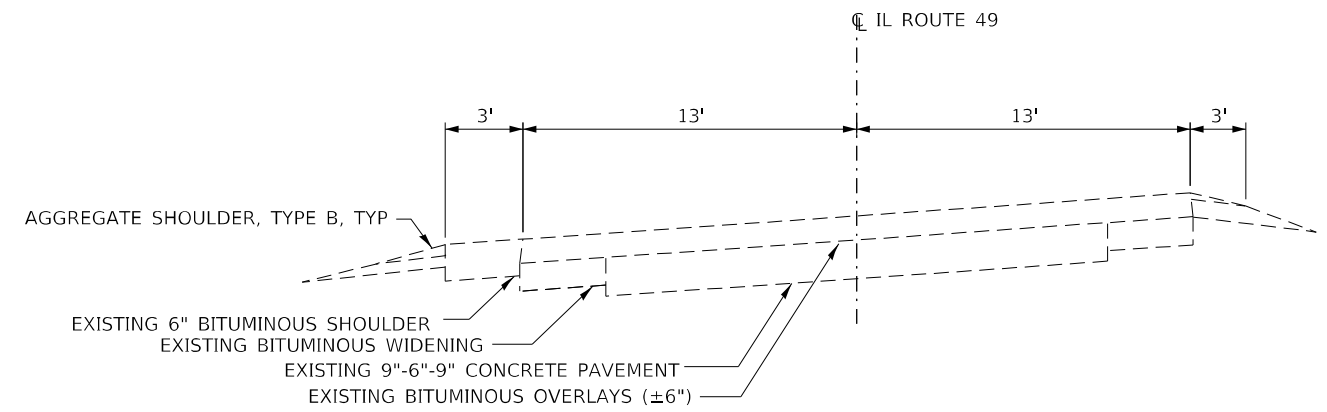

TYPICAL SECTION NO. 4

LOG MILE 6.21 TO LOG MILE 6.33

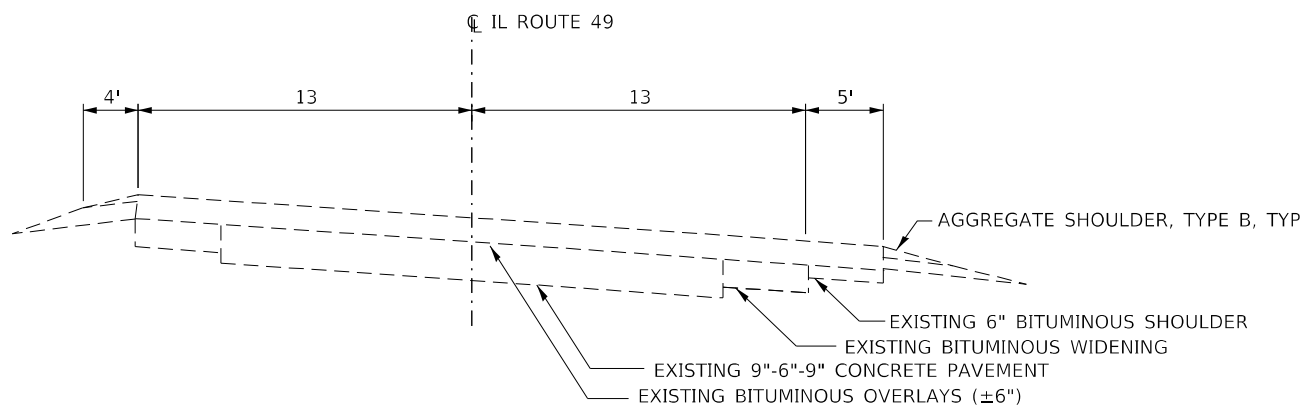

TYPICAL SECTION NO. 3

LOG MILE 5.94 TO LOG MILE 6.06
 LOG MILE 7.76 TO LOG MILE 7.87

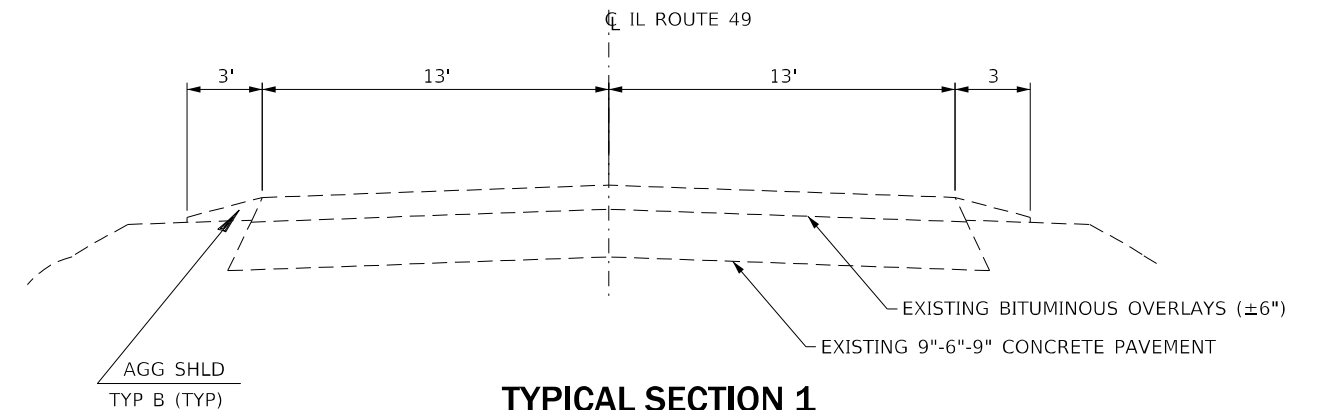

TYPICAL SECTION 1

LOG MILE 8.57 TO LOG MILE 8.86
 LOG MILE 8.98 TO LOG MILE 14.67
 LOG MILE 14.79 TO LOG MILE 15.21
 LOG MILE 18.20 TO LOG MILE 21.50

FILE NAME =	USER NAME = woodshank1	DESIGNED - EVAN MARINI	REVISED -
pw:\idol-pw\berkeley.com\PWIDOT\Documents\IDOT Office\District 3\Projects\I386M42\CADData\I386M42 - PLANS.dwg		DRAWN - EVAN MARINI	REVISED -
Default	PLOT SCALE = 100,0000' / in.	CHECKED - RON WOODSHANK	REVISED -
	PLOT DATE = 1/12/2022	DATE - 1/22/2019	REVISED -

STATE OF ILLINOIS
 DEPARTMENT OF TRANSPORTATION

TYPICAL SECTIONS

SCALE: SHEET 1 OF 3 SHEETS STA. TO STA.

F.A.P. RTE.	SECTION	COUNTY	TOTAL SHEETS	SHEET NO.
840	(136, 135, 123)PP	IROQUOIS	10	4
CONTRACT NO. 66M42				
ILLINOIS		FED. AID PROJECT		

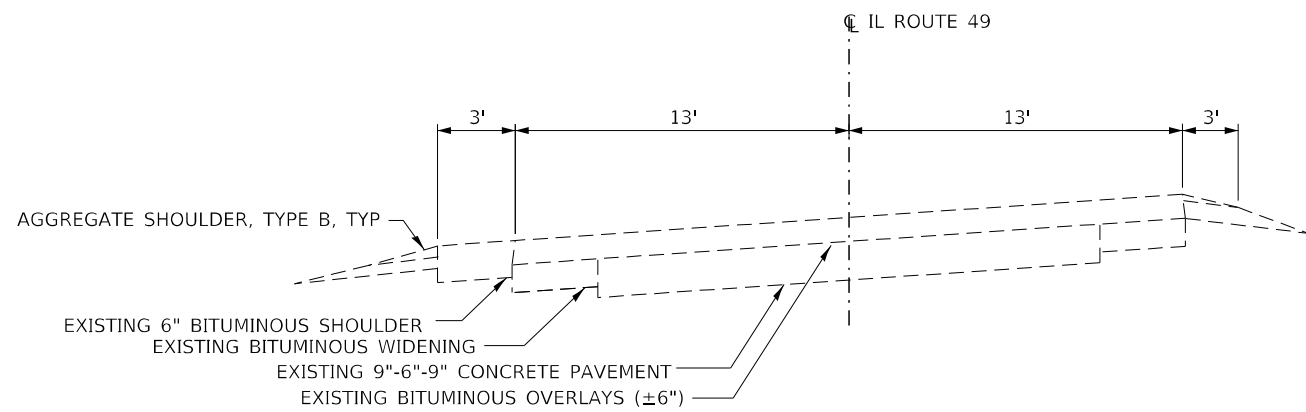

TYPICAL SECTION NO. 4
 LOG MILE 8.86 TO LOG MILE 8.98
 LOG MILE 15.21 TO LOG MILE 15.34

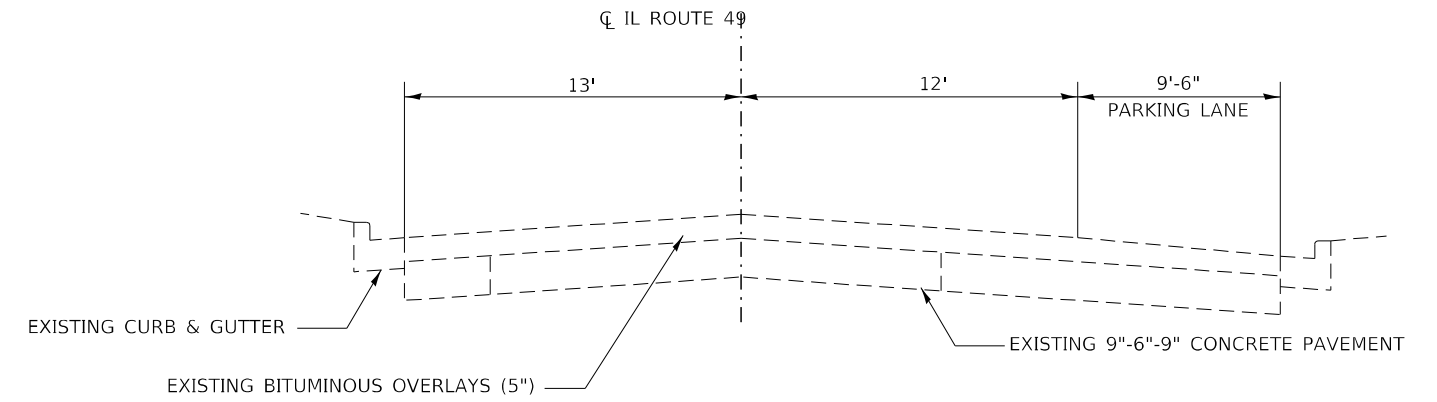

TYPICAL SECTION NO. 7
 LOG MILE 15.34 TO LOG MILE 17.38

NOTE: NO WORK WILL BE PERFORMED IN THE PARKING LANES

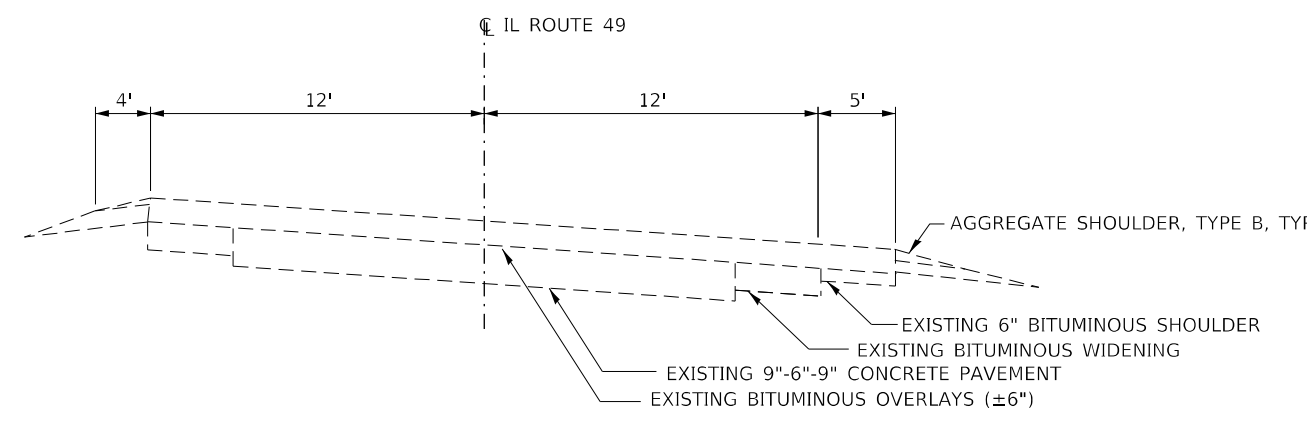

TYPICAL SECTION NO. 3
 LOG MILE 14.67 TO LOG MILE 14.79

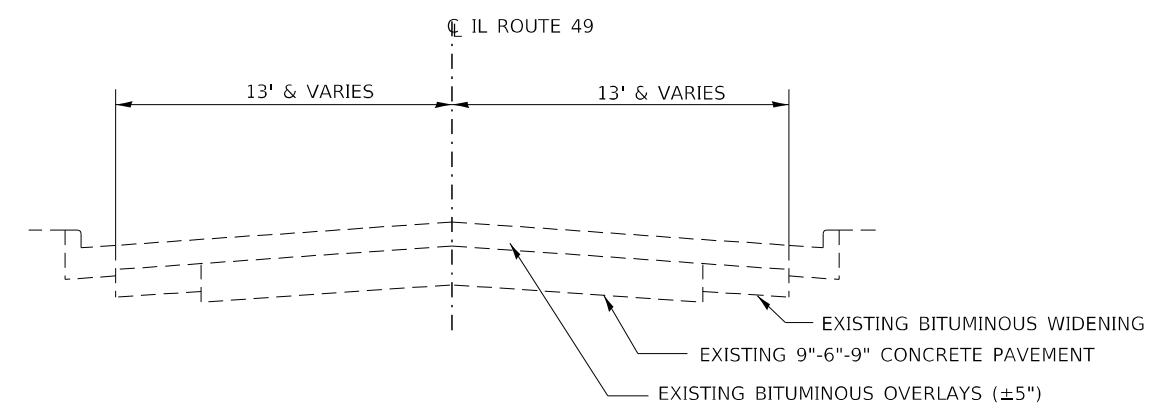

TYPICAL SECTION NO. 5
 LOG MILE 17.38 TO LOG MILE 17.61

NOTE: NO WORK WILL BE PERFORMED IN THE PARKING LANES

FILE NAME =	USER NAME = woodshank1	DESIGNED - EVAN MARINI	REVISED -	STATE OF ILLINOIS DEPARTMENT OF TRANSPORTATION	TYPICAL SECTIONS			F.A.P. RTE.	SECTION	COUNTY	TOTAL SHEETS	SHEET NO.
pw:\idol-pw.bentley.com\PWIDOT\Documents\IDOT Office\District 3\Projects\ID366M42\CADData\ID366M42 - PLANS.dwg	DRAWN - EVAN MARINI	REVISIONS						840	(136, 135, 123)PP	IROQUOIS	10	5
Default	PLOT SCALE = 100,0000' / in.	CHECKED - RON WOODSHANK	REVISIONS		SCALE: SHEET 2 OF 3 SHEETS STA. TO STA.			CONTRACT NO. 66M42				
	PLOT DATE = 1/12/2022	DATE - 1/22/2019	REVISIONS		ILLINOIS FED. AID PROJECT							

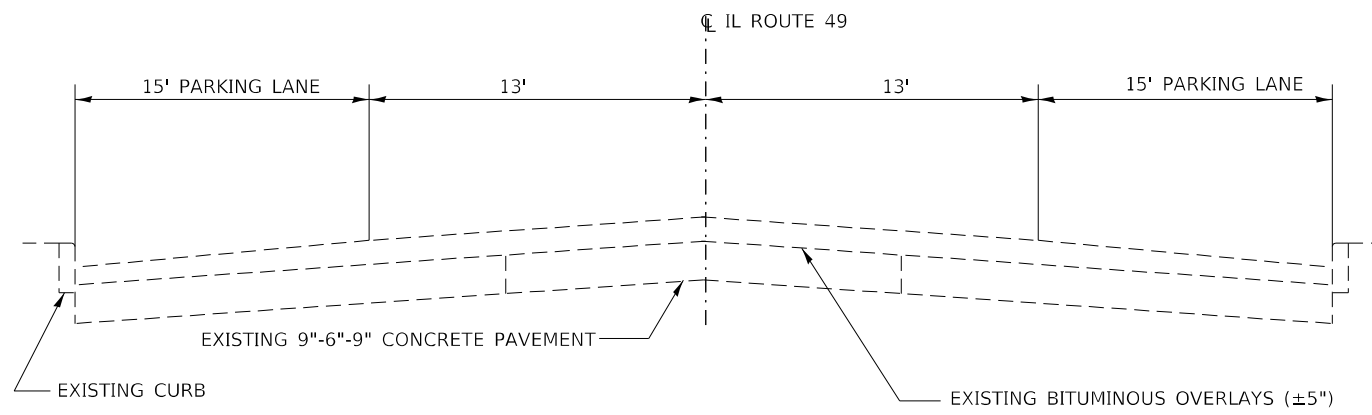

TYPICAL SECTION NO. 6

LOG MILE 17.61 TO LOG MILE 18.20

NOTE: NO WORK WILL BE PERFORMED IN THE PARKING LANES

FILE NAME =	USER NAME = woodshank1	DESIGNED - EVAN MARINI	REVISED -
pw:\idol-pw.bentley.com\PWIDOT\Documents\IDOT Office\District 3\Projects\ID366M42\CADData\ID366M42 - PLANS.dwg		DRAWN - EVAN MARINI	REVISED -
Default	PLOT SCALE = 100,0000' / in.	CHECKED - RON WOODSHANK	REVISED -
	PLOT DATE = 1/12/2022	DATE - 1/22/2019	REVISED -

**STATE OF ILLINOIS
DEPARTMENT OF TRANSPORTATION**

TYPICAL SECTIONS

SCALE: SHEET 3 OF 3 SHEETS STA. TO STA.

F.A.P. RTE.	SECTION	COUNTY	TOTAL SHEETS	SHEET NO.
840	(136, 135, 123)PP	IROQUOIS	10	6
CONTRACT NO. 66M42				
ILLINOIS FED. AID PROJECT				

PATCHING SCHEDULE

SOUTHBOUND LANE				
LOCATION	PATCH LENGTH	CLASS B TYPE II 15"	DOWEL BARS 1 1/2"	SAW CUTS
LOG MILE	(FT)	SQ YD	EACH	FOOT
0.4	8	12	22	55
0.7	6	9	22	51
1.1	6	9	22	51
9.1	6	9	22	51
4.2	6	9	22	51
4.3	6	9	22	51
11.8	6	9	22	51
12.3	6	9	22	51
13.2	6	9	22	51
13.8	6	9	22	51
14.1	6	9	22	51
14.3	6	9	22	51
15.4	6	9	22	51
15.5	6	9	22	51
15.6	6	9	22	51
15.8	6	9	22	51
15.9	6	9	22	51
16.3	6	9	22	51
16.3	6	9	22	51
16.5	6	9	22	51
18.8	6	9	22	51
20.5	6	9	22	51
20.7	6	9	22	51
21.2	6	9	22	51
TOTAL	146	219	528	1228

PATCHING SCHEDULE

NORTHBOUND LANE				
LOCATION	PATCH LENGTH	CLASS B TYPE II 15"	DOWEL BARS 1 1/2"	SAW CUTS
LOG MILE	(FT)	SQ YD	EACH	FOOT
17.5	6	9	22	51
17.4	6	9	22	51
17.0	6	9	22	51
16.0	6	9	22	51
15.9	6	9	22	51
15.8	6	9	22	51
15.6	6	9	22	51
15.5	6	9	22	51
15.4	8	12	22	55
14.9	6	9	22	51
14.9	6	9	22	51
14.7	6	9	22	51
4.3	6	9	22	51
4.2	6	9	22	51
4.1	6	9	22	51
3.7	6	9	22	51
1.2	6	9	22	51
0.7	6	9	22	51
0.5	6	9	22	51
0.5	6	9	22	51
0.4	6	9	22	51
0.1	6	9	22	51
TOTAL	134	201	484	1126

FILE NAME =	USER NAME = woodshank1	DESIGNED - EVAN MARINI	REVISED -
pw:\idot\pw\berkeley.com\PWIDOT\Documents\IDOT Office\District 3\Projects\I386M42\CADData\I386M42 - PLANS.dwg		DRAWN - EVAN MARINI	REVISED -
Default	PLOT SCALE = 100,0000 / 1 in.	CHECKED - RON WOODSHANK	REVISED -
	PLOT DATE = 2/22/2022	DATE - 1/22/2019	REVISED -

STATE OF ILLINOIS
DEPARTMENT OF TRANSPORTATION

SCHEDULES

SCALE: SHEET 1 OF 1 SHEETS STA. TO STA.

F.A.P. RTE.	SECTION	COUNTY	TOTAL SHEETS	SHEET NO.
840	(136, 135, 123)PP	IROQUOIS	10	7
			CONTRACT NO. 66M42	
		ILLINOIS	FED. AID PROJECT	

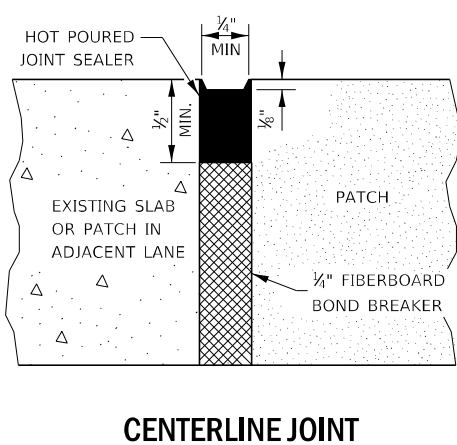
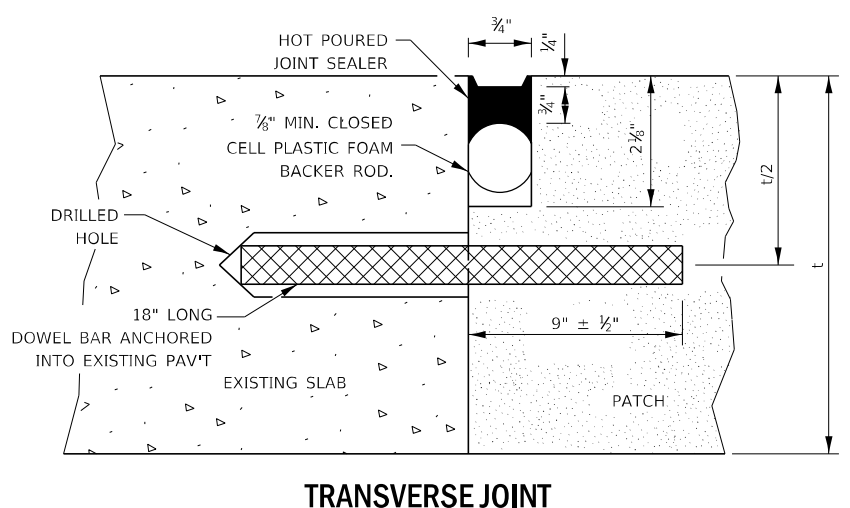
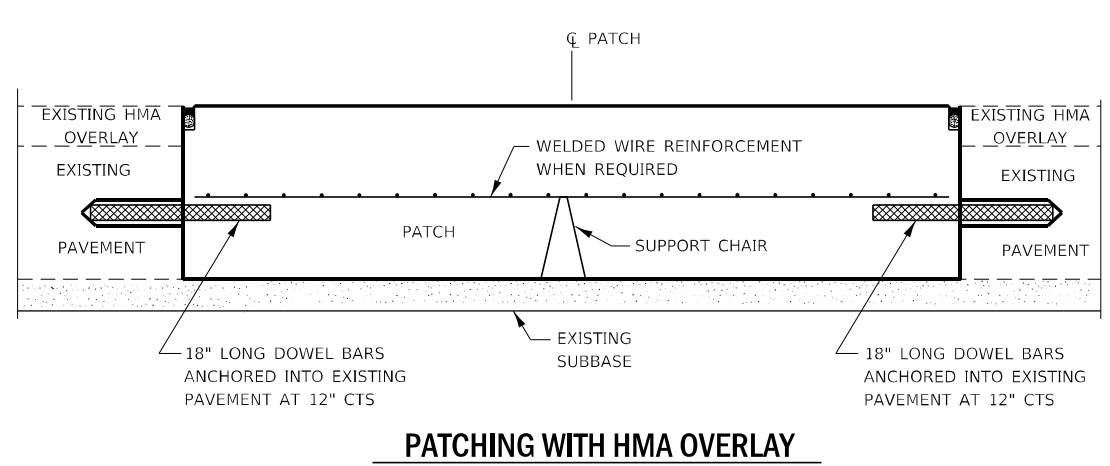
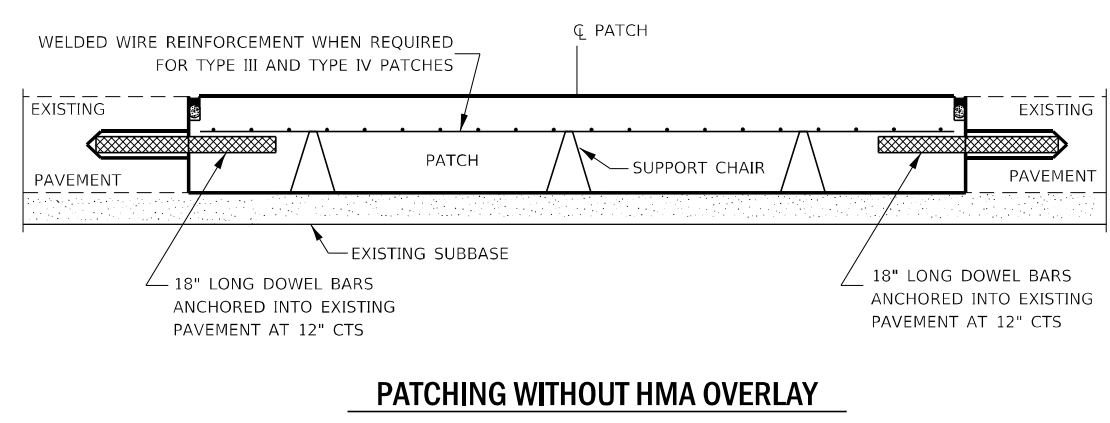
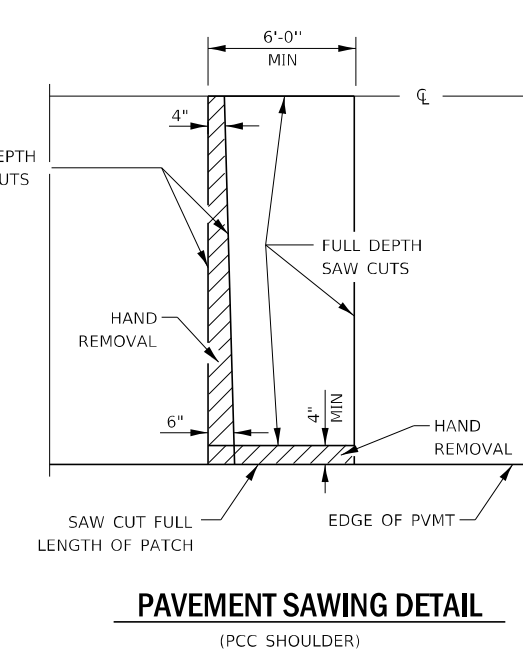
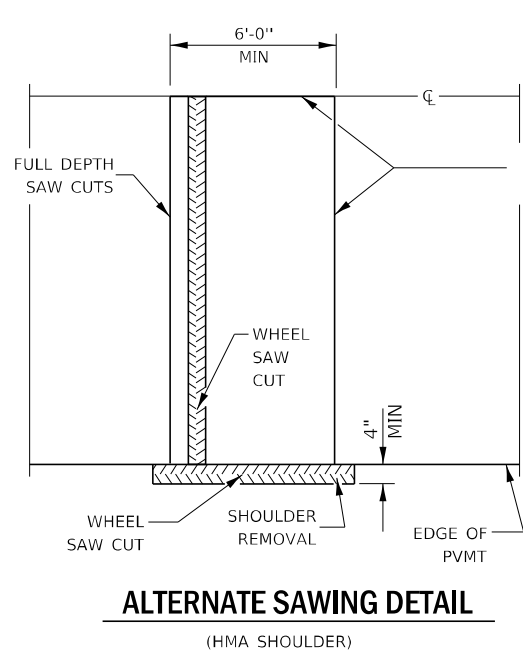
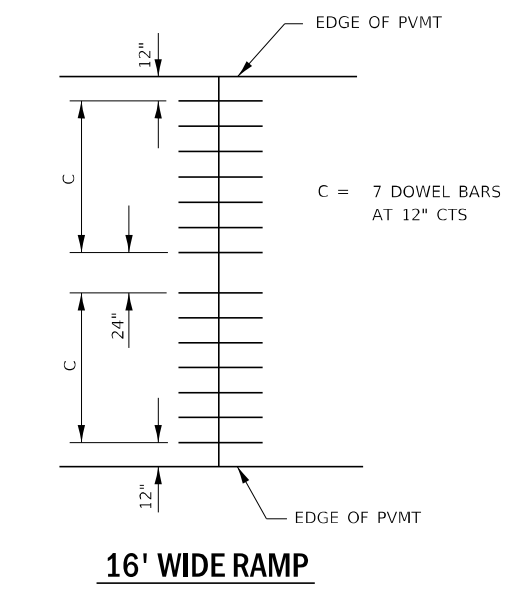
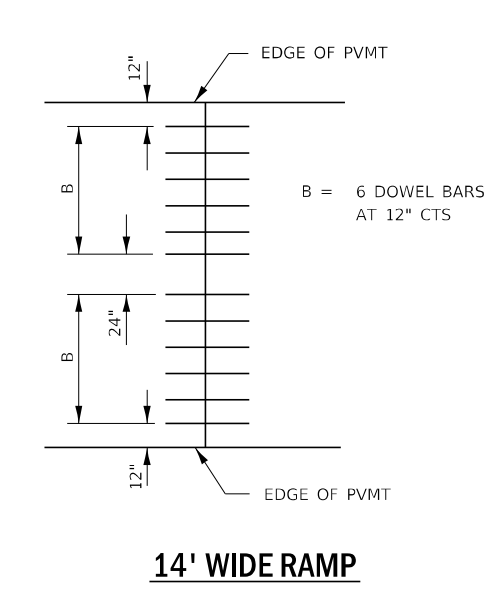
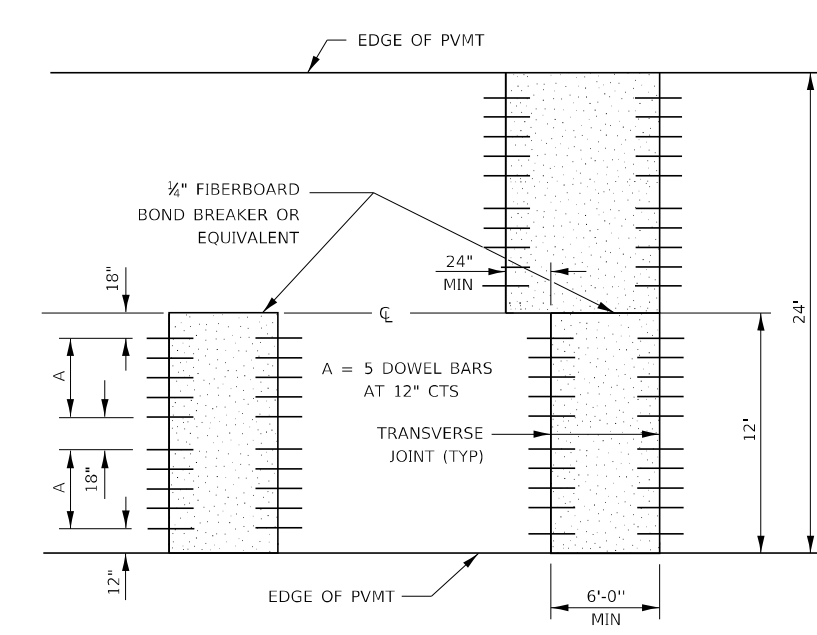
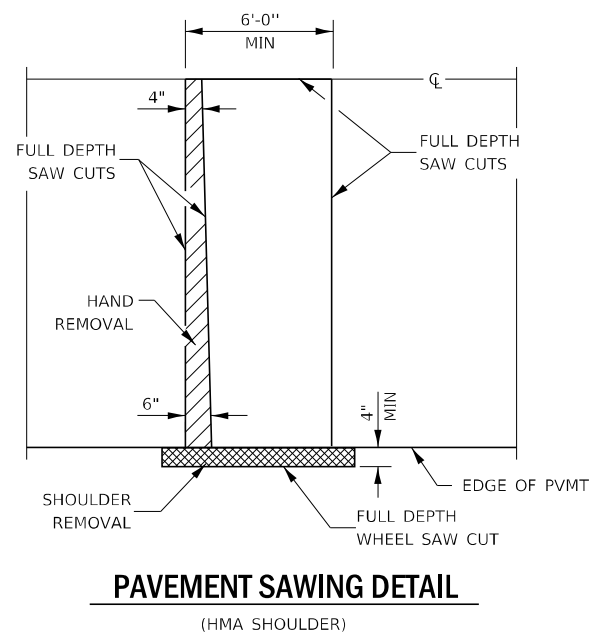

DOWEL BAR TABLE

PAVEMENT THICKNESS	DOWEL BAR DIAMETER	HOLE DIAMETER
8" OR GREATER	1 1/2"	1 3/8"
7" THRU 7.99"	1 1/4"	1 3/8"
LESS THAN 7"	1"	1 3/8"

GENERAL NOTES

THE TRANSVERSE JOINTS FOR CLASS B PATCHES SHALL ALIGN WITH JOINTS OR CRACKS IN THE ADJACENT LANE WHENEVER POSSIBLE.

SEE STANDARD 420701 FOR DETAILS OF PAVEMENT WELDED WIRE REINFORCEMENT.

MODEL: Default
 FILE: hma16.pxd
 PROJECT: D:\Projects\1356642\CADD\Drawings\1356642 - PLANS.dwg
 PLOT DATE: 1/12/2022

USER NAME = woodshank	DESIGNED - EVAN MARINI	REVISED -
PLOT SCALE = 100,0000' / in.	DRAWN - EVAN MARINI	REVISED -
PLOT DATE = 1/12/2022	CHECKED - RON WOODSHANK	REVISED -
	DATE - 1/22/2019	REVISED -

STATE OF ILLINOIS
DEPARTMENT OF TRANSPORTATION

CLASS B PATCHING DETAILS

SCALE: SHEET 1 OF 2 SHEETS STA. TO STA.

F.A.P. RTE.	SECTION	COUNTY	TOTAL SHEETS	SHEET NO.
840	(136, 135, 123)PP	IROQUOIS	10	8
CONTRACT NO. 66M42				
ILLINOIS FED. AID PROJECT				

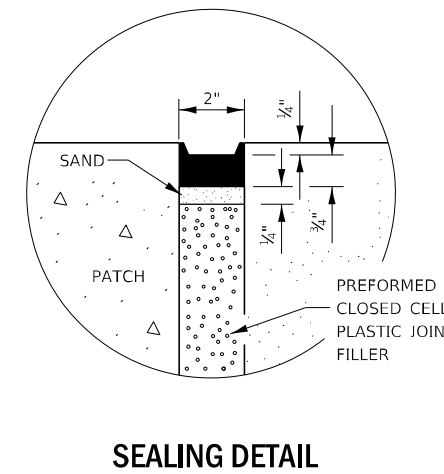
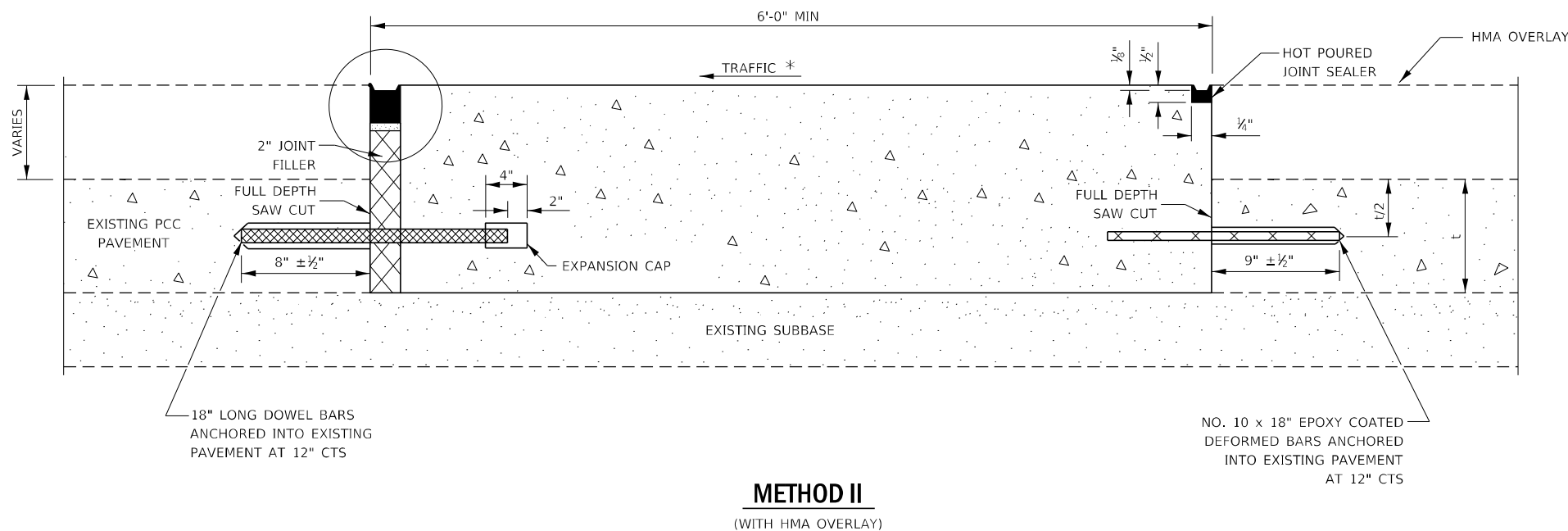
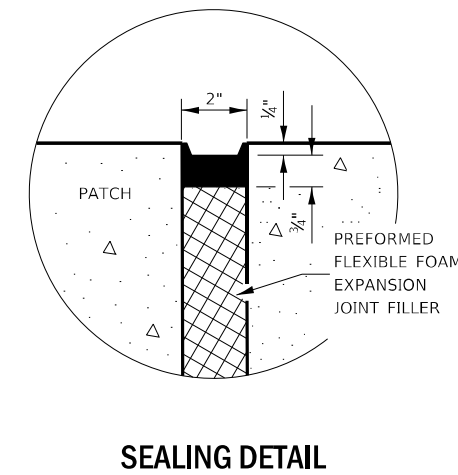
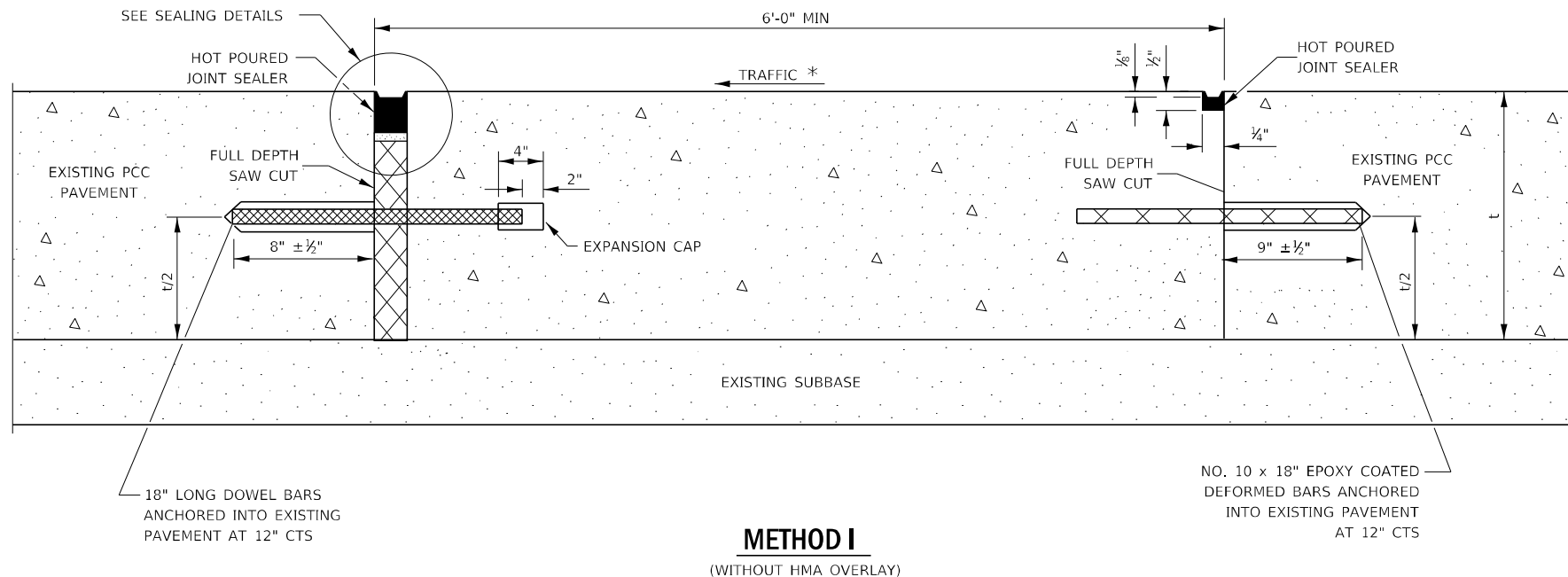

NOTE

* WHEN RE-ESTABLISHING A TRANSVERSE EXPANSION JOINT ON A TWO-WAY ROAD, REVERSE THE ORIENTATION OF THE DOWEL BARS WITH RESPECT TO TRAFFIC FOR ONE OF THE PATCHES SUCH THAT THE JOINT WILL BE CONTINUOUS ACROSS BOTH LANES.

MODEL: Default
FILE NAME: p:\build\paw_bentley.com\PIV\DOT\Documents\DOT Office\Dir\drf_3\Project\10366442\CADD\Drawings\366M42 - PLANS.dgn

USER NAME = woodshank	DESIGNED - EVAN MARINI	REVISED -
PLOT SCALE = 100,0000' / in.	DRAWN - EVAN MARINI	REVISED -
PLOT DATE = 1/12/2022	CHECKED - RON WOODSHANK	REVISED -
	DATE - 1/22/2019	REVISED -

**STATE OF ILLINOIS
DEPARTMENT OF TRANSPORTATION**

CLASS B PATCHING DETAILS

SCALE: SHEET 2 OF 2 SHEETS STA. TO STA.

F.A.P. RTE.	SECTION	COUNTY	TOTAL SHEETS	SHEET NO.
840	(136, 135, 123)PP	IROQUOIS	10	9
CONTRACT NO. 66M42				
		ILLINOIS	FED. AID PROJECT	

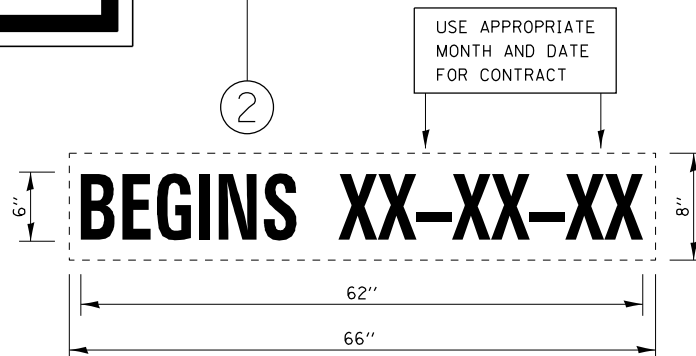
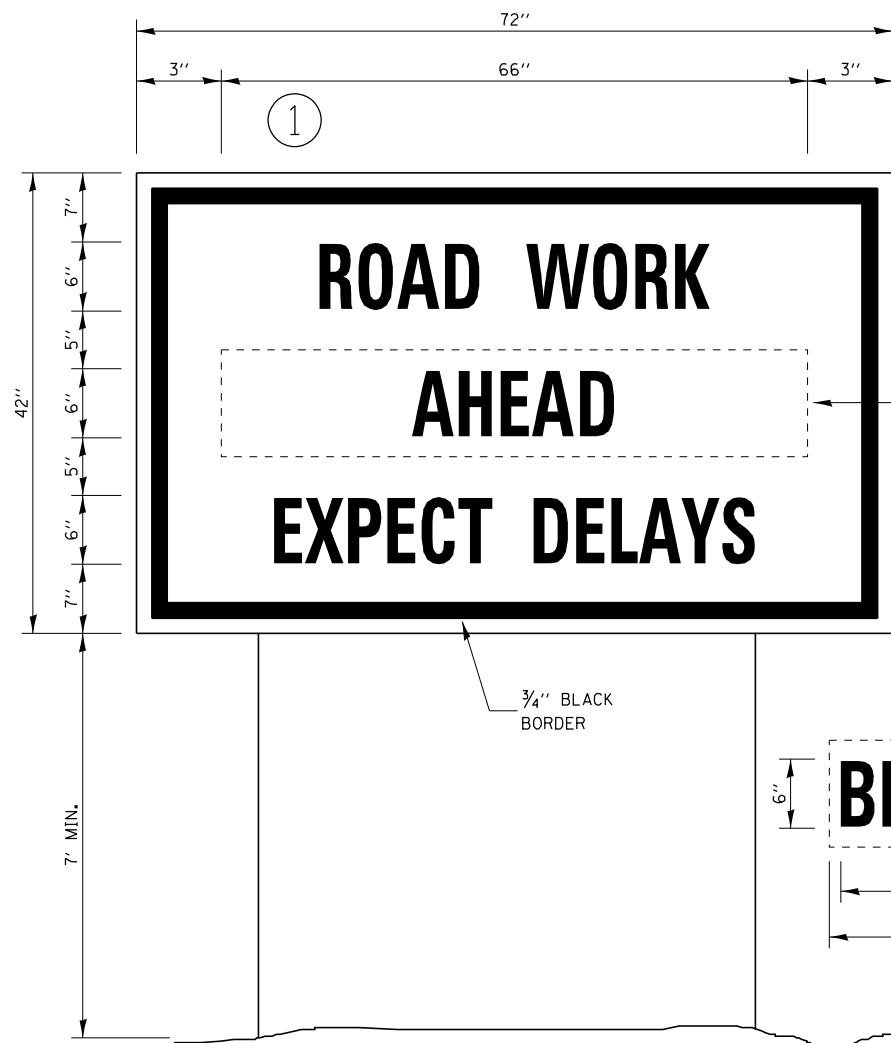

TEMPORARY INFORMATION SIGNING

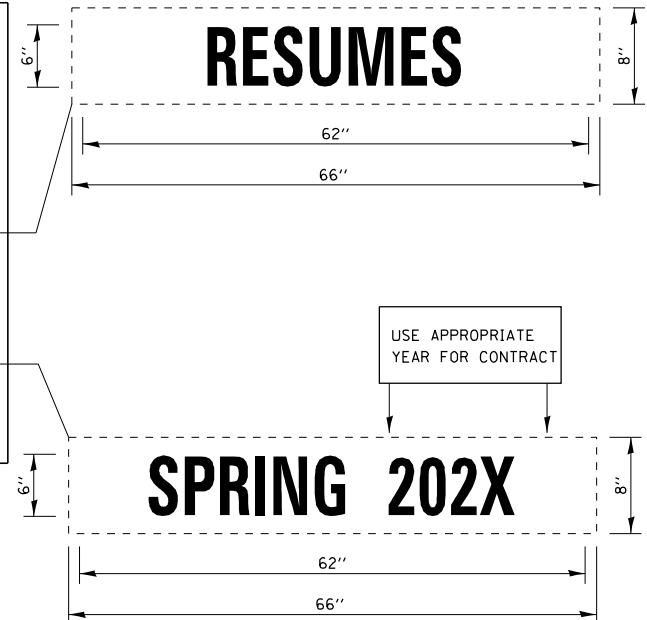
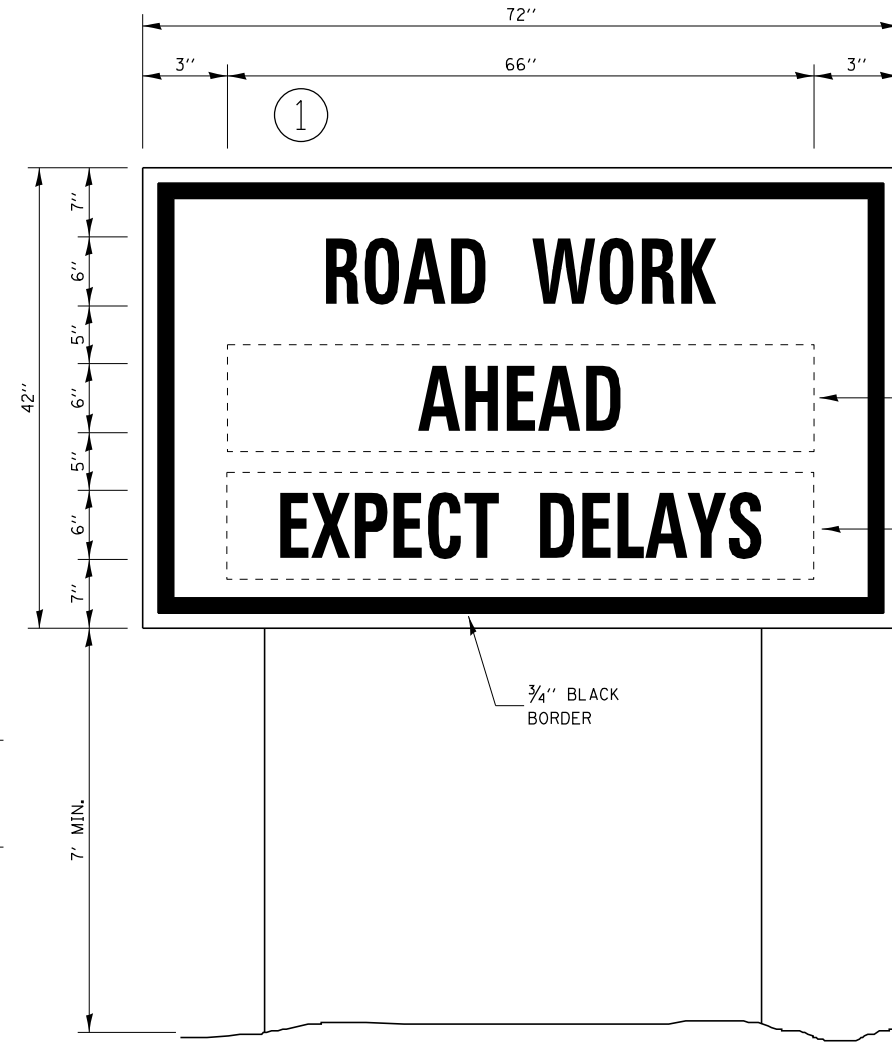

WINTER SHUT DOWN SIGNING

NOTES:

1. USE 6" D BLACK LETTERING ON FLOURESENT ORANGE BACKGROUND.
2. ERECT SIGNS AT LOCATIONS IN ADVANCE OF THE "ROAD CONSTRUCTION AHEAD" SIGNS AS DIRECTED BY THE ENGINEER.
3. ERECT SIGN ① WITH INSTALLED PANEL ② A MINIMUM OF ONE WEEK PRIOR TO THE START OF THE LANE CLOSURE.
4. REMOVE PANEL ② ON THAT DATE.
5. SEE SPECIAL PROVISION "TEMPORARY INFORMATION SIGNING" FOR ADDITIONAL INFORMATION.
6. WILL BE PAID FOR PER SQ FT AS "TEMPORARY INFORMATION SIGNING". EACH SIGN = 21 SQ FT AND THE DATE PANEL ② WILL NOT BE MEASURED SEPARATELY FOR PAYMENT.

FILE NAME =	USER NAME = woodshank1	DESIGNED - EVAN MARINI	REVISED -	STATE OF ILLINOIS DEPARTMENT OF TRANSPORTATION	TEMPORARY INFORMATION SIGNING			F.A.P. RTE.	SECTION	COUNTY	TOTAL SHEETS	SHEET NO.
pw:\illdot\pw\berntley.com\PWIDOT\Documents\IDOT Office\District 3\Projects\3\66M42\CADData\366M42 - PLANS.dwg	DRAWN - EVAN MARINI	REVISIED -	840					(136, 135, 123)PP	IROQUOIS	10	10	
Default	PLOT SCALE = 100,0000' / in.	CHECKED - RON WOODSHANK	REVISED -		CONTRACT NO. 66M42			ILLINOIS	FED. AID PROJECT			
	PLOT DATE = 1/12/2022	DATE - 1/22/2019	REVISED -		SCALE:	SHEET 1	OF 1	SHEETS	STA.	TO STA.		