

INDEX OF SHEETS

PAGE	DESCRIPTION
1	COVER
2	GENERAL NOTES AND COMMITMENTS
3-6	SUMMARY OF QUANTITIES
7	TYPICAL SECTIONS
8-10	SCHEDULE OF QUANTITIES
11-12	REMOVAL PLANS
13-14	PLAN & PROFILE
15	STAGING TYPICAL SECTIONS
16-18	STAGE 1 TRAFFIC CONTROL
19-21	STAGE 2 TRAFFIC CONTROL
22-23	EROSION CONTROL
24	RIGHT OF WAY
25-33	APPROACH PAVEMENT
34-38	EXISTING PLANS
39-41	DETAILS
41-49	CROSS SECTIONS

LIST OF ILLINOIS DOT HIGHWAY STANDARDS

000001-08	STANDARD SYMBOLS, ABBREVIATIONS AND PATTERNS
001001-02	AREAS OF REINFORCEMENT BARS
001006	DECIMAL OF AN INCH AND OF A FOOT
280001-07	TEMPORARY EROSION CONTROL SYSTEMS
420401-13	PAVEMENT CONNECTOR (PCC) FOR BRIDGE APPROACH SLAB
482001-02	HMA SHOULDER ADJACENT TO FLEXIBLE PAVEMENT
630001-12	STEEL PLATE BEAM GUARDRAIL
630201-07	PCC/HMA STABILIZATION AT STEEL PLATE BEAM GUARDRAIL
630301-09	SHOULDER WIDENING FOR TYPE 1 (SPECIAL) GUARDRAIL TERMINALS
631031-18	TRAFFIC BARRIER TERMINAL, TYPE 6
643001-02	SAND MODULE IMPACT ATTENUATORS
701001-02	OFF-ROAD OPERATIONS 2L, 2W, MORE THAN 15' AWAY
701006-05	OFF-ROAD OPERATIONS 2L, 2W, 15' TO 24" FROM PAVEMENT EDGE
701011-04	OFF-ROAD MOVING OPERATIONS 2L, 2W, DAY ONLY
701201-05	LANE CLOSURE, 2L, 2W, DAY ONLY, FOR SPEEDS ≥ 45 MPH
701301-04	LANE CLOSURE, 2L, 2W, SHORT TIME OPERATIONS
701306-04	LANE CLOSURE, 2L, 2W, SLOW MOVING OPERATIONS DAY ONLY, FOR SPEEDS ≥ 45 MPH
701311-03	LANE CLOSURE, 2L, 2W, MOVING OPERATIONS - DAY ONLY
701321-18	LANE CLOSURE, 2L, 2W, BRIDGE REPAIR WITH BARRIER
701901-08	TRAFFIC CONTROL DEVICES
704001-08	TEMPORARY CONCRETE BARRIER
725001-01	OBJECT AND TERMINAL MARKERS
781001-04	TYPICAL APPLICATIONS RAISED REFLECTIVE PAVEMENT MARKERS
782006-01	GUARDRAIL AND BARRIER WALL REFLECTOR MOUNTING DETAILS

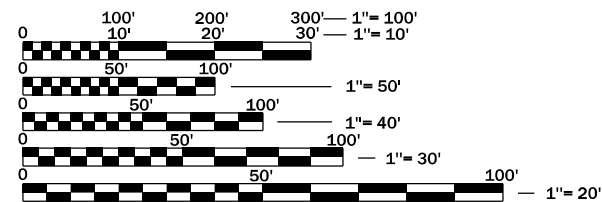

FULL SIZE PLANS HAVE BEEN PREPARED USING STANDARD ENGINEERING SCALES. REDUCED SIZED PLANS WILL NOT CONFORM TO STANDARD SCALES. IN MAKING MEASUREMENTS ON REDUCED PLANS, THE ABOVE SCALES MAY BE USED.

J.U.L.I.E.  
JOINT UTILITY LOCATION INFORMATION FOR EXCAVATION  
1-800-892-0123  
OR 811

PROJECT ENGINEER: JOSEPH KANNEL, P.E.  
UNIT CHIEF: DARCY MITCHELL  
DISTRICT 3 NO. (815) 434-6131  
CONTRACT NO. 66M70

STATE OF ILLINOIS  
DEPARTMENT OF TRANSPORTATION

PROPOSED  
HIGHWAY PLANS

F.A.P. ROUTE 316 (IL 26)  
SECTION (116 BR)I  
PROJECT:  
BRIDGE APPROACH REPLACEMENT  
BUREAU COUNTY

C-93-094-22

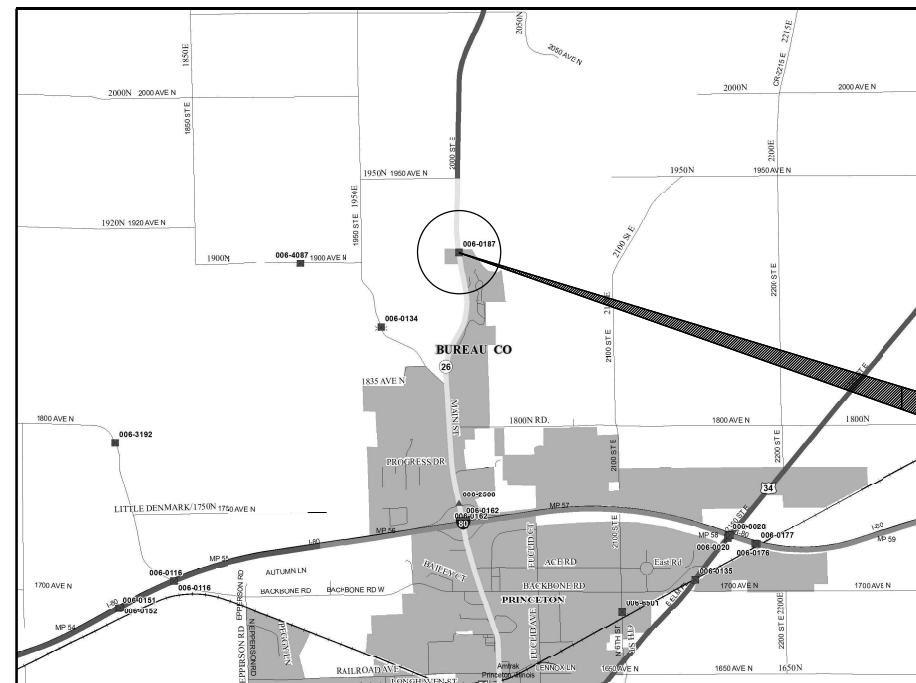

PROJECT LOCATION  
SN 006-0187  
STA 1580+41.5

GROSS LENGTH = 600 FT. = 0.11 MILE  
NET LENGTH = 345 FT. = 0.07 MILE

F.A.P. RTE.	SECTION	COUNTY	TOTAL SHEETS	SHEET NO.
316	(116 BR)I	BUREAU	49	1
		ILLINOIS	CONTRACT NO. 66M70	

D-93-074-22



LOCATION OF SECTION INDICATED THIS: - [Symbol] -

FUNCTION CLASSIFICATION:  
OTHER PRINCIPAL ARTERIAL  
2021 ADT = 3250  
P.V. = 85.8% S.U. = 3.4% M.U. = 10.8%

STATE OF ILLINOIS  
DEPARTMENT OF TRANSPORTATION  
SUBMITTED 02/10 20 23  
*Maood Ahmad* REGIONAL ENGINEER  
March 24, 2023  
*SAE.A. EKS*  
ENGINEER OF DESIGN AND ENVIRONMENT  
March 24, 2023  
*Stephen M. Smith*  
DIRECTOR OF HIGHWAYS PROJECT IMPLEMENTATION

PRINTED BY THE AUTHORITY  
OF THE STATE OF ILLINOIS

GENERAL NOTES

THE THICKNESS OF HMA SHOWN ON THE PLANS IS THE NOMINAL THICKNESS. DEVIATIONS FROM THE NOMINAL THICKNESS WILL BE PERMITTED WHEN SUCH DEVIATIONS OCCUR DUE TO IRREGULARITIES IN THE EXISTING SURFACE OR BASE ON WHICH THE HMA IS PLACED.

EXCEPT AS NOTED ON THE PLANS, PAVEMENT GRADES SHOWN ARE AT THE TOP OF PAVEMENT SURFACES.

THE ENGINEER WILL BE THE SOLE JUDGE CONCERNING CURING TIME FOR THE VARIOUS HMA LIFTS.

SEEDING WILL NOT BE PERMITTED AT ANY TIME WHEN THE GROUND IS FROZEN, WET, OR IN AN UNTILLABLE CONDITION. LOCATIONS TO BE SEEDED WILL BE DETERMINED BY THE ENGINEER.

THE FINISHED EARTHWORK SHALL HAVE A VEGETATION SUSTAINING SOIL COVERING THE TOP FOUR INCHES (100 MILLIMETERS) IN AREAS TO BE SEEDED OR SODDED. THE VEGETATION SUSTAINING SOIL REQUIRED WILL NOT BE PAID FOR SEPARATELY BUT WILL BE INCLUDED IN THE COST OF EARTH EXCAVATION

ALL EXCAVATED MATERIAL, WHICH INCLUDES DIGGING OR GRADING OF ANY SOIL OR FILL MATERIAL, WITH THE EXCEPTION OF AGGREGATE FILLS, MUST BE INCORPORATED WITHIN THE IDOT RIGHT OF WAY.

ALL ELEVATIONS REFERRING TO U.S.G.S. MEAN SEA LEVEL DATUM.

ANY REFERENCE TO A STANDARD IN THESE PLANS SHALL BE INTERPRETED TO MEAN THE EDITION AS INDICATED BY THE SUBNUMBER SHOWN IN THE LIST OF STANDARDS OR THE COPY INCLUDED IN THESE PLANS.

THE FOLLOWING RATES OF APPLICATION HAVE BEEN USED IN CALCULATING PLAN QUANTITIES:

GRANULAR MATERIALS	2.05	TONS / CU YD
HMA RESURFACING	112	LBS / SQ YD / IN
SHORT TERM PAVEMENT MARKING	10	FT /100 FT OF APPLICATION
MIX FOR CRACKS, JTS & FLGWYS	0.0003	TONS / SQ YD
BINDER (HAND METHOD)	0.0005	TONS / SQ YD

THE CONTRACTOR SHALL CONTACT JULIE AT LEAST 48 HOURS PRIOR TO EXCAVATION TO DETERMINE WHICH UTILITIES ARE IN THE AREA.

COMMITMENTS:

1. A FEDERALLY PROTECTED WETLAND EXISTS IN THE NORTHWEST QUADRANT FROM STATION 1572+00 TO STATION 1576+00. CONTRACTOR IS INSTRUCTED TO KEEP ALL ACTIVITY OUTSIDE OF THIS AREA SEE EROSION CONTROL SHEETS FOR LOCATIONS

HMA MIXTURE REQUIREMENT TABLE				
LOCATION(S):	ENTIRE PROJECT	ENTIRE PROJECT	ENTIRE PROJECT	ENTIRE PROJECT
MIXTURE USE(S):	HMA BINDER	HMA SURFACE	HMA SHOULDER BOTTOM LIFT(S)	HMA SHOULDER
BINDER GRADE (PG):	PG 64-22	PG 64-22	PG 64-22	PG 64-22
DESIGN AIR VOIDS:	4.0% @ N50	4.0% @ N50	4.0% @ N50	4.0% @ N50
MIXTURE COMPOSITION: (MIXTURE GRADATION)	IL 9.5FG	IL 9.5	IL 19.0	IL 9.5
FRICTION AGGREGATE:	NA	MIXTURE C	NA	NA
MIXTURE WEIGHT:	112.0 LB/SY/IN	112.0 LB/SY/IN	112.0 LB/SY/IN	112.0 LB/SY/IN
QUALITY MANAGEMENT PROGRAM:	QCQA	QCQA	QCQA	QCQA
SUBLOT SIZE:	NA	NA	NA	NA
DENSITY TEST METHOD:	CORES	CORES	CORES	CORES

STATE OF ILLINOIS  
DEPARTMENT OF TRANSPORTATION  
DISTRICT THREE  
AS BUILT INFORMATION

\_\_\_\_\_  
SUPERVISING CONSTRUCTION FIELD ENGINEER

\_\_\_\_\_  
RESIDENT ENGINEER / TECHNICIAN

START & END DATES  
OF CONSTRUCTION: \_\_\_\_\_

INSPECTORS: \_\_\_\_\_

MODEL: D:\data\...  
 FILE NAME: ...

CODE NO.	ITEM	UNIT	TOTAL QUANTITY	CONSTR. CODE
				100% STATE
				BRIDGE
				0013
				S.N. 006-0187
20200100	EARTH EXCAVATION	CU YD	14.1	14.1
20400800	FURNISHED EXCAVATION	CU YD	13.1	13.1
25000210	SEEDING, CLASS 2A	ACRE	0.4	0.4
25000400	NITROGEN FERTILIZER NUTRIENT	POUND	28	28
25000500	PHOSPHORUS FERTILIZER NUTRIENT	POUND	28	28
25000600	POTASSIUM FERTILIZER NUTRIENT	POUND	28	28
25100630	EROSION CONTROL BLANKET	SQ YD	1461	1461
28000250	TEMPORARY EROSION CONTROL SEEDING	POUND	50	50
28000305	TEMPORARY DITCH CHECKS	FOOT	40	40
28000400	PERIMETER EROSION BARRIER	FOOT	1035	1035
28100805	STONE DUMPED RIPRAP, CLASS A3	TON	28	28
28200200	FILTER FABRIC	SQ YD	88	88
31101000	SUBBASE GRANULAR MATERIAL, TYPE B	TON	102	102
40600290	BITUMINOUS MATERIALS (TACK COAT)	POUND	781	781

USER NAME = Anthony.Grunstad	DESIGNED - _____	REVISED - _____
PLOT SCALE = 100,000' / in.	DRAWN - _____	REVISED - _____
PLOT DATE = 2/10/23	CHECKED - _____	REVISED - _____
	DATE - _____	REVISED - _____

**STATE OF ILLINOIS**  
**DEPARTMENT OF TRANSPORTATION**

**SUMMARY OF QUANTITIES**

SCALE: \_\_\_\_\_ SHEET \_\_\_\_\_ OF \_\_\_\_\_ SHEETS STA. \_\_\_\_\_ TO STA. \_\_\_\_\_

F.A.P. RTE.	SECTION	COUNTY	TOTAL SHEETS	SHEET NO.
316	(116BR)I		49	3
			CONTRACT NO. 66M70	
Long Section Number		ILLINOIS FED. AID PROJECT		

MODEL: D:\data\...  
 FILE NAME: ...

CODE NO.	ITEM	UNIT	TOTAL QUANTITY	CONSTR. CODE
				100% STATE
				BRIDGE
				0013
				S.N. 006-0187
40600370	LONGITUDINAL JOINT SEALANT	FOOT	250	250
40600400	MIXTURE FOR CRACKS, JOINTS, AND FLANGEWAYS	TON	2	2
40600990	TEMPORARY RAMP	SQ YD	53	53
40602965	HOT-MIX ASPHALT BINDER COURSE, IL-9.5FG, N50	TON	105	105
40604050	HOT-MIX ASPHALT SURFACE COURSE, IL-9.5, MIX "C", N50	TON	97	97
42000080	PAVEMENT CONNECTOR (PCC) FOR BRIDGE APPROACH SLAB	SQ YD	164	164
44000100	PAVEMENT REMOVAL	SQ YD	163.5	163.5
44004250	PAVED SHOULDER REMOVAL	SQ YD	44.6	44.6
48203033	HOT-MIX ASPHALT SHOULDERS, 9"	SQ YD	101.6	101.6
50102400	CONCRETE REMOVAL	CU YD	33.4	33.4
50300225	CONCRETE STRUCTURES	CU YD	26.3	26.3
50300255	CONCRETE SUPERSTRUCTURE	CU YD	6.7	6.7
50300260	BRIDGE DECK GROOVING	SQ YD	254	254
50300300	PROTECTIVE COAT	SQ YD	300	300

USER NAME = Anthony.Grunstad	DESIGNED - _____	REVISED - _____	<b>STATE OF ILLINOIS DEPARTMENT OF TRANSPORTATION</b>	<b>SUMMARY OF QUANTITIES</b>		F.A.P. RTE.	SECTION	COUNTY	TOTAL SHEETS	SHEET NO.
PLOT SCALE = 100,000' / in.	DRAWN - _____	REVISED - _____				316	(116BR)I	BUREAU	49	4
PLOT DATE = 2/10/23	CHECKED - _____	REVISED - _____		SCALE: _____ SHEET _____ OF _____ SHEETS STA. _____ TO STA. _____		ILLINOIS FED. AID PROJECT		CONTRACT NO. 66M70		
	DATE - _____	REVISED - _____				Long Section Number				

MODEL: D:\h...  
 FILE NAME: ...

CODE NO.	ITEM	UNIT	TOTAL QUANTITY	CONSTR. CODE
				100% STATE
				BRIDGE
				0013
				S.N. 006-0187
50301350	CONCRETE SUPERSTRUCTURE (APPROACH SLAB)	CU YD	118.1	118.1
50800205	REINFORCEMENT BARS, EPOXY COATED	POUND	48810	48810
50800515	BAR SPLICERS	EACH	292	292
63301210	REMOVE AND REERECT STEEL PLATE BEAM GUARDRAIL, TYPE A	FOOT	12.5	12.5
63301990	REMOVE AND REERECT TRAFFIC BARRIER TERMINALS, TYPE 1	EACH	4	4
63302700	REMOVE AND REERECT TRAFFIC BARRIER TERMINALS, TYPE 6	EACH	4	4
66700205	PERMANENT SURVEY MARKERS, TYPE I	EACH	1	1
67000400	ENGINEER'S FIELD OFFICE, TYPE A	CAL MO	4	4
67100100	MOBILIZATION	L SUM	1	1
70100405	TRAFFIC CONTROL AND PROTECTION, STANDARD 701321	EACH	1	1
70100460	TRAFFIC CONTROL AND PROTECTION, STANDARD 701306	L SUM	1	1
70106500	TEMPORARY BRIDGE TRAFFIC SIGNALS	EACH	1	1
70106700	TEMPORARY RUMBLE STRIPS	EACH	6	6
70300100	SHORT TERM PAVEMENT MARKING	FOOT	355	355
70300150	SHORT TERM PAVEMENT MARKING REMOVAL	SQ FT	118	118

USER NAME = Anthony.Grunstad	DESIGNED - _____	REVISED - _____	<b>STATE OF ILLINOIS DEPARTMENT OF TRANSPORTATION</b>	<b>SUMMARY OF QUANTITIES</b>			F.A.P. RTE.	SECTION	COUNTY	TOTAL SHEETS	SHEET NO.
PLOT SCALE = 100,000' / in.	DRAWN - _____	REVISED - _____					316	(116BR)I	BUREAU	49	5
PLOT DATE = 2/10/23	CHECKED - _____	REVISED - _____		SCALE: _____ SHEET _____ OF _____ SHEETS STA. _____ TO STA. _____			ILLINOIS FED. AID PROJECT		CONTRACT NO. 66M70		
	DATE - _____	REVISED - _____					Long Section Number				

MODEL: D:\data\...  
 FILE NAME: ...

CODE NO.	ITEM	UNIT	TOTAL QUANTITY	CONSTR. CODE
				100% STATE
				BRIDGE
				0013
				S.N. 006-0187
70400100	TEMPORARY CONCRETE BARRIER	FOOT	675	675
70400200	RELOCATE TEMPORARY CONCRETE BARRIER	FOOT	675	675
70600250	IMPACT ATTENUATORS, TEMPORARY (NON- REDIRECTIVE), TEST LEVEL 3	EACH	2	2
70600350	IMPACT ATTENUATORS, RELOCATE (NON- REDIRECTIVE), TEST LEVEL 3	EACH	2	2
* 78009004	MODIFIED URETHANE PAVEMENT MARKING - LINE 4"	FOOT	6738	6738
* 78009006	MODIFIED URETHANE PAVEMENT MARKING - LINE 6"	FOOT	500	500
* 78100100	RAISED REFLECTIVE PAVEMENT MARKER	EACH	23	23
78300200	RAISED REFLECTIVE PAVEMENT MARKER REMOVAL	EACH	23	23
78300202	PAVEMENT MARKING REMOVAL - WATER BLASTING	SQ FT	1895	1895
X4401198	HOT-MIX ASPHALT SURFACE REMOVAL, VARIABLE DEPTH	SQ YD	1184	1184
X6350204	LINEAR DELINEATOR PANELS, 4 INCH	EACH	4	4
Z0004552	APPROACH SLAB REMOVAL	SQ YD	284	284
Z0013798	CONSTRUCTION LAYOUT	L SUM	1	1
Z0030850	TEMPORARY INFORMATION SIGNING	SQ FT	42	42

\* = SPECIALTY ITEM

USER NAME = Anthony.Grunstad PLOT SCALE = 100,000' / in. PLOT DATE = 2/10/23	DESIGNED - _____ DRAWN - _____ CHECKED - _____ DATE - _____	REVISED - _____ REVISED - _____ REVISED - _____ REVISED - _____	<b>STATE OF ILLINOIS</b> <b>DEPARTMENT OF TRANSPORTATION</b>	<b>SUMMARY OF QUANTITIES</b>	F.A.P. RTE. 316 SECTION (116BR)I COUNTY BUREAU TOTAL SHEETS 49 SHEET NO. 6 CONTRACT NO. 66M70	SCALE: _____ SHEET _____ OF _____ SHEETS STA. _____ TO STA. _____	ILLINOIS FED. AID PROJECT Long Section Number
--	--	--	---	------------------------------	--	---	--

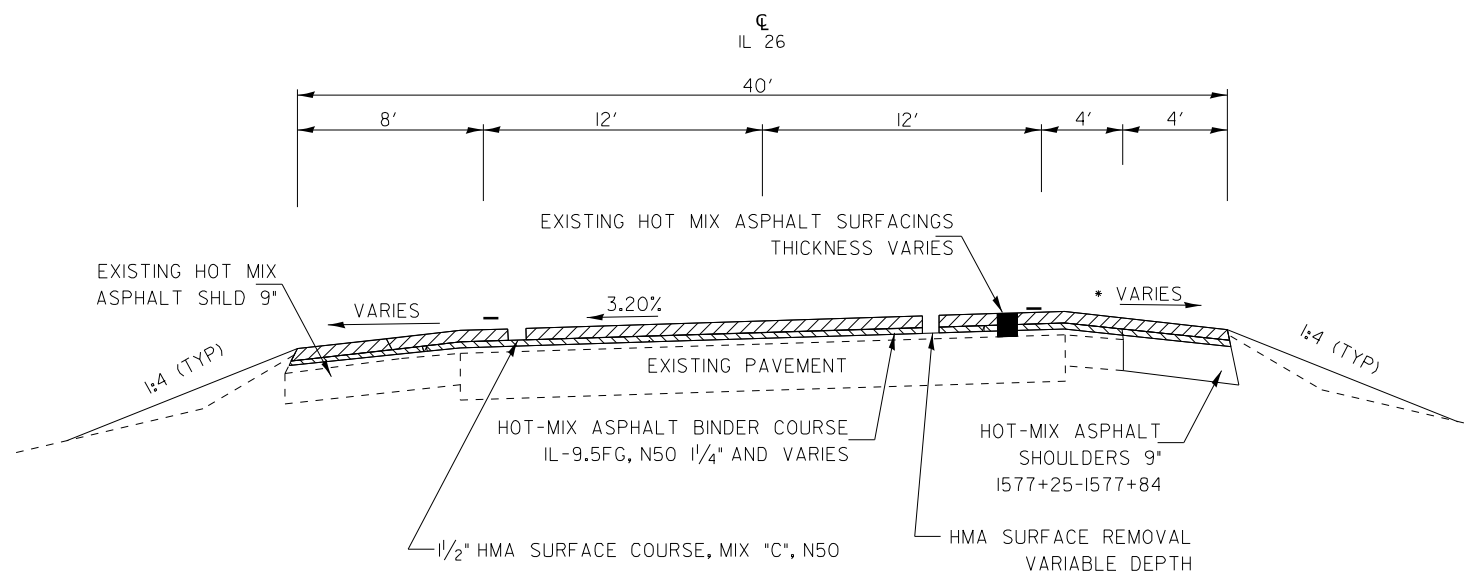

TYPICAL SECTION  
 STA 1577+25 TO STA 1577+84  
 NORTH OF STRUCTURE

\* TRANSITION SHOULDER FROM -4% AT STA. 1577+25 TO -3.2% AT STA. 1578+66.8

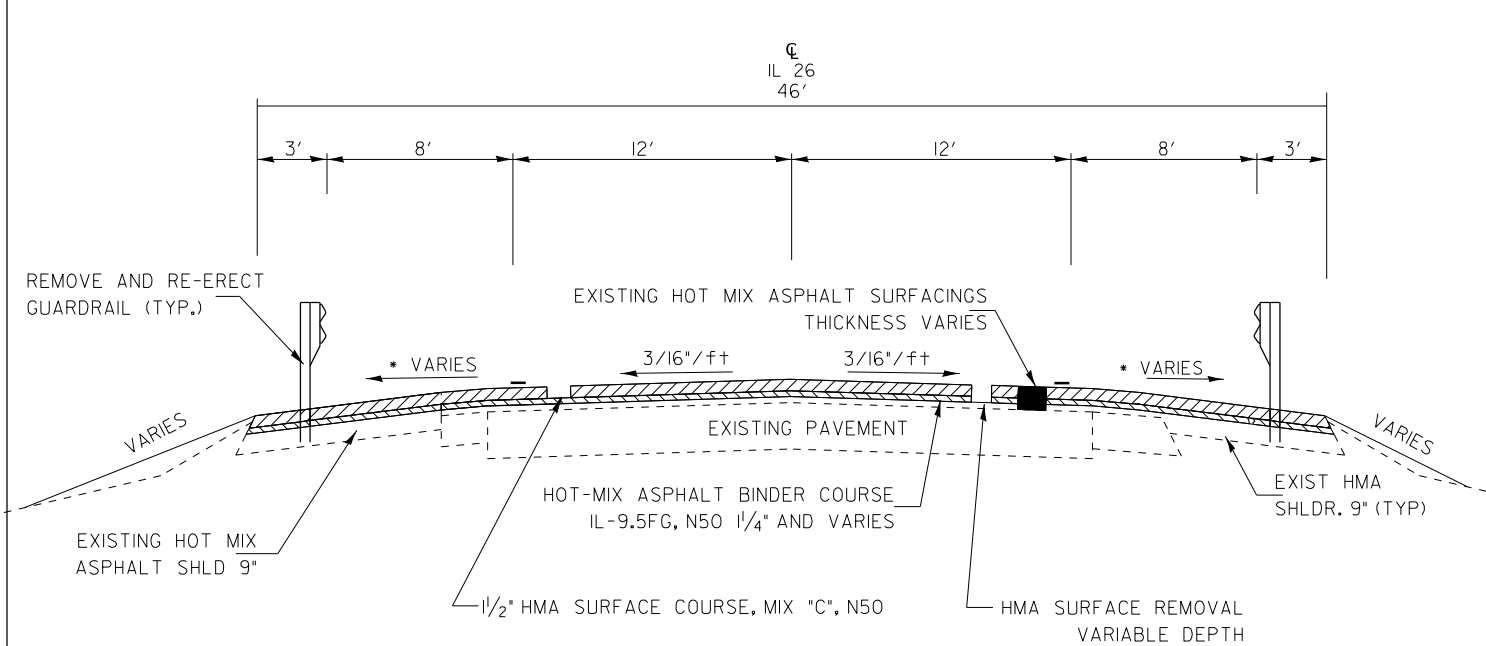

TYPICAL SECTION  
 STA 1581+99 TO STA 1582+95  
 SOUTH OF STRUCTURE

\* TRANSITION SHOULDER FROM -1.5% AT STA. 1581+99 TO -4% AT STA. 1583+25

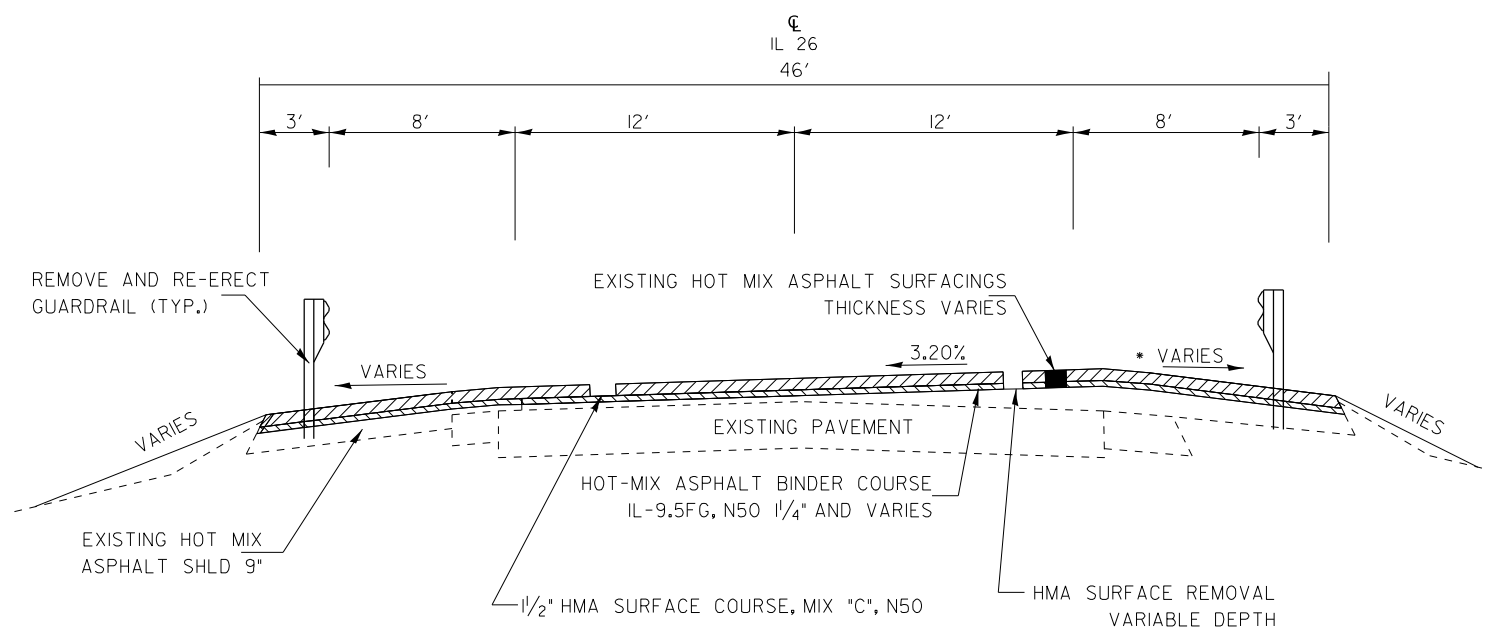

TYPICAL SECTION  
 STA 1577+84 TO STA 1578+66.8  
 NORTH OF STRUCTURE

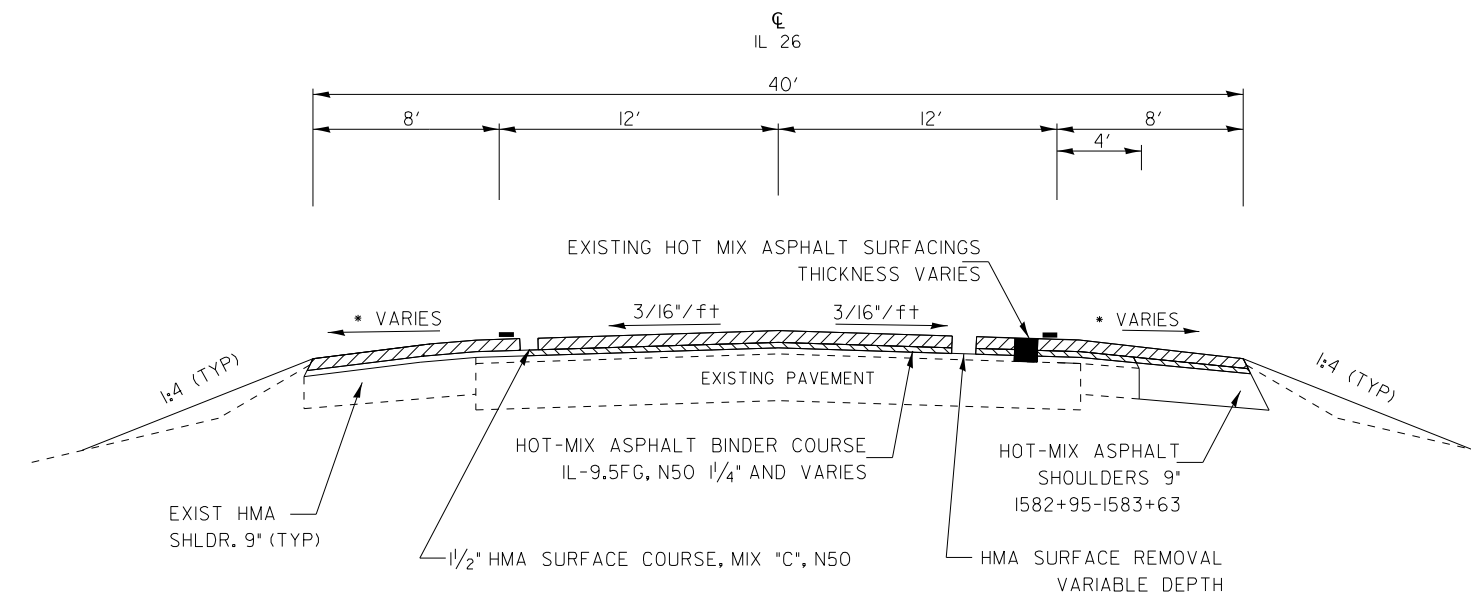

TYPICAL SECTION  
 STA 1582+95 TO STA 1583+25  
 SOUTH OF STRUCTURE

FILE NAME =	USER NAME = Troy.Hart	DESIGNED -	REVISED -
p:\dot-pw.bentley.com\PI\DOT\Documents\IDOT Offices\District 3\ORD Projects\036670\Drawings\CADsheets\036670-shr-realtyp		DRAWN -	REVISED -
Default	PLOT SCALE = 100.000' / in.	CHECKED -	REVISED -
	PLOT DATE = 2/10/2023	DATE -	REVISED -

STATE OF ILLINOIS  
 DEPARTMENT OF TRANSPORTATION

TYPICAL SECTIONS			
SCALE:	SHEET	OF SHEETS	STA. TO STA.

F.A.P. RTE.	SECTION	COUNTY	TOTAL SHEETS	SHEET NO.
316	(116 BR)	BUREAU	49	7
CONTRACT NO. 66M70				
ILLINOIS FED. AID PROJECT				

TRAFFIC STAGING								
LOCATION		TEMPORARY CONCRETE BARRIER	TEMP CONC BARRIER RELOCATE	IMPACT ATTN TL 3 (TEMPORARY)	RELOCATE IMPACT ATTN IL3	TEMPORARY TRAFFIC SIGNALS	TEMPORARY INFORMATION SIGNING	TEMPORARY RUMBLE STRIPS
STA.	STA.	FOOT	FOOT	EACH	EACH	L SUM	SQ FT	EACH
STAGE 1								
1577+22	1583+97	675.0		2		0.5	21	6
STAGE 2								
1577+22	1583+97		675.0		2	0.5	21	
TOTAL		675.0	675.0	2.0	2.0	1.0	42.0	6.0

HOT-MIX ASPHALT SHOULDERS					
LOCATION				EARTH EXCAVATION	HOT-MIX ASPHALT SHOULDER 9"
STA.	STA.	OFFSET	WIDTH	CU YD	SQ YD
PRESTAGE					
1577+25	1577+84	RIGHT	4	6.6	26
1582+95	1583+63	RIGHT	4	7.6	30
TOTAL				14.1	57

\* ALL EARTH EXC TO BE DISPOSED ON FORESLOPE  
STA. 1578+85 TO 1579+15 RT

ROADWAY REMOVAL SCHEDULE										
FROM STATION	TO STATION	WIDTH	HMA SURFACE REMOVAL	PAVEMENT REMOVAL	APPROACH SLAB REMOVAL	CONCRETE REMOVAL		PAVED SHOULDER REM (HMA)	PAVED SHOULDER REM (PCC)	TEMPORARY RAMP
			VAR. DEPTH			(SUB STR)	(SUPER STR)			
			SQ YD	SQ YD	SQ YD	CU YD	CU YD	SQ YD	SQ YD	SQ YD
1577+25.00	1578+66.80	VARIES	652							13.25
1578+66.80	1578+85.04	40		81.2				6.1	6.1	
1578+85.04	1579+15.00	VARIES			142	13.15	3.55	5	5	13.25
1581+68.00	1581+98.00	VARIES			142	13.15	3.55	5	5	13.25
1581+98.00	1582+16.50	40		82.3				6.2	6.2	
1582+16.50	1583+25.00	VARIES	532							13.25
TOTAL			1184	163.5	284	33.4		44.6		53

MODEL: D:\h111...  
 FILE NAME: ...  
 PROJECT: ...  
 DATE: 2/10/2023

USER NAME = Troy.Hart	DESIGNED -	REVISED -	<b>STATE OF ILLINOIS DEPARTMENT OF TRANSPORTATION</b>	<b>SCHEDULES</b>				F.A.P. RTE. 316	SECTION (116BR)I	COUNTY	TOTAL SHEETS 49	SHEET NO. 8
PLOT SCALE = 100,000' / in.	DRAWN -	REVISED -		SCALE:	SHEET	OF	SHEETS	STA.	TO STA.	CONTRACT NO. 66M70		
PLOT DATE = 2/10/2023	CHECKED -	REVISED -		ILLINOIS FED. AID PROJECT								
DATE -	DATE -	REVISED -		Long Section Number								



## ROADWAY PAVEMENT SCHEDULE

FROM STATION	TO STATION	AREA SQ FT	BITUMINOUS MATERIALS (TACK COAT)	HOT-MIX ASPHALT BINDER COURSE IL-9.5 FG, N50	HOT-MIX ASPHALT SURFACE COURSE IL-9.5, N50	LONGITUDINAL JOINT SEAL	MIXTURE FOR CRACKS, JOINTS, AND FLANGWAYS	SUBBASE GRANULAR MATERIAL TYPE B	PAVEMENT CONNECTOR PCC
			POUND	TON	TON	FOOT	TON	TON	SQ YD
1577+25.00	1578+66.80	5625	422	49	53	142	1		
1578+66.80	1578+85.04	730.8						18.5	81.2
1578+85.04	1579+15.00	1278						32.4	
1581+68.00	1581+98.00	1278						32.4	
1581+98.00	1582+16.50	740.7						18.8	82.3
1582+16.50	1583+25.00	4786	359	56	45	109	1		
TOTAL			781	105	97	250	2	102	164

## GUARDRAIL

LOCATION	REMOVE AND RE ERCT	REMOVE AND RE ERCT	REMOVE AND RE ERCT	HMA SHOULDER 9"	LINEAR DELINEATOR 4"
	TY A GR	TBT TY 1	TBT TY 6		
	FOOT	EACH	EACH	SQ YD	EACH
NW QUAD		1	1	11.1	1
NE QUAD		1	1	11.1	1
SW QUAD		1	1	11.2	1
SE QUAD	12.5	1	1	11.2	1
TOTAL	12.5	4	4	44.6	4

## LANDSCAPING

LOCATION			AREA	SEEDING CLASS 2A	EROSION CONTROL BLANKET	NITROGEN FERTILIZER NUTRIENT	PHOSPHORUS FERTILIZER NUTRIENT	POTASSIUM FERTILIZER NUTRIENT	PERIMETER EROSION BARRIER	TEMPORARY DITCH CHECKS	TEMPORARY SEED	FILTER FABRIC	STONE DUMPED RR CL 3	FURNISHED EXCAVATION
STA.	STA.	OFFSET	SQ FT	ACRE	SQ YD	POUND	POUND	POUND	FOOT	FOOT	POUND	SQ YD	TON	CU YD
1576+63	1579+19	LEFT	4269.77	0.1	475	9	9	9	255	10	12.5	23	7	11.5
1576+60	1579+09	RIGHT	4665.52	0.1	519	10	10	10	258	10	12.5	22	7	19.9
1581+74	1584+81	LEFT	4196.78	0.1	467	9	9	9	284	10	12.5	19	7	3.7
1581+65	1584+00	RIGHT	4315.61	0.1	480	9	9	9	238	10	12.5	24	7	5
TOTAL				0.4	1461	28	28	28	1035	40	50	88	28	40.1

MODEL: D:\h111...  
 FILE NAME: ...  
 PROJECT: ...  
 DRAWN BY: ...  
 CHECKED BY: ...  
 DATE: 2/10/2023

USER NAME = Troy.Hart	DESIGNED -	REVISED -
	DRAWN -	REVISED -
PLOT SCALE = 100,000' / in.	CHECKED -	REVISED -
PLOT DATE = 2/10/2023	DATE -	REVISED -

**STATE OF ILLINOIS  
DEPARTMENT OF TRANSPORTATION**

**SCHEDULES**

SCALE: SHEET OF SHEETS STA. TO STA.

F.A.P. RTE.	SECTION	COUNTY	TOTAL SHEETS	SHEET NO.
316	(116BR)I	BUREAU	49	9
CONTRACT NO. 66M70				
ILLINOIS FED. AID PROJECT				

Long Section Number

PAVEMENT MARKING SCHEDULE										
LOCATION		MOD URETHANE PAVEMENT MARKING LINE 4" (2 APPLICATIONS)	MOD URETHANE PAVEMENT MARKING LINE 4" (2 APPLICATIONS)	MOD URETHANE PVMT MRKG LINE 6" (2 APPLICATIONS)	RAISED REFLECT PVMT MARK REM	RAISED REFLECT PVMT MARK	PAVEMENT MARKING REMOVAL WATER BLAST	SHORT TERM PVMT MARK	SHORT TERM PVMT MARK REM	
STA.	TO	STA.	LENGTH	FOOT	FOOT	FOOT	EACH	EACH	SQ FT	SQ FT
STAGE 1										
1575+16		1587+00	1184				23		1186	
STAGE 2										
1575+16		1587+00	1184						344	
STAGE 3										
1575+16		1587+00	1184	4736	2002	500		23	365	355 118
TOTAL					6738	500	23	23	1895	355 118

NO PASSING ZONES:  
 NORTHBOUND STATION 1576+21 to 1587+00  
 SOUTHBOUND STATION 1575+16 TO 1578+04

ILL. RTE. 26		LOCATION: BIG BUREAU CREEK, 1.7 MI N OF I-80			BUREAU COUNTY	
MONUMENT NUMBER	DESCRIPTION	EXISTING MONUMENT TYPE	PROPOSED MONUMENT TYPE	MONUMENT RECORD TO BE RECORDED	RESPONSIBILITY	
PT15791460	PT STA 1579+14.60	TYPE 1	TYPE 1	NO	1	
<p>TYPE 1 MONUMENT SET PER CONTRACT 66M70 TO BE REPLACED IN KIND.            UPON PAVEMENT COMPLETION, R.E. WILL DIRECT A PLATS AND PLANS LAND SURVEYOR TO STAKE THE LISTED MONUMENT FOR CORING.            NO MONUMENT RECORDS ARE REQUIRED.</p> <p>NOTE: FOR BIDDING PURPOSES NO CONTRACTED LAND SURVEYING SERVICES WILL BE REQUIRED FOR SETTING THIS MONUMENT.</p> <p>RESPONSIBILITY:            1: RESIDENT TO SET MONUMENT (PAY ITEM REQUIRED. PERMANENT SURVEY MARKER, TYPE 1)            2: PLATS AND PLANS TO SET MONUMENT</p>						

MODEL: D:\data\...  
 FILE NAME: ...

USER NAME = Timothy.Pletsch	DESIGNED - _____	REVISED - _____
PLOT SCALE = 100,000' / in.	DRAWN - _____	REVISED - _____
PLOT DATE = 3/27/2023	CHECKED - _____	REVISED - _____
	DATE - _____	REVISED - _____

**STATE OF ILLINOIS  
DEPARTMENT OF TRANSPORTATION**

SCHEDULES	
SCALE: _____	SHEET _____ OF _____ SHEETS STA. _____ TO STA. _____

F.A.P. RTE. 316	SECTION (116BR)I	COUNTY BUREAU	TOTAL SHEETS 49	SHEET NO. 10
CONTRACT NO. 66M70				
ILLINOIS FED. AID PROJECT				

Long Section Number

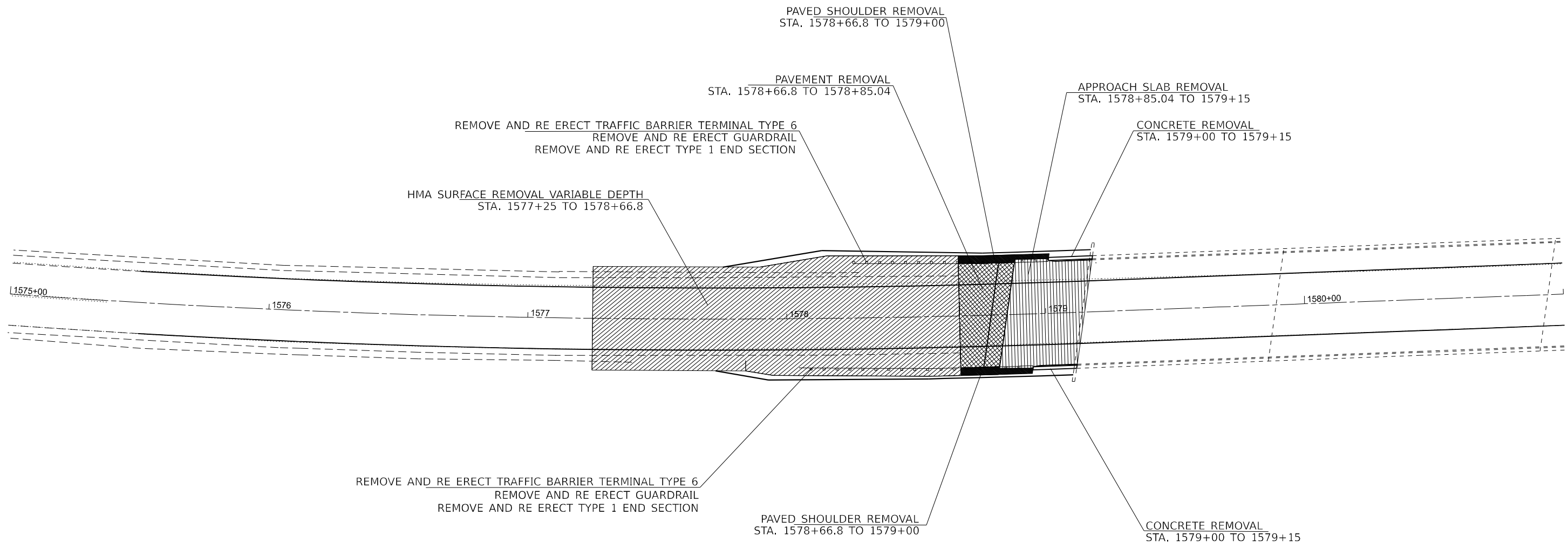

- HMA SURFACE REMOVAL VARIABLE DEPTH
- PAVEMENT REMOVAL
- APPROACH SLAB REMOVAL
- CONCRETE REMOVAL
- PAVED SHOULDER REMOVAL



MODEL: I:\27 - File 1 (Sheet)  
 FILE NAME: P:\MIDOT\Documents\DOT Office\District 3\ORD Project\366M70\CADD\Drawings\366M70 Removal Plans

USER NAME = Troy Hart	DESIGNED -	REVISED -
DRAWN -	REVISIED -	
PLOT SCALE = 0.16666633' / in.	CHECKED -	REVISED -
PLOT DATE = 2/10/2023	DATE -	REVISED -

**STATE OF ILLINOIS  
DEPARTMENT OF TRANSPORTATION**

<b>REMOVAL PLANS</b>			
STA. 1575+00-1581+00			
SCALE: 1"=20'	SHEET PLAN 1	OF SHEETS	STA. TO STA.

F.A.P. RTE. 316	SECTION (116 BR)I	COUNTY	TOTAL SHEETS 49	SHEET NO. 11
CONTRACT NO. 66M70			ILLINOIS FED. AID PROJECT	

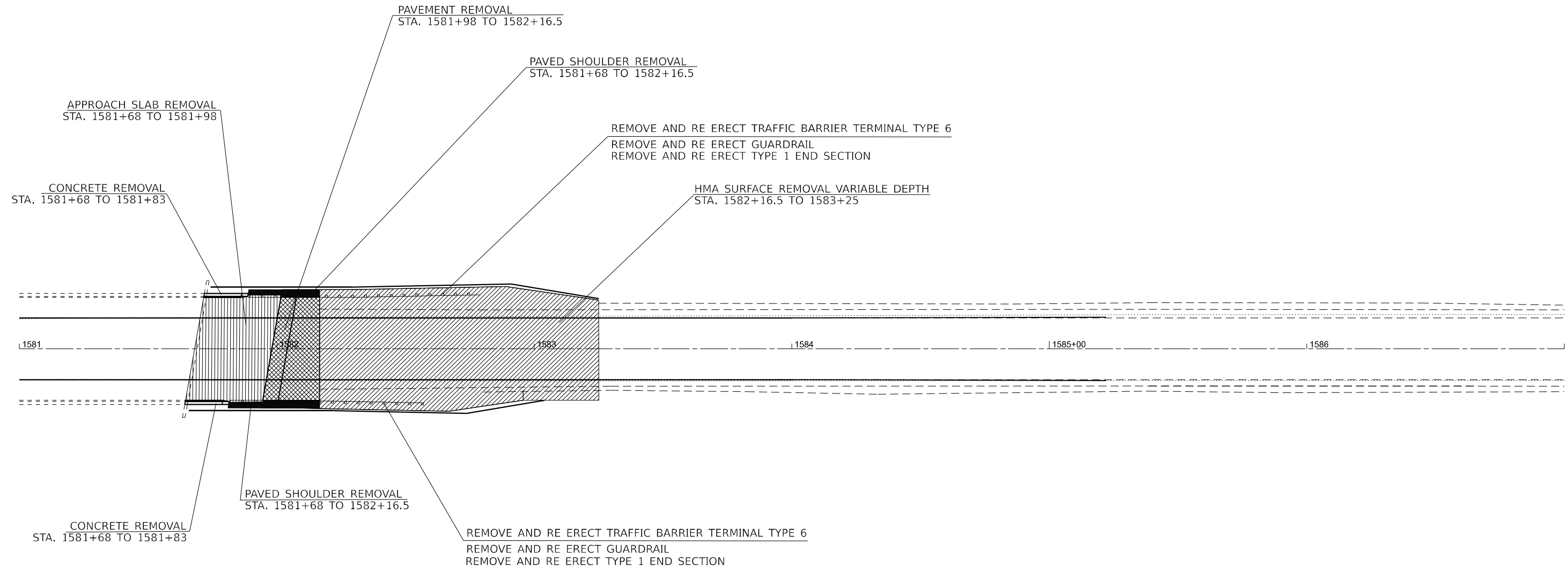
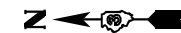

SCALE IN FEET

- HMA SURFACE REMOVAL VARIABLE DEPTH
- PAVEMENT REMOVAL
- APPROACH SLAB REMOVAL
- CONCRETE REMOVAL (APPROACH PARAPET)
- PAVED SHOULDER REMOVAL

MODEL: I:\27 - Files - 2 (Sheet) FILE NAME: P:\MIDOT\Documents\MIDOT Office\District 3\ORIG Projects\366M70\CADD\Drawings\366M70 Removal Plans

USER NAME = Troy Hart	DESIGNED -	REVISED -
DRAWN -	DRAWN -	REVISED -
PLOT SCALE = 0.16666633' / in.	CHECKED -	REVISED -
PLOT DATE = 2/10/2023	DATE -	REVISED -

**STATE OF ILLINOIS**  
**DEPARTMENT OF TRANSPORTATION**

**REMOVAL PLANS**  
**STA. 1581+00 TO 1587+00**

SCALE: 1"=20' SHEET PLAN 2 OF SHEETS STA. TO STA.

F.A.P. RTE. 116	SECTION (116 BR) I	COUNTY	TOTAL SHEETS 49	SHEET NO. 12
			CONTRACT NO. 66M70	
ILLINOIS FED. AID PROJECT				



HMA SURFACE REMOVAL VARIABLE DEPTH  
 HMA BINDER CSE, IL-9.5FG N50 1 1/4" & VARIES  
 HMA SURFACE CSE IL 9.5 MIX "C", N50, 1 1/2"

EX CURVE 0136CL-1  
 PI STA = 1575+49.05  
 $\Delta = 10^{\circ}57'57"$  (LT)  
 $D = 01^{\circ}29'43"$   
 $R = 3,831.70'$   
 $T = 367.80'$   
 $L = 733.35'$   
 $e = 3.20\%$   
 PC STA = 1571+81.25  
 PT STA = 1579+14.60

BEGIN PROJECT  
 STA. 1577+25

S. END OF N APPR. 1579+15.02  
 N. END OF N APPR. 1578+85.04

EXISTING STRUCTURE  
 SN 006-0187

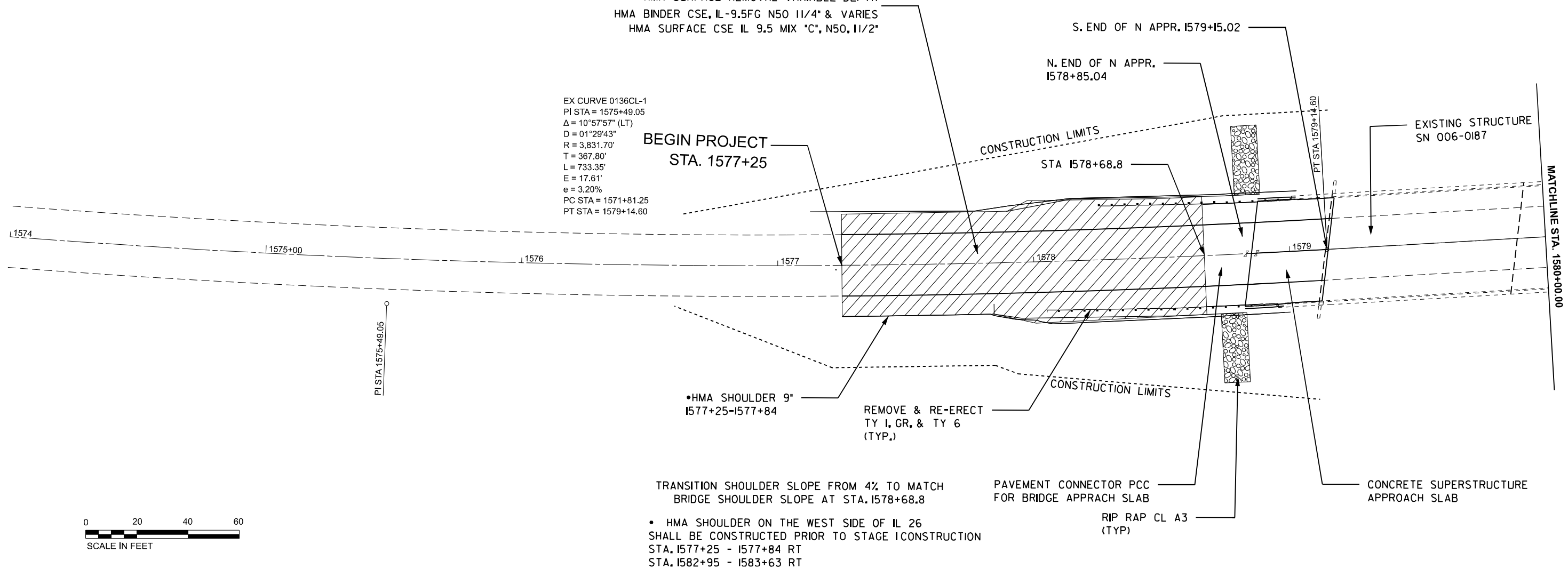

TRANSITION SHOULDER SLOPE FROM 4% TO MATCH  
 BRIDGE SHOULDER SLOPE AT STA. 1578+68.8

- HMA SHOULDER ON THE WEST SIDE OF IL 26  
 SHALL BE CONSTRUCTED PRIOR TO STAGE I CONSTRUCTION  
 STA. 1577+25 - 1577+84 RT  
 STA. 1582+95 - 1583+63 RT

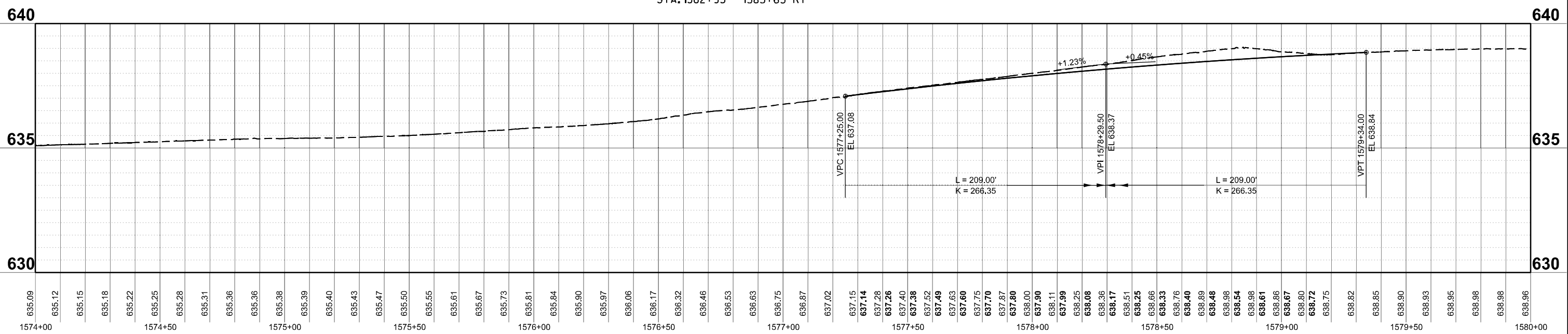

MODEL: sheet 1 of 2  
 FILE NAME: P:\Bids\pcc\mfr\DOT\Documents\DOT Office\Dist13\ORD Projects\368MTP\CAD\Drawings\66M70 PLAN and PROFILE

USER NAME = Anthony.Grunstad	DESIGNED -	REVISED -
DRAWN -	REVISIED -	
PLOT SCALE = 0.16666633' / in.	CHECKED -	REVISED -
PLOT DATE = 2/10/23	DATE -	REVISED -

**STATE OF ILLINOIS  
 DEPARTMENT OF TRANSPORTATION**

**PLAN AND PROFILE  
 STA. 1577+25 TO 1580+00**

SCALE: 1"=20'      SHEET 1 OF 2 SHEETS      STA.      TO STA.

F.A.P. RTE. 316	SECTION (116 BR)	COUNTY BUREAU	TOTAL SHEETS 49	SHEET NO. 13
CONTRACT NO. 66M70				
ILLINOIS FED. AID PROJECT				

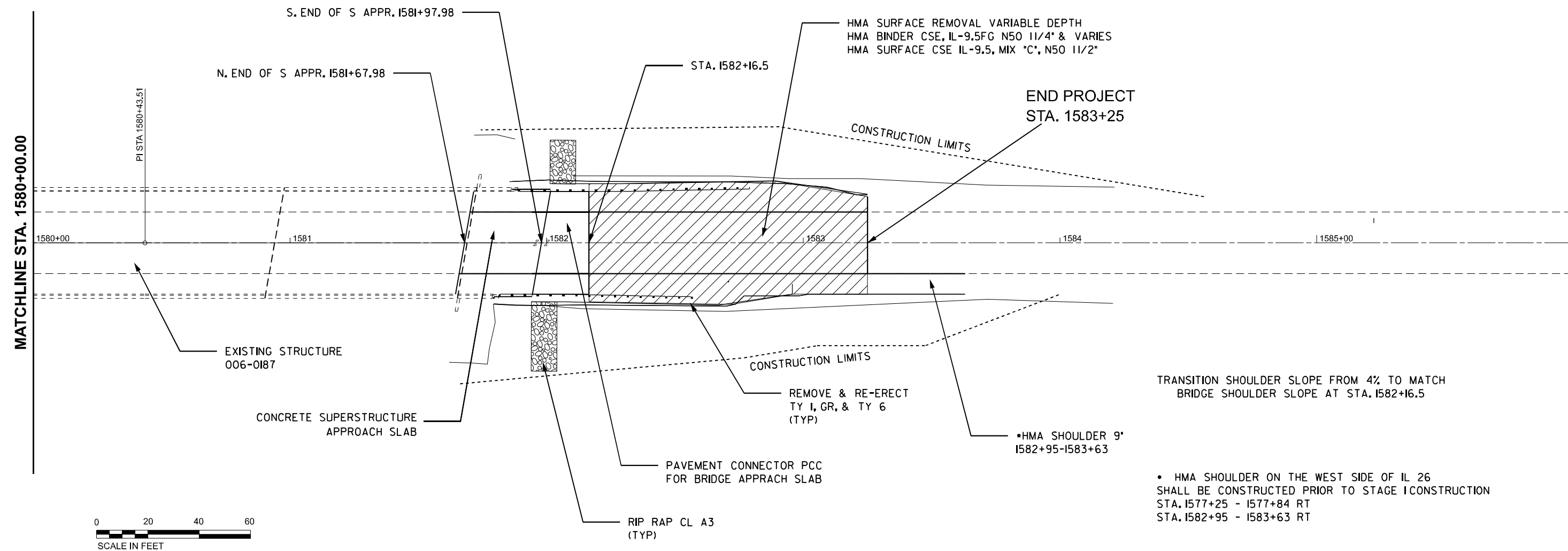

TRANSITION SHOULDER SLOPE FROM 4% TO MATCH BRIDGE SHOULDER SLOPE AT STA. I582+16.5

- HMA SHOULDER ON THE WEST SIDE OF IL 26 SHALL BE CONSTRUCTED PRIOR TO STAGE I CONSTRUCTION STA. I577+25 - I577+84 RT
- STA. I582+95 - I583+63 RT

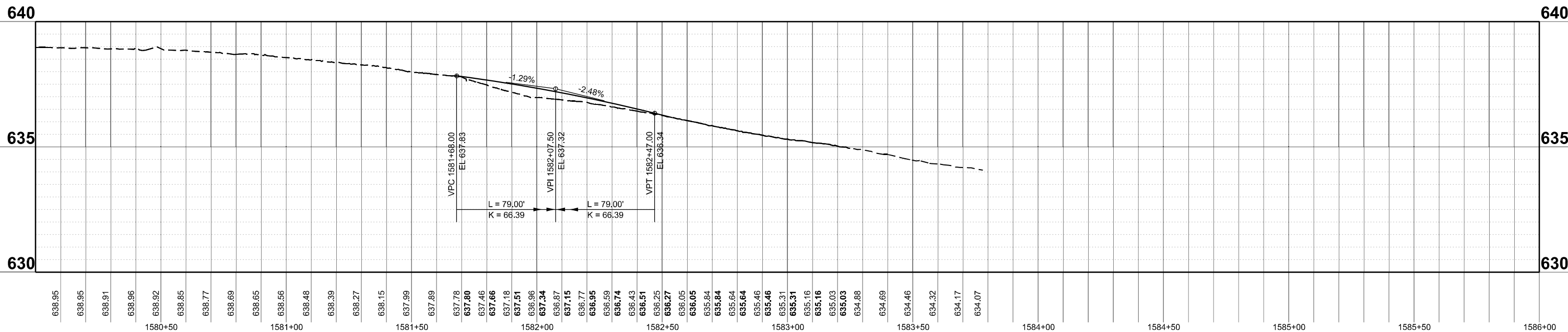

USER NAME = Anthony.Grunstad	DESIGNED -	REVISED -
PLOT SCALE = 0.16666633' / in.	DRAWN -	REVISED -
PLOT DATE = 2/10/23	CHECKED -	REVISED -
	DATE -	REVISED -

**STATE OF ILLINOIS  
DEPARTMENT OF TRANSPORTATION**

**PLAN AND PROFILE  
STA. 1580+00 TO 1583+25**

SCALE: 1"=20' SHEET 2 OF 2 SHEETS STA. TO STA.

F.A.P. RTE. 316	SECTION (116 BR)	COUNTY	TOTAL SHEETS 49	SHEET NO. 14
CONTRACT NO. 66M70			ILLINOIS FED. AID PROJECT	

MODEL: sheet 1 of 1  
 FILE NAME: P:\projects\66m70\DOT\Documents\DOT Office\District 3\ORD Projects\66M70\CADD\Drawings\66M70 PLAN and PROFILE



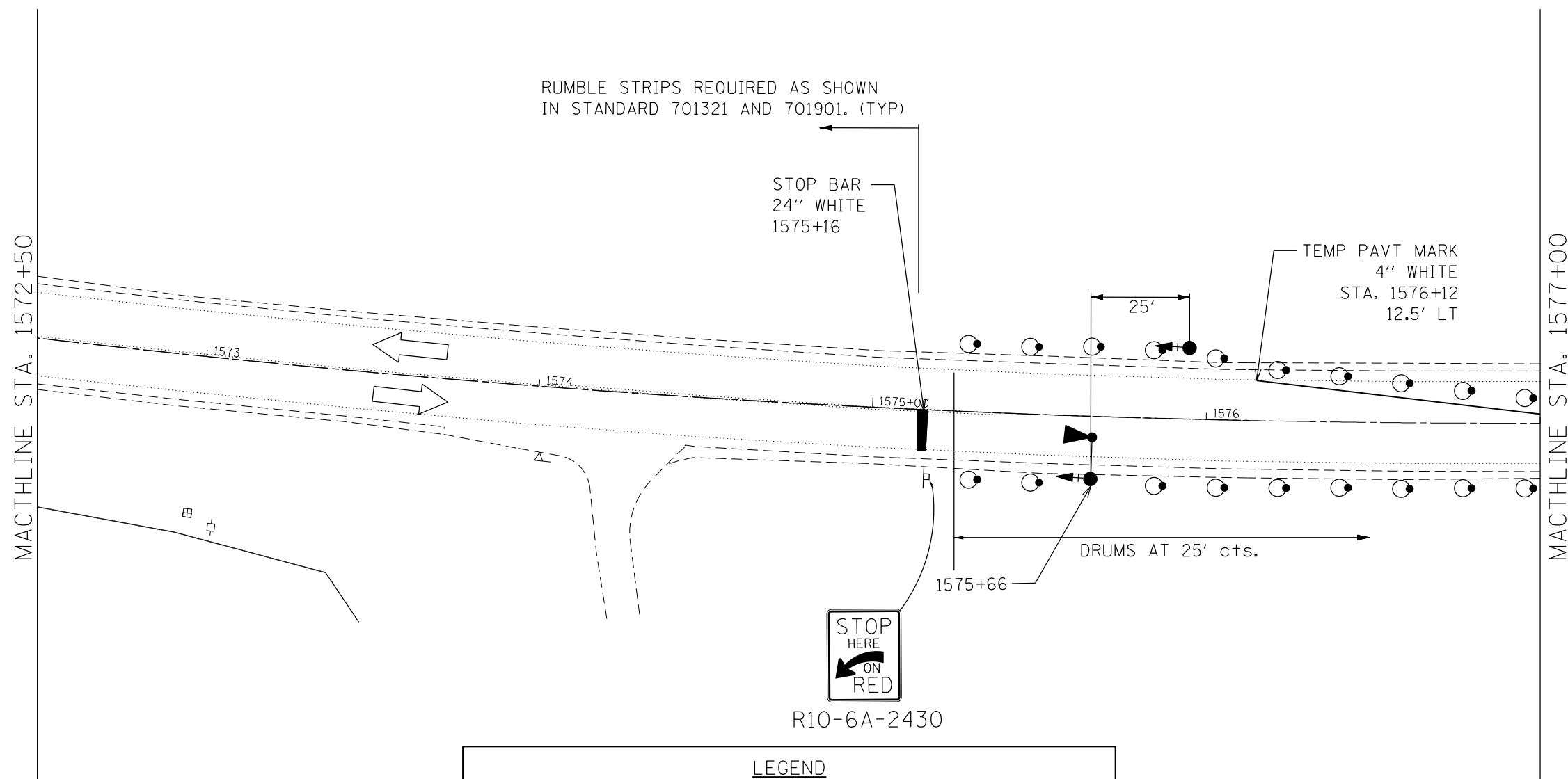

RUMBLE STRIPS REQUIRED AS SHOWN  
IN STANDARD 701321 AND 701901. (TYP)

STOP BAR  
24" WHITE  
1575+16

TEMP PAVT MARK  
4" WHITE  
STA. 1576+12  
12.5' LT

DRUMS AT 25' cts.

R10-6A-2430

LEGEND	
	IMPACT ATTENUATOR
	WORK AREA
	TEMPORARY CONCRETE BARRIER
	DRUM WITH STEADY BURNING LIGHT
	TRAFFIC SIGNAL WITH BACKPLATE
	TYPE III BARRICADE
	MICROWAVE DETECTOR
	VERTICAL PANEL
	SIGN



BARRIER WALL, GUARDRAIL AND  
PARAPET BI DIRECTIONAL REFLECTORS  
TO BE INSTALLED AT 25' CENTERS.

OFFSET TO BARRIER IS ON  
THE WEST SIDE OF THE BARRIER

•REFER TO STANDARD 701321  
FOR DETAILS NOT SHOWN•

FILE NAME =	USER NAME = Troy.Hart	DESIGNED -	REVISED -	<b>STATE OF ILLINOIS DEPARTMENT OF TRANSPORTATION</b>	<b>STAGE 1 CONSTRUCTION</b>				F.A.P. RTE.	SECTION	COUNTY	TOTAL SHEETS	SHEET NO.
Default	pw:\idot-pw.bentley.com\PIDOT\Documents\IDOT Offices\District 3\Projects\0366A19\CDRAWINGS\0366A19-sht-stage construction	CHECKED -	REVISED -		316	[116 BRJ]	BUREAU	49	16				
	PLOT SCALE = 40.0000' / in.	DATE -	REVISED -		CONTRACT NO. 66M70								
	PLOT DATE = 2/9/2023				SCALE:	SHEET	OF	SHEETS	STA.	TO	STA.	ILLINOIS FED. AID PROJECT	



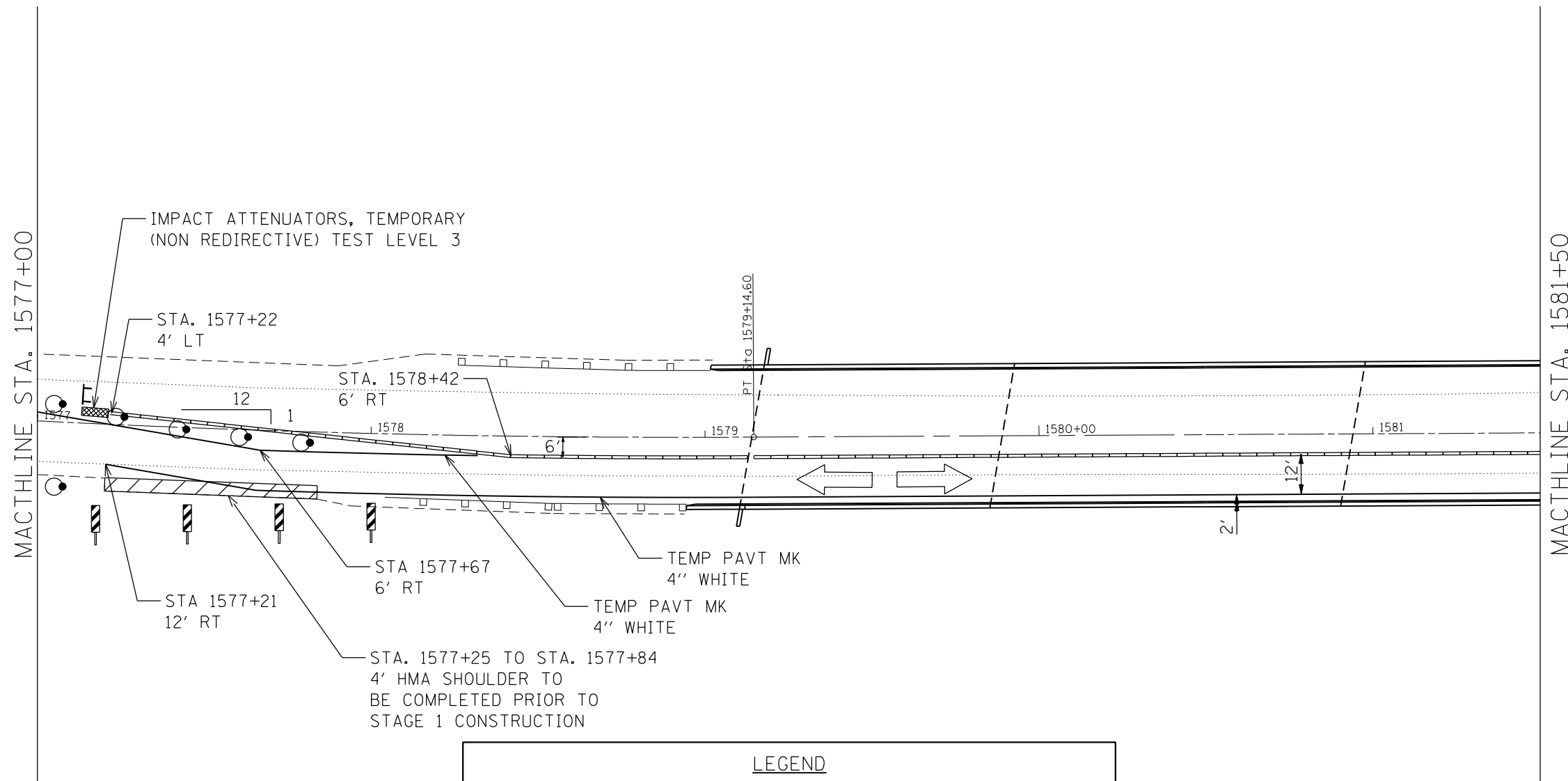

BARRIER WALL, GUARDRAIL AND PARAPET BI DIRECTIONAL REFLECTORS TO BE INSTALLED AT 25' CENTERS.

OFFSET TO BARRIER IS ON THE WEST SIDE OF THE BARRIER

•REFER TO STANDARD 701321 FOR DETAILS NOT SHOWN•

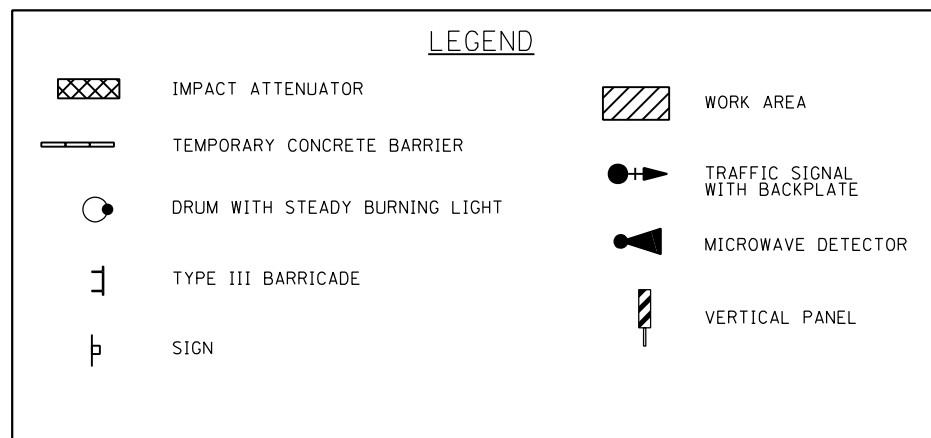

FILE NAME =	USER NAME = Troy.Hart	DESIGNED -	REVISED -
p:\dot-pw.bentley.com\PWIDOT\Documents\DOT Offices\District 3\Projects\0366A19\CDRAWINGS\0366A19-sht-stage construction		REVISOR -	REVISOR -
Default	PLOT SCALE = 40.0000' / in.	CHECKED -	REVISED -
	PLOT DATE = 2/9/2023	DATE -	REVISED -

**STATE OF ILLINOIS  
DEPARTMENT OF TRANSPORTATION**

<b>STAGE 1 CONSTRUCTION</b>			
SCALE:	SHEET	OF SHEETS	STA. TO STA.

F.A.P. RTE.	SECTION	COUNTY	TOTAL SHEETS	SHEET NO.
316	[116 BRJ]	BUREAU	49	17
CONTRACT NO. 66M70				
ILLINOIS FED. AID PROJECT				



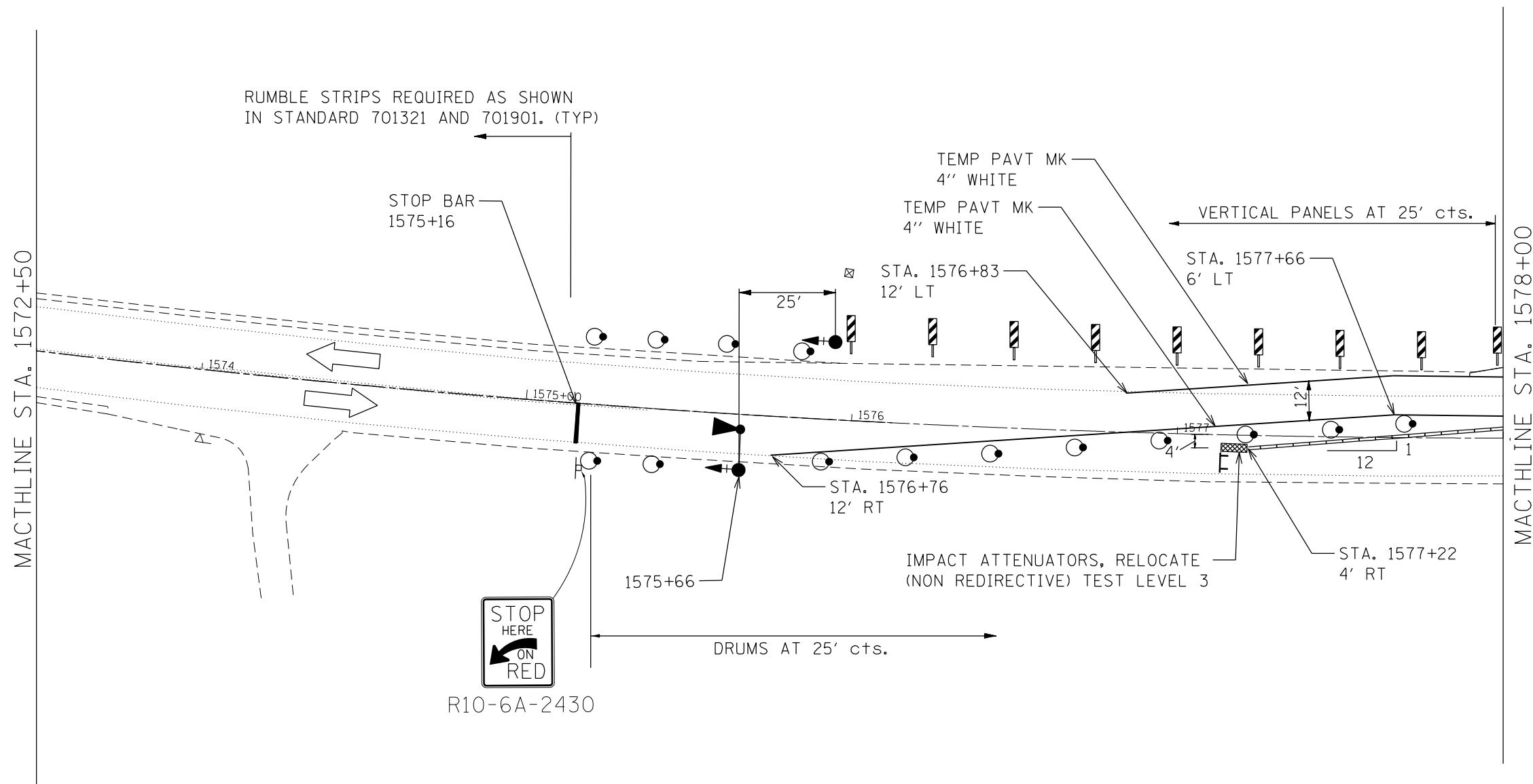
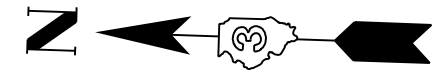

BARRIER WALL, GUARDRAIL AND PARAPET BI DIRECTIONAL REFLECTORS TO BE INSTALLED AT 25' CENTERS.

OFFSET TO BARRIER IS ON THE EAST SIDE OF THE BARRIER

\*REFER TO STANDARD 701321 FOR DETAILS NOT SHOWN\*

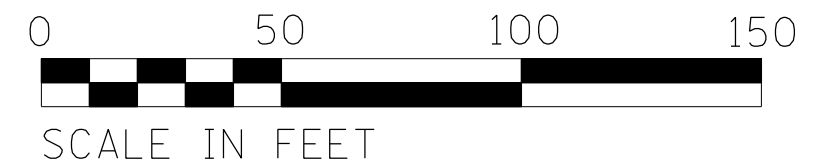
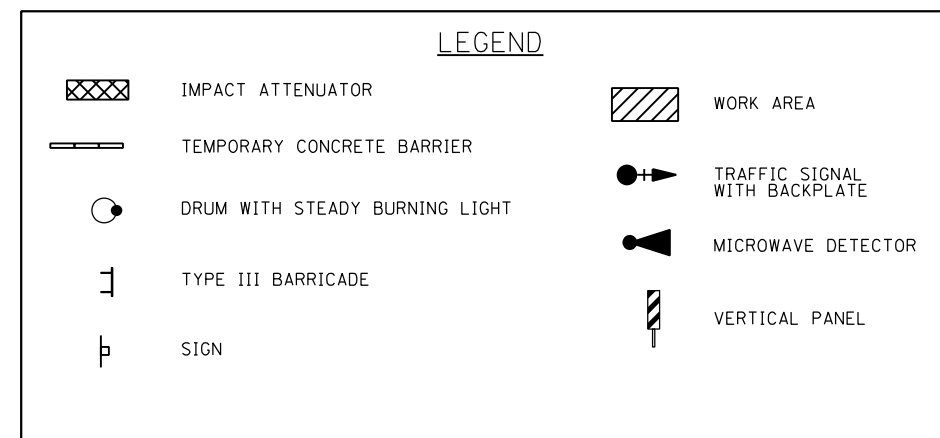

FILE NAME =	USER NAME = Troy.Hart	DESIGNED -	REVISED -
p:\dot-pw.bentley.com\PI\DOT\Documents\DOT Offices\District 3\Projects\0366A19\CDRAWINGS\0366A19-sht-stage construction		REVISIONS	
Default	PLOT SCALE = 40.0000' / in.	CHECKED -	REVISED -
	PLOT DATE = 2/9/2023	DATE -	REVISED -

**STATE OF ILLINOIS  
DEPARTMENT OF TRANSPORTATION**

<b>STAGE 2 CONSTRUCTION</b>			
SCALE:	SHEET	OF SHEETS	STA. TO STA.

F.A.P. RTE.	SECTION	COUNTY	TOTAL SHEETS	SHEET NO.
316	[116 BRJ]	BUREAU	49	19
CONTRACT NO. 66M70			ILLINOIS FED. AID PROJECT	

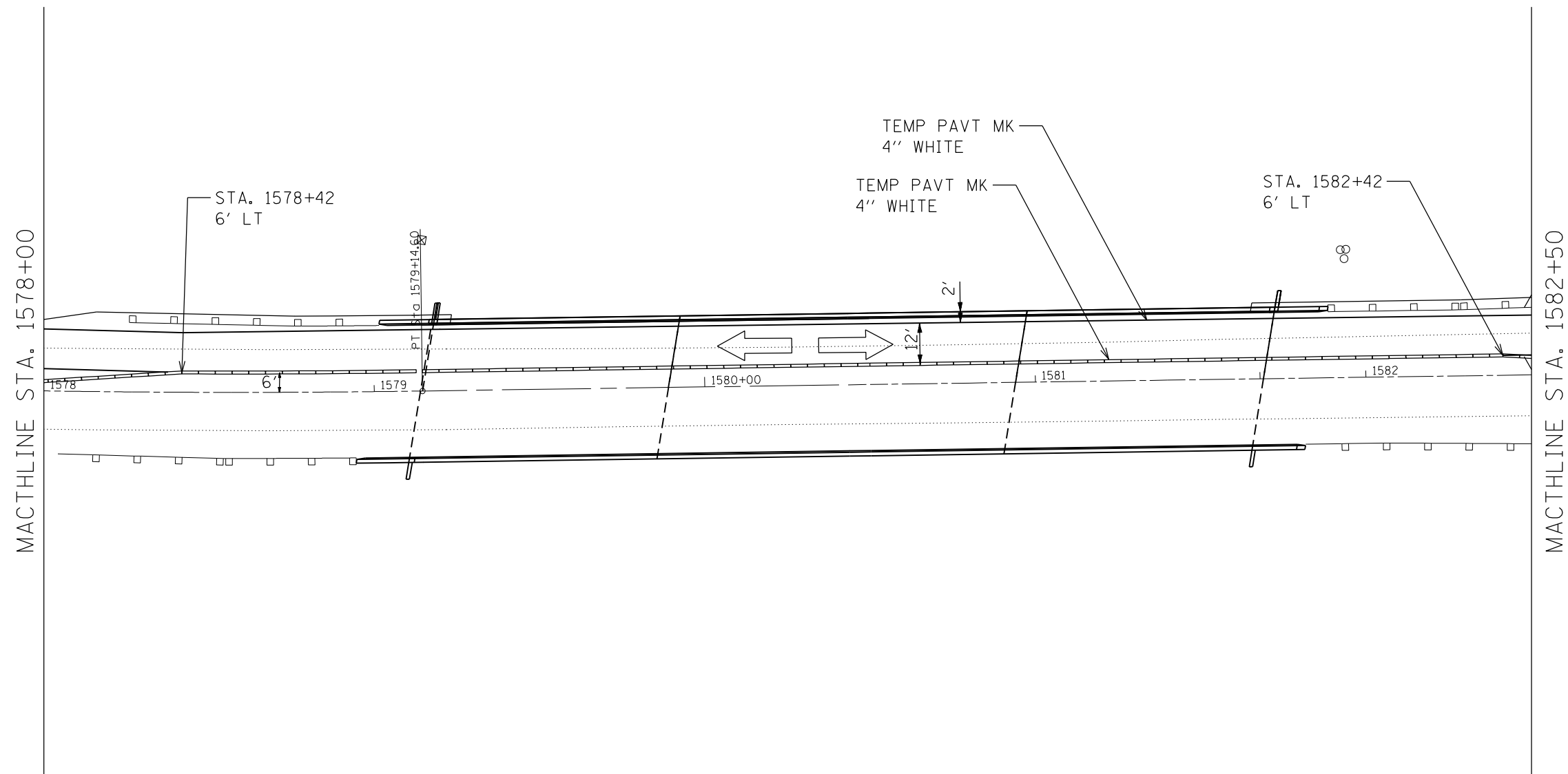
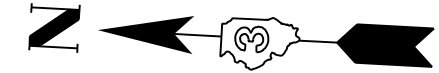

BARRIER WALL, GUARDRAIL AND PARAPET BI DIRECTIONAL REFLECTORS TO BE INSTALLED AT 25' CENTERS.

OFFSET TO BARRIER IS ON THE EAST SIDE OF THE BARRIER

•REFER TO STANDARD 701321 FOR DETAILS NOT SHOWN•

LEGEND	
	IMPACT ATTENUATOR
	WORK AREA
	TEMPORARY CONCRETE BARRIER
	DRUM WITH STEADY BURNING LIGHT
	TRAFFIC SIGNAL WITH BACKPLATE
	TYPE III BARRICADE
	MICROWAVE DETECTOR
	VERTICAL PANEL
	CRYSTAL, BI-DIRECTIONAL GUARDRAIL/BARRIER WALL REFLECTOR
	SIGN

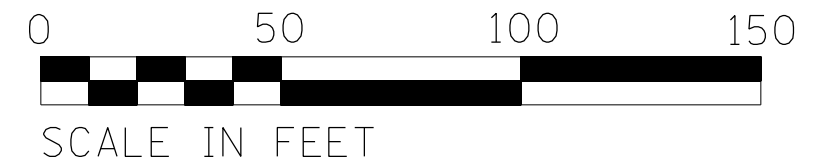

FILE NAME =	USER NAME = TroyHart	DESIGNED -	REVISED -
p:\dot-pw.bentley.com\PIWIDOT\Documents\IDOT Offices\District 3\Projects\0366A19\CDRAWINGS\0366A19-sht-stage constr		REVISIO	
Default	PLOT SCALE = 40.0000' / in.	CHECKED -	REVISED -
	PLOT DATE = 2/9/2023	DATE -	REVISED -

STATE OF ILLINOIS  
DEPARTMENT OF TRANSPORTATION

STAGE 2 CONSTRUCTION			
SCALE:	SHEET	OF SHEETS	STA. TO STA.

F.A.P. RTE.	SECTION	COUNTY	TOTAL SHEETS	SHEET NO.
316	[116 BRJ]	BUREAU	49	20
CONTRACT NO. 66M70				
ILLINOIS FED. AID PROJECT				

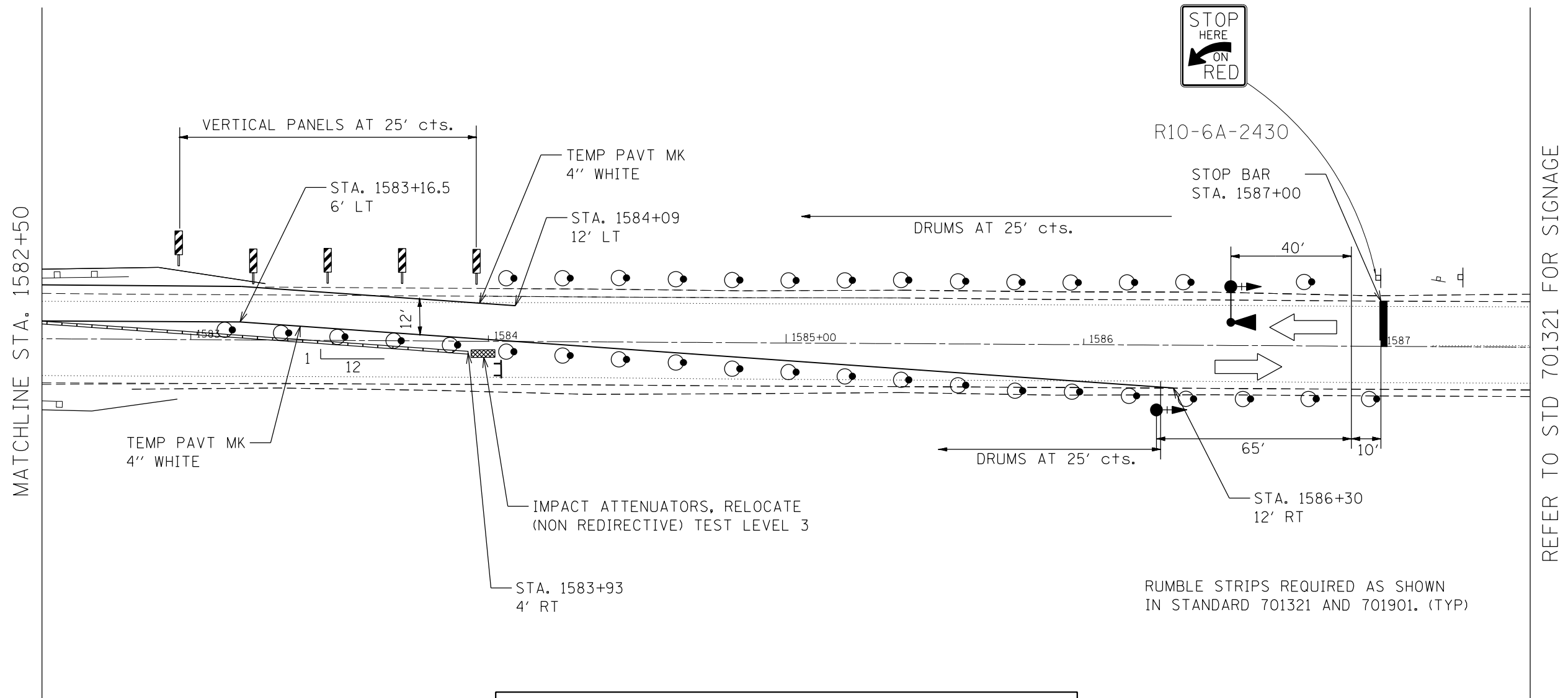
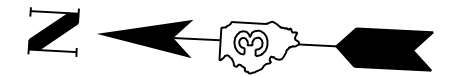

OFFSET TO BARRIER IS ON THE EAST SIDE OF THE BARRIER

•REFER TO STANDARD 701321 FOR DETAILS NOT SHOWN•

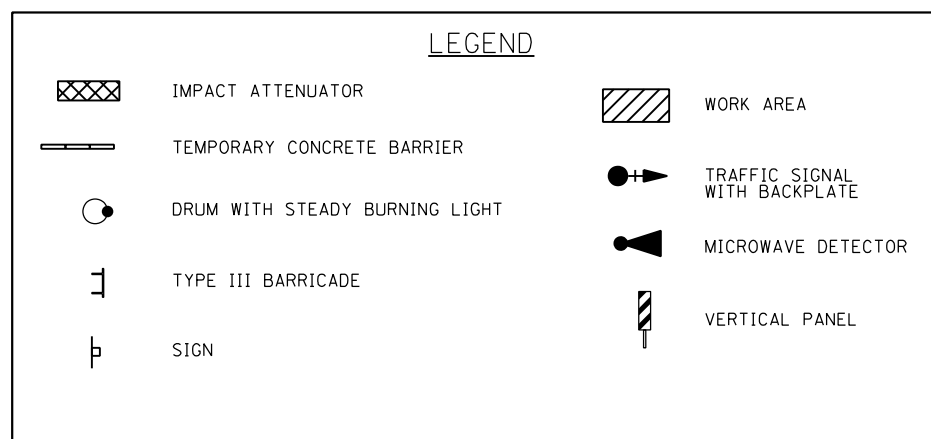





FILE NAME =	USER NAME = Troy.Hart	DESIGNED -	REVISED -	<b>STATE OF ILLINOIS DEPARTMENT OF TRANSPORTATION</b>	<b>STAGE 2 CONSTRUCTION</b>	F.A.P. RTE. 316	SECTION [116 BRJ]	COUNTY BUREAU	TOTAL SHEETS 49	SHEET NO. 21
Default	Plot Scale = 40.0000' / in.	CHECKED -	REVISED -		SCALE:					
	PLOT DATE = 2/9/2023	DATE -	REVISED -		SHEET OF SHEETS	STA. TO STA.			ILLINOIS FED. AID PROJECT CONTRACT NO. 66M70	

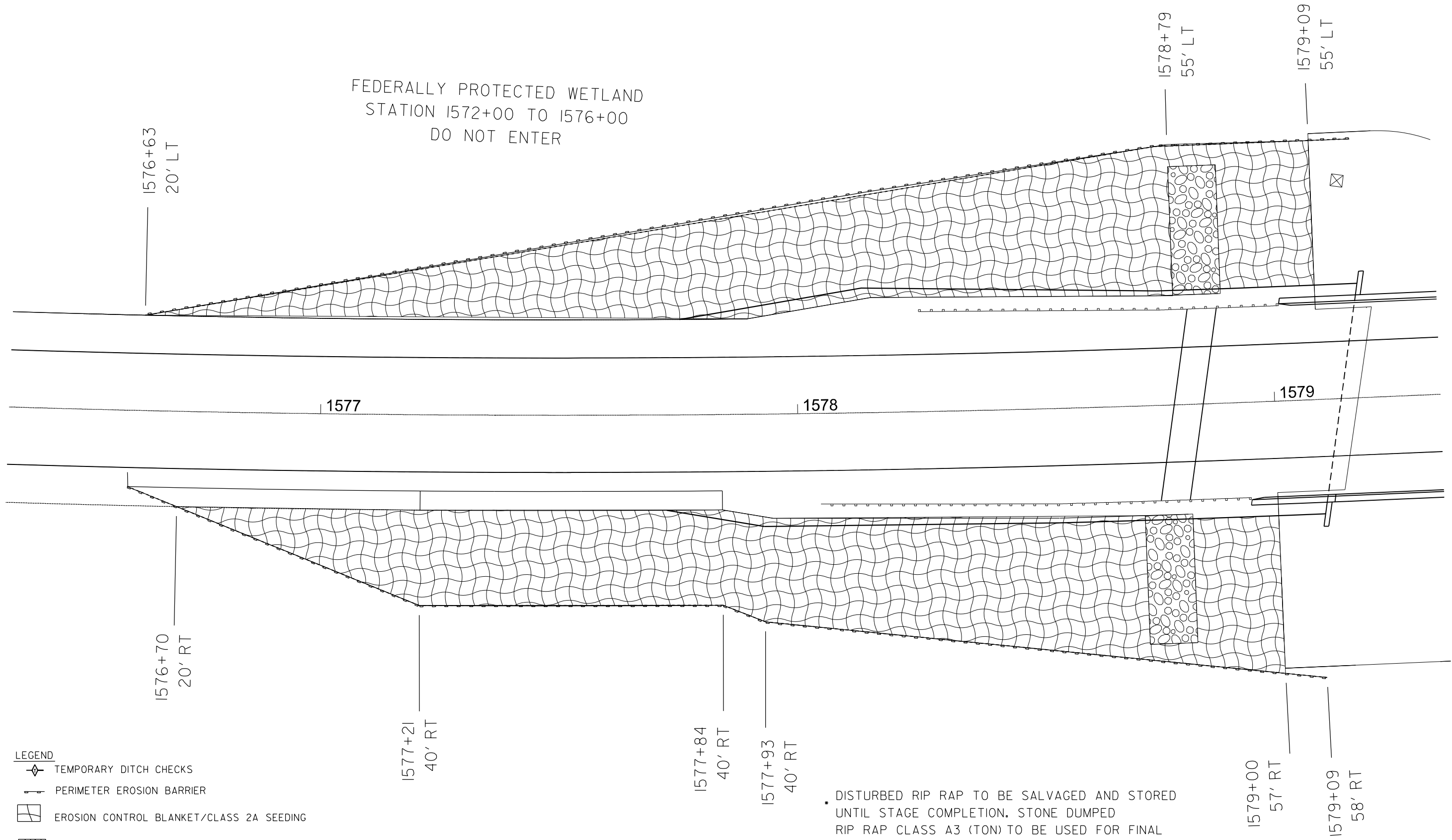

FEDERALLY PROTECTED WETLAND  
STATION 1572+00 TO 1576+00  
DO NOT ENTER



**LEGEND**

-  TEMPORARY DITCH CHECKS
-  PERIMETER EROSION BARRIER
-  EROSION CONTROL BLANKET/CLASS 2A SEEDING
-  \*RIP RAP CLASS A3

DISTURBED RIP RAP TO BE SALVAGED AND STORED  
UNTIL STAGE COMPLETION. STONE DUMPED  
RIP RAP CLASS A3 (TON) TO BE USED FOR FINAL  
FINISH. COST OF SALVAGING RIP RAP SHALL BE INCIDENTAL  
TO THE COST OF RIP RAP CLASS A3

MODEL: IL26 - Erosion Control  
 FILE NAME: P:\GIS\Projects\DOT\Office\District 3\ORD Project\1576M70\CADD\1576M70 Erosion Control

USER NAME = Troy.Hart	DESIGNED -	REVISED -
PLOT SCALE = 0.16666633' / in.	DRAWN -	REVISED -
PLOT DATE = 2/10/2023	CHECKED -	REVISED -
	DATE -	REVISED -

**STATE OF ILLINOIS  
DEPARTMENT OF TRANSPORTATION**

**EROSION CONTROL**

SCALE: 1"=10' SHEETA002 OF SHEETS STA. TO STA.

F.A.P. RTE.	SECTION	COUNTY	TOTAL SHEETS	SHEET NO.
316	(116 BR)BR	BUREAU	49	22
CONTRACT NO. 66M70				
ILLINOIS FED. AID PROJECT				

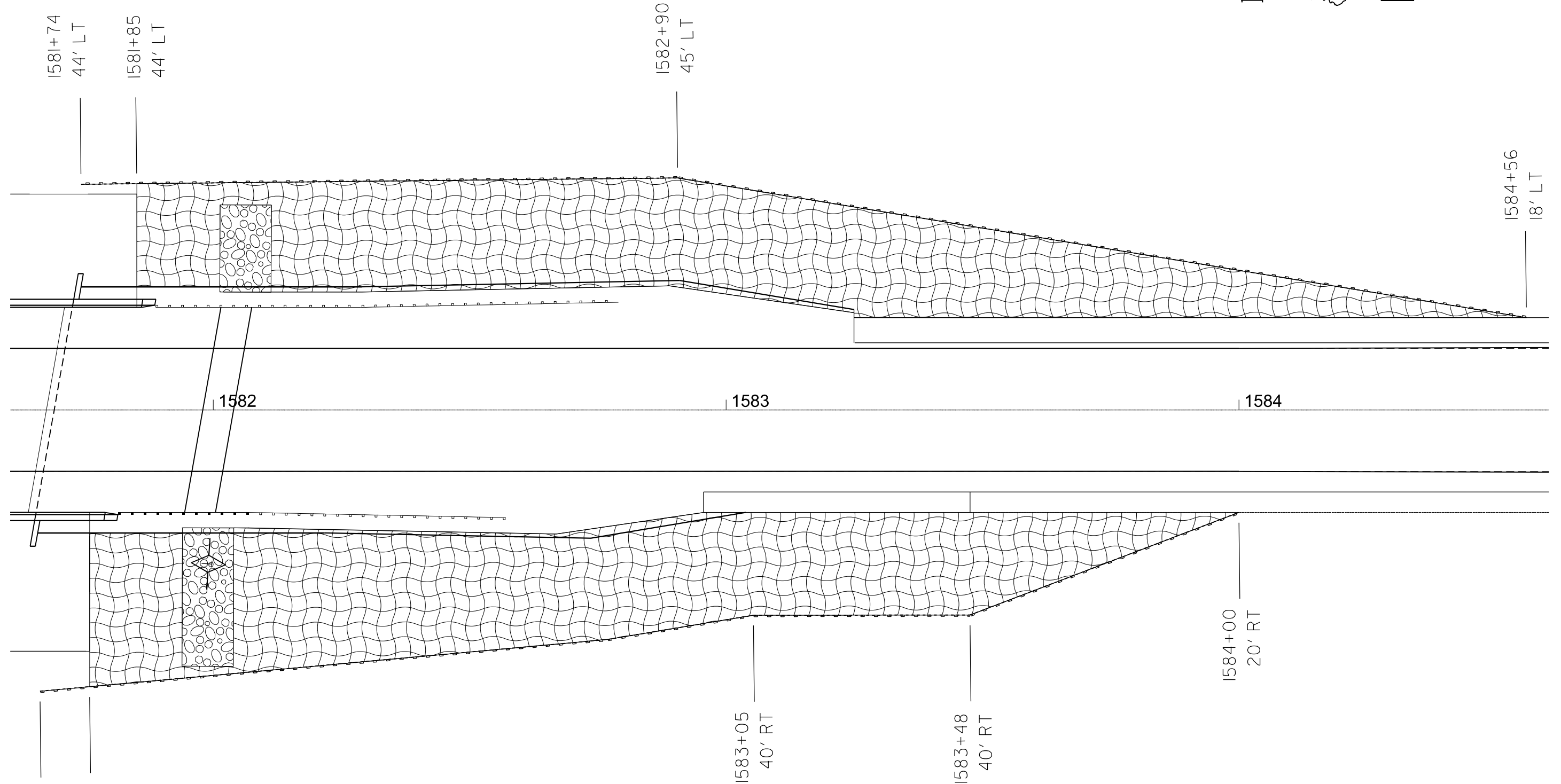

\* DISTURBED RIP RAP TO BE SALVAGED AND STORED UNTIL STAGE COMPLETION. STONE DUMPED RIP RAP CLASS A3 (TON) TO BE USED FOR FINAL FINISH. COST OF SALVAGING RIP RAP SHALL BE INCIDENTAL TO THE COST OF RIP RAP CLASS A3

- LEGEND
- TEMPORARY DITCH CHECKS
  - PERIMETER EROSION BARRIER
  - EROSION CONTROL BLANKET/CLASS 2A SEEDING
  - \*RIP RAP CLASS A3

MODEL: ILL20 - Erosion-2 (Sheet)  
FILE NAME: P:\Bids\Projects\DOT\Office\District 3\ORD Project\0368M70\CADD\DWG\0368M70 Erosion Control

USER NAME = Troy Hart	DESIGNED -	REVISED -
DRAWN -	DRAWN -	REVISED -
PLOT SCALE = 0.08333317' / in.	CHECKED -	REVISED -
PLOT DATE = 2/10/2023	DATE -	REVISED -

**STATE OF ILLINOIS  
DEPARTMENT OF TRANSPORTATION**

**EROSION CONTROL**

SCALE: 1"=10' SHEET 000 OF SHEETS STA. TO STA.

F.A.P. RTE.	SECTION	COUNTY	TOTAL SHEETS	SHEET NO.
116	(116 BR)BR	BUREAU	49	23
CONTRACT NO. 66M70				
ILLINOIS FED. AID PROJECT				

SW 1/4 OF SECTION 28, T. 17 N., R. 9 E., 4TH. P.M.

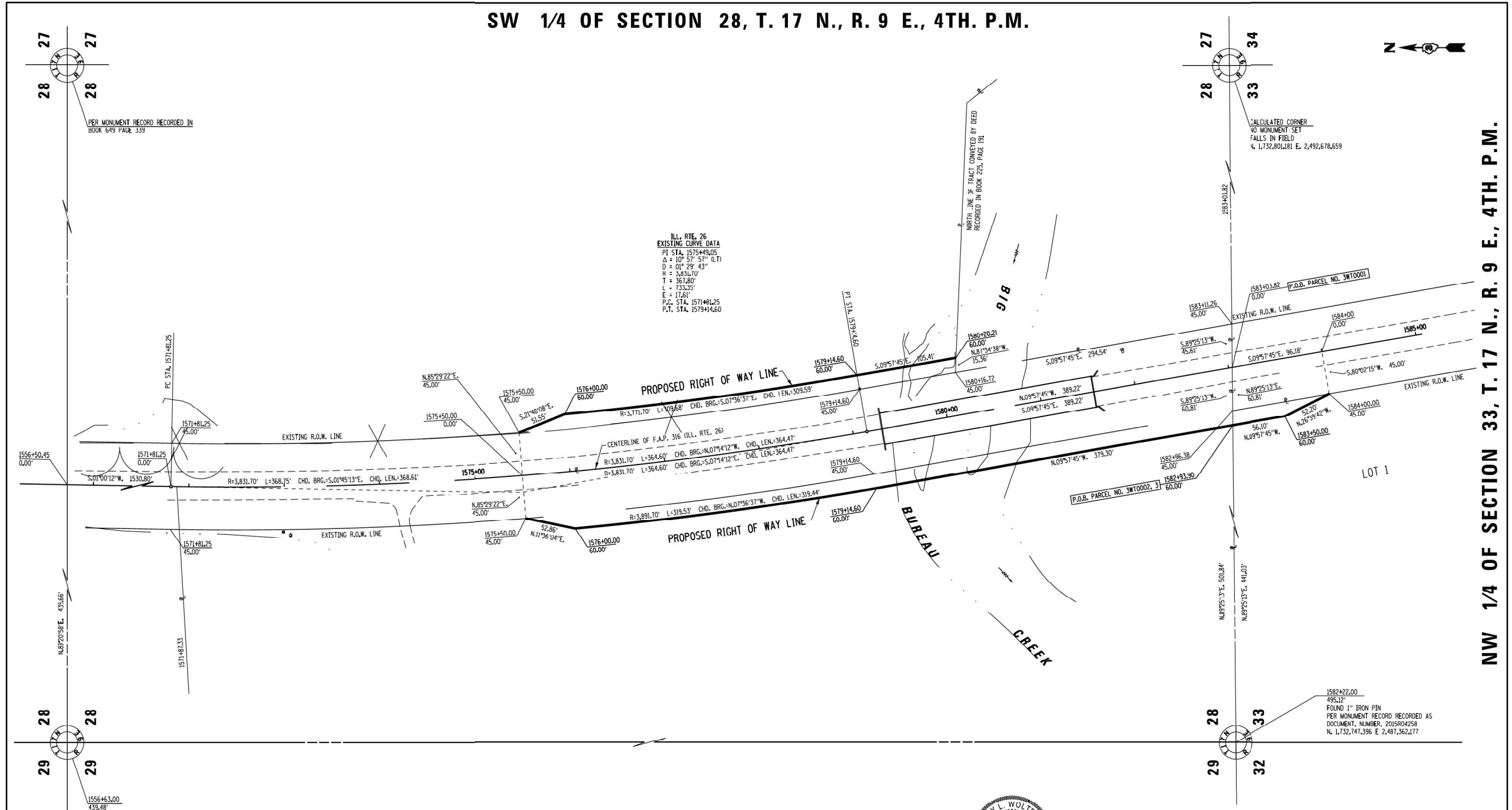

ILL. RTE. 26  
EXISTING CURVE DATA  
PI STA. 1575+49.05  
 $\Delta = 10^\circ 57' 57''$  (LT)  
D =  $01^\circ 29' 43''$   
R = 3,831.70'  
T = 367.80'  
L = 733.35'  
E = 17.61'  
P.C. STA. 1571+81.25  
P.T. STA. 1579+14.60

PROPOSED RIGHT OF WAY LINE

PROPOSED RIGHT OF WAY LINE

**SURVEYOR'S CERTIFICATE**  
I, GERRY L. WOLTERING, CERTIFY THAT I AM A PROFESSIONAL LAND SURVEYOR OF THE STATE OF ILLINOIS, AND THAT TO THE BEST OF MY KNOWLEDGE AND BELIEF, THE PLAT DRAWN HEREON IS A TRUE AND CORRECT REPRESENTATION OF A SURVEY DONE BY ME FOR THE STATE OF ILLINOIS DEPARTMENT OF TRANSPORTATION, AND THAT THE SURVEY IS TRUE AND COMPLETE AS SHOWN, AND THAT ALL MONUMENTS ARE OF THE CHARACTER AND OCCUPY THE POSITION SHOWN THEREON, AND ARE SUFFICIENT TO ENABLE THE SURVEY TO BE RETRACED. THIS PROFESSIONAL SERVICE CONFORMS TO THE CURRENT ILLINOIS MINIMUM STANDARDS FOR A BOUNDARY SURVEY.



NOTE: GRID BEARINGS AND DISTANCES SHOWN HEREON ARE REFERENCED TO THE ILLINOIS STATE PLANE COORDINATE SYSTEM, WEST ZONE, (NAD 83, 2007 ADJ.) ALL AREAS ARE BASED ON GROUND DISTANCES.  
GRID TO GROUND COMBINED FACTOR = 1.0000464  
TOTAL HOLDINGS TAKEN FROM TAX ASSESSOR OFFICE



FILE NAME	USER NAME = woodger.jp	DESIGNED -	REVISED PARCEL 2 NAME 11-16-15
		CHECKED -	REVISED -
	PLOT SCALE = 100.0000' / in.	DATE -	REVISED -
	PLOT DATE = 8/3/2017		

STATE OF ILLINOIS  
DEPARTMENT OF TRANSPORTATION

RIGHT OF WAY PLANS  
PROJECT: JOB NO. R-93-005-11  
SHEET NO. 1 OF 1 STA. 1575+00 TO STA. 1584+00

FAP	SECTION	COUNTY	TOTAL SHEETS	SHEET NO.
316	(116 BR)R	BUREAU	91	33
ILLINOIS ROUTE 26		CONTRACT NO. 66A19		
FED. ROAD DIST. NO.		ILLINOIS FED. AID PROJECT		

**FOR INFORMATION ONLY**

FILE NAME =	USER NAME = Troy.Hart	DESIGNED -	REVISED -
		CHECKED -	REVISED -
	PLOT SCALE = 100.0000' / in.	DATE -	REVISED -
	PLOT DATE = 2/9/2023		

STATE OF ILLINOIS  
DEPARTMENT OF TRANSPORTATION

EXISTING R.O.W.  
SCALE: SHEET NO. - OF - SHEETS STA. TO STA.

F.A.P. RTE.	SECTION	COUNTY	TOTAL SHEETS	SHEET NO.
316	(116 BR)I	BUREAU	49	24
ILLINOIS ROUTE 26		CONTRACT NO. 66M70		
FED. ROAD DIST. NO.		ILLINOIS FED. AID PROJECT		



Benchmarks: #5, chisled "□" top northeast wingwall of S.N. 006-0187, Elev. 638.55

Existing Structure: S.N. 006-0187 was originally built in 2018 as a three-span welded plate girder structure with integral abutments and pile bent piers. The back to back abutment length = 255'-0" and the out to out width = 43'-2". Structure is to be repaired as detailed in these plans. One lane on traffic will be maintained utilizing stage construction.

No Salvage.

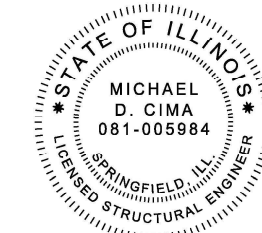
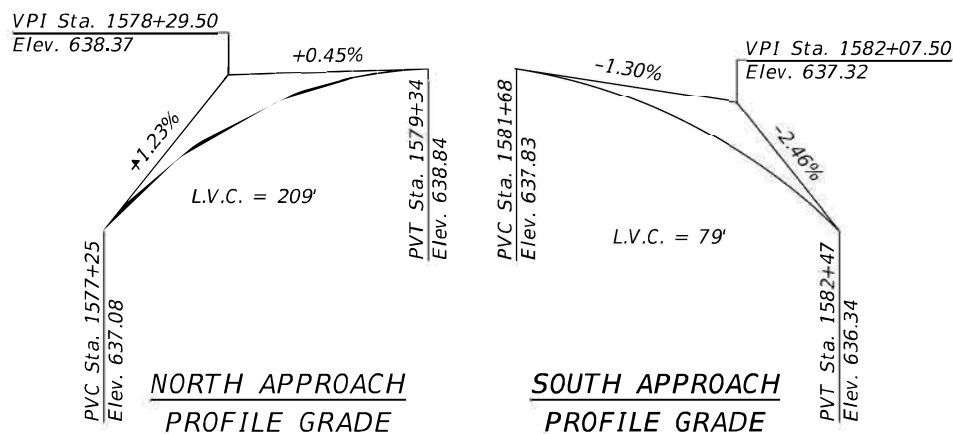

*Michael D. Cima* 1/9/2023  
 Michael D. Cima, Illinois S.E. 081-005984 Date  
 Expires 11/30/2024

**CURVE DATA**

EXIST. CURVE 0136CL - 1  
 P.I. Sta. = 1575+49.05  
 $\Delta = 10^\circ 57' 57''$  (LT)  
 $D = 1^\circ 29' 43''$   
 $R = 3,831.70'$   
 $T = 367.80'$   
 $L = 733.35'$   
 $E = 17.61'$   
 $e = 3.20\%$   
 $T.R. = 38'$   
 $S.E. Run = 82'$   
 FULL SUPER from STA. 1575+50.00 to STA. 1578+87.54  
 S.E. TRANS. from STA. 1578+87.54 to STA. 1580+07.54  
 P.C. Sta. = 1571+81.25  
 P.T. Sta. = 1579+14.60

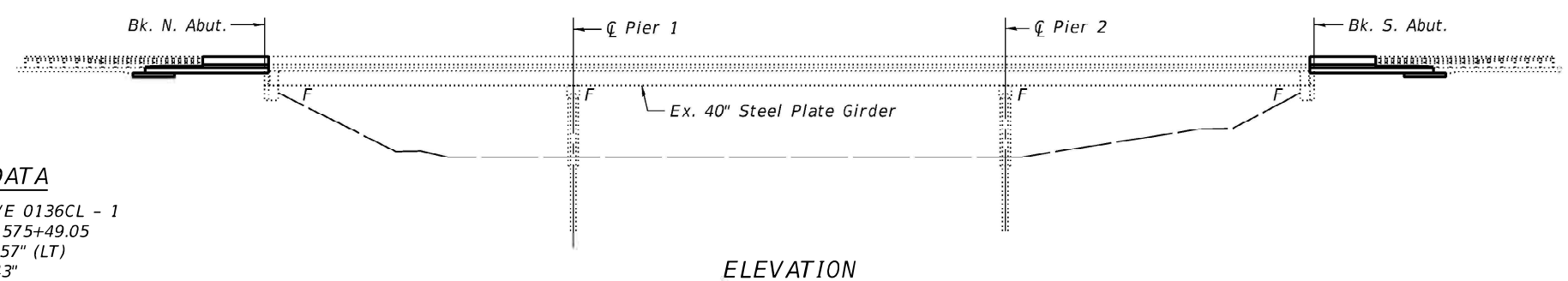

**ELEVATION**

**GENERAL NOTES**

- Reinforcement bars designated (E) shall be epoxy coated.
- Plan dimensions and details relative to existing plans are subject to nominal construction variations. The Contractor shall field verify existing dimensions and details affecting new construction and make necessary approved adjustments prior to construction or ordering of materials. Such variations shall not be cause for additional compensation for a change in scope of the work, however, the Contractor will be paid for the quantity actually furnished at the unit price bid for the work.
- Joint openings shall be adjusted according to Art. 520.04 of the Standard Specifications when the approach slab is poured at an ambient temperature other than 50°F.
- Protective coat shall be applied to the top and front face of the new approach parapets and new approach slabs.
- Existing guardrail at each end shall be removed, stored and reinstalled during each stage of construction.

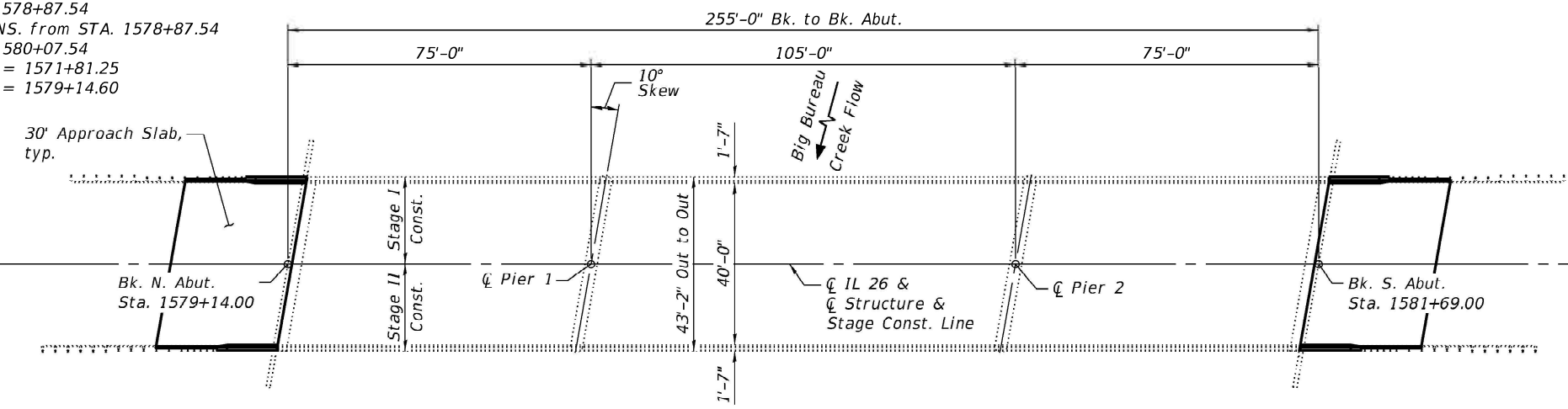

**PLAN**

**TOTAL BILL OF MATERIAL**

Item	Unit	Super	Sub	Total
Concrete Removal	Cu. Yd.	7.1	26.3	33.4
Concrete Structures	Cu. Yd.	-	26.3	26.3
Concrete Superstructure	Cu. Yd.	6.7	-	6.7
Bridge Deck Grooving	Sq. Yd.	254	-	254
Protective Coat	Sq. Yd.	300	-	300
Concrete Superstructure (Approach Slab)	Cu. Yd.	118.1	-	118.1
Reinforcement Bars, Epoxy Coated	Pound	44,170	4,640	48,810
Bar Splicers	Each	212	80	292
Approach Slab Removal	Sq. Yd.	284	-	284

**INDEX OF SHEETS**

- General Plan and Elevation
- Stage Construction Details
- Temporary Concrete Barrier
5. Top of Approach Slab Elevations
- Approach Removal
- 7-8. Bridge Approach Slab Details
- Bar Splicer Assembly and Mechanical Splicer Details

**DESIGN SPECIFICATIONS**

2020 AASHTO LRFD Bridge Design Specifications, 9th Edition

**LOADING HL-93**

Allow 50#/sq. ft. for future wearing surface.

**DESIGN STRESSES**

**FIELD UNITS (EXIST. CONST.)**  
 $f'_c = 3,500$  psi  
 $f_y = 60,000$  psi (Reinforcement)  
 $f_y = 50,000$  psi (AASHTO M270 Grade 50W)

**FIELD UNITS (NEW CONST.)**  
 $f'_c = 4,000$  psi (Superstructure)  
 $f'_c = 3,500$  psi (Substructure)  
 $f_y = 60,000$  psi (Reinforcement)  
 $f_y = 36,000$  psi (AASHTO M270 Grade 36)

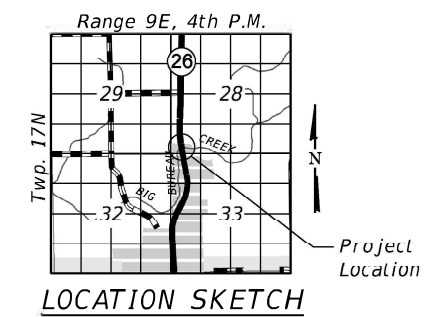

**LOCATION SKETCH**

**GENERAL PLAN AND ELEVATION**  
**IL ROUTE 26 OVER BIG BUREAU CREEK**  
**F.A.P. 316 - SECTION (116 BR)BR**  
**BUREAU COUNTY**  
**STA. 1580+41.50**  
**STRUCTURE NO. 006-0187**

MODEL: Default  
 FILE NAME: I:\Projects\2020\101005 - FTB 194-29 D3 - ESCA - Various Phase I\I\W0#8 IL-26 BR Repairs\CADD\Sheets\0060187-66M70-001-GPE.dgn  
 1/9/2023 4:26:21 PM

<p>QUIGG ENGINEERING INC</p>	USER NAME = cstokes 0060187-66M70-001-GPE.dgn PLOT SCALE = 40:0.0000" = 1" / in. PLOT DATE = 1/9/2023	DESIGNED - CFS CHECKED - KFO DRAWN - CFS CHECKED - MDC	REVISED - REVISED - REVISED - REVISED -	STATE OF ILLINOIS DEPARTMENT OF TRANSPORTATION	GENERAL PLAN AND ELEVATION STRUCTURE NO. 006-0187 SHEET 1 OF 9 SHEETS	F.A.P. RTE. 316 SECTION (116 BR)I COUNTY BUREAU TOTAL SHEETS 49 SHEET NO. 25 CONTRACT NO. 66M70 ILLINOIS FED. AID PROJECT
------------------------------	--	---	--	---	---	---

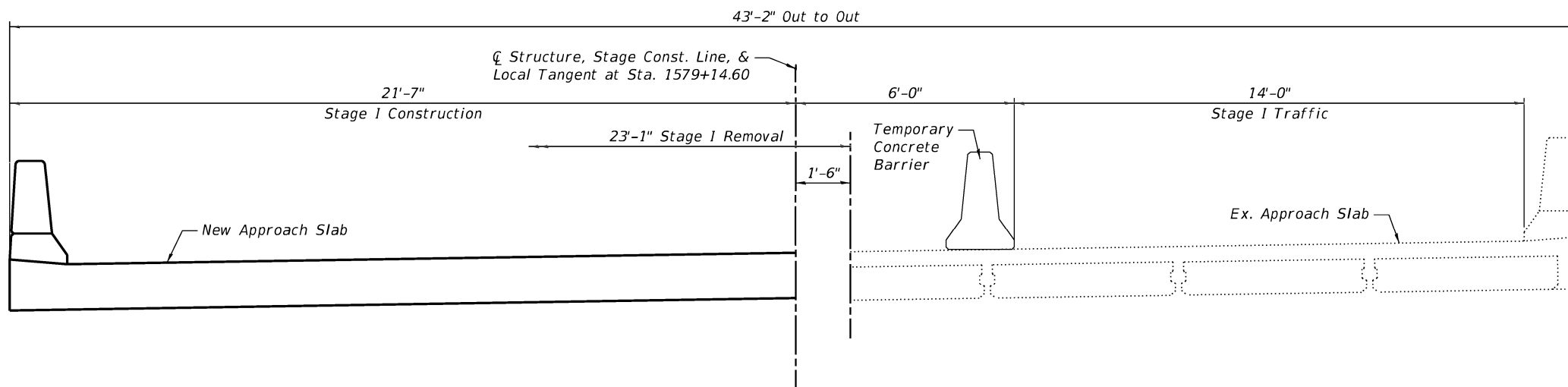

**STAGE I REMOVAL AND CONSTRUCTION**

(Looking South near Abutment)  
 (North approach slab shown; South approach slab similar)

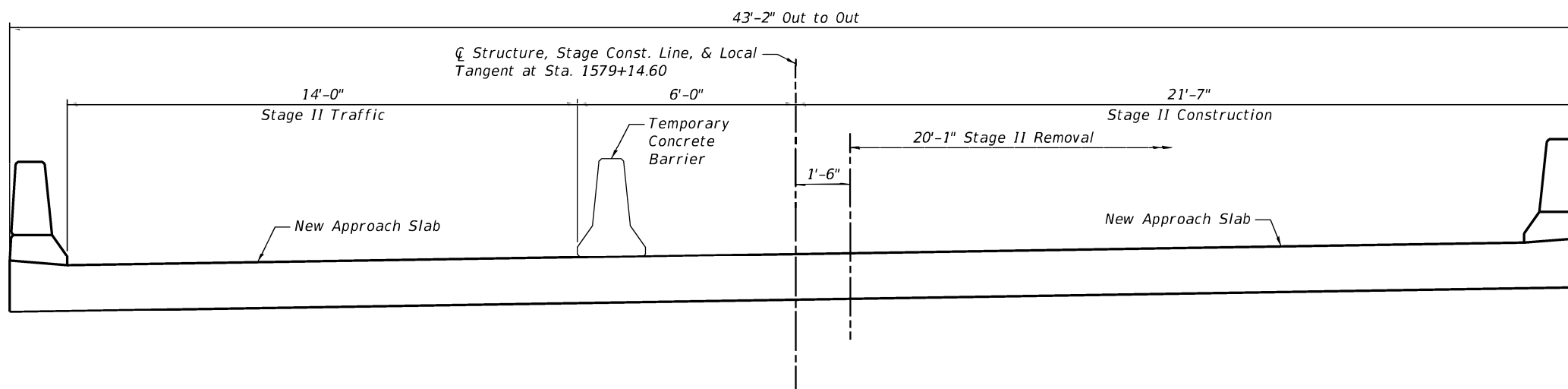

**STAGE II REMOVAL AND CONSTRUCTION**

(Looking South near Abutment)  
 (North approach slab shown; South approach slab similar)

MODEL: Default  
 FILE NAME: I:\B01\Projects\2020\2011005 - PTB 194-29 D3 - ESCA - Various Phase I\I\WO#8 IL-26 BR Repairs\CADD\Sheets\0060187-66M70-002-StageConstr.dgn



QUIGG ENGINEERING INC

USER NAME =	cstokes	DESIGNED -	CFS	REVISED -	
FILE NAME =	0060187-66M70-002-StageConstr.dgn	CHECKED -	KFO	REVISED -	
PLOT SCALE =	0:2.0000 "/in.	DRAWN -	CFS	REVISED -	
PLOT DATE =	1/9/2023	CHECKED -	MDC	REVISED -	

STATE OF ILLINOIS  
 DEPARTMENT OF TRANSPORTATION

STAGE CONSTRUCTION DETAILS  
 STRUCTURE NO. 006-0187

SHEET 2 OF 9 SHEETS

F.A.P. RTE.	SECTION	COUNTY	TOTAL SHEETS	SHEET NO.
316	(116 BR)	BUREAU	47	26
CONTRACT NO. 66M70				
ILLINOIS FED. AID PROJECT				

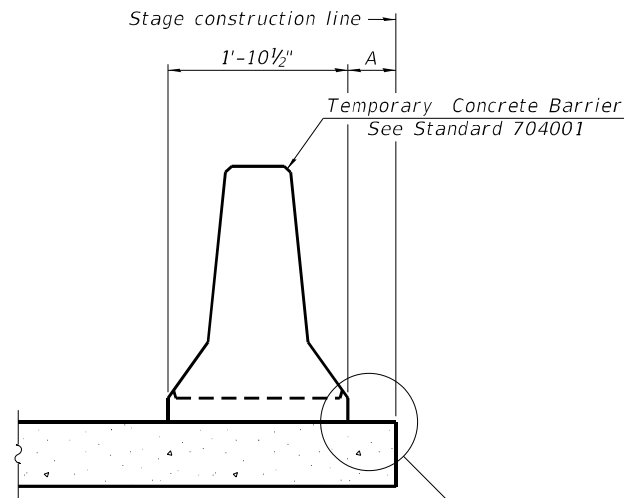

When "A" is 3'-1" or less, the temporary concrete barrier shall be restrained to the new slab according to Detail I, II or III. No restraint is required when "A" is greater than 3'-1".

NEW SLAB OR NEW DECK BEAM

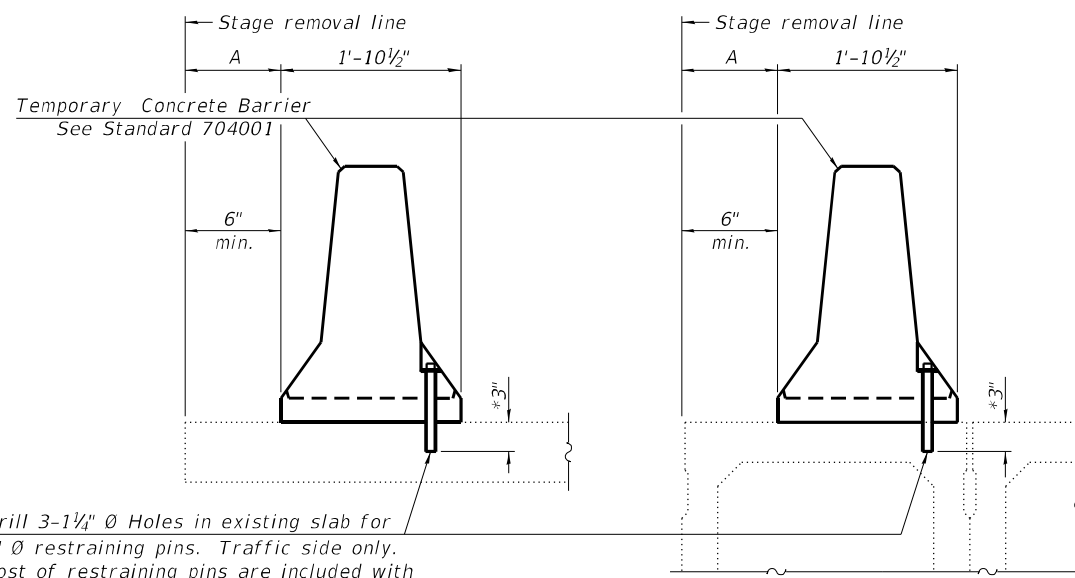

Drill 3-1/4" Ø Holes in existing slab for 1" Ø restraining pins. Traffic side only. Cost of restraining pins are included with Temporary Concrete Barrier. No restraint is required when "A" is greater than 3'-1".

EXISTING SLAB

\* When hot-mix asphalt wearing surface is present, embedment shall be 3" plus the wearing surface depth.

EXISTING DECK BEAM

SECTIONS THRU SLAB OR DECK BEAM

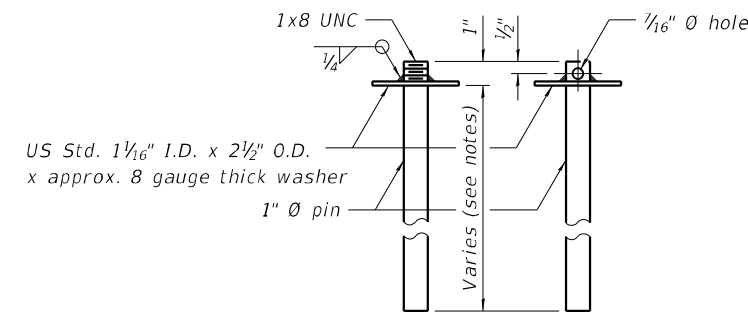

RESTRAINING PIN

US Std. 1 1/16" I.D. x 2 1/2" O.D. x approx. 8 gauge thick washer

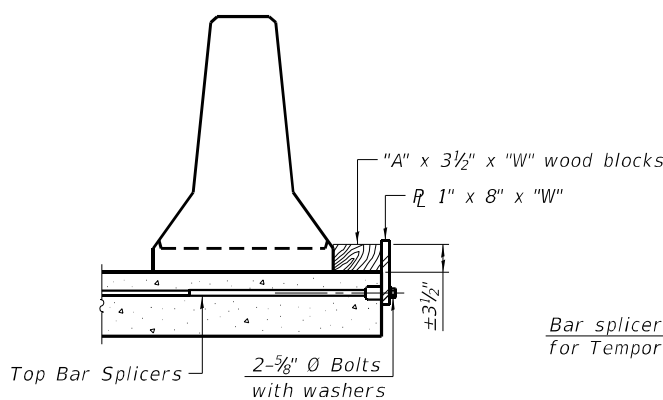

DETAIL I

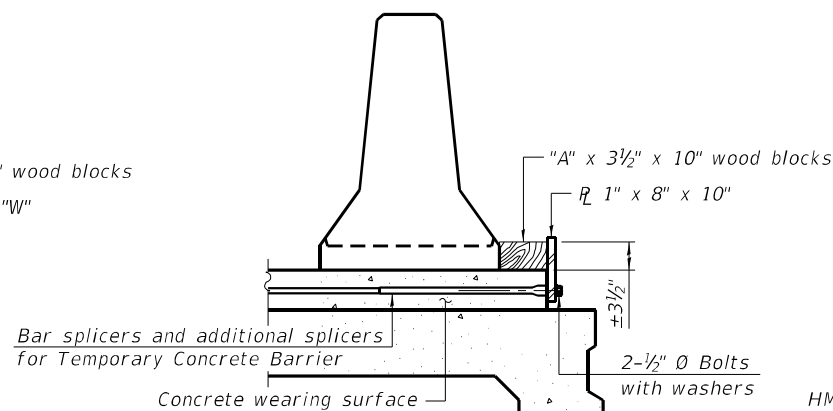

DETAIL II

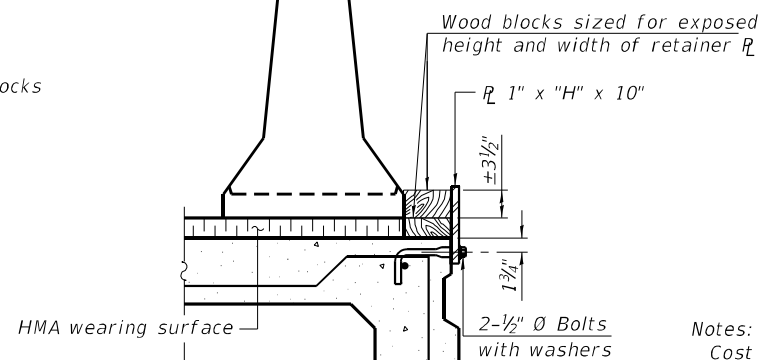

DETAIL III

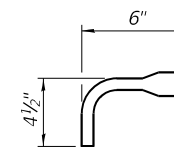

BAR SPLICER FOR #4 BAR - DETAIL III

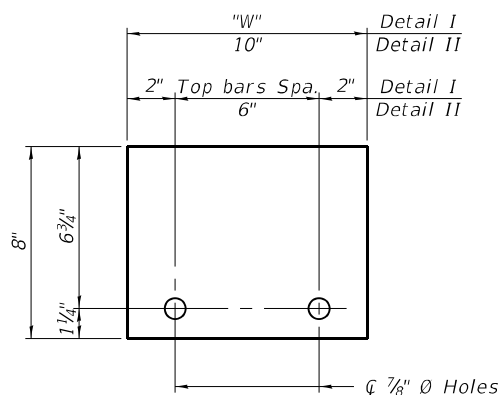

STEEL RETAINER R 1" x 8" x "W" (Detail I and II)

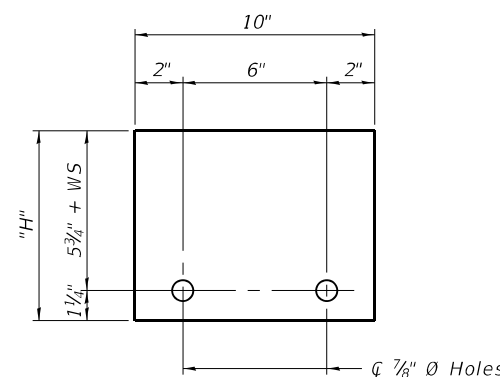

STEEL RETAINER R 1" x "H" x 10" (Detail III)

Notes:  
 Cost of retainer assembly is included with Temporary Concrete Barrier.  
 A retainer assembly shall be located at the approximate  $\frac{1}{2}$  of each temporary concrete barrier.  
 The retainer plate shall not be removed until the concrete on the adjacent stage is ready to be poured. For Detail III applications the retainer plate shall not be removed until just prior to placing the adjacent beam.  
 When the 'A' dimension is less than 1 1/2', the wood block shall be omitted and the barrier shall be placed in direct contact with the steel retainer plate. For deck beam applications the minimum required 'A' distance is 6" to accommodate the shear key clamping device.

Detail I - Installation for a new bridge deck or bridge slab.  
 Detail II - Installation for a new deck beam with an initial concrete wearing surface. Additional bar splicers shall be provided at 6'-0" centers and paired with the bar splicers of the concrete wearing surface reinforcement to accommodate the installation of the retainer assemblies. The cost of the additional bar splicers is included with the concrete wearing surface.  
 Detail III - Installation for a new deck beam with no initial wearing surface or with an initial hot-mix asphalt (HMA) wearing surface present. The deck beam directly beneath the temporary concrete barrier shall be fabricated with bar splicer inserts in the side of the beam, as detailed, to accommodate the installation of the retainer assemblies. A pair of bar splicers, 6" apart, shall be placed at 6'-0" centers along the length of the beam. The cost of the bar splicers is included with the deck beam.

RAILING CRITERIA

NCHRP 350 Test Level	3
Railing Weight (plf)	440

R-27 10-12-2021

MODEL: Default  
 FILE NAME: \\bs01\Projects\2020\2011005 - PTB 194+29 D3 - ESCA - Various Phase I\IWO#8 IL-26 BR Repairs\CADD\CADD\_Sheets\0060187-66M70-003-TempBarrier.dgn



USER NAME =	cslokes	DESIGNED -	CFS	REVISED -	
	0060187-66M70-003-TempBarrier.dgn	CHECKED -	KFO	REVISED -	
PLOT SCALE =	0:2.0000 "/>				
PLOT DATE =	1/9/2023	CHECKED -	MDC	REVISED -	

STATE OF ILLINOIS  
 DEPARTMENT OF TRANSPORTATION

TEMPORARY CONCRETE BARRIER  
 STRUCTURE NO. 006-0187

SHEET 3 OF 9 SHEETS

F.A.P. RTE.	SECTION	COUNTY	TOTAL SHEETS	SHEET NO.
316	(116 BR)	BUREAU	49	27
CONTRACT NO. 66M70				
ILLINOIS FED. AID PROJECT				

EAST CURB LINE / EAST FACE OF PARAPET

Location	Station	Offset	Theoretical Grade Elevations
N. End of N. Appr.	1578+88.48	-20.33	637.95
A	1578+98.53	-20.38	638.09
B	1579+08.51	-20.00	638.24
S. End of N. Appr.	1579+18.54	-20.00	638.37

EAST EDGE OF PAVEMENT

Location	Station	Offset	Theoretical Grade Elevations
N. End of N. Appr.	1578+87.06	-12.00	638.20
A	1578+97.08	-12.00	638.31
B	1579+07.11	-12.00	638.41
S. End of N. Appr.	1579+17.13	-12.00	638.51

CL IL-26 AND PROFILE GRADE LINE

Location	Station	Offset	Theoretical Grade Elevations
N. End of N. Appr.	1578+85.04	0.00	638.57
A	1578+95.03	0.00	638.63
B	1579+05.02	0.00	638.69
S. End of N. Appr.	1579+15.02	0.00	638.74

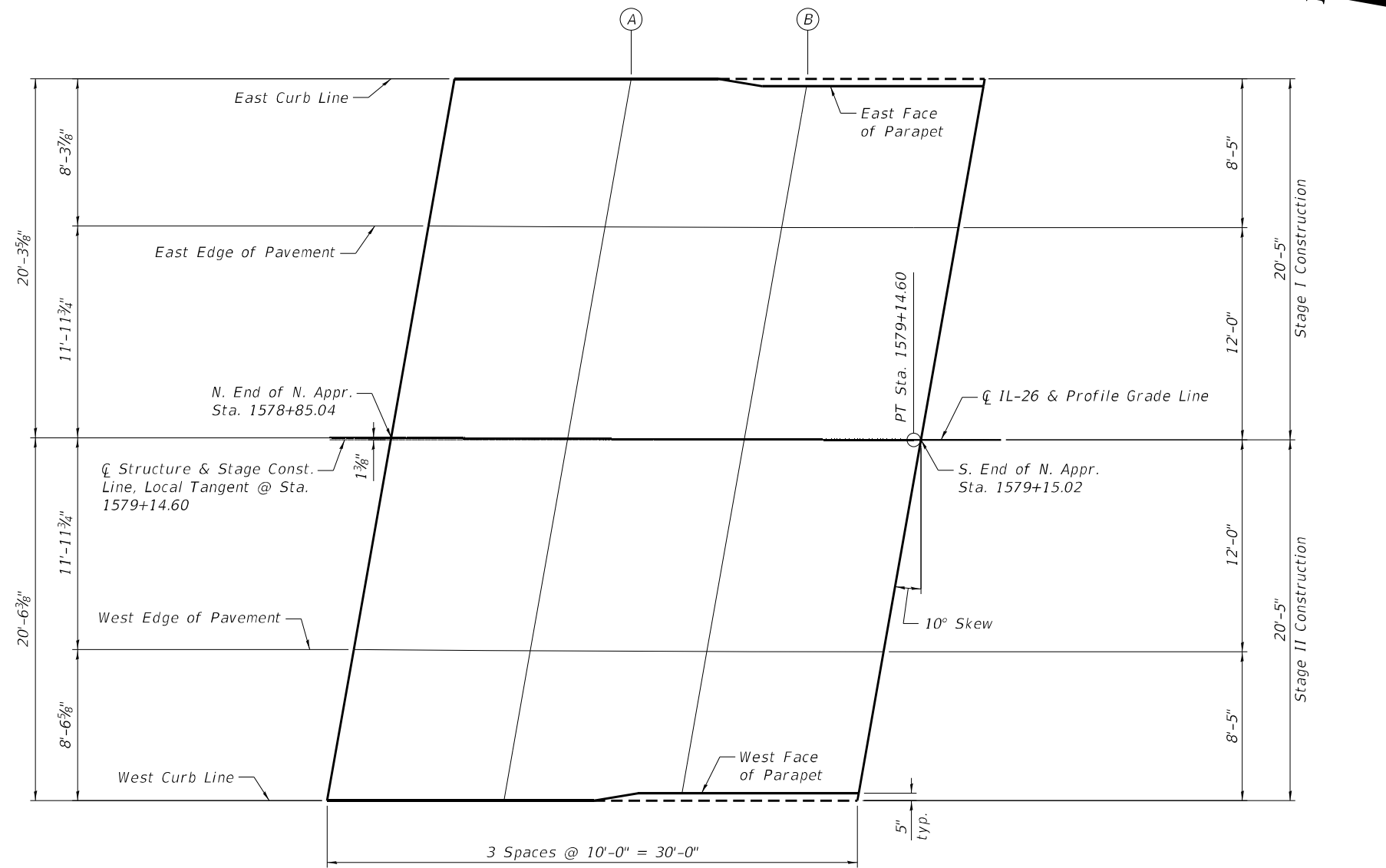

NORTH APPROACH SLAB PLAN

WEST EDGE OF PAVEMENT

Location	Station	Offset	Theoretical Grade Elevations
N. End of N. Appr.	1578+83.02	12.00	638.94
A	1578+92.98	12.00	638.98
B	1579+02.94	12.00	638.99
S. End of N. Appr.	1579+12.90	12.00	639.00

WEST CURB LINE / WEST FACE OF PARAPET

Location	Station	Offset	Theoretical Grade Elevations
N. End of N. Appr.	1578+81.59	20.56	639.21
A	1578+91.54	20.49	639.23
B	1579+01.56	20.02	639.20
S. End of N. Appr.	1579+11.51	20.00	639.17

Notes:  
 Offsets are measured perpendicular from CL of IL-26.  
 Transverse dimensions are measured perpendicular to CL structure.  
 Longitudinal dimensions are measured parallel to CL structure.

MODEL: Default  
 FILE NAME: \\b501\Projects\2020\11\005 - PTB 194+29 D3 - ESCA - Various Phase 1\IWO#8 IL-26 BR Repairs\CADD\CADD\_Sheets\0060187-66M70-004-NApprElev.dgn  
 1/9/2023 4:26:25 PM

E-AS 2-17-2017



USER NAME = cstkos	DESIGNED - CFS	REVISED -
0060187-66M70-004-NApprElev.dgn	CHECKED - KFO	REVISED -
PLOT SCALE = 0:2.0000 "/>		
PLOT DATE = 1/9/2023	CHECKED - MDC	REVISED -

STATE OF ILLINOIS  
 DEPARTMENT OF TRANSPORTATION

TOP OF APPROACH SLAB ELEVATIONS  
 STRUCTURE NO. 006-0187

SHEET 4 OF 9 SHEETS

F.A.P. RTE. 316	SECTION (116 BR)	COUNTY BUREAU	TOTAL SHEETS 49	SHEET NO. 28
CONTRACT NO. 66M70				
ILLINOIS FED. AID PROJECT				

EAST CURB LINE / EAST FACE OF PARAPET

Location	Station	Offset	Theoretical Grade Elevations
N. End of S. Appr.	1581+71.51	-20.00	637.47
A	1581+81.51	-20.00	637.33
B	1581+91.58	-20.42	637.16
S. End of S. Appr.	1582+01.58	-20.42	636.99

EAST EDGE OF PAVEMENT

Location	Station	Offset	Theoretical Grade Elevations
N. End of S. Appr.	1581+70.10	-12.00	637.62
A	1581+80.10	-12.00	637.47
B	1581+90.10	-12.00	637.32
S. End of S. Appr.	1582+00.10	-12.00	637.15

CL IL-26 AND PROFILE GRADE LINE

Location	Station	Offset	Theoretical Grade Elevations
N. End of S. Appr.	1581+67.98	0.00	637.83
A	1581+77.98	0.00	637.69
B	1581+87.98	0.00	637.54
S. End of S. Appr.	1581+97.98	0.00	637.37

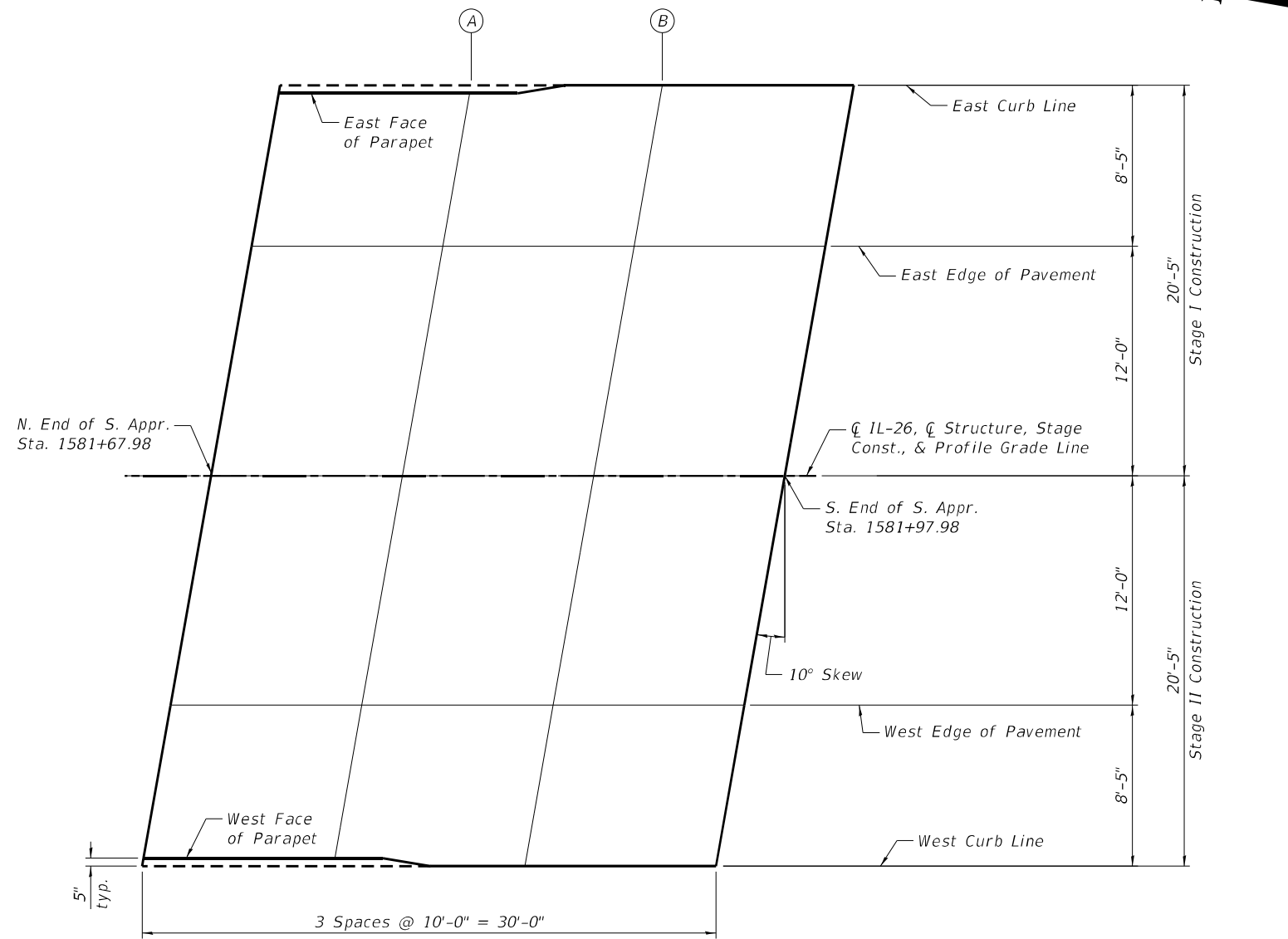

SOUTH APPROACH SLAB PLAN

WEST EDGE OF PAVEMENT

Location	Station	Offset	Theoretical Grade Elevations
N. End of S. Appr.	1581+65.86	12.00	637.67
A	1581+75.86	12.00	637.54
B	1581+85.86	12.00	637.39
S. End of S. Appr.	1581+95.86	12.00	637.22

WEST CURB LINE / WEST FACE OF PARAPET

Location	Station	Offset	Theoretical Grade Elevations
N. End of S. Appr.	1581+64.45	20.00	637.56
A	1581+74.45	20.00	637.43
B	1581+84.38	20.42	637.28
S. End of S. Appr.	1581+94.38	20.42	637.12

MODEL: Default  
FILE NAME: \\bs01\Projects\2020\2011005 - PTB 194+29 D3 - ESCA - Various Phase I\IWO#8 IL-26 BR Repairs\CADD\CADD\_Sheets\0060187-66M70-005-SApprElev.dgn

E-AS 2-17-2017



QUIGG ENGINEERING INC

USER NAME =	cslokes	DESIGNED -	CFS	REVISED -	
	0060187-66M70-005-SApprElev.dgn	CHECKED -	KFO	REVISED -	
PLOT SCALE =	0:2.0000 "/>				
PLOT DATE =	1/9/2023	CHECKED -	MDC	REVISED -	

STATE OF ILLINOIS  
DEPARTMENT OF TRANSPORTATION

TOP OF APPROACH SLAB ELEVATIONS  
STRUCTURE NO. 006-0187

SHEET 5 OF 9 SHEETS

F.A.P. RTE.	SECTION	COUNTY	TOTAL SHEETS	SHEET NO.
316	(116 BR)I	BUREAU	49	29
CONTRACT NO. 66M70				
ILLINOIS FED. AID PROJECT				

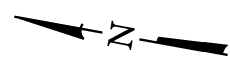

Remove and store existing guardrail as needed for approach slab removal and reconstruction, Guardrail to be reinstalled with new construction. Typ.

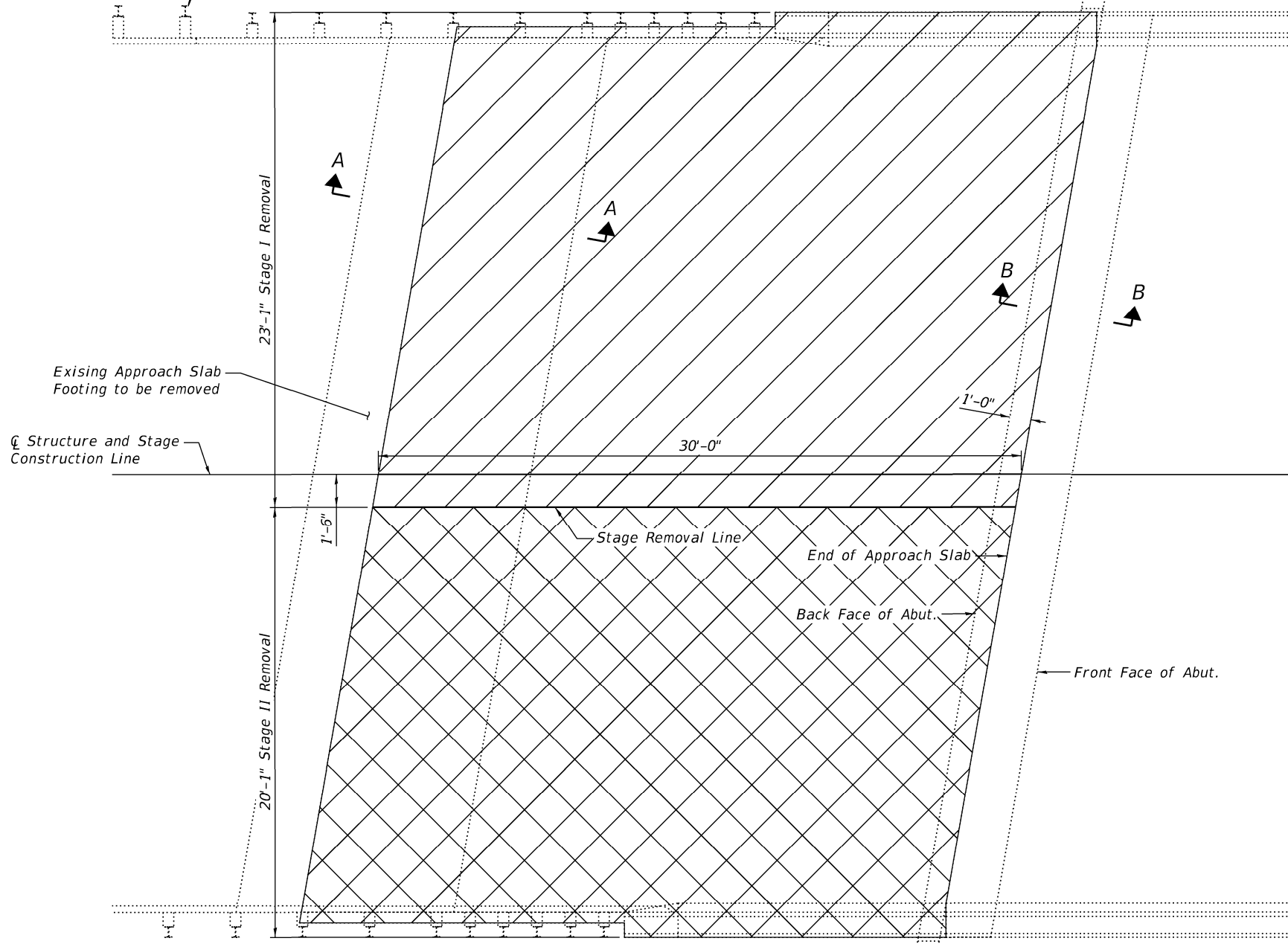

**EXISTING APPROACH SLAB PLAN**  
(North approach slab shown; South approach slab similar)

- LEGEND**
- Existing Structure Removal Stage I
  - Existing Structure Removal Stage II

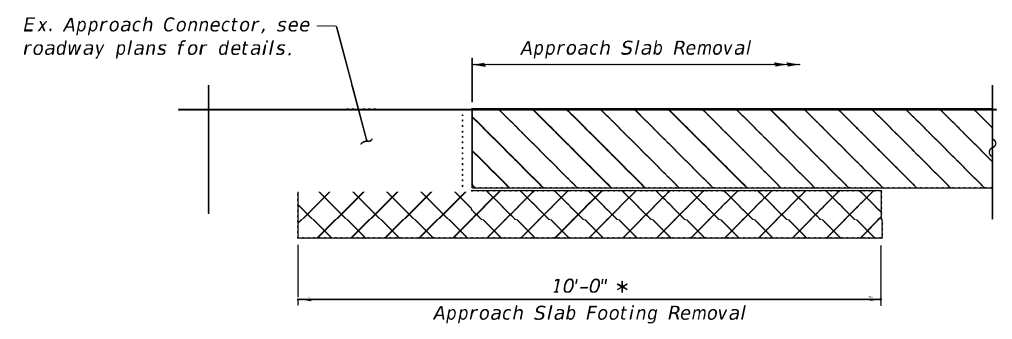

**SECTION A-A**

\* Measured perpendicular to centerline of joint.

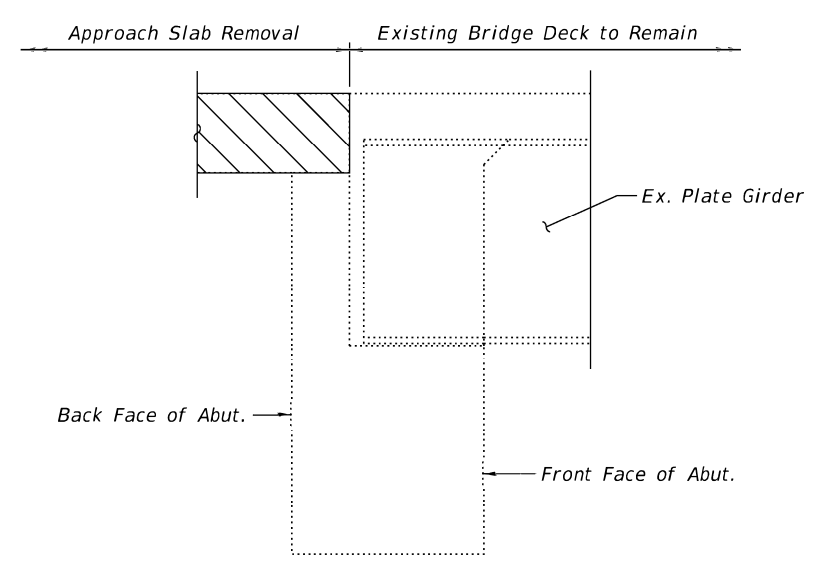

**SECTION B-B**

**LEGEND**

- Concrete Removal
- Approach Pavement Removal

**Notes:**  
 Cut off existing Approach Pavement dowel bars flush with the existing abutment bearing seat.  
 Pavement removal above the Approach Slab Footing is detailed and paid for in the roadway plans.  
 Removal of existing approach slab includes the 5" concrete wearing surface and precast panels. Cost included in Approach Slab Removal.

**BILL OF MATERIAL**

Item	Unit	Total
Concrete Removal	Cu. Yd.	33.4
Approach Slab Removal	Sq. Yd.	284

MODEL: Default  
 FILE NAME: pw://idiot-pw.bentley.com/pw/IDOT/Documents/IDOT\_0\_ces/District\_3/ORD Projects/D366M70/CADDData/CADSheets/0060187-66M70-006-Removal.dgn  
 2/8/2023 2:28:44 PM



USER NAME = Troy Hart	DESIGNED - CFS	REVISED -
0060187-66M70-006-Removal.dgn	CHECKED - KFO	REVISED -
PLOT SCALE = 0.2,0000 "/>		

**STATE OF ILLINOIS**  
**DEPARTMENT OF TRANSPORTATION**

**APPROACH REMOVAL**  
**STRUCTURE NO. 006-0187**

SHEET 6 OF 9 SHEETS

F.A.P. RTE.	SECTION	COUNTY	TOTAL SHEETS	SHEET NO.
316	(116 BR)	BUREAU	49	30
			CONTRACT NO. 66M70	
ILLINOIS FED. AID PROJECT				

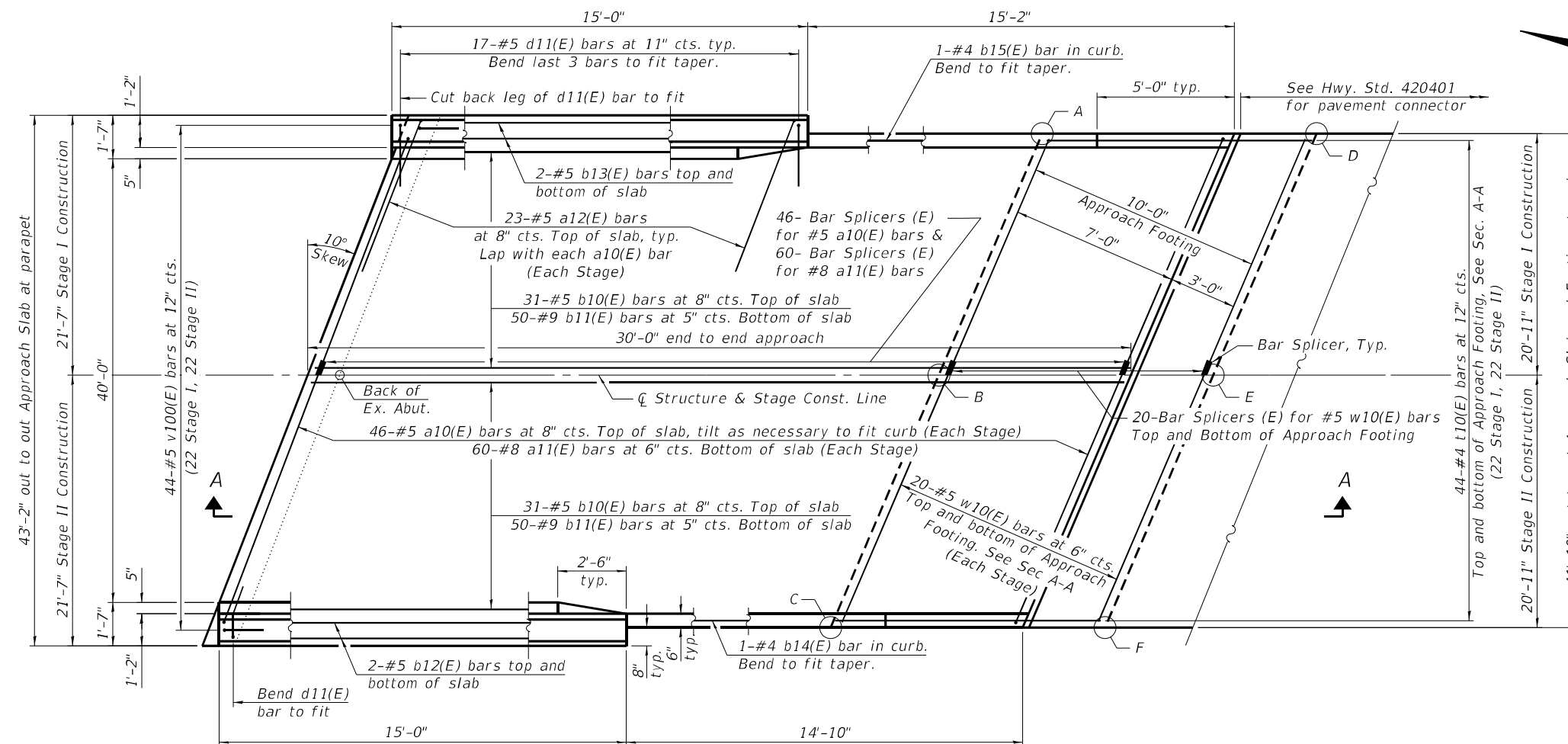

**TOP AND BOTTOM ELEVATIONS  
FOR APPROACH FOOTING**

Point/ Location	North Approach		South Approach	
	Top	Bottom	Top	Bottom
A-SW	638.01	637.17	A-NE	635.86
B-S SCL	637.37	636.53	B-N SCL	636.24
C-SE	636.79	635.95	C-NW	635.98
D-NW	637.95	637.12	D-SE	635.68
E-N SCL	637.31	636.47	E-S SCL	636.07
F-NE	636.66	635.82	F-SW	635.81

Where "SCL" is Stage Construction Line

**Notes:**  
 Cross section transitions from super elevation at Sta. 1578+87.54 to normal crown at Sta. 1580+07.54.  
 Transverse dimensions are measured perpendicular to  $\phi$  structure, U.N.O.  
 Longitudinal dimensions are measured parallel to  $\phi$  structure.

\* Dimensions measured perpendicular to  $\phi$  IL-26

**PLAN**  
 (South approach slab shown; North approach slab similar)

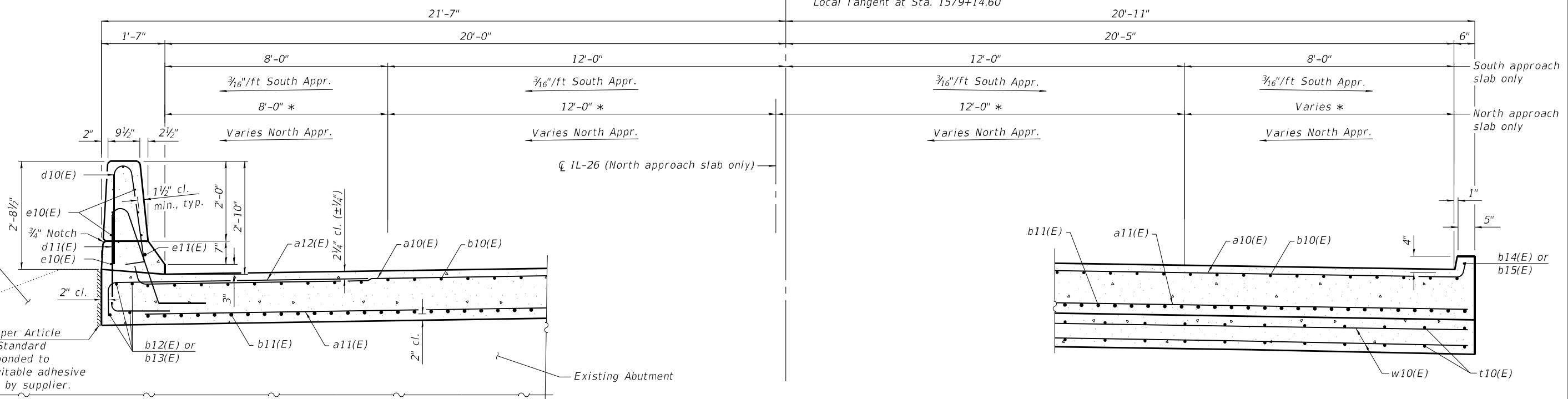

**CROSS SECTION**  
 (South approach slab shown; North approach slab similar)  
 (Looking South)

**AT APPROACH FOOTING**

MODEL: Default  
 FILE NAME: \\b501\Projects\2020\1011005 - PTB 194+29 D3 - ESCA - Various Phase - I\IWO#8 IL-26 BR Repairs\CADD\CADD Sheets\0060187-66M70-007-Appr1.dgn  
 1/9/2023 4:26:28 PM



USER NAME =	cslokes	DESIGNED -	CFS	REVISED -	
	0060187-66M70-007-Appr1.dgn	CHECKED -	KFO	REVISED -	
PLOT SCALE =	0:2.0000 "/td> <td>DRAWN -</td> <td>CFS</td> <td>REVISED -</td> <td></td>	DRAWN -	CFS	REVISED -	
PLOT DATE =	1/9/2023	CHECKED -	MDC	REVISED -	

**STATE OF ILLINOIS  
DEPARTMENT OF TRANSPORTATION**

**BRIDGE APPROACH SLAB DETAILS  
STRUCTURE NO. 006-0187**

SHEET 7 OF 9 SHEETS

F.A.P. RTE.	SECTION	COUNTY	TOTAL SHEETS	SHEET NO.
316	(116 BR)I	BUREAU	49	31
CONTRACT NO. 66M70				
ILLINOIS FED. AID PROJECT				

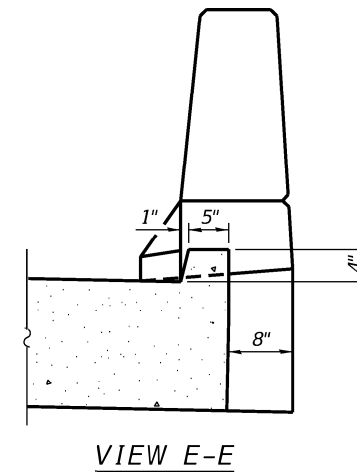
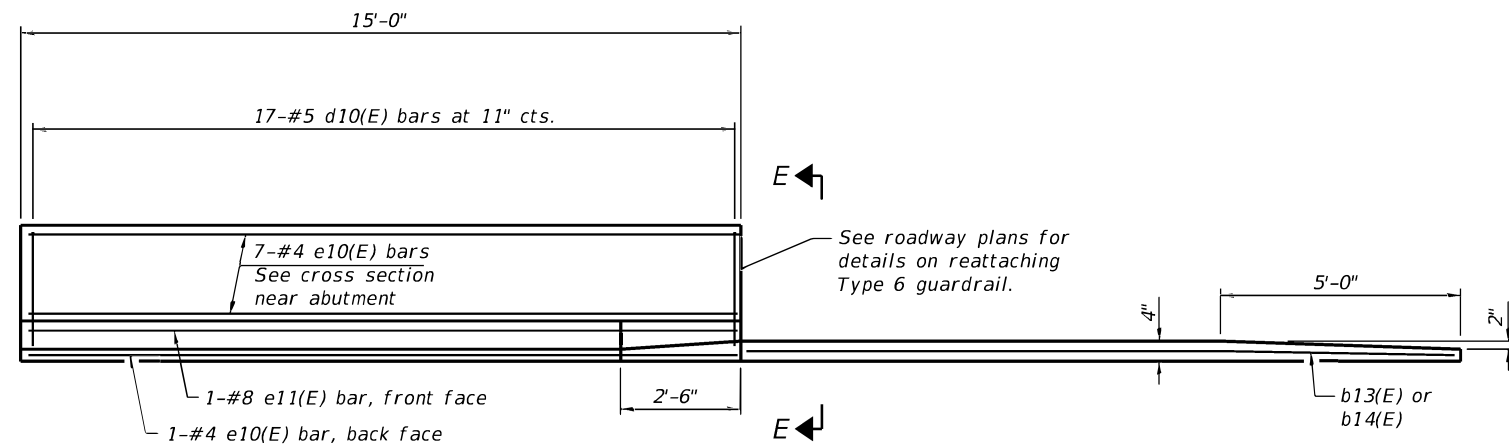

INSIDE ELEVATION OF PARAPET AND CURB

Notes:  
 The joint opening shall be adjusted for temperature per Article 520.04 of the Standard Specifications. However, since this detail is for jointless structures, the length of bridge used to calculate the adjustment shall be equal to half the total bridge length plus the length of the bridge approach slab.  
 Parapet concrete shall be paid for as Concrete Superstructure.  
 Approach slab shall be paid for as Concrete Superstructure (Approach Slab).  
 Approach footing concrete shall be paid for as Concrete Structures.  
 The approach footing maximum applied service bearing pressure ( $Q_{max}$ ) = 2.0 ksf.  
 Cost of excavation for approach footing included with Concrete Structures.

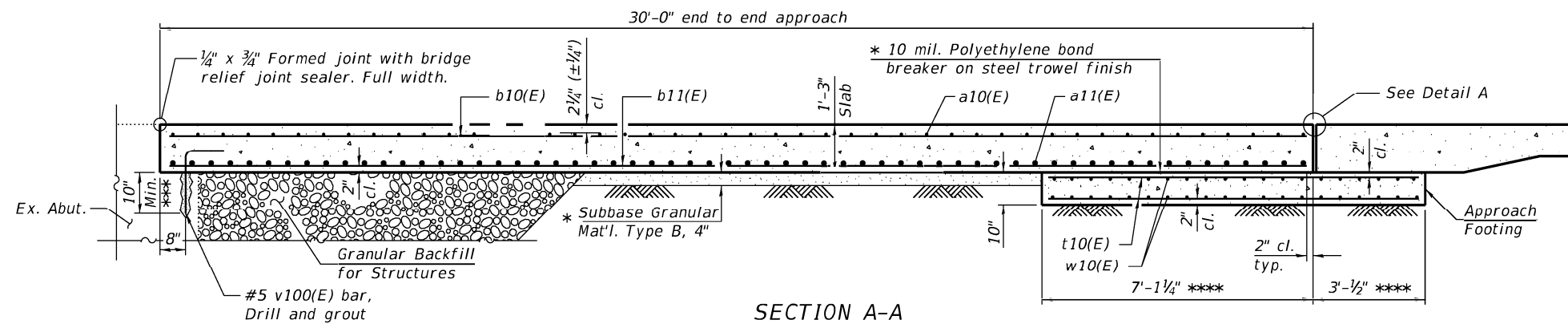

SECTION A-A

\*\*\* Follow manufacturers guideline on grout depth required for strength.  
 \*\*\*\* Measured along  $\varnothing$  Structure.

TWO APPROACHES  
 BILL OF MATERIAL

Bar	No.	Size	Length	Shape
a10(E)	184	#5	21'-5"	┌───┐
a11(E)	240	#8	20'-11"	┌───┐
a12(E)	92	#5	7'-4"	┌───┐
b10(E)	124	#5	29'-8"	┌───┐
b11(E)	200	#9	29'-8"	┌───┐
b12(E)	8	#5	14'-10"	┌───┐
b13(E)	8	#5	14'-5"	┌───┐
b14(E)	2	#4	14'-6"	┌───┐
b15(E)	2	#4	14'-9"	┌───┐
d10(E)	68	#5	5'-7"	┌───┐
d11(E)	68	#5	7'-8"	┌───┐
e10(E)	32	#4	14'-8"	┌───┐
e11(E)	4	#8	14'-8"	┌───┐
t10(E)	176	#4	9'-9"	┌───┐
w10(E)	160	#5	20'-11"	┌───┐
v100(E)	88	#5	2'-8"	┌───┐
Concrete Superstructure			Cu. Yd.	6.7
Concrete Structures			Cu. Yd.	26.3
Reinforcement Bars, Epoxy Coated			Pound	48,810
Concrete Superstructure (Approach Slab)			Cu. Yd.	118.1

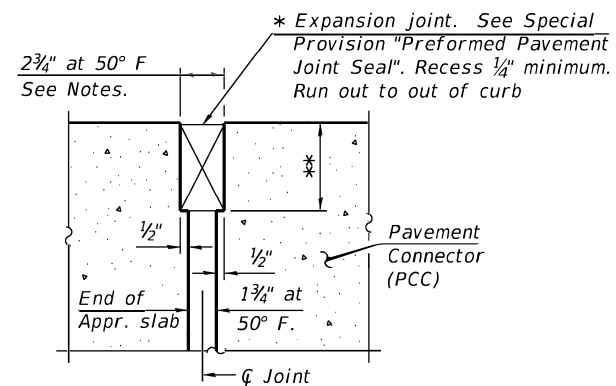

DETAIL A  
 (at Rt. L's)

\*\* Per manufacturer recommendations

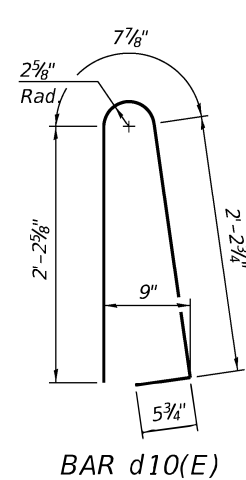

BAR d10(E)

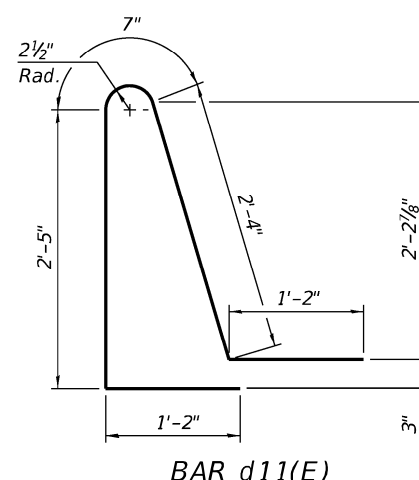

BAR d11(E)

BAR v100(E)

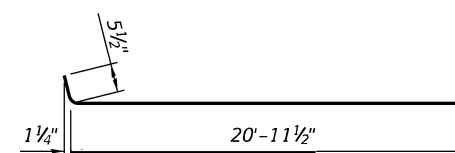

BAR a10(E)

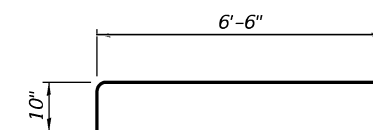

BAR a12(E)

MODEL: Default  
 FILE NAME: \\bs01\Projects\2020\201005 - PTB 194-29 D3 - ESCA - Various Phase I\IWO#8 IL-26 BR Repairs\CADD Sheets\0060187-66M70-008-Appr2.dgn  
 1/9/2023 4:26:30 PM



USER NAME = cstokes	DESIGNED - CFS	REVISED -
0060187-66M70-008-Appr2.dgn	CHECKED - KFO	REVISED -
PLOT SCALE = 0:2.0000 "/>		

STATE OF ILLINOIS  
 DEPARTMENT OF TRANSPORTATION

BRIDGE APPROACH SLAB DETAILS  
 STRUCTURE NO. 006-0187

SHEET 8 OF 9 SHEETS

F.A.P. RTE.	SECTION	COUNTY	TOTAL SHEETS	SHEET NO.
316	(116 BR)	BUREAU	49	32
CONTRACT NO. 66M70				

ILLINOIS FED. AID PROJECT



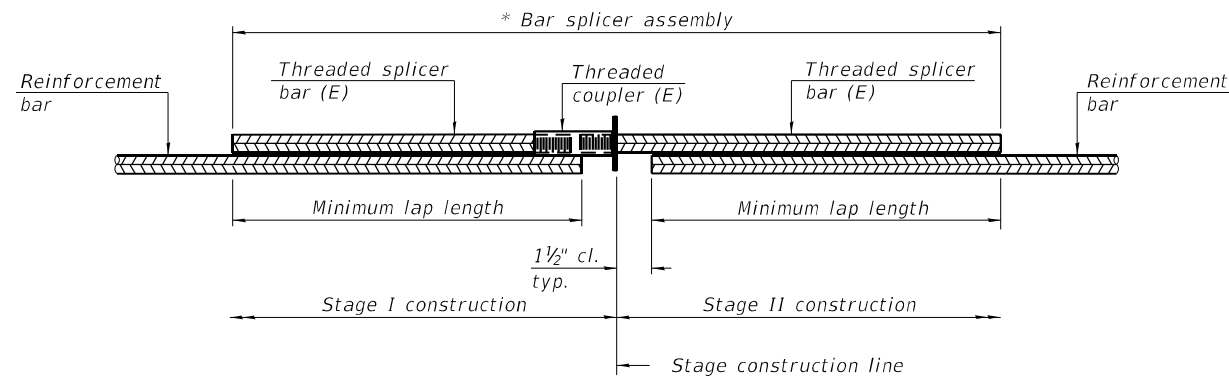

**STANDARD BAR SPLICER ASSEMBLY PLAN**  
 (All components shall be provided from one supplier)

Threaded splicer bar length = min. lap length + 1 1/2" + thread length

\* Epoxy not required on Bar Splicer Assembly components used in conjunction with black bars.

Location	Bar size	No. assemblies required	Minimum lap length
Approach Slab	#5	92	3'-4"
Approach Slab	#8	120	4'-9"
Approach Footing	#5	80	3'-2"

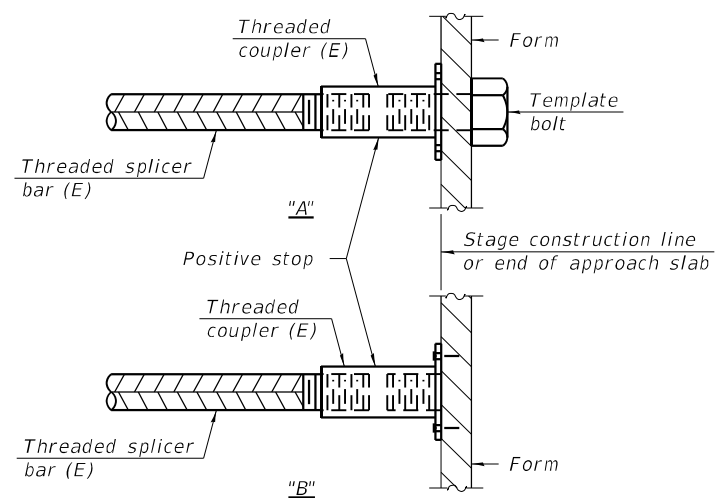

**INSTALLATION AND SETTING METHODS**

"A" : Set bar splicer assembly by means of a template bolt.  
 "B" : Set bar splicer assembly by nailing to wood forms or cementing to steel forms.  
 (E) : Indicates epoxy coating.

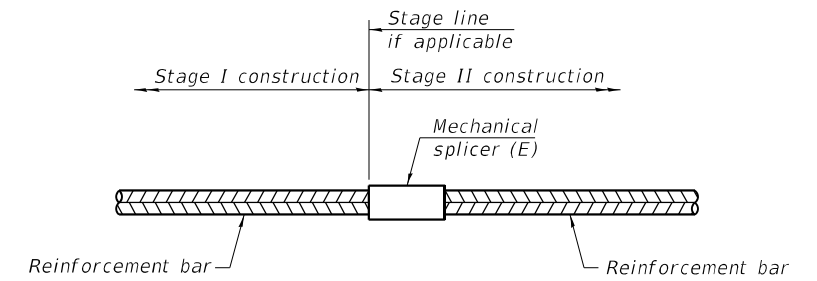

**STANDARD MECHANICAL SPLICER**

Location	Bar size	No. assemblies required

Notes:  
 Splicer bars shall be deformed with threaded ends and have a minimum 60 ksi yield strength.  
 All reinforcement shall be lapped and tied to the splicer bars.  
 Bar splicer assemblies shall be epoxy coated according to the requirements for reinforcement bars. See Section 508 of the Standard Specifications.  
 See approved list of bar splicer assemblies and mechanical splicers for alternatives.

MODEL: Default  
 FILE NAME: \\bs01\Projects\2020\2011005 - PTB 194+29 D3 - ESCA - Various Phase I\IWO#8 IL-26 BR Repairs\CADD\CADD\_Sheets\0060187-66M70-009-Splicer.dgn

BSD-1

1-1-2020



USER NAME = cstokes	DESIGNED - CFS	REVISED -
0060187-66M70-009-Splicer.dgn	CHECKED - KFO	REVISED -
PLOT SCALE = 0:2.0000 " = 1/16"	DRAWN - CFS	REVISED -
PLOT DATE = 1/9/2023	CHECKED - MDC	REVISED -

STATE OF ILLINOIS  
 DEPARTMENT OF TRANSPORTATION

BAR SPLICER ASSEMBLY AND MECHANICAL SPLICER DETAILS  
 STRUCTURE NO. 006-0187

SHEET 9 OF 9 SHEETS

F.A.P. RTE. 316	SECTION (116 BR)I	COUNTY BUREAU	TOTAL SHEETS 49	SHEET NO. 33
CONTRACT NO. 66M70				
ILLINOIS FED. AID PROJECT				

Benchmarks: #1, Dier on Northwest Headwall of Structure No. 006-0136, Elevation = 636.75 (NAVD 88), Sta. 1579+30.66/17.13' RT.  
 #2, Railroad Spike in power pole approximately 750' North of E of Big Bureau Creek, Elevation = 630.65 (NAVD 88), Sta. 1573+06.22/50.19' RT.

Existing Structure: Structure No. 006-0079 was originally built in 1927 as SBI Route 69, Section 115B. In 1981, the superstructure was replaced, the North abutment was replaced and relocated, and the remaining substructure was widened to build Structure No. 006-0136 as FA Route 316, Section 115B. In 1993, the existing bituminous wearing surface was removed and replaced with a 3" reinforced concrete wearing surface as FA Route 316, Section 115B-M. The superstructure consists of a four-span, precast prestressed concrete deck beam bridge with a 5" reinforced concrete wearing surface. The substructure consists of an open pile bent abutment of the North end supported by precast concrete piles, a closed abutment wall at the south and supported by unfracted timber piles, and solid wall pier piers supported by unfracted timber piles and precast concrete piles. The back-to-back of abutment dimension measures 228'-1" and the out-to-out dimension measures 33'-0". The span lengths are 87'-8", 53'-0", 53'-0", and 54'-5". The structure is not skewed. One lane of traffic will be maintained utilizing stage construction.

No Salvage.

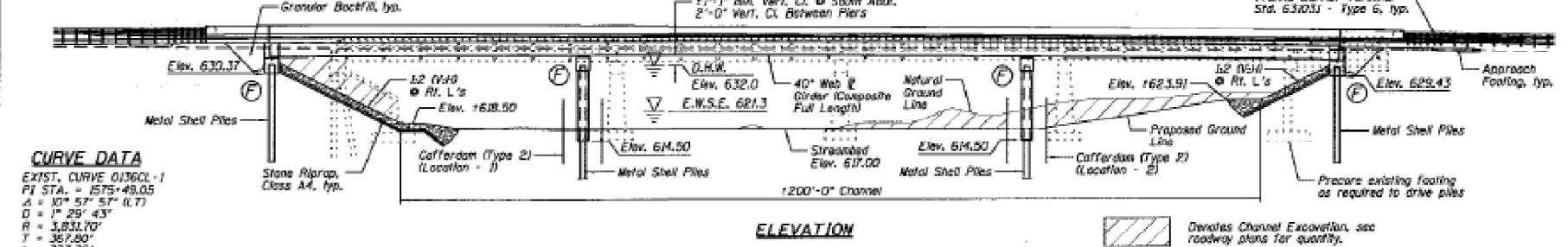

**CURVE DATA**  
 EXIST. CURVE 0136CL-1  
 P.I. STA. = 1575+49.05  
 Δ = 10° 59' 57" (L.T.)  
 D = 1" 29' 43"  
 R = 3,031.70'  
 T = 367.80'  
 L = 733.35'  
 E = 17.61'  
 e = 3.20%  
 T.A. = 38°  
 S.E. P.W. = 82°  
 FULL SUPER from STA. 1575+50.00  
 to STA. 1578+87.54  
 S.E. TRANS. from STA. 1578+87.54  
 to STA. 1580+07.54  
 P.C. STA. = 1571+81.25  
 P.T. STA. = 1579+14.50

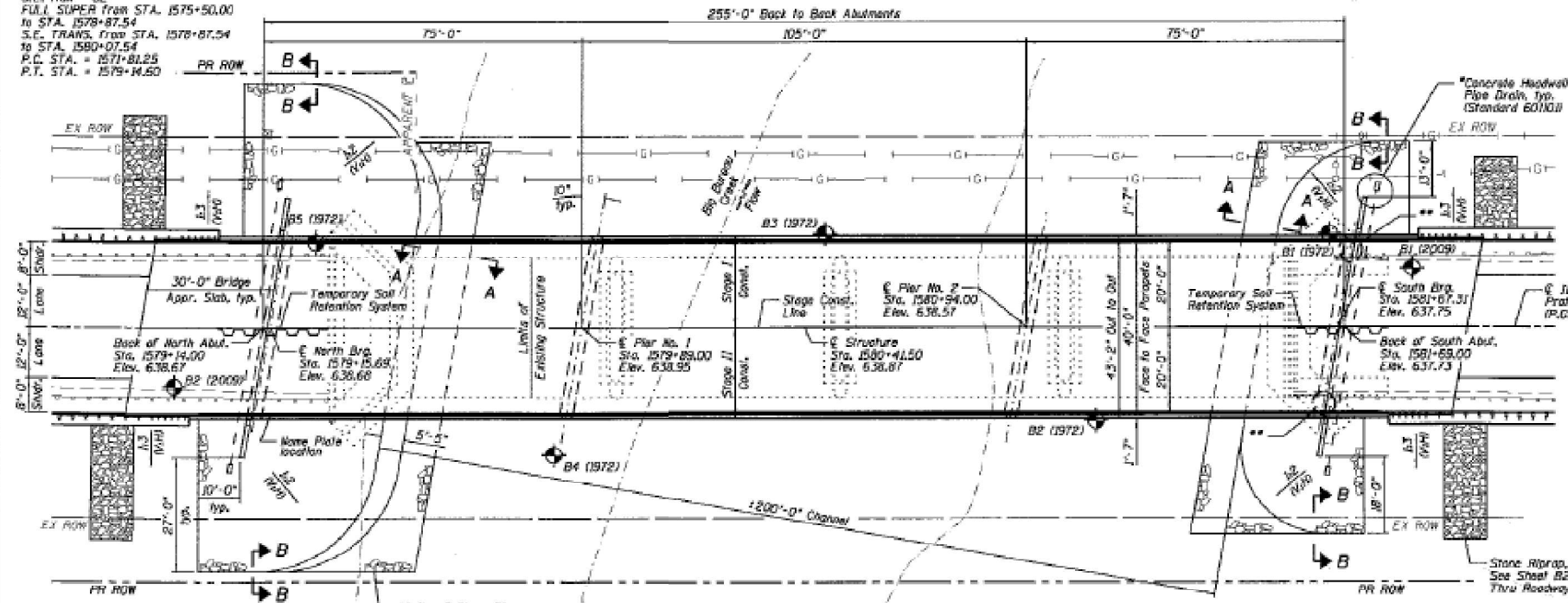

**NOTE:**  
 See Sheet B2 for Section A-A and B-B.

**LOADING HL-93**  
 Allow 50#/sq. ft. for future wearing surface.

**DESIGN SPECIFICATIONS**  
 2014 AASHTO LRFD Bridge Design Specifications, Customary U.S. Units, 7th Edition

**DESIGN STRESSES**  
 FIELD UNITS:  
 F<sub>c</sub> = 3,500 psi  
 F<sub>y</sub> = 60,000 psi (Reinforcement)  
 F<sub>y</sub> = 50,000 psi (AASHTO M270 Grade 50W)

**SEISMIC DATA**  
 Seismic Performance Zone (SPZ) = 1  
 Design Spectral Acceleration at 1.0 sec. (SDS) = 0.067  
 Design Spectral Acceleration at 0.2 sec. (SDS) = 0.116  
 Soil Site Class = C

**APPROVED**  
 For Structural Adequacy Only  
 Joseph M. Lowrance  
 Engineer of Bridges & Structures



**WATERWAY INFORMATION**

Drainage Area = 175.5 Sq. Mi. Existing Low Grade Elev. 629.83 @ Sta. 1597+25  
 Proposed Low Grade Elev. 629.83 @ Sta. 1597+25

Flood	Yr.	C.F.S.	Exist. Elev.	Prop. Elev.	H.W.F. Exist.	H.W.F. Prop.	Head - Ft. Exist.	Head - Ft. Prop.	Headwater EL. Exist.	Headwater EL. Prop.
Ex. Overlapping	9	7,490	1,455	2,541	629.7	0.4	0.0	0.0	630.1	629.7
Pr. Overlapping	9	7,330	1,460	2,557	629.8	0.4	0.0	0.0	630.2	629.8
Hydraulic Design	10	7,920	1,504	2,500	630.0	0.5	0.1	0.5	630.4	630.1
Base/Scour Design	100	14,500	2,042	3,111	632.7	0.3	0.3	0.3	633.0	633.0
Scour Check	200	16,570	2,121	3,351	633.2	0.5	0.4	0.4	633.7	633.6
Max. Dis.	500	19,300	3,522	3,493	633.8	0.6	0.4	0.4	634.4	634.2

10-Yr. Velocity = 5.3 ft./sec. (Exist.)  
 10-Yr. Velocity = 3.0 ft./sec. (Prop.)

**DESIGN SCOUR ELEVATION TABLE**

Event/At. Int.	Design Scour Elevations (ft.)				Item #1
	N. Abut.	Pier 1	Pier 2	S. Abut.	
1000	630.4	611.9	611.9	629.4	8
0200	630.4	611.9	611.9	629.4	
Design	630.4	611.9	611.9	629.4	
Check	630.4	611.9	611.9	629.4	

**INDEX OF SHEETS**

SHEET NO.	TITLE
B1	GENERAL PLAN AND ELEVATION
B2	GENERAL DATA
B3	STAGE CONSTRUCTION DETAILS
B4	TEMPORARY CONCRETE BARRIER FOR STAGE CONSTRUCTION
B5	TOP OF DECK ELEVATION LOCATIONS
B6-B7	TOP OF DECK ELEVATIONS
B8	TOP OF APPROACH SLAB ELEVATIONS
B9	SUPERSTRUCTURE
B10	SUPERSTRUCTURE DETAILS
B11-B12	DIAPHRAGM DETAILS
B13-B16	PRECAST BRIDGE APPROACH SLAB
B17-B19	STRUCTURAL STEEL
B20	FIXED BEARING DETAILS
B21	NORTH ABUTMENT
B22	SOUTH ABUTMENT
B23	PIER NO. 1
B24	PIER NO. 2
B25	METAL SHELL PILE DETAILS
B26	BAR SPLICER ASSEMBLY AND MECHANICAL SPLICER DETAILS
B27	CONCRETE PARAPET SLIPFORMING OPTION
B28-B32	SOIL BORING LOGS

Joseph M. Lowrance  
 ILLINOIS STRUCTURAL ENGINEER  
 No. 081-006446  
 Exp. Date 11/30/18



DESIGNED - TOR/JCZ	REVISED
CHECKED - JML	REVISED
DRAWN - DJM	REVISED
DATE = 07/28/17	CHECKED - JML
	REVISED

STATE OF ILLINOIS  
 DEPARTMENT OF TRANSPORTATION

SHEET NO. B1 OF 32 SHEETS

F.A.P. RTE.	SECTION	COUNTY	TOTAL SHEETS	SHEET NO.
316	(116 BR)R	BUREAU	49	34
CONTRACT NO. 66A19			ILLINOIS FED. AID PROJECT	

**FOR INFORMATION ONLY**

**EAST CURB LINE / EAST FACE OF PARAPET**

Location	Station	Offset	Theoretical Grade Elevation
N. End of North Appr.	1578+88.48	-20.33	637.82
A	1578+98.53	-20.38	637.99
B	1579+08.51	-20.00	638.16
S. End of North Appr.	1579+18.54	-20.00	638.30

**EAST EDGE OF PAVEMENT**

Location	Station	Offset	Theoretical Grade Elevation
N. End of North Appr.	1578+87.06	-12.00	638.07
A	1578+97.08	-12.00	638.20
B	1579+07.11	-12.00	638.33
S. End of North Appr.	1579+17.14	-12.00	638.45

**ROADWAY PROFILE GRADE LINE (P.G.L.) & STAGE CONSTRUCTION LINE**

Location	Station	Offset	Theoretical Grade Elevation
N. End of North Appr.	1578+85.04	0.00	638.44
A	1578+95.02	0.00	638.53
B	1579+05.02	0.00	638.61
S. End of North Appr.	1579+15.02	0.00	638.68

**WEST EDGE OF PAVEMENT**

Location	Station	Offset	Theoretical Grade Elevation
N. End of North Appr.	1578+83.02	12.00	638.80
A	1578+92.98	12.00	638.87
B	1579+02.94	12.00	638.90
S. End of North Appr.	1579+12.90	12.00	638.93

**WEST CURB LINE / WEST FACE OF PARAPET**

Location	Station	Offset	Theoretical Grade Elevation
N. End of North Appr.	1578+81.59	20.56	639.06
A	1578+91.54	20.49	639.12
B	1579+01.56	20.02	639.11
S. End of North Appr.	1579+11.51	20.00	639.10

**NOTE:**  
Offset dimensions @ Rt. L's to Roadway & Profile Grade Line (P.G.L.)

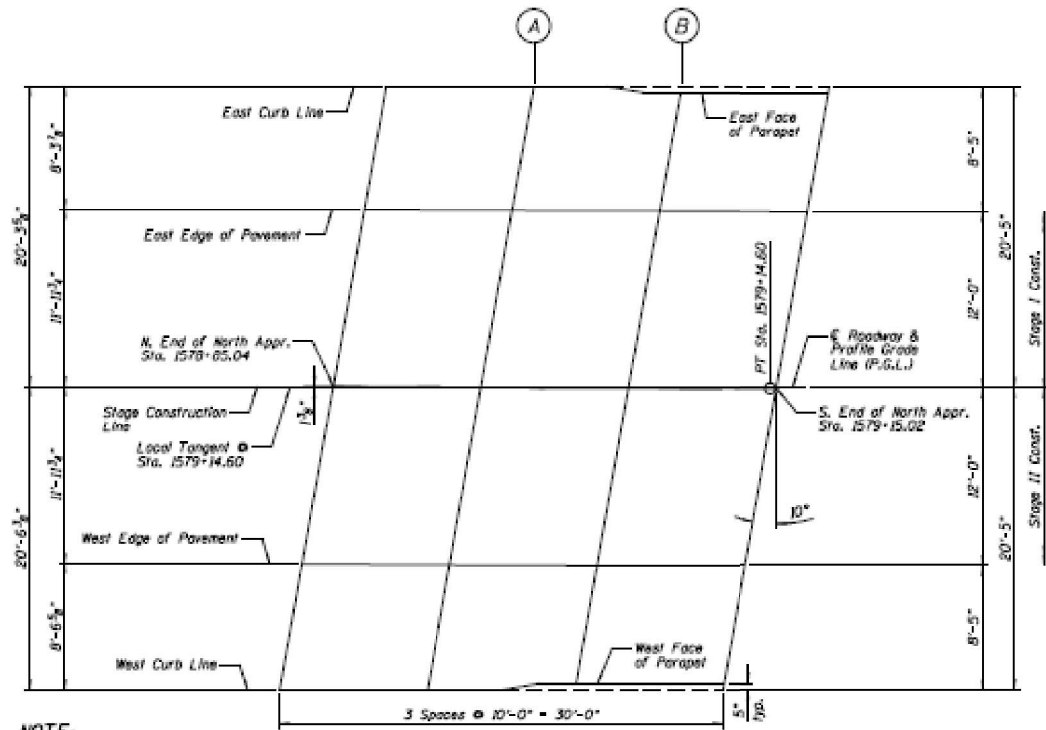

**NOTE:**  
Transverse dimensions @ Rt. L's to the Local Tangent @ Sta. 1579+14.60.

**NORTH APPROACH SLAB PLAN**

**EAST CURB LINE / EAST FACE OF PARAPET**

Location	Station	Offset	Theoretical Grade Elevation
N. End of South Appr.	1581+71.51	-20.00	637.38
A	1581+81.51	-20.00	637.23
B	1581+91.58	-20.42	637.07
S. End of South Appr.	1582+01.58	-20.42	636.90

**EAST EDGE OF PAVEMENT**

Location	Station	Offset	Theoretical Grade Elevation
N. End of South Appr.	1581+70.10	-12.00	637.53
A	1581+80.10	-12.00	637.38
B	1581+90.10	-12.00	637.22
S. End of South Appr.	1582+00.10	-12.00	637.06

**ROADWAY PROFILE GRADE LINE (P.G.L.) & STAGE CONSTRUCTION LINE**

Location	Station	Offset	Theoretical Grade Elevation
N. End of South Appr.	1581+67.98	0.00	637.74
A	1581+77.98	0.00	637.60
B	1581+87.98	0.00	637.44
S. End of South Appr.	1581+97.98	0.00	637.28

**WEST EDGE OF PAVEMENT**

Location	Station	Offset	Theoretical Grade Elevation
N. End of South Appr.	1581+65.87	12.00	637.59
A	1581+75.87	12.00	637.44
B	1581+85.87	12.00	637.29
S. End of South Appr.	1581+95.87	12.00	637.13

**WEST CURB LINE / WEST FACE OF PARAPET**

Location	Station	Offset	Theoretical Grade Elevation
N. End of South Appr.	1581+64.46	20.00	637.48
A	1581+74.46	20.00	637.34
B	1581+84.38	20.42	637.18
S. End of South Appr.	1581+94.38	20.42	637.02

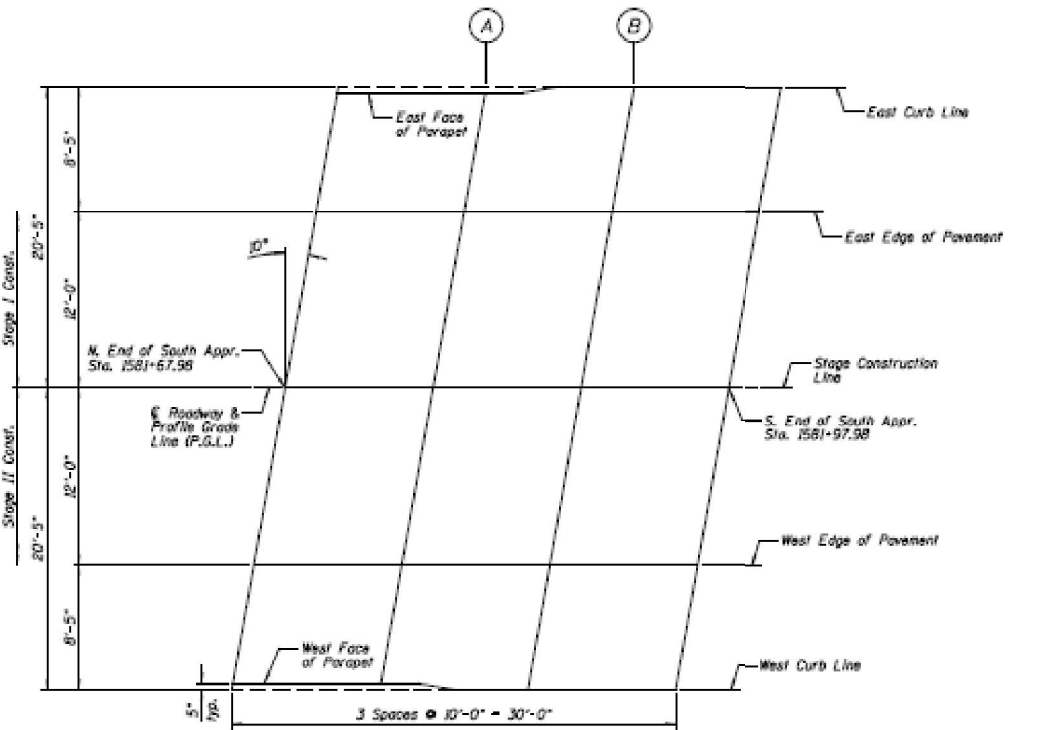

**SOUTH APPROACH SLAB PLAN**



DESIGNED - TOR/JCZ	REVISION
CHECKED - JML	REVISION
DRAWN - DJM	REVISION
CHECKED - JML	REVISION
DATE - 07/28/17	

**STATE OF ILLINOIS  
DEPARTMENT OF TRANSPORTATION**

**TOP OF APPROACH SLAB ELEVATIONS  
STRUCTURE NO. 005-0187  
SHEET NO. 88 OF 12 SHEETS**

F.A.P. RTE.	SECTION	COUNTY	TOTAL SHEETS	SHEET NO.
316	(16 BR1)	BUREAU	91	41
CONTRACT NO. 66A19			ILLINOIS FED. AID PROJECT	

**FOR INFORMATION ONLY**

FILE NAME :	USER NAME : TroyHart	DESIGNED :	REVISION :
pw:/1ldot-pw.bentley.com/PWIDOT/Documents/IDOT Offices/District 3/ORD Projects/D36670/Drawings/CAOSheets/D366M70-sht-detail.dwg		CHECKED :	REVISION :
PLOT SCALE = 100.000' / 1"		DATE :	REVISION :
PLOT DATE = 2/9/2023			

**STATE OF ILLINOIS  
DEPARTMENT OF TRANSPORTATION**

SCALE:	SHEET NO. OF SHEETS	STA. TO STA.
--------	---------------------	--------------

F.A.P. RTE.	SECTION	COUNTY	TOTAL SHEETS	SHEET NO.
316	(16 BR1)	BUREAU	49	35
CONTRACT NO. 66M70			ILLINOIS FED. AID PROJECT	

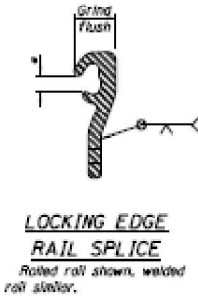
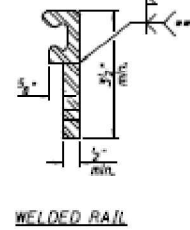
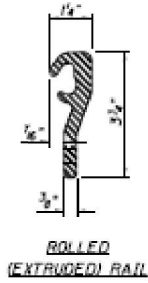
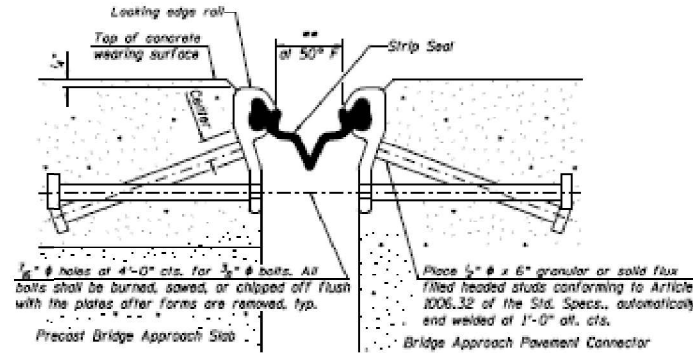
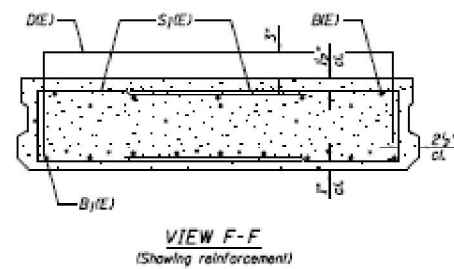
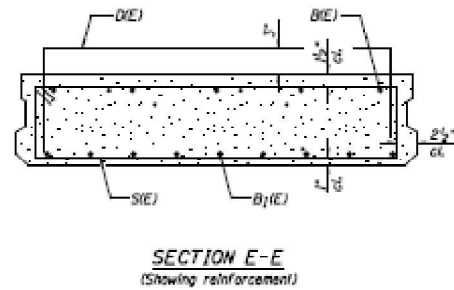
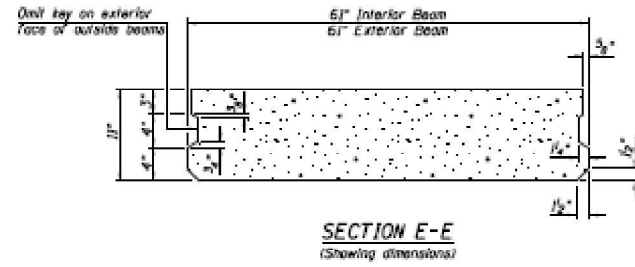
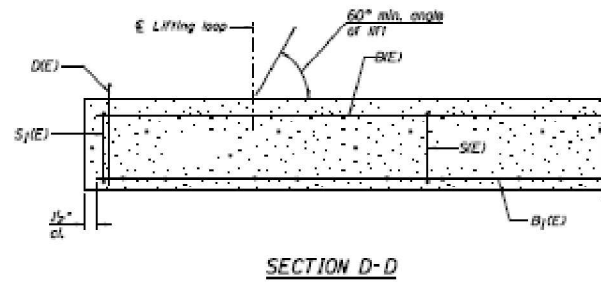

**LOCKING EDGE RAIL**

- Omit weld at seal opening.
- \*\* The joint opening shall be determined per Article 520.04 except that on jointless structures, the distance between the bridge length between the nearest fixed bearings each way from the joint shall be taken as half the bridge length plus the approach slab length. The minimum dimension shall be 1 1/2' for installation purposes.
- \*\*\* Back gauge not required if complete joint penetration is verified by mock-up.

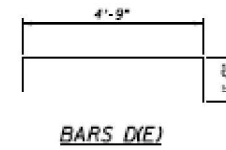
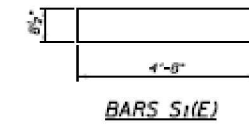
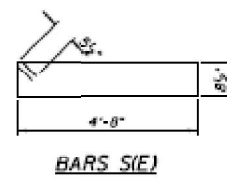

**BAR LIST**  
EACH INTERIOR BEAM  
(For information only)

Bar	No.	Size	Length	Shape
B1(E)	5	#5	29'-8"	—
S1(E)	12	#5	29'-8"	—
D1E	22	#4	6'-9"	□
S1E	58	#5	11'-8"	□
S1(E)	4	#5	10'-0"	□

**BAR LIST**  
EACH EXTERIOR BEAM  
(For information only)

Bar	No.	Size	Length	Shape
B1(E)	5	#5	29'-8"	—
S1(E)	12	#5	29'-8"	—
D1E	12	#4	6'-9"	□
S1E	58	#5	11'-8"	□
S1(E)	4	#5	10'-0"	□

**Notes:**

- The precast bridge approach slab shall be according to Section 504 of the Standard Specifications and shall be paid for at the contract unit price per square foot for Precast Bridge Approach Slab.
- Cast-in-place substitution of Precast Bridge Approach Slab is not allowed.
- Parapet concrete shall be paid for as Concrete Superstructure.
- Parapet and wearing surface reinforcement shall be paid for as Reinforcement Bars, Epoxy Coated.
- Approach footing concrete shall be paid for as Concrete Structures.
- The top surface of precast bridge approach slabs shall be roughened to a depth of 1/4" according to the IDOT Manual for Fabrication of Precast Prestressed Concrete Products.
- After precast bridge approach slab has been erected, holes shall be drilled into abutment and anchor dowels placed. Dowel holes shall be filled with non-shrink grout to top of precast slab and allowed to cure fully prior to grouting the longitudinal shear keys.
- Two 1/2" fabric adjusting shims of the dimensions of the exterior bearing pad shall be provided for each bearing pad location. Cast included with Precast Bridge Approach Slab.
- A minimum 2 1/2" # lifting pins shall be used to engage the lifting loops during handling.
- Compressive strength of precast concrete, f'c shall be 5,000 psi.
- Compressive strength of precast concrete during initial lifting, f'ci shall be 5,000 psi.
- For additional parapet details, see Sheet B10.
- Any concrete poured monolithically with the wearing surface, such as curbs, will not be paid for separately, but will be included in the cost of Concrete Wearing Surface, 5'.
- The strip seal shall be made continuous and shall have a minimum thickness of 1/4". The strip seal shall extend 6" beyond the edge of the approach slab on each end. The configuration of the strip seal shall match the configuration of the Locking Edge Rails. Open or "webbed" strip seal gland configurations are not permitted. The gland shall be sized for a maximum rated movement of 4 inches.
- The Locking Edge Rails depicted are conceptual only, except for the minimum dimensions shown. The actual configuration of the Locking Edge Rails and matching strip seal may vary from manufacturer to manufacturer. Flanged edge rails will not be allowed.
- The inside of the Locking Edge Rail groove shall be free of weld residue.
- Locking Edge Rails may be spliced at slope discontinuities and stage construction joints.
- The manufacturer's recommended installation methods shall be followed.
- All steel components shall be galvanized after fabrication according to Article 520.03 of the Standard Specifications.
- Maximum space between rail segments at slope lines shall be 1/8", sealed with a suitable sealant. Joints in rails within 10 ft. of curbs shall be welded.

**TWO APPROACHES**  
**BILL OF MATERIAL**

Bar	No.	Size	Length	Shape
d1E)	124	#4	21'-3"	—
d1E)	60	#4	7'-5"	—
b1E)	8	#4	14'-8"	—
b1E)	84	#4	29'-8"	—
d1E)	68	#5	5'-7"	—
d1E)	68	#5	5'-11"	—
a1E)	32	#4	14'-8"	—
a1E)	4	#8	14'-8"	—
NE)	168	#4	9'-10"	—
w1E)	160	#5	20'-11"	—
Concrete Structures		Cu. Yd.	29.7	
Concrete Superstructure		Cu. Yd.	6.7	
Bridge Deck Grooving		Sq. Yd.	255	
Protective Coat		Sq. Yd.	300	
Reinforcement Bars, Epoxy Coated		Pound	9,680	
Preformed Joint Strip Seal		Foot	87	
Concrete Wearing Surface, 5"		Sq. Yd.	283	
Precast Bridge Approach Slab		Sq. Ft.	2,440	

(Beams: 36" min. width; 72" max. width)

(Sheet 4 of 4)

<p>2709 BUCKINGHAM DRIVE BLOOMINGTON, ILLINOIS 61704 618-244-8800   info@farnsworth.com</p>	DESIGNED - TCR/JCZ	REVISIONS	<p><b>STATE OF ILLINOIS</b> <b>DEPARTMENT OF TRANSPORTATION</b></p> <p>PRECAST BRIDGE APPROACH SLAB STRUCTURE NO. 006-0187</p> <p>SHEET NO. 816 OF 32 SHEETS</p>	<table border="1"> <tr> <th>DATE</th> <th>BY</th> <th>REVISION</th> </tr> <tr> <td>07/28/17</td> <td>JWL</td> <td>CHECKED</td> </tr> </table>	DATE	BY	REVISION	07/28/17	JWL	CHECKED	<table border="1"> <tr> <th>SECTION</th> <th>COUNTY</th> <th>TOTAL SHEETS</th> <th>SHEET NO.</th> </tr> <tr> <td>016 BRBR</td> <td>BUREAU</td> <td>49</td> <td>49</td> </tr> <tr> <td colspan="2">CONTRACT NO. 66A19</td> <td colspan="2">ILLINOIS FED. AID PROJECT</td> </tr> </table>	SECTION	COUNTY	TOTAL SHEETS	SHEET NO.	016 BRBR	BUREAU	49	49	CONTRACT NO. 66A19		ILLINOIS FED. AID PROJECT	
	DATE	BY		REVISION																			
	07/28/17	JWL		CHECKED																			
SECTION	COUNTY	TOTAL SHEETS	SHEET NO.																				
016 BRBR	BUREAU	49	49																				
CONTRACT NO. 66A19		ILLINOIS FED. AID PROJECT																					
CHECKED - JWL	REVISIONS	CONTRACT NO. 66A19																					
DRAWN - DJM	REVISIONS																						

**FOR INFORMATION ONLY**

FILE NAME:	USER NAME: TroyHart	DESIGNED:	REVISIONS:	<p><b>STATE OF ILLINOIS</b> <b>DEPARTMENT OF TRANSPORTATION</b></p> <p>EXISTING STRUCTURE PLANS</p>	F.A.P. RTE.:	SECTION:	COUNTY:	TOTAL SHEETS:	SHEET NO.:
pw://idot-pw.bentley.com/PWIDOT/Documents/IDOT Offices/District 3/ORD Projects/D36670/Drawings/CAD/Sheets/D366M70-sht-detail	CHECKED:	REVISIONS:	316		016 BRBR	BUREAU	49	36	
PLOT SCALE = 100.000' / 1"	DRAWN:	REVISIONS:	CONTRACT NO. 66M70						

SCALE: SHEET NO. OF SHEETS STA. TO STA. ILLINOIS FED. AID PROJECT

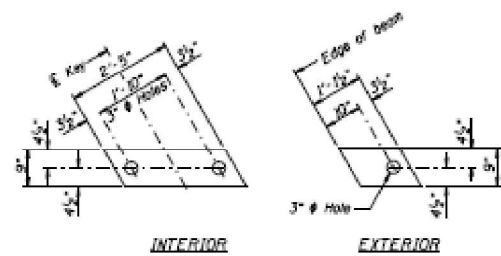

INTERIOR  
EXTERIOR  
**FABRIC BEARING PAD**

Notes:  
All bearing pads shall be 3/4" thick.  
Drill holes for fabric bearing pads at approach slab footing end of beams.  
Expansion bearing pad shall be bonded to the approach slab footing.

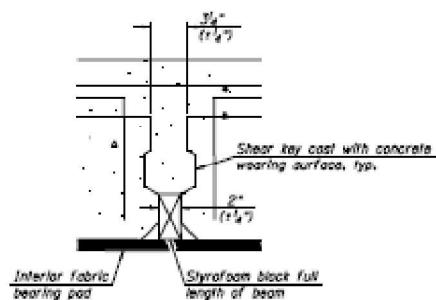

**SECTION THRU SHEAR KEY JOINT**

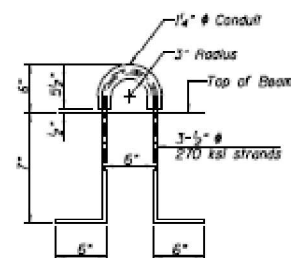

**LIFTING LOOP DETAIL**

(Beams .36" min. width; 72" max. width)

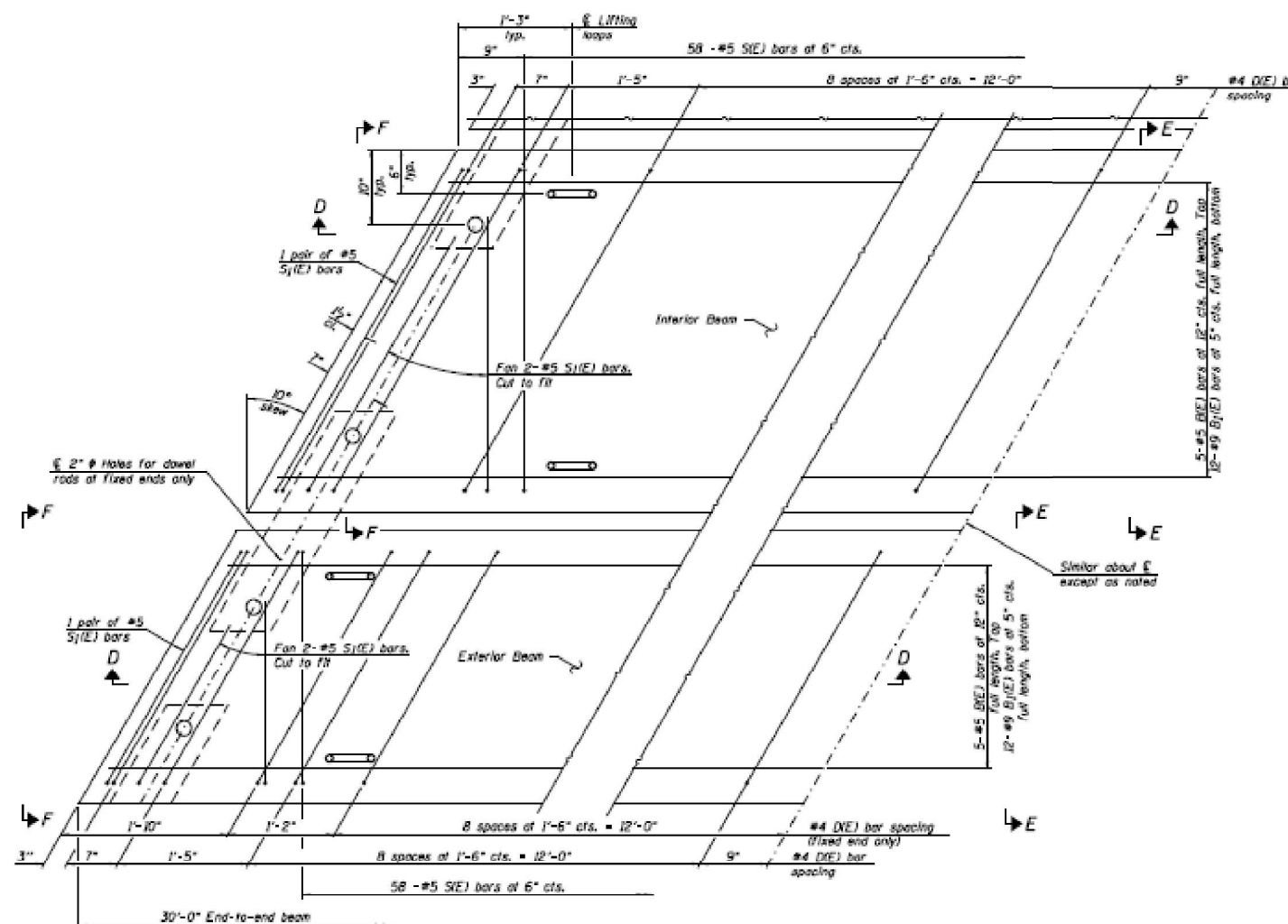

**PLAN VIEW**  
(showing precast bridge approach beams)

(Sheet 3 of 4)



DESIGNED - TCR/JEZ	REVISED
CHECKED - JML	REVISED
DRAWN - DJM	REVISED
DATE - 07/28/17	CHECKED - JML
	REVISED

STATE OF ILLINOIS  
DEPARTMENT OF TRANSPORTATION

PRECAST BRIDGE APPROACH SLAB  
STRUCTURE NO. 006-0187

SHEET NO. 315 OF 32 SHEETS

F.A.P. RTE.	SECTION	COUNTY	TOTAL SHEETS	SHEET NO.
315	(116 BR)R	BUREAU	32	48
			CONTRACT NO. 66A19	

24-8962

**FOR INFORMATION ONLY**

FILE NAME :	USER NAME : Troy.Hart	DESIGNED :	REVISED :
pw:/1ldot-pw.bentley.com/PW1007/Documents/IDOT Offices/District 3/ORD Projects/D36670/Drawings/CAOSheets/D366M70-sht-detail		CHECKED - JML	REVISED -
		DRAWN - DJM	REVISED -
		CHECKED -	REVISED -
		DATE -	REVISED -

STATE OF ILLINOIS  
DEPARTMENT OF TRANSPORTATION

EXISTING STRUCTURE PLANS

SCALE: SHEET NO. OF SHEETS STA. TO STA.

F.A.P. RTE.	SECTION	COUNTY	TOTAL SHEETS	SHEET NO.
316	(116 BR)I	BUREAU	49	37
			CONTRACT NO. 66M70	

ILLINOIS FED. AID PROJECT

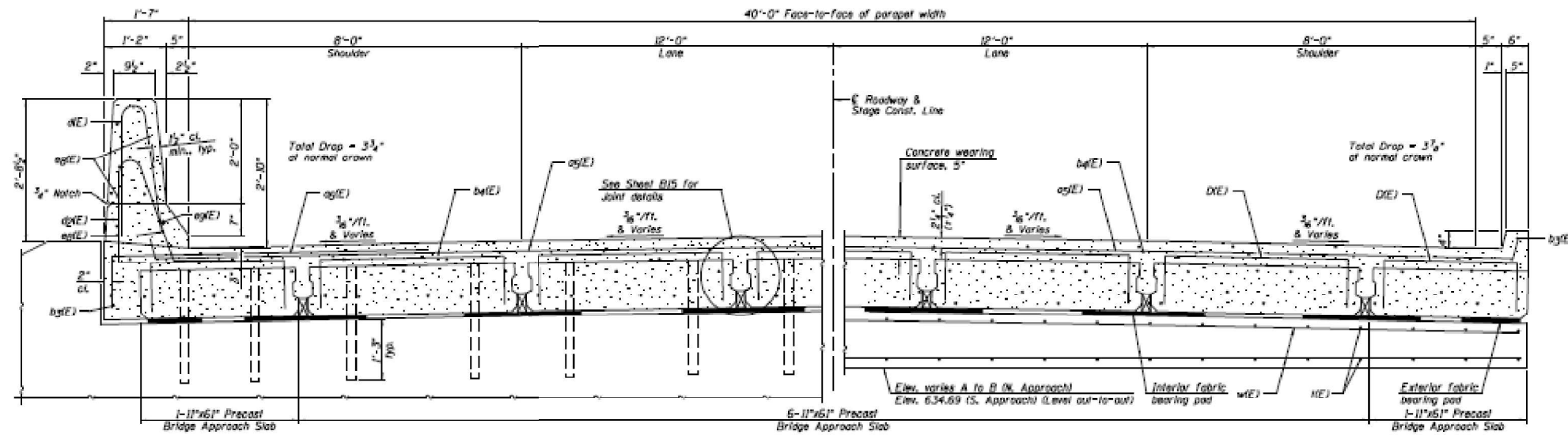

NEAR ABUTMENT

SECTION B-B

AT APPROACH FOOTING

Elevation	
A (West End)	B (East End)
636.05	635.62

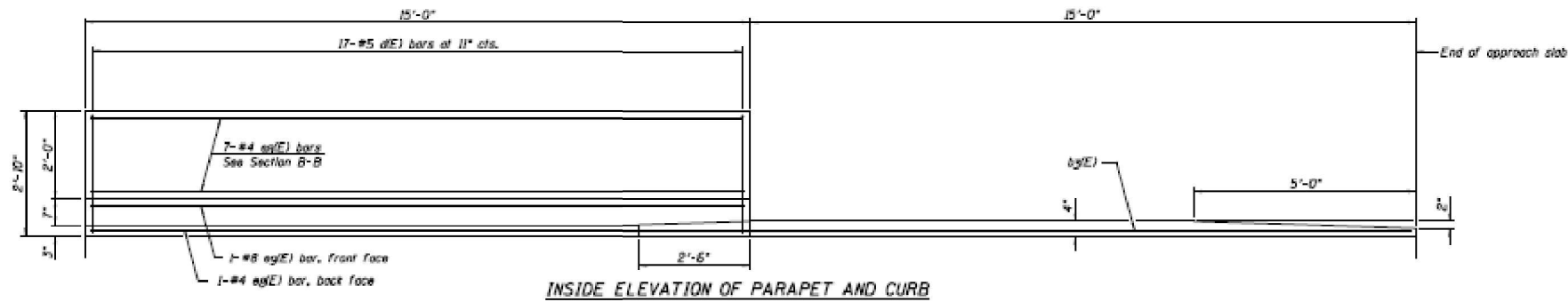

INSIDE ELEVATION OF PARAPET AND CURB

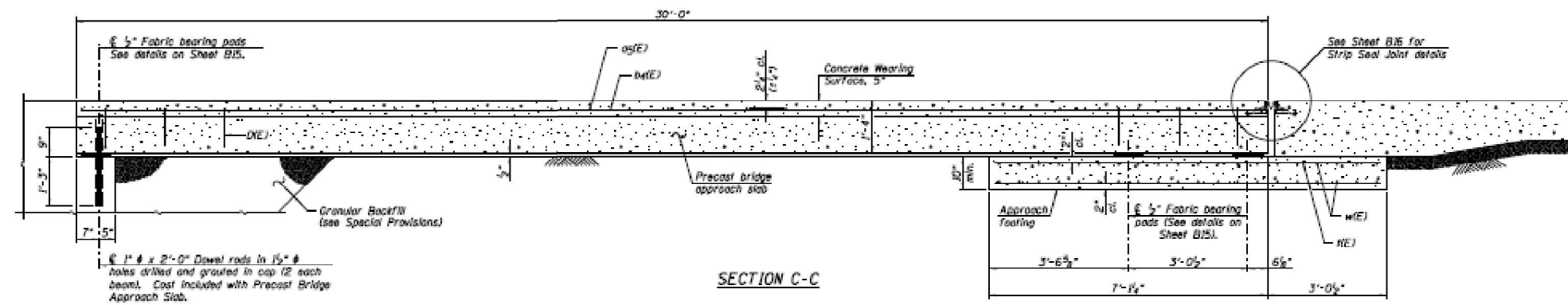

SECTION C-C

(Beams: 36" min. width; 72" max. width)

(Sheet 2 of 4)



DATE - 07/28/17

DESIGNED - TCR/JCZ	REVISED
CHECKED - JML	REVISED
DRAWN - DJM	REVISED
CHECKED - JML	REVISED

STATE OF ILLINOIS  
DEPARTMENT OF TRANSPORTATION

PRECAST BRIDGE APPROACH SLAB  
STRUCTURE NO. 006-0187  
SHEET NO. 814 OF 32 SHEETS

F.A.P. RTE.	SECTION	COUNTY	TOTAL SHEETS	SHEET NO.
316	016 BRBR	BUREAU	91	47
			CONTRACT NO. 66A19	

24-8962

**FOR INFORMATION ONLY**

FILE NAME :	USER NAME : TroyHart	DESIGNED :	REVISED :	<b>STATE OF ILLINOIS DEPARTMENT OF TRANSPORTATION</b>	<b>EXISTING STRUCTURE PLANS</b>	F.A.P. RTE.	SECTION	COUNTY	TOTAL SHEETS	SHEET NO.
pw:/idot-pw.bentley.com/PWIDOT/Documents/IDOT Offices/District 3/ORD Projects/D36670/Notes/CADsheets/D366M70-sht-detail	DRAWN :	REVISED :	316			016 BRB	BUREAU	49	38	
PLOT SCALE = 100.000 / 1" = 100'-0"	CHECKED :	REVISED :	CONTRACT NO. 66M70							
PLOT DATE = 2/9/2023	DATE :	REVISED :	ILLINOIS FED. AID PROJECT							

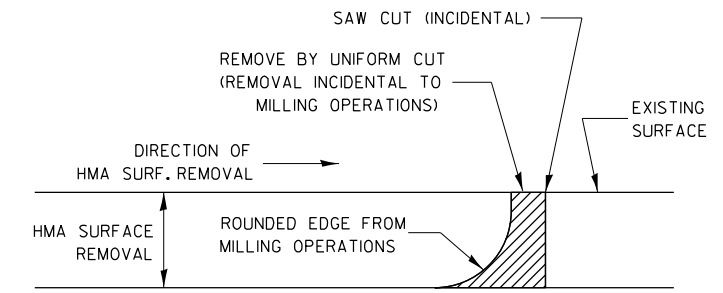
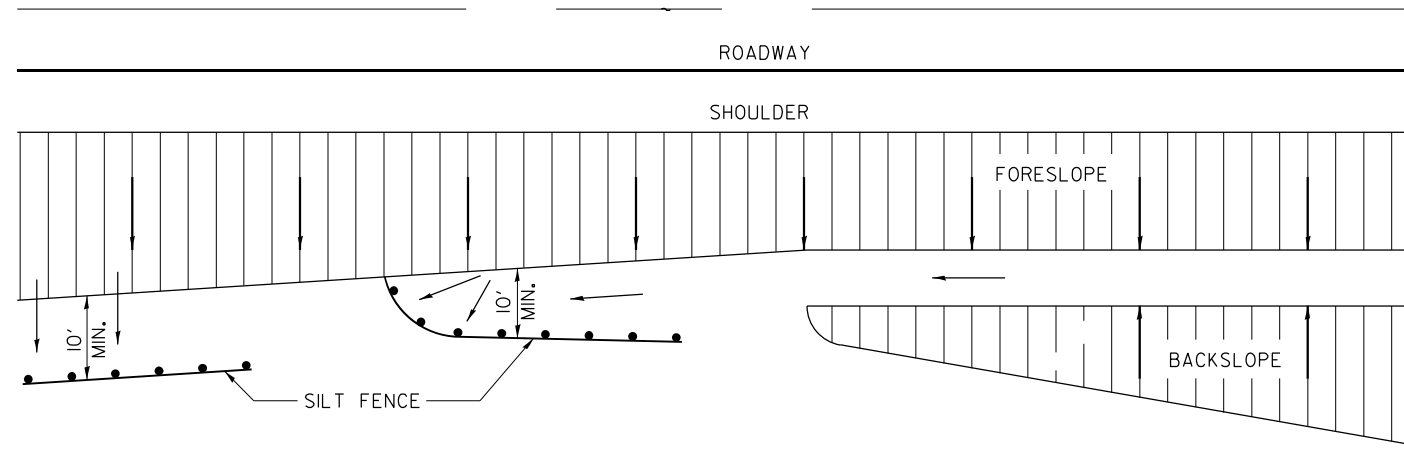

NOTE:  
 WHEN MILLING OPERATIONS PRODUCE A ROUNDED EDGE,  
 THEN A SAW CUT SHALL BE USED TO MANUFACTURE  
 A PERPENDICULAR EDGE AS SHOWN IN THE DETAIL.  
 THE ENGINEER SHALL BE THE SOLE JUDGE  
 CONCERNING THE USE OF THIS DETAIL

**HMA DETAIL AT BUTT JOINTS**

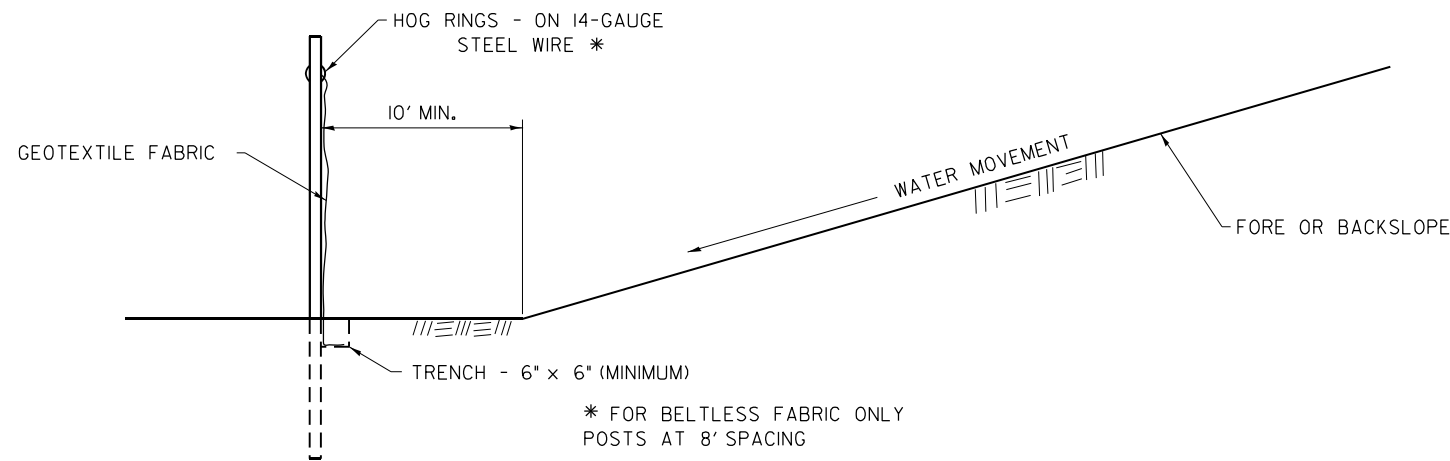

DETAILS OF SILT FENCE

**EROSION CONTROL DETAILS  
 FOR SILT FENCE**

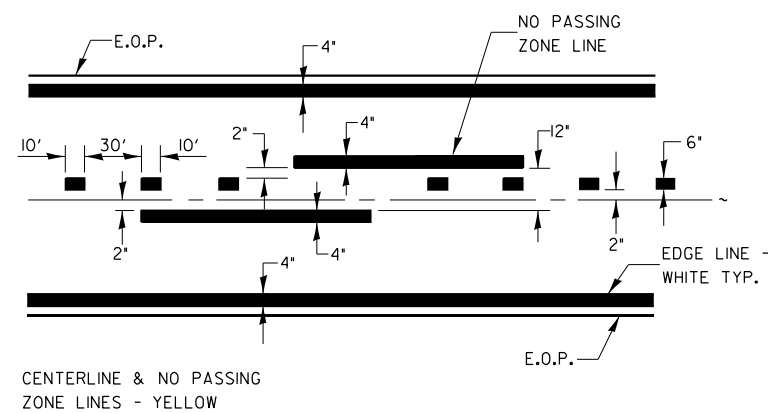

**PAVEMENT MARKING**

FILE NAME =	USER NAME = Troy.Hart	DESIGNED -	REVISED -
pw://idot-pw.bentley.com/PWIDOT/Documents/IDOT Offices/District 3/ORD Projects/D36670/Drawings/CADsheets/D366M70-sht-details		CHECKED -	REVISED -
Default	PLOT DATE = 2/9/2023	DATE -	REVISED -

STATE OF ILLINOIS  
 DEPARTMENT OF TRANSPORTATION

DETAILS			
SCALE:	SHEET	OF	SHEETS
	STA.		TO STA.

F.A.P. RTE.	SECTION	COUNTY	TOTAL SHEETS	SHEET NO.
316	(116 BR)	BUREAU	49	39
CONTRACT NO. 66M70				
ILLINOIS FED. AID PROJECT				

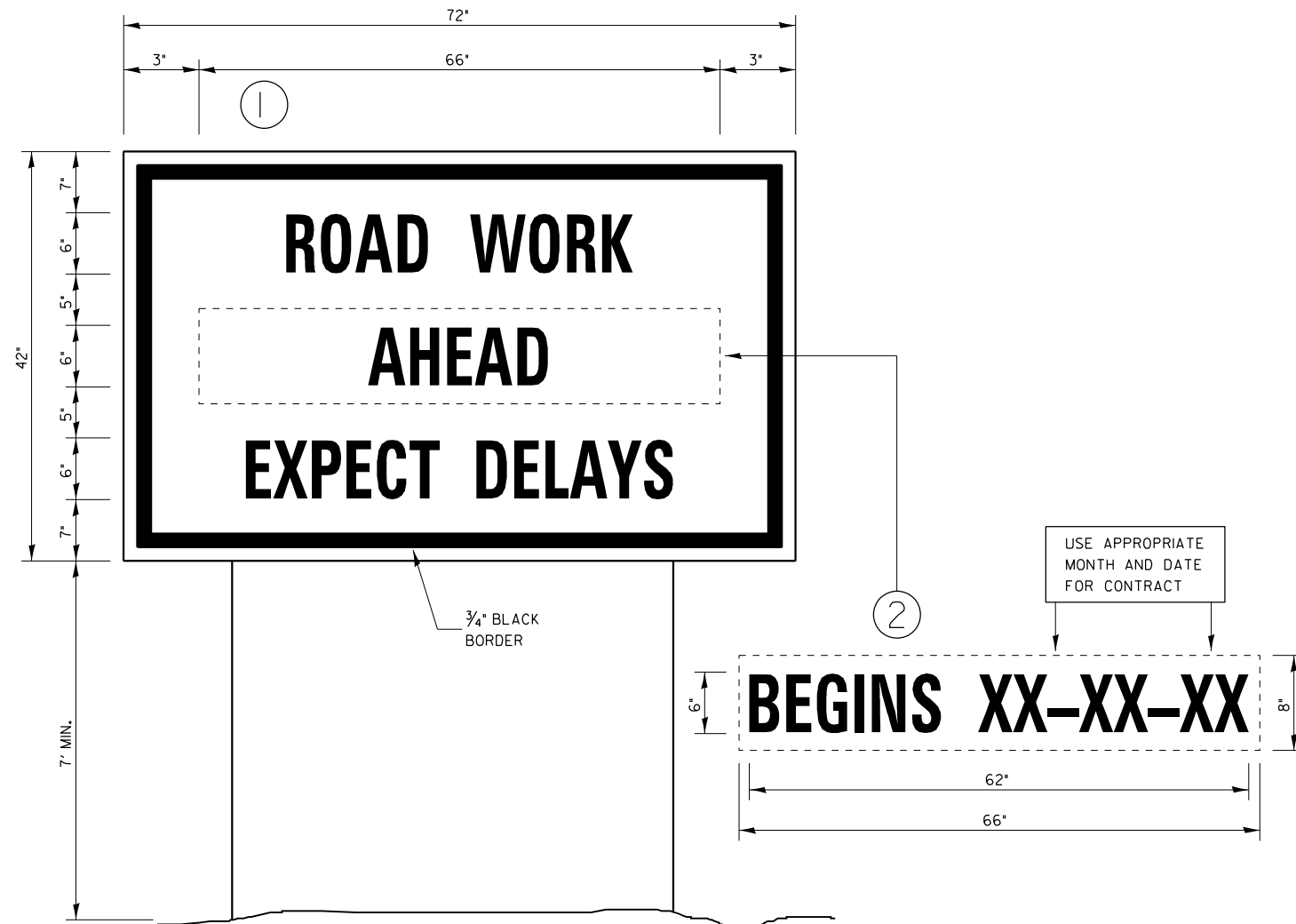

**TEMPORARY INFORMATION SIGNING**

**NOTES:**

1. USE 6" D BLACK LETTERING ON FLOURESENT ORANGE BACKGROUND.
2. ERECT SIGNS AT LOCATIONS IN ADVANCE OF THE "ROAD CONSTRUCTION AHEAD" SIGNS AS DIRECTED BY THE ENGINEER.
3. ERECT SIGN 1 WITH INSTALLED PANEL 2 A MINIMUM OF ONE WEEK PRIOR TO THE START OF THE LANE CLOSURE.
4. REMOVE PANEL 2 ON THAT DATE.
5. SEE SPECIAL PROVISION "TEMPORARY INFORMATION SIGNING" FOR ADDITIONAL INFORMATION.
6. WILL BE PAID FOR PER SO FT AS "TEMPORARY INFORMATION SIGNING". EACH SIGN = 2150 FT AND THE DATE PANEL 2 WILL NOT BE MEASURED SEPARATELY FOR PAYMENT.

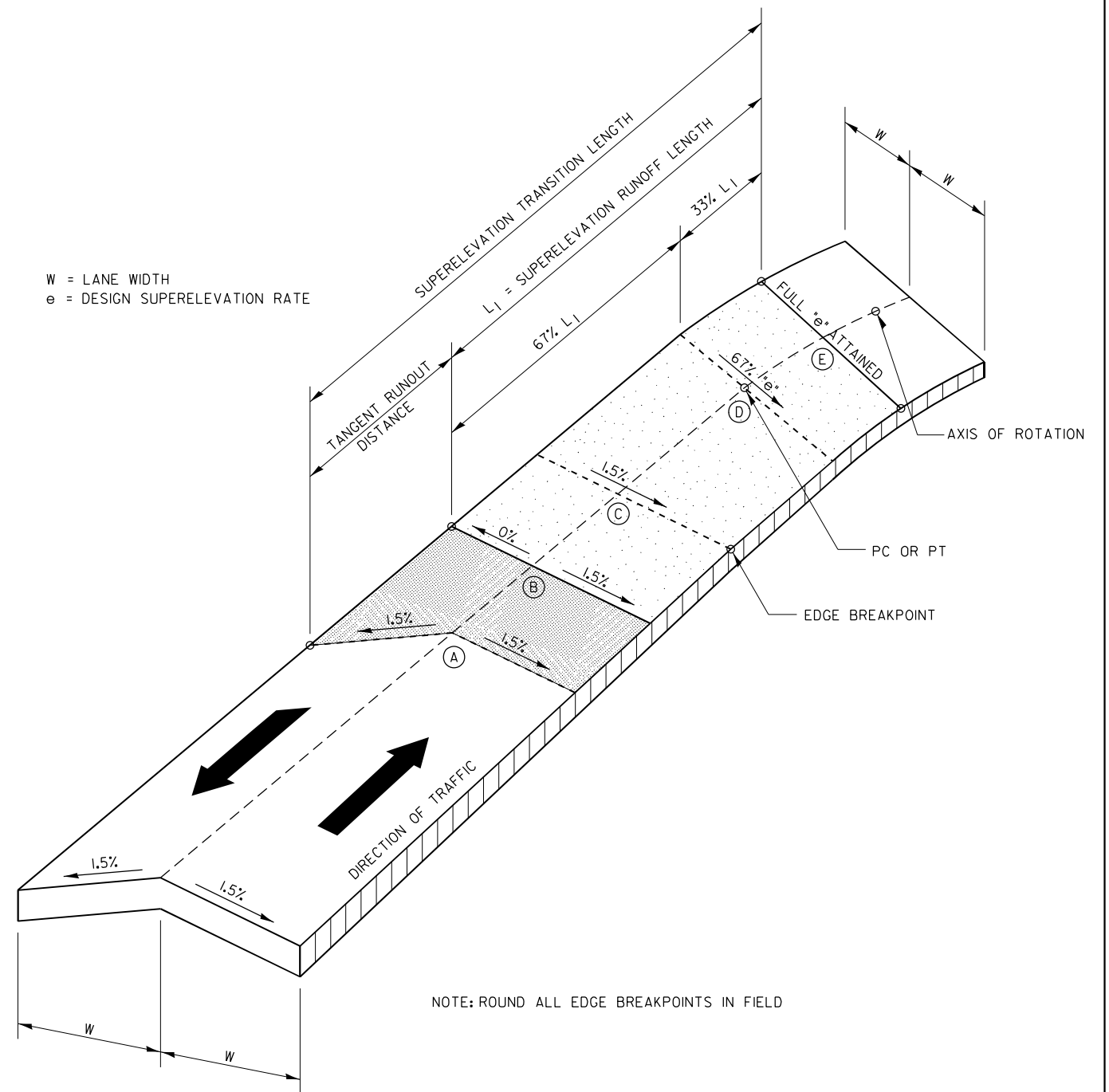

**TRANSITION CURVE TABLE**

CURVE PISTA.	SUPERELEVATION "e"	W	SUPERELEVATION RUNOFF LENGTH	TANGENT RUNOUT DISTANCE	SUPERELEVATION TRANSITION LENGTH
1575+49.05	3.2%	12.0'	82'	38'	120'

**SUPERELEVATION TRANSITION ON TWO-LANE HIGHWAY**



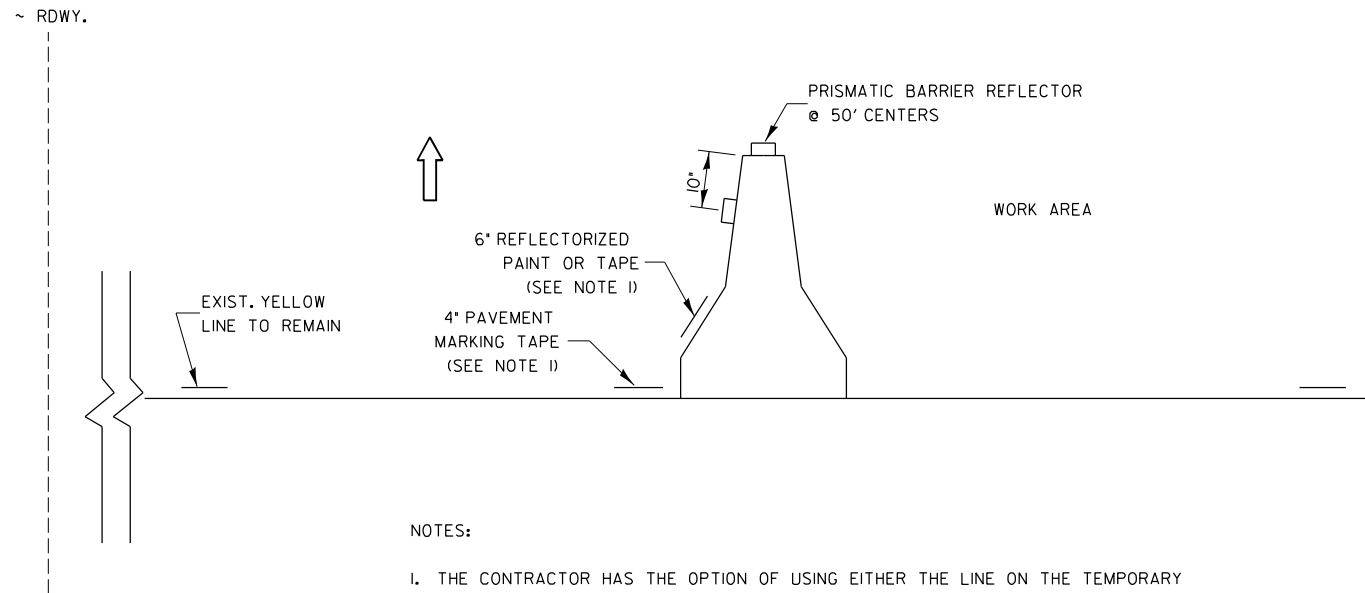

**NOTES:**

1. THE CONTRACTOR HAS THE OPTION OF USING EITHER THE LINE ON THE TEMPORARY CONCRETE BARRIER OR ON THE PAVEMENT.
2. THE COLOR OF THE REFLECTORS AND PAVEMENT/BARRIER MARKING LINE WILL VARY WITH STAGING AND SHALL MATCH THE EXISTING LINE IN THE WORK AREA.
3. THE COST OF THE REFLECTORS AND THE PAVEMENT/BARRIER MARKING LINE IS INCLUDED IN THE COST OF THE TEMPORARY CONCRETE BARRIER.

**TRAFFIC CONTROL DETAIL  
FOR TEMPORARY CONCRETE BARRIER**

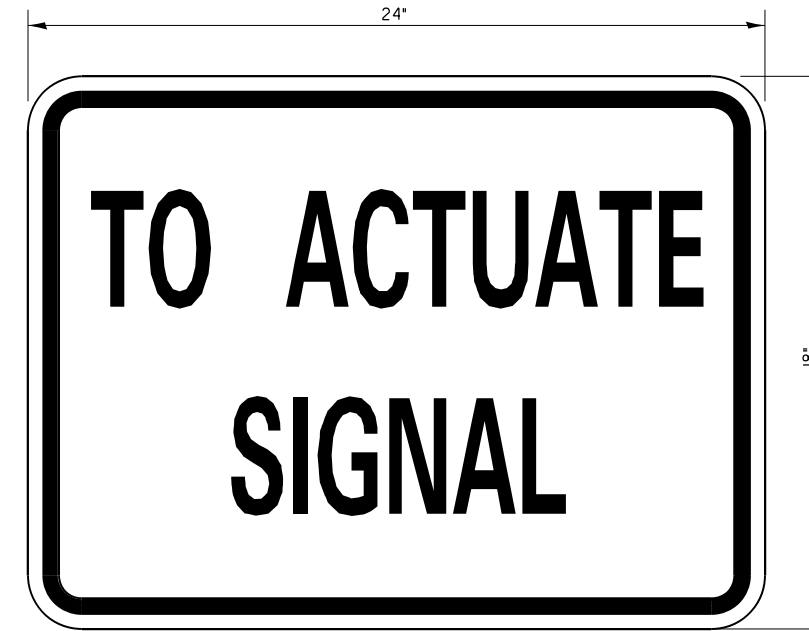

SIZE: 24" x 18"  
 4" CAPITAL LETTERS - BLACK  
 1/2" BORDER - BLACK  
 WHITE REFLECTIVE - TYPE B  
 ENGINEERING GRADE SHEETING

**GENERAL NOTE:**

THIS SIGN SHALL BE INSTALLED AT THE STOP LINE AS DIRECTED BY THE ENGINEER.

**STOP LINE SIGN FOR TEMPORARY SIGNALS**

FILE NAME =	USER NAME = Troy.Hart	DESIGNED -	REVISED -	<b>STATE OF ILLINOIS DEPARTMENT OF TRANSPORTATION</b>	<b>DETAILS</b>				F.A.P. RTE.	SECTION	COUNTY	TOTAL SHEETS	SHEET NO.
pw://idot-pw.bentley.com/PWIDOT/Documents/IDOT Offices/District 3/ORD Projects/D36670/Drawings/CAOsheets/D366M70-sht-detail					DRAWN	REVISED	316	(116 BR)	BUREAU	49	41	<b>CONTRACT NO. 66M70</b>	
Default					CHECKED -	REVISED -					ILLINOIS FED. AID PROJECT		
PLOT SCALE = 100.000' / in.					DATE -	REVISED -							
PLOT DATE = 2/9/2023				DATE -	REVISED -	SCALE: SHEET OF SHEETS STA. TO STA.							

FINAL SURVEY	SURVEYED	BY	DATE
NOTE BOOK	PLOTTED		
AREAS	TEMPLATE		
CHECKED	AREAS		
NO.	CHECKED		

ORIGINAL SURVEY	SURVEYED	BY	DATE
NOTE BOOK	PLOTTED		
AREAS	TEMPLATE		
CHECKED	AREAS		
NO.	CHECKED		

MODEL: IL27 - 1577+00.00 (Sheet)

FILE NAME: p:\mcdrewbentley.com\FWIDOT\Documental\DOT Office\Bentley\3D\RD\Projects\0366\W70\CAD\Drawings\0366\W70 X-Sections

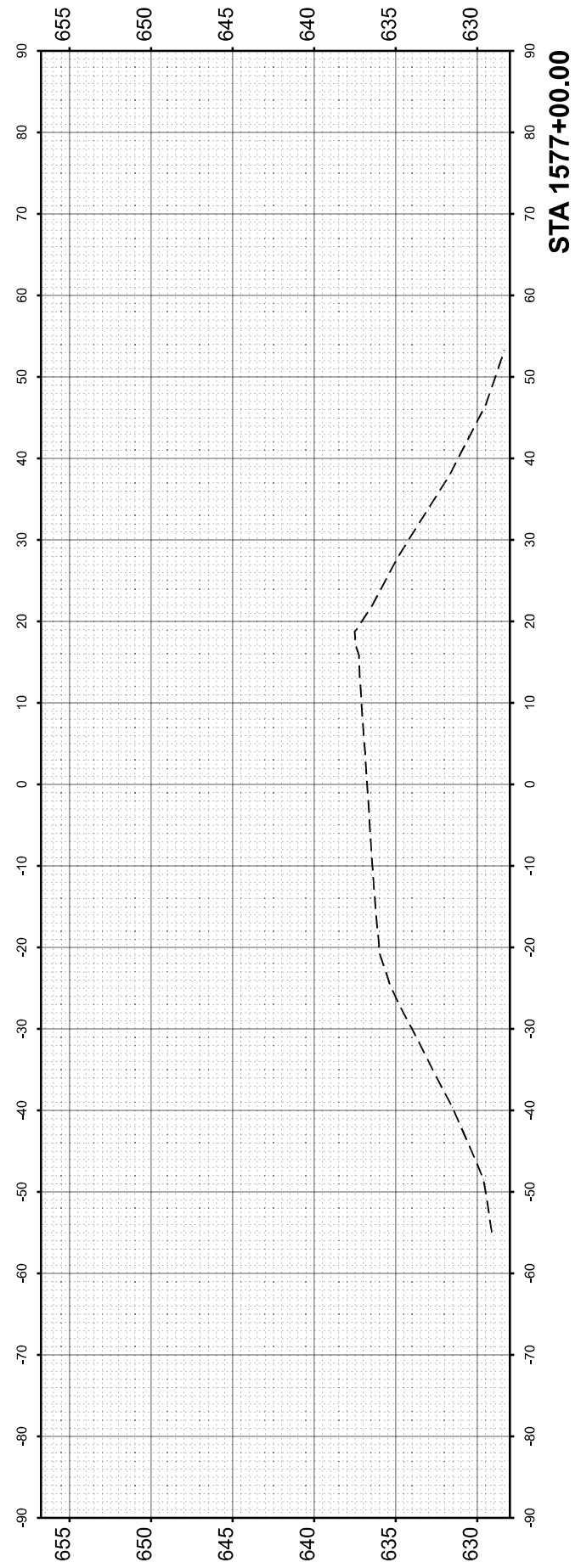
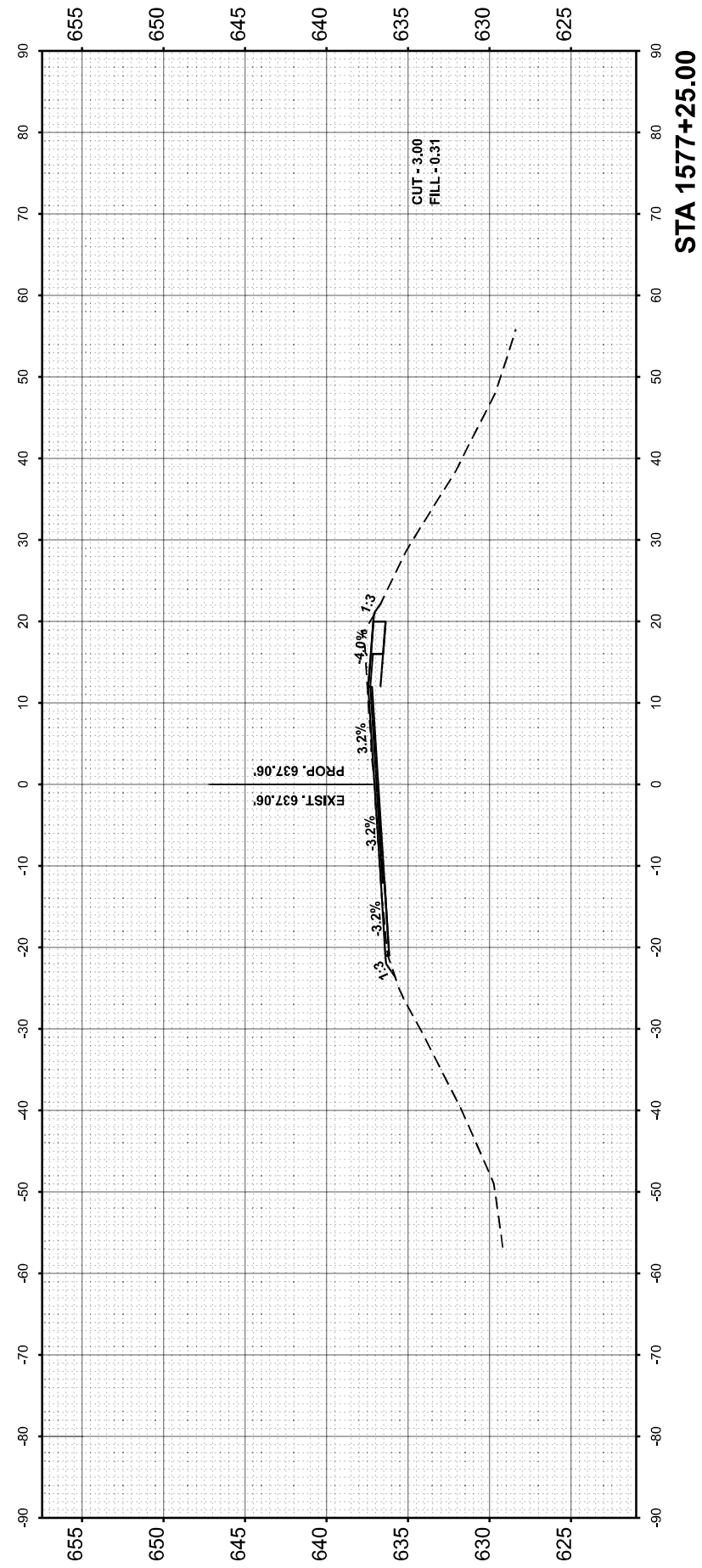
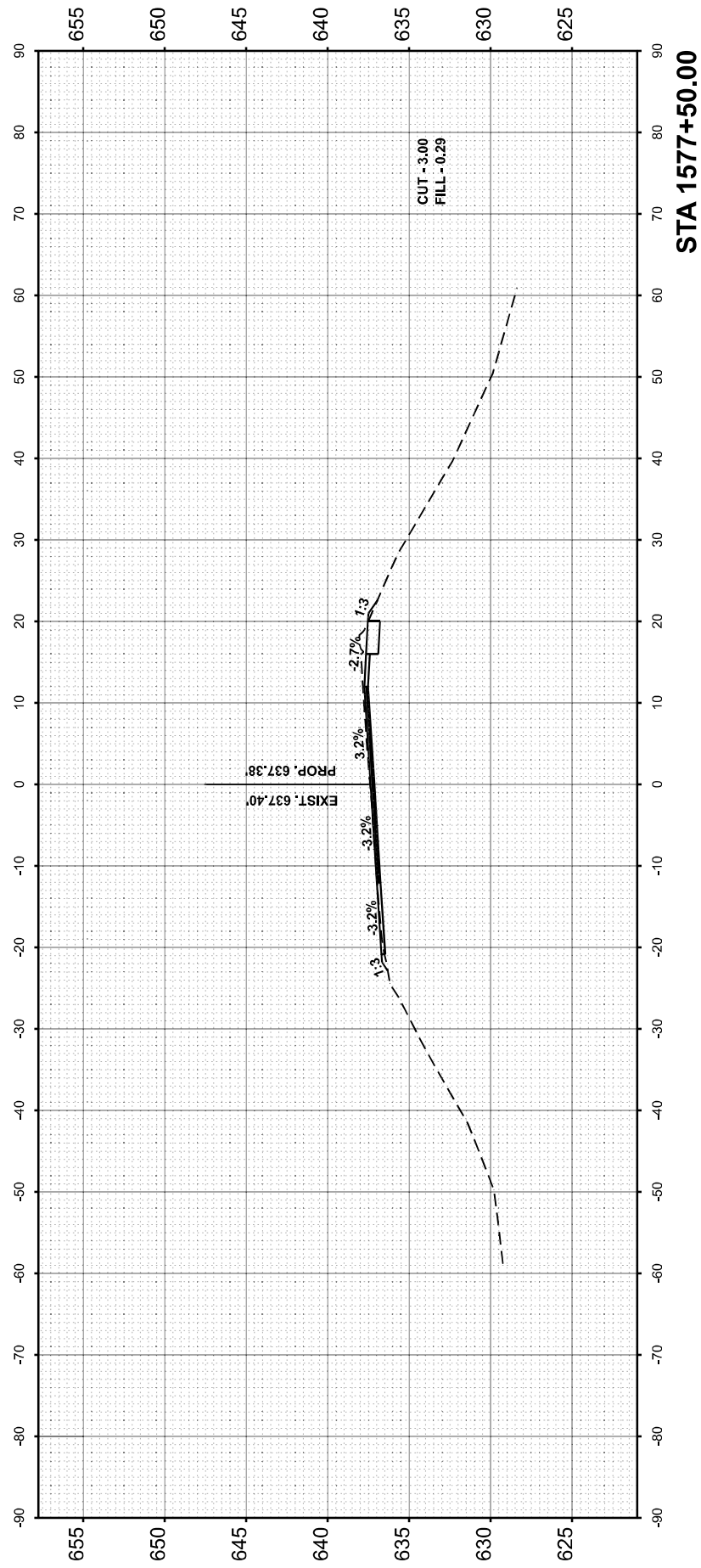

USER NAME =	brandon.oriss	DESIGNED -	REVISED -
PLOT SCALE =	0.16666633' / in.	DRAWN -	REVISED -
PLOT DATE =	2/10/2023	CHECKED -	REVISED -
		DATE -	REVISED -

**STATE OF ILLINOIS  
DEPARTMENT OF TRANSPORTATION**

**CROSS SECTIONS**

SCALE: 1"=10' SHEET OF SHEETS STA. 1577+00 TO STA. 1577+50

F.A.P. RTE.	SECTION	COUNTY	TOTAL SHEETS	SHEET NO.
316	(116 BR)	BUREAU	49	42
ILLINOIS FED. AID PROJECT			CONTRACT NO. 66M70	



FINAL SURVEY NO.	SURVEYED	BY	DATE
	PLOTTED		
	TEMPLATE		
	AREAS CHECKED		

ORIGINAL SURVEY NO.	SURVEYED	BY	DATE
	PLOTTED		
	TEMPLATE		
	AREAS CHECKED		

MODEL: IL27 - 1578+50.00 (Sheet)

FILE NAME: p:\il27\1578+50.00\1578+50.00.dwg

USER NAME =	brandon.oriss
PLOT SCALE =	0.16666633 / in.
PLOT DATE =	2/10/2023

DESIGNED -	_____
DRAWN -	_____
CHECKED -	_____
DATE -	_____

REVISED -	_____
REVISED -	_____
REVISED -	_____
REVISED -	_____

**STATE OF ILLINOIS  
DEPARTMENT OF TRANSPORTATION**

**CROSS SECTIONS**

SCALE: 1"=10'      SHEET      OF      SHEETS      STA. 1578+50      TO STA. 1579+00

F.A.P. RTE.	SECTION	COUNTY	TOTAL SHEETS	SHEET NO.
316	(116 BR)	BUREAU	49	44
CONTRACT NO. 66M70				
ILLINOIS		FED. AID PROJECT		

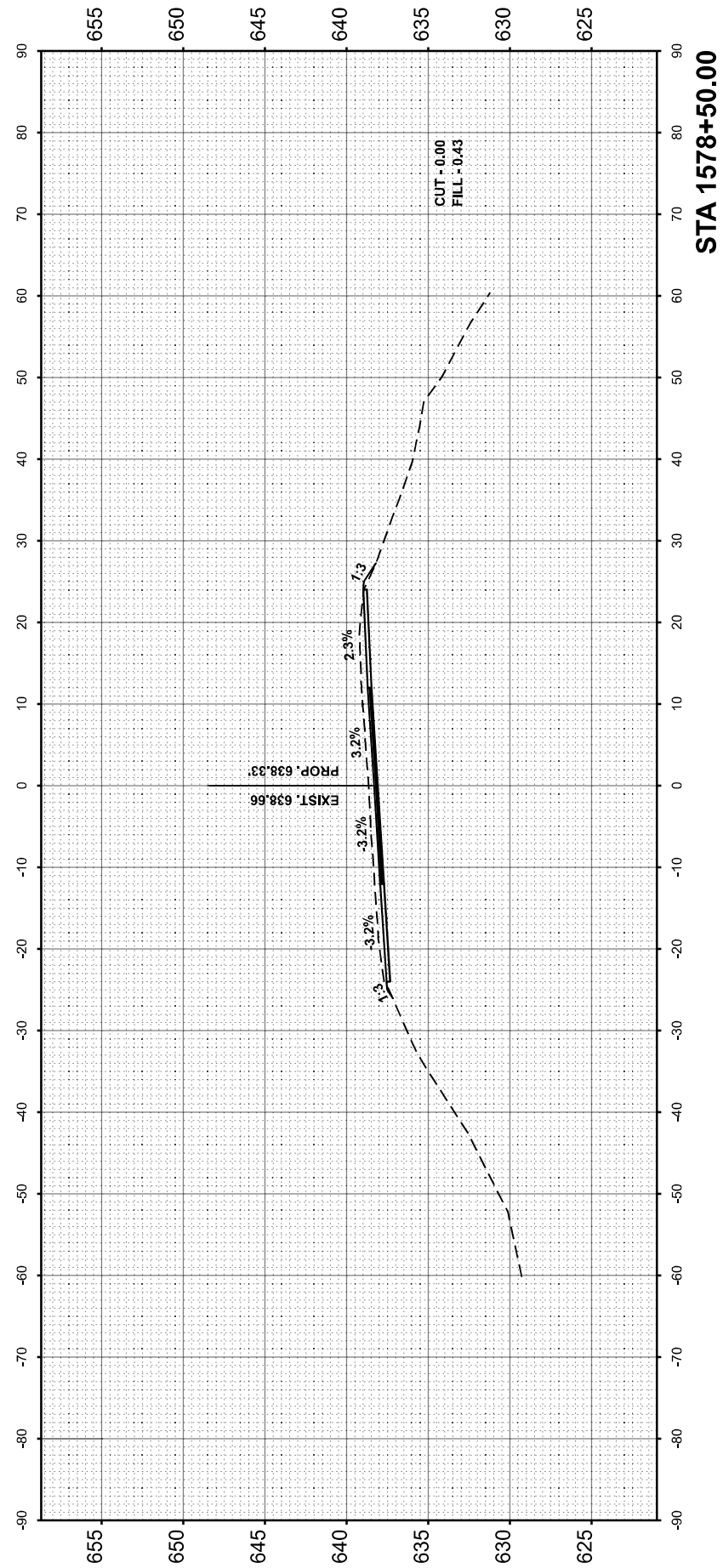
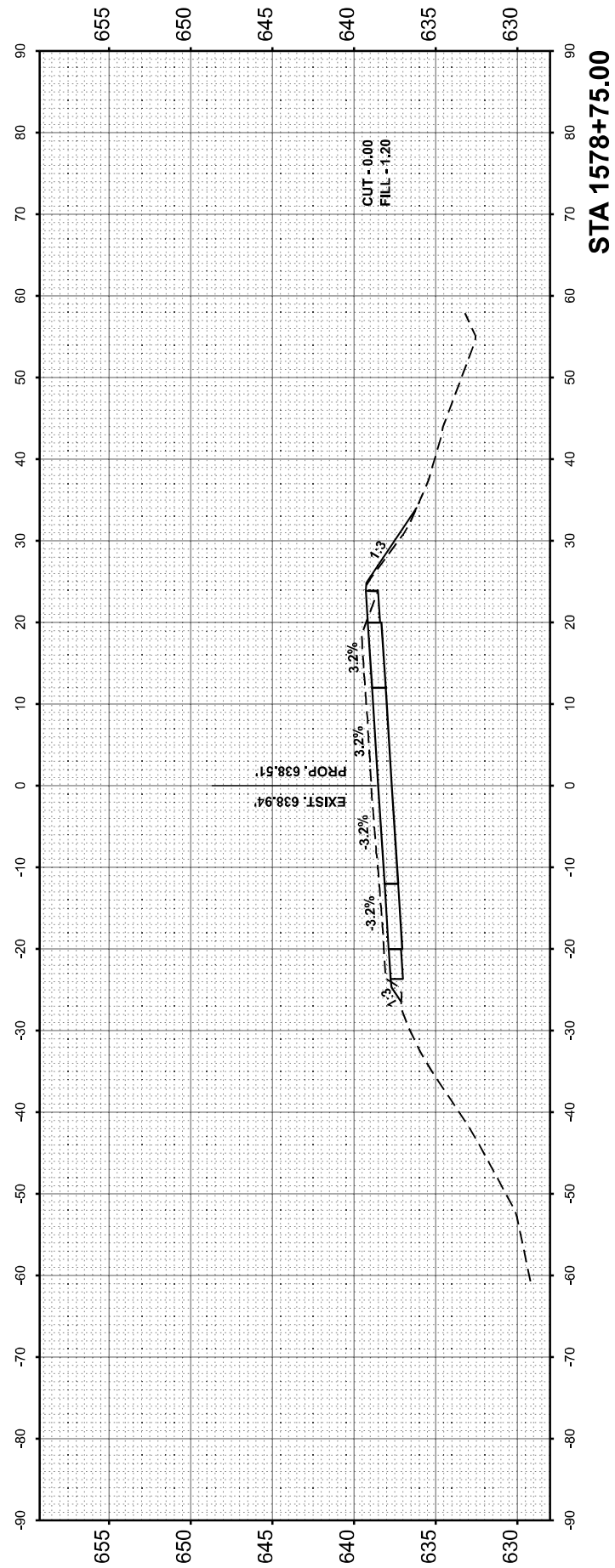
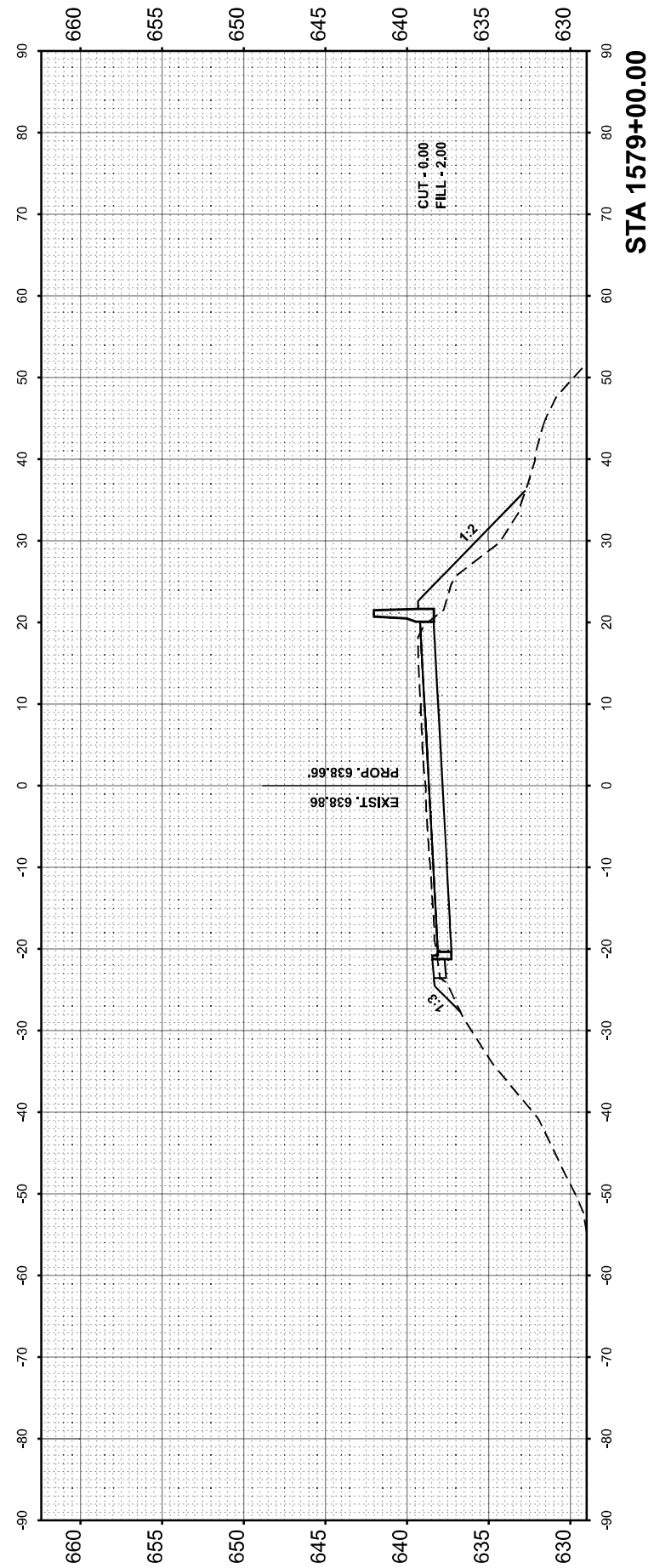

FINAL SURVEY	SUPERVED	BY	DATE
NOTE BOOK	PLOTTED		
AREAS	TEMPLATE		
AS CHECKED	40		

ORIGINAL SURVEY	SUPERVED	BY	DATE
NOTE BOOK	PLOTTED		
AREAS	TEMPLATE		
AS CHECKED	60		

MODEL: IL27 - 1579+25.00 (Sheet)  
 FILE NAME: p:\all\p\work\1579+25\1579+25.dwg

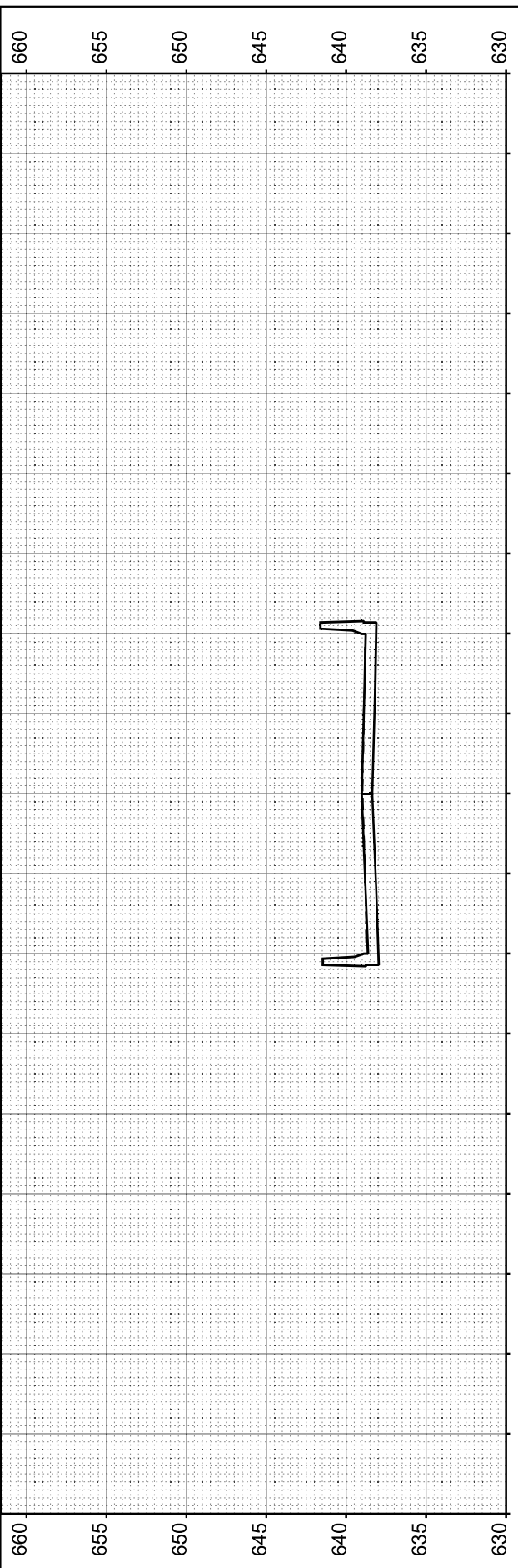

STA 1580+00.00

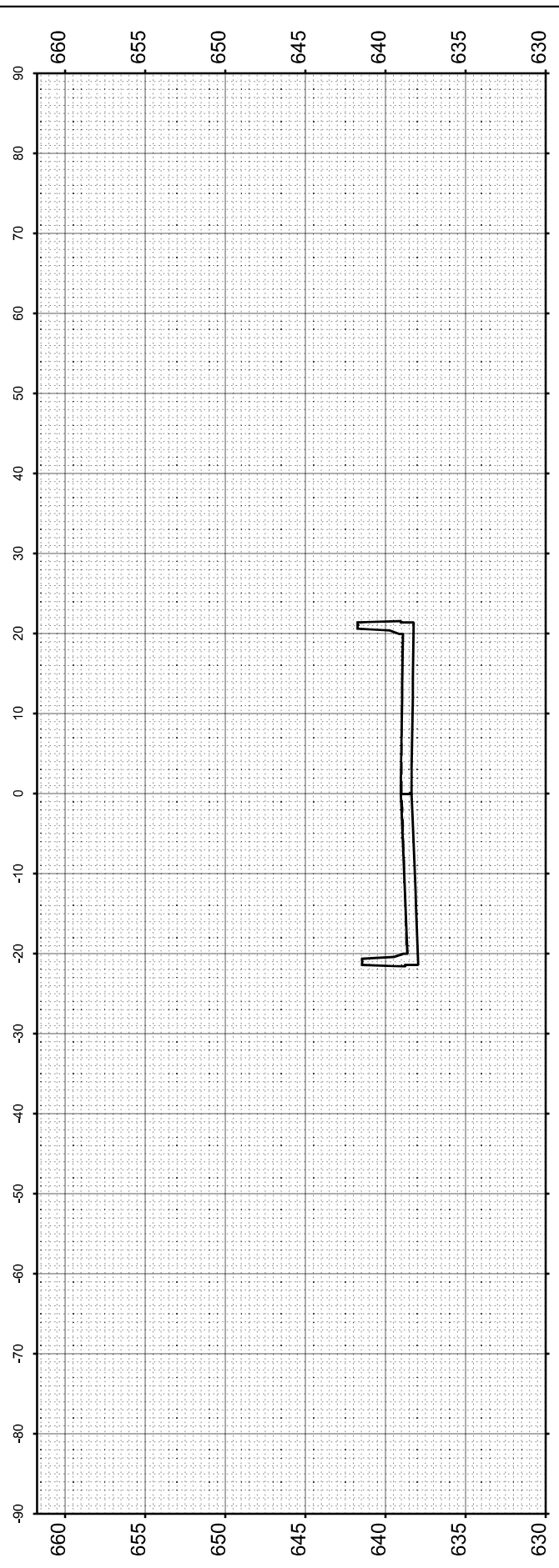

STA 1579+75.00

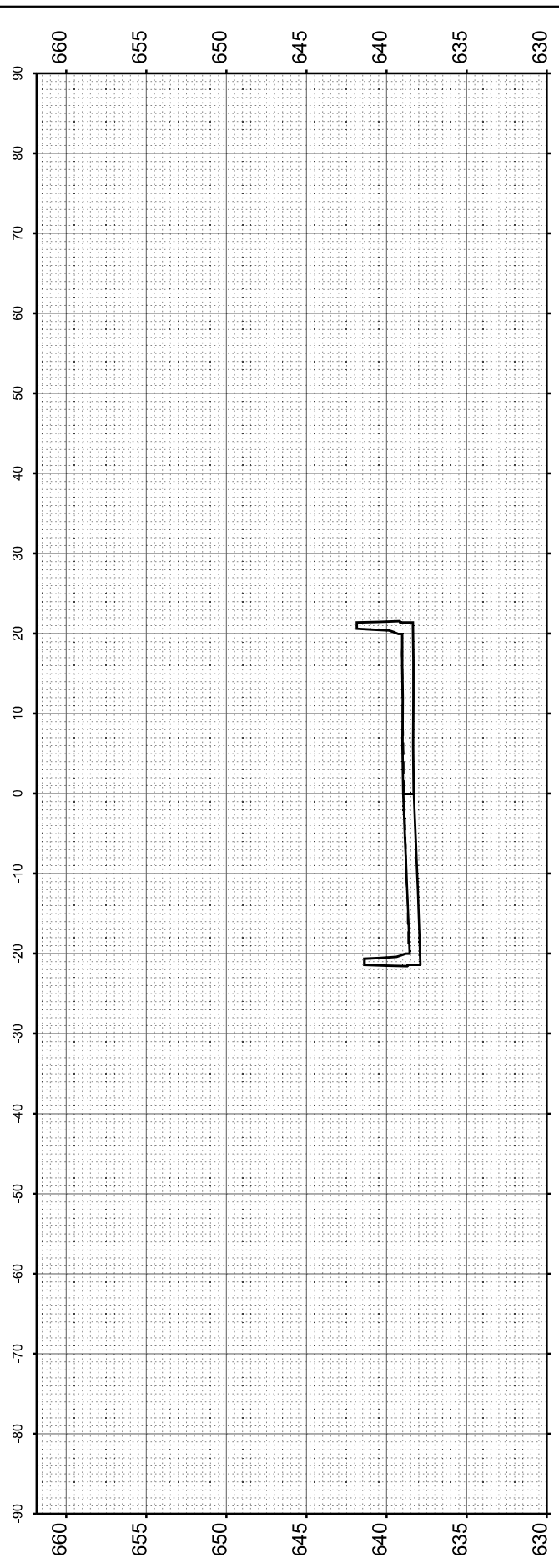

STA 1579+50.00

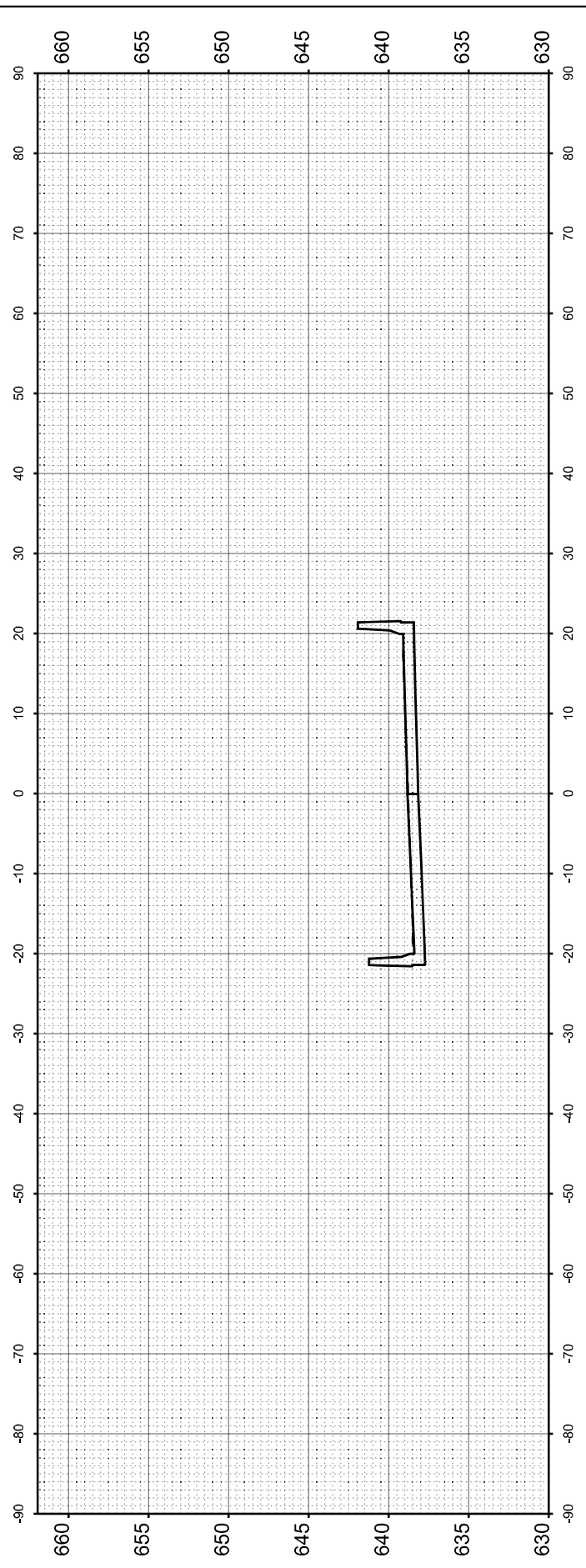

STA 1579+25.00

USER NAME =	brandon.oriss	DESIGNED -	
DRAWN -		REVISED -	
PLOT SCALE =	0.16666633 / in.	CHECKED -	
PLOT DATE =	2/10/2023	REVISIED -	

**STATE OF ILLINOIS  
 DEPARTMENT OF TRANSPORTATION**

**CROSS SECTIONS**

SCALE: 1"=10' SHEET OF SHEETS STA. 1579+25 TO STA. 1580+00

F.A.P. RTE.	SECTION	COUNTY	TOTAL SHEETS	SHEET NO.
316	(116 BR)	BUREAU	49	45
CONTRACT NO. 66M70				
ILLINOIS FED. AID PROJECT				



FINAL SURVEY NO.	20
SURVEYED AREAS	30
PLOTTED AREAS	40
TEMPLATE AREAS	50
DATE	60

ORIGINAL SURVEY NO.	20
SURVEYED AREAS	30
PLOTTED AREAS	40
TEMPLATE AREAS	50
DATE	60

MODEL: IL27 - 1581+25.00 (Sheet)  
 FILE NAME: p:\all\sp\cm\by\cm\66M70\Drawings\66M70\CAO\Drawings\66M70\Sections\66M70\Sections

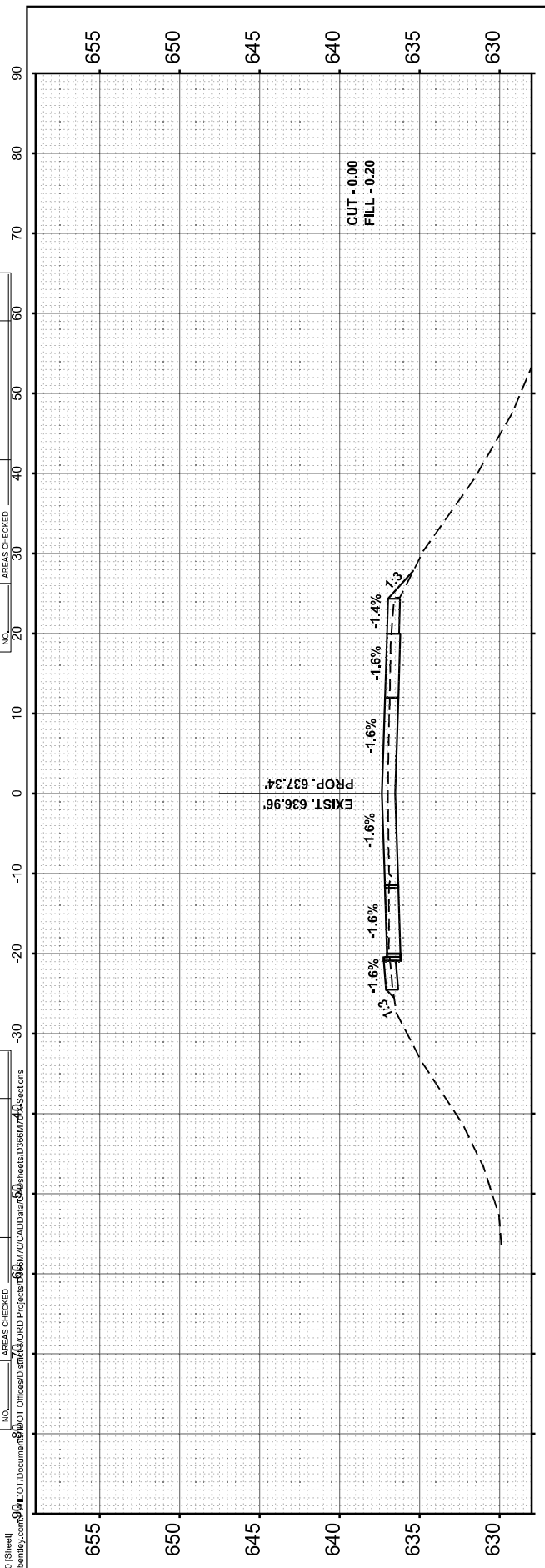

**STA 1582+00.00**

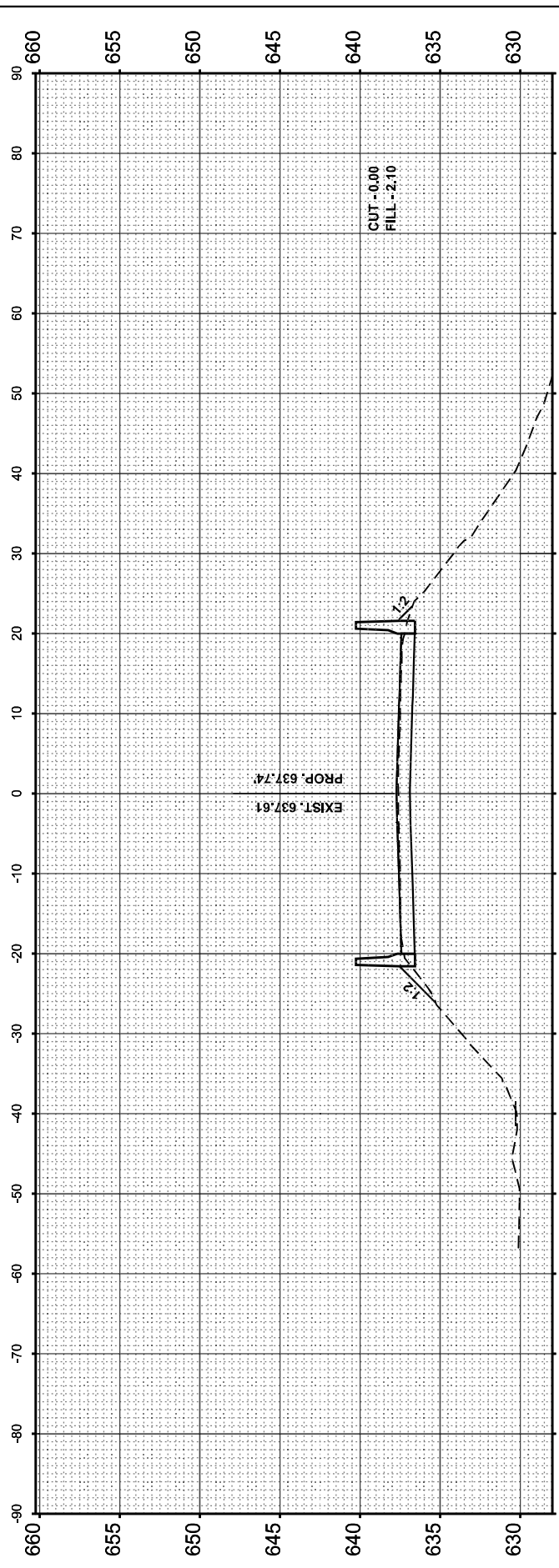

**STA 1581+75.00**

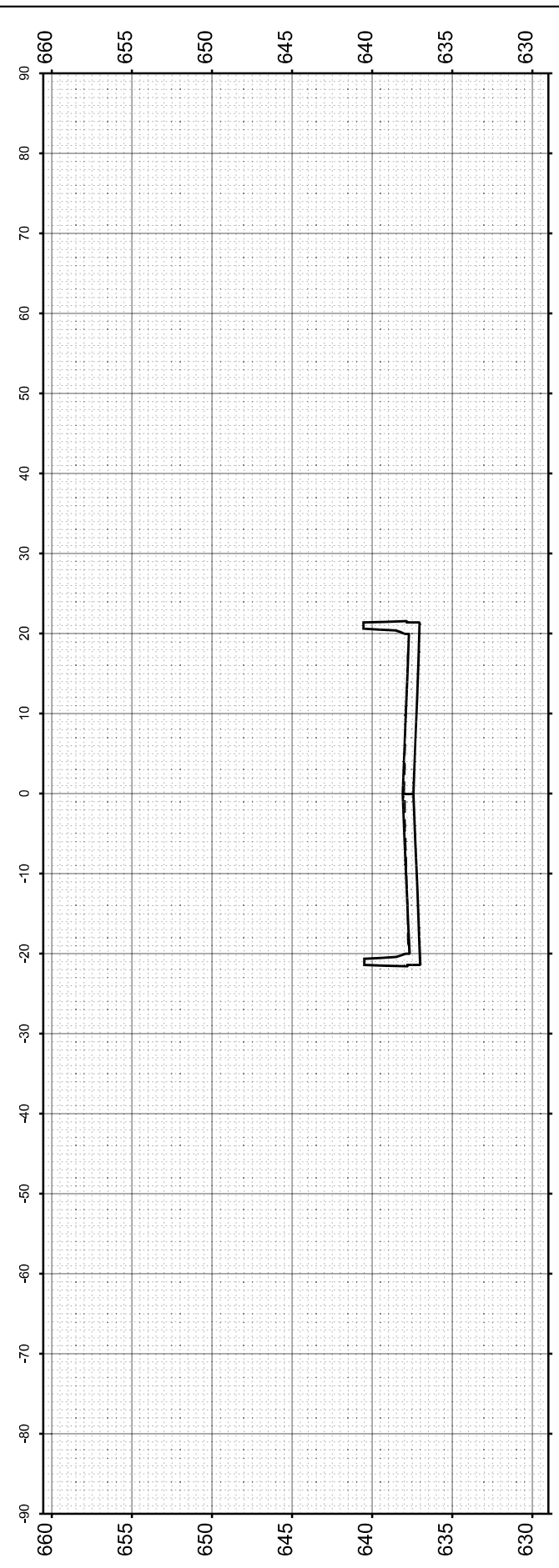

**STA 1581+50.00**

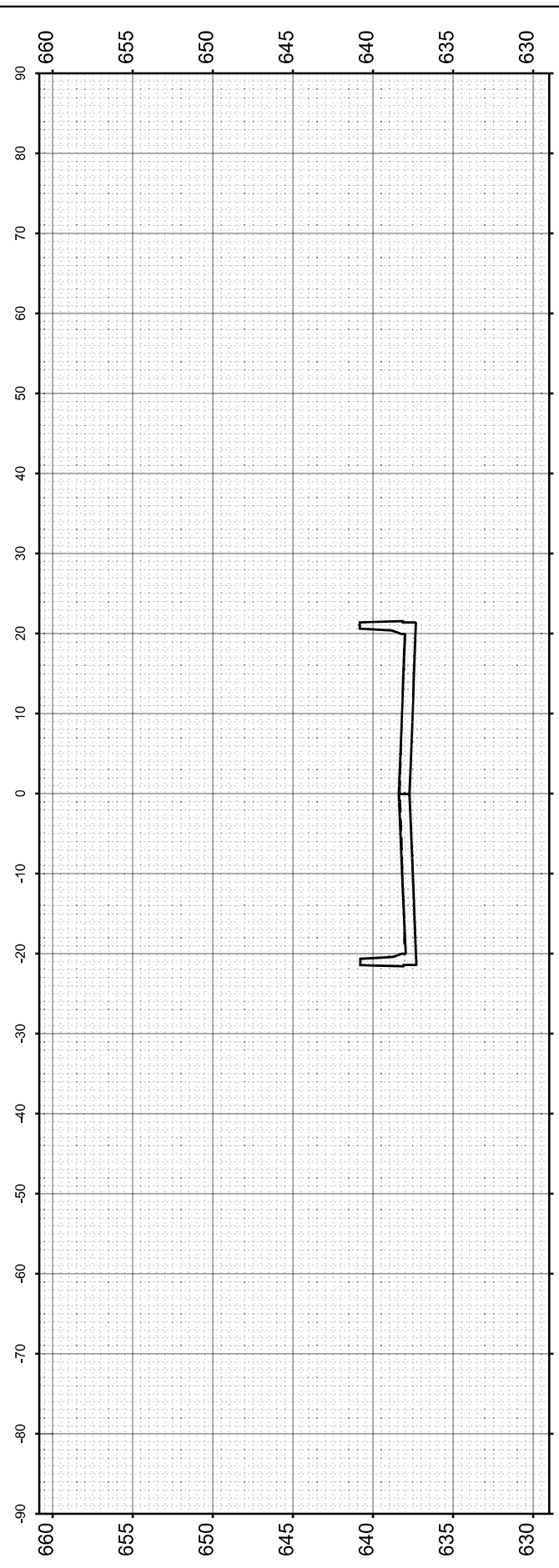

**STA 1581+25.00**

USER NAME = brandon.oriss	DESIGNED -	REVISED -
PLOT SCALE = 0.16666633 / in.	DRAWN -	REVISED -
PLOT DATE = 2/10/2023	CHECKED -	REVISED -
	DATE -	REVISED -

**STATE OF ILLINOIS  
 DEPARTMENT OF TRANSPORTATION**

**CROSS SECTIONS**

SCALE: 1"=10'      SHEET      OF      SHEETS      STA. 1581+25      TO STA. 1582+00

F.A.P. RTE.	SECTION	COUNTY	TOTAL SHEETS	SHEET NO.
316	(116 BR)	BUREAU	49	47
CONTRACT NO. 66M70				
ILLINOIS   FED. AID PROJECT				

FINAL SURVEY NO.	SURVEYED	BY	DATE
	PLOTTED		
	TEMPLATE		
	AREAS CHECKED		

ORIGINAL SURVEY NO.	SURVEYED	BY	DATE
	PLOTTED		
	TEMPLATE		
	AREAS CHECKED		

MODEL: IL27 - 1582+25.00 (Sheet)

FILE NAME: p:\il27\1582+25.00\1582+25.00.dwg

USER NAME =	brandon.oriss
PLOT SCALE =	0.16666633 / in.
PLOT DATE =	2/10/2023

DESIGNED -	
DRAWN -	
CHECKED -	
DATE -	

REVISED -	
REVISED -	
REVISED -	
REVISED -	

**STATE OF ILLINOIS  
DEPARTMENT OF TRANSPORTATION**

**CROSS SECTIONS**

SCALE: 1"=10'      SHEET      OF      SHEETS      STA. 1582+25      TO STA. 1582+75

F.A.P. RTE.	SECTION	COUNTY	TOTAL SHEETS	SHEET NO.
316	(116 BR)	BUREAU	49	48
CONTRACT NO. 66M70				
ILLINOIS		FED. AID PROJECT		

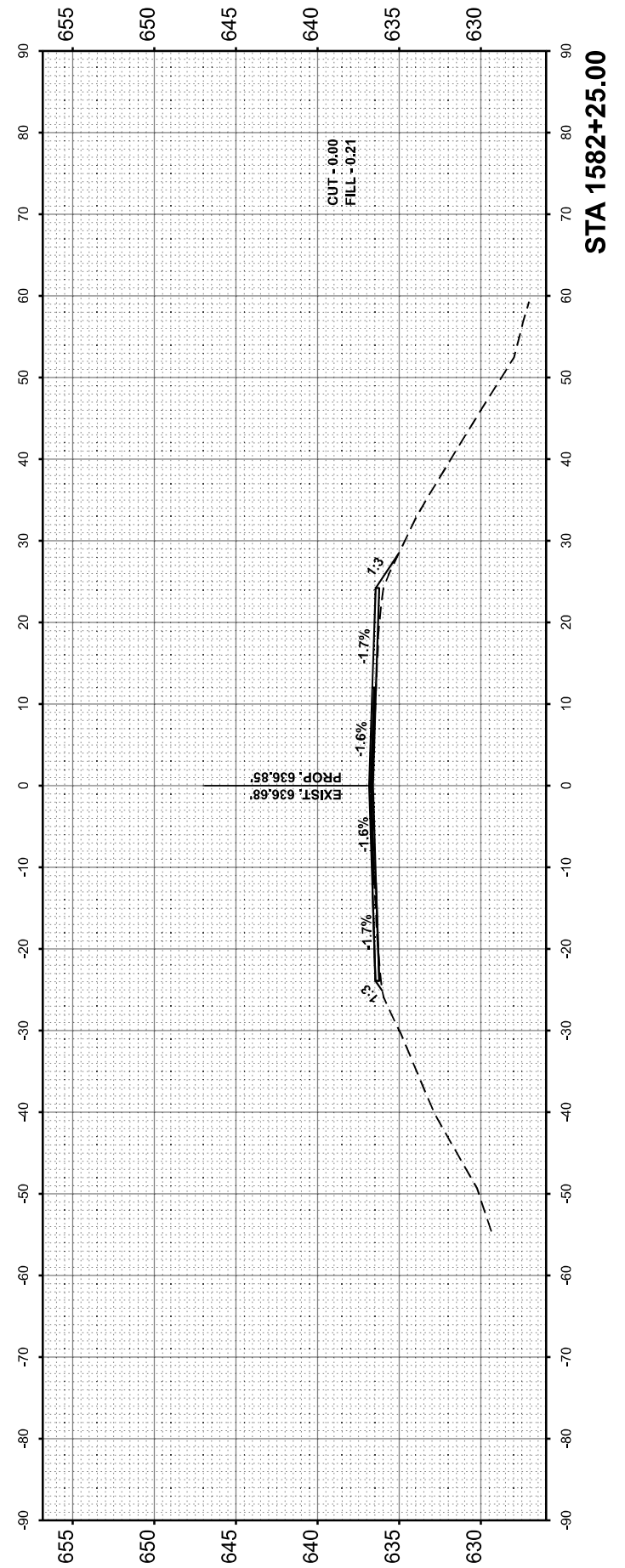
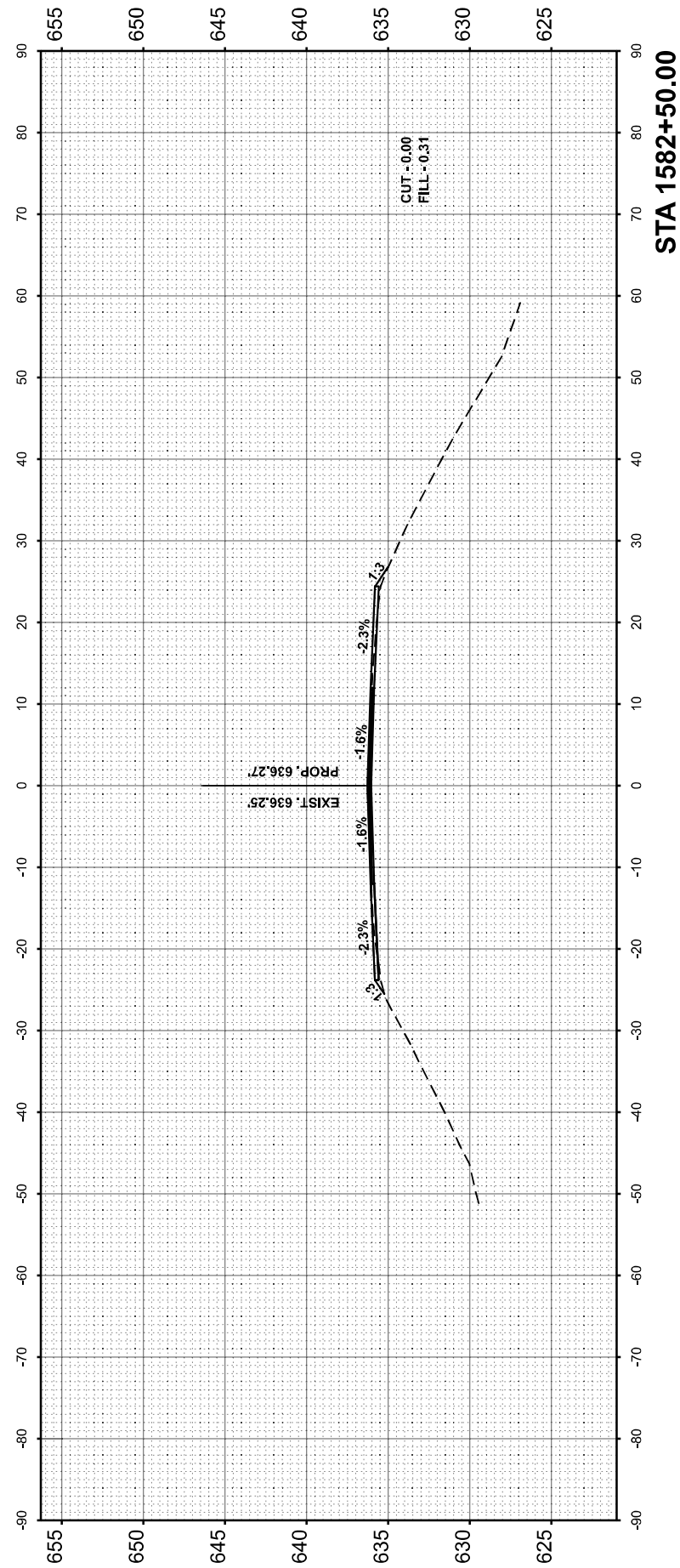
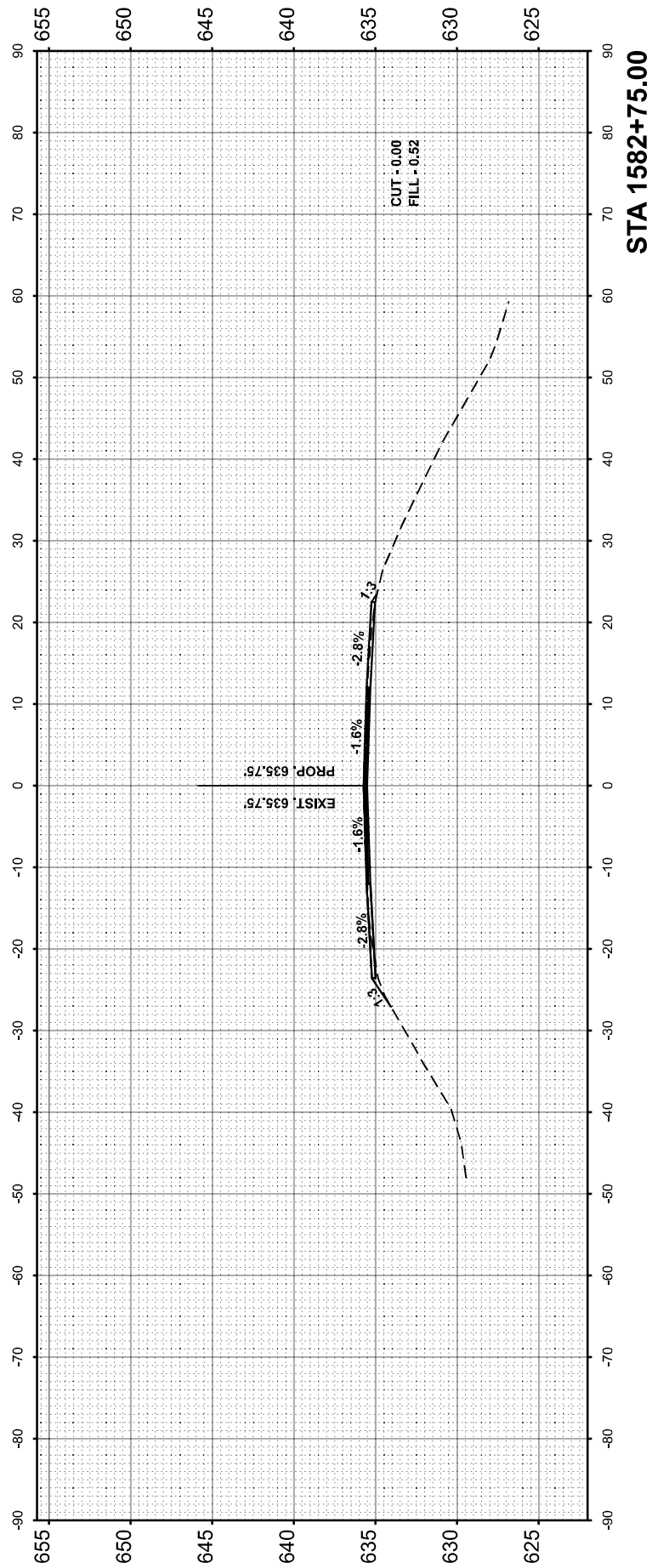



FINAL SURVEY NO.	SURVEYED BY	DATE
NOTE BOOK NO.	PLOTTED BY	
	TEMPLATE	
	AREAS CHECKED	

ORIGINAL SURVEY NO.	SURVEYED BY	DATE
NOTE BOOK NO.	PLOTTED BY	
	TEMPLATE	
	AREAS CHECKED	

MODEL: IL27 - 1583+00.00 (Sheet)

FILE NAME: p:\il27\1583+00.00\1583+00.00.dwg

USER NAME =	brandon.oriss
PLOT SCALE =	0.16666633 / in.
PLOT DATE =	2/10/2023

DESIGNED -	
DRAWN -	
CHECKED -	
DATE -	

REVISED -	
REVISED -	
REVISED -	
REVISED -	

**STATE OF ILLINOIS  
DEPARTMENT OF TRANSPORTATION**

**CROSS SECTIONS**

SCALE: 1"=10'      SHEET      OF      SHEETS      STA. 1583+00      TO STA. 1583+50

F.A.P. RTE.	SECTION	COUNTY	TOTAL SHEETS	SHEET NO.
316	(116 BR)	BUREAU	49	49
CONTRACT NO. 66M70				
ILLINOIS FED. AID PROJECT				

